

### Intellimod™ Module Dual-In-Line Intelligent Power Module 20 Amperes/600 Volts

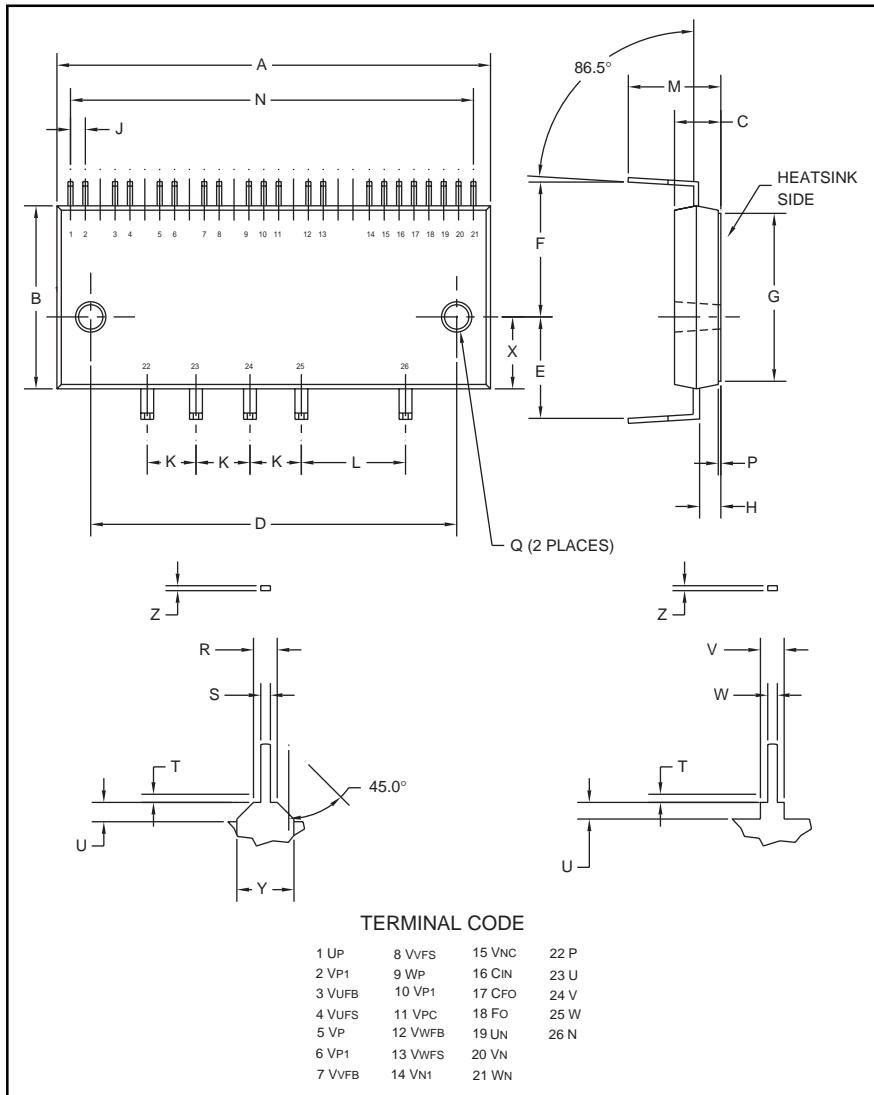

Outline Drawing and Circuit Diagram

Dimensions	Inches	Millimeters
A	3.07±0.02	79.0±0.5
B	1.22±0.02	31.0±0.5
C	0.32±0.02	8.0±0.5
D	2.64±0.01	67.0±0.3
E	0.53±0.01 Dia.	13.4±0.2 Dia.
F	0.84±0.02	21.4±0.5
G	1.10±0.02	28.0±0.5
H	0.15±0.01	3.8±0.2
J	0.11±0.01	2.8±0.3
K	0.39±0.01	10.0±0.3
L	0.79±0.01	20.0±0.3
M	0.50±0.04	12.8±1.0

Dimensions	Inches	Millimeters
N	2.98	75.6
P	0.02±0.01	0.5±0.2
Q	0.18±0.01 Dia.	4.5±0.2 Dia.
R	0.08±0.02	1.9±0.05
S	0.04±0.01	1.0±0.2
T	0.02 Max.	0.5 Max.
U	0.02±0.02	0.6±0.5
V	0.07 Max.	1.75 Max.
W	0.03±0.01	0.8±0.2
X	0.45±0.02	11.5±0.5
Y	0.13 Max.	3.25 Max.
Z	0.03	0.7

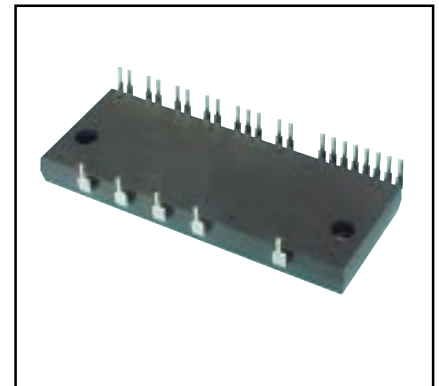

#### Description:

DIP and mini-DIP IPMs are intelligent power modules that integrate power devices, drivers, and protection circuitry in an ultra compact dual-in-line transfer-mold package for use in driving small three phase motors. Use of 4th generation IGBTs, DIP packaging, and application specific HVICs allow the designer to reduce inverter size and overall design time.

#### Features:

- Compact Packages
- Single Power Supply
- Integrated HVICs
- Direct Connection to CPU
- Optimized for 5kHz Operation

#### Applications:

- Washing Machines
- Refrigerators
- Air Conditioners
- Small Servo Motors
- Small Motor Control

#### Ordering Information:

PS21245-E is a 600V, 20 Ampere DIP Intelligent Power Module.



Powerex, Inc., 200 Hillis Street, Youngwood, Pennsylvania 15697-1800 (724) 925-7272

**PS21245-E**  
**Intellimod™ Module**  
**Dual-In-Line Intelligent Power Module**  
 20 Amperes/600 Volts

### Absolute Maximum Ratings, $T_j = 25^\circ\text{C}$ unless otherwise specified

Characteristics	Symbol	PS21245-E	Units
Power Device Junction Temperature*	$T_j$	-20 to 150	$^\circ\text{C}$
Storage Temperature	$T_{\text{stg}}$	-40 to 125	$^\circ\text{C}$
Case Operating Temperature (See $T_C$ Measure Point Illustration)	$T_C$	-20 to 100	$^\circ\text{C}$
Mounting Torque, M4 Mounting Screws	—	13	in-lb
Module Weight (Typical)	—	54	Grams
Heatsink Flatness	—	-50 to 100	$\mu\text{m}$
Self-protection Supply Voltage Limit (Short Circuit Protection Capability)**	$V_{\text{CC(prot.)}}$	400	Volts
Isolation Voltage, AC 1 minute, 60Hz Sinusoidal, Connection Pins to Heatsink Plate	$V_{\text{ISO}}$	1500	Volts

\*The maximum junction temperature rating of the power chips integrated within the DIP-IPM is  $150^\circ\text{C}$  ( $@T_C \leq 100^\circ\text{C}$ ). However, to ensure safe operation of the DIP-IPM, the average junction temperature should be limited to  $T_{j(\text{avg})} \leq 125^\circ\text{C}$  ( $@T_C \leq 100^\circ\text{C}$ ).

\*\* $V_D = V_{\text{DB}} = 13.5 \sim 16.5\text{V}$ , Inverter Part,  $T_j = 125^\circ\text{C}$ , Non-repetitive, Less than  $2\mu\text{s}$

### IGBT Inverter Sector

Collector-Emitter Voltage	$V_{\text{CES}}$	600	Volts
Collector Current, $\pm$ ( $T_C = 25^\circ\text{C}$ )	$I_C$	20	Amperes
Peak Collector Current, $\pm$ ( $T_C = 25^\circ\text{C}$ , Instantaneous Value (Pulse))	$I_{\text{CP}}$	40	Amperes
Supply Voltage (Applied between P - N)	$V_{\text{CC}}$	450	Volts
Supply Voltage, Surge (Applied between P - N)	$V_{\text{CC(surge)}}$	500	Volts
Collector Dissipation ( $T_C = 25^\circ\text{C}$ , per 1 Chip)	$P_C$	56	Watts

### Control Sector

Supply Voltage (Applied between $V_{\text{P1}}-V_{\text{PC}}$ , $V_{\text{N1}}-V_{\text{NC}}$ )	$V_D$	20	Volts
Supply Voltage (Applied between $V_{\text{UFB}}-V_{\text{UFS}}$ , $V_{\text{VFB}}-V_{\text{VFS}}$ , $V_{\text{WFB}}-V_{\text{WFS}}$ )	$V_{\text{DB}}$	20	Volts
Input Voltage (Applied between $U_P$ , $V_P$ , $W_P-V_{\text{PC}}$ , $U_N$ , $V_N$ , $W_N-V_{\text{NC}}$ )	$V_{\text{CIN}}$	-0.5 ~ 5.5	Volts
Fault Output Supply Voltage (Applied between $F_O-V_{\text{NC}}$ )	$V_{\text{FO}}$	-0.5 ~ $V_D+0.5$	Volts
Fault Output Current (Sink Current at $F_O$ Terminal)	$I_{\text{FO}}$	15	mA
Current Sensing Input Voltage (Applied between $C_{\text{IN}}-V_{\text{NC}}$ )	$V_{\text{SC}}$	-0.5 ~ $V_D+0.5$	Volts



Powerex, Inc., 200 Hillis Street, Youngwood, Pennsylvania 15697-1800 (724) 925-7272

**PS21245-E**  
**Intellimod™ Module**  
**Dual-In-Line Intelligent Power Module**  
 20 Amperes/600 Volts

**Electrical and Mechanical Characteristics,  $T_j = 25^\circ\text{C}$  unless otherwise specified**

Characteristics	Symbol	Test Conditions	Min.	Typ.	Max.	Units
<b>IGBT Inverter Sector</b>						
Collector Cutoff Current	$I_{CES}$	$V_{CE} = V_{CES}, T_j = 25^\circ\text{C}$	—	—	1.0	mA
		$V_{CE} = V_{CES}, T_j = 125^\circ\text{C}$	—	—	10	mA
Diode Forward Voltage	$V_{EC}$	$T_j = 25^\circ\text{C}, -I_C = 20\text{A}, V_{CIN} = 5\text{V}$	—	2.2	3.0	Volts
Collector-Emitter Saturation Voltage	$V_{CE(sat)}$	$I_C = 20\text{A}, T_j = 25^\circ\text{C}, V_D = V_{DB} = 15\text{V}, V_{CIN} = 0\text{V}$	—	1.55	2.15	Volts
		$I_C = 20\text{A}, T_j = 125^\circ\text{C}, V_D = V_{DB} = 15\text{V}, V_{CIN} = 0\text{V}$	—	1.65	2.25	Volts
Inductive Load Switching Times	$t_{on}$	$V_{CC} = 300\text{V}, V_D = 15\text{V},$	0.1	0.8	1.3	$\mu\text{S}$
	$t_{rr}$	$I_C = 20\text{A}, T_j = 125^\circ\text{C}, V_{CIN} = 5\text{V(off), } 0\text{V(on),}$	—	0.1	—	$\mu\text{S}$
	$t_{C(on)}$	Inductive Load (Upper-Lower Arm),	—	0.5	0.9	$\mu\text{S}$
	$t_{off}$	Note: $t_{on}, t_{off}$ includes delay time of	—	1.6	2.7	$\mu\text{S}$
	$t_{C(off)}$	the internal control circuit.	—	1.0	1.9	$\mu\text{S}$

$T_C$  Measure Point

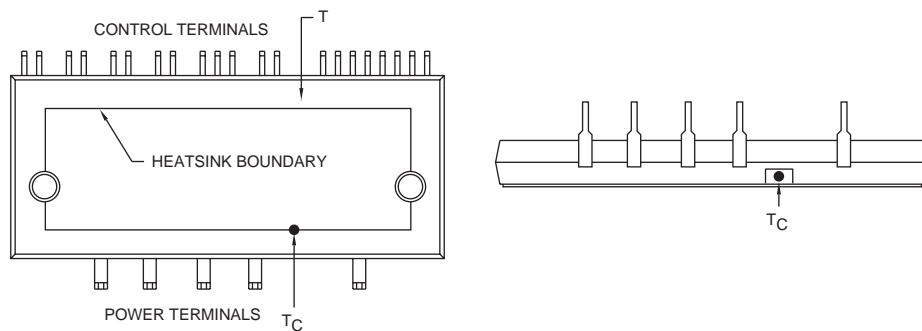



Powerex, Inc., 200 Hillis Street, Youngwood, Pennsylvania 15697-1800 (724) 925-7272

**PS21245-E**  
**Intellimod™ Module**  
**Dual-In-Line Intelligent Power Module**  
 20 Amperes/600 Volts

**Electrical and Mechanical Characteristics,  $T_j = 25^\circ\text{C}$  unless otherwise specified**

Characteristics	Symbol	Test Conditions	Min.	Typ.	Max.	Units
<b>Control Sector</b>						
Supply Voltage	$V_D$	Applied between $V_{P1}$ - $V_{PC}$ , $V_{N1}$ - $V_{NC}$	13.5	15.0	16.5	Volts
	$V_{DB}$	Applied between $V_{UFB}$ - $V_{UFS}$ , $V_{VFB}$ - $V_{VFS}$ , $V_{WFB}$ - $V_{WFS}$	13.5	15.0	16.5	Volts
Circuit Current	$I_D$	$V_D = 15\text{V}$ , $V_{CIN} = 5\text{V}$ , $V_{DB} = 15\text{V}$ , Total of $V_{P1}$ - $V_{PC}$ , $V_{N1}$ - $V_{NC}$	—	—	8.50	mA
		$V_D = 15\text{V}$ , $V_{CIN} = 5\text{V}$ , $V_{DB} = 15\text{V}$ , $V_{UFB}$ - $V_{UFS}$ , $V_{VFB}$ - $V_{VFS}$ , $V_{WFB}$ - $V_{WFS}$	—	—	1.00	mA
Fault Output Voltage	$V_{FOH}$	$V_{SC} = 0\text{V}$ , $F_O$ Circuit: 10k $\Omega$ to 5V Pull-up	4.9	—	—	Volts
	$V_{FOL}$	$V_{SC} = 1\text{V}$ , $F_O$ Circuit: 10k $\Omega$ to 5V Pull-up	—	0.8	1.2	Volts
	$V_{FO(sat)}$	$V_{SC} = 1\text{V}$ , $I_{FO} = 15\text{mA}$	0.8	1.2	1.8	Volts
PWM Input Frequency	$f_{PWM}$	$T_C \leq 100^\circ\text{C}$ , $T_j \leq 125^\circ\text{C}$	—	5	—	kHz
Allowable Dead Time	$t_{DEAD}$	Relates to Corresponding Input Signal for Blocking Arm Shoot-through ( $-20^\circ\text{C} \leq T_C \leq 100^\circ\text{C}$ )	2.5	—	—	$\mu\text{S}$
Short Circuit Trip Level*	$V_{SC(ref)}$	$T_j = 25^\circ\text{C}$ , $V_D = 15\text{V}^*$	0.45	0.5	0.55	Volts
Supply Circuit Under-voltage	$UV_{DBt}$	Trip Level, $T_j \leq 125^\circ\text{C}$	10.0	—	12.0	Volts
	$UV_{DBr}$	Reset Level, $T_j \leq 125^\circ\text{C}$	10.5	—	12.5	Volts
	$UV_{Dt}$	Trip Level, $T_j \leq 125^\circ\text{C}$	10.3	—	12.5	Volts
	$UV_{Dr}$	Reset Level, $T_j \leq 125^\circ\text{C}$	10.8	—	13.0	Volts
Fault Output Pulse Width**	$t_{FO}$	$C_{FO} = 22\text{nF}$	1.0	1.8	—	mS
ON Threshold Voltage (H-side)	$V_{th(on)}$	Applied between $U_P$ , $V_P$ , $W_P$ - $V_{PC}$	0.8	1.4	2.0	Volts
OFF Threshold Voltage (H-side)	$V_{th(off)}$		2.5	3.0	4.0	Volts
ON Threshold Voltage (L-side)	$V_{th(on)}$	Applied between $U_N$ , $V_N$ , $W_N$ - $V_{NC}$	0.8	1.4	2.0	Volts
OFF Threshold Voltage (L-side)	$V_{th(off)}$		2.5	3.0	4.0	Volts

\* Short Circuit protection is functioning only at the low-arms. Please select the value of the external shunt resistor such that the SC trip level is less than 25.5A.

\*\*Fault signal is asserted when the low-arm short circuit or control supply under-voltage protective functions operate. The fault output pulse-width  $t_{FO}$  depends on the capacitance value of  $C_{FO}$  according to the following approximate equation:  $C_{FO} = (12.2 \times 10^{-6}) \times t_{FO} \{F\}$ .



Powerex, Inc., 200 Hillis Street, Youngwood, Pennsylvania 15697-1800 (724) 925-7272

**PS21245-E**  
**Intellimod™ Module**  
**Dual-In-Line Intelligent Power Module**  
 20 Amperes/600 Volts

### Thermal Characteristics

Characteristic	Symbol	Condition	Min.	Typ.	Max.	Units
Junction to Case	$R_{th(j-c)Q}$	Each IGBT	—	—	2.2	°C/Watt
	$R_{th(j-c)D}$	Each FWDi	—	—	4.5	°C/Watt
Contact Thermal Resistance	$R_{th(c-f)}$	Case to Fin Per Module. Thermal Grease Applied	—	—	0.067	°C/Watt

### Recommended Conditions for Use

Characteristic	Symbol	Condition	Min.	Typ.	Value	Units
Supply Voltage	$V_{CC}$	Applied between P-N Terminals	0	300	400	Volts
Control Supply Voltage	$V_D$	Applied between $V_{P1-V_{PC}}$ , $V_{N1-V_{NC}}$	13.5	15.0	16.5	Volts
	$V_{DB}$	Applied between $V_{UFB-V_{UFS}}$ , $V_{VFB-V_{VFS}}$ , $V_{WFB-V_{WFS}}$	13.5	15.0	16.5	Volts
Control Supply dv/dt	$dV_D/dt$ , $dV_{DB}/dt$		-1	—	1	V/ $\mu$ s
Input ON Voltage	$V_{CIN(on)}$	Applied between $U_P$ , $V_P$ , $W_P-V_{PC}$			0 ~ 0.65	Volts
Input OFF Voltage	$V_{CIN(off)}$	Applied between $U_N$ , $V_N$ , $W_N-V_{NC}$			4.0 ~ 5.5	Volts
PWM Input Frequency	$f_{PWM}$	$T_C \leq 100^\circ\text{C}$ , $T_j \leq 125^\circ\text{C}$	—	5	—	kHz
Arm Shoot-through Blocking Time	$t_{DEAD}$	For Each Input Signal	2.5	—	—	$\mu$ S

**PS21245-E**  
**Intellimod™ Module**  
**Dual-In-Line Intelligent Power Module**  
 20 Amperes/600 Volts

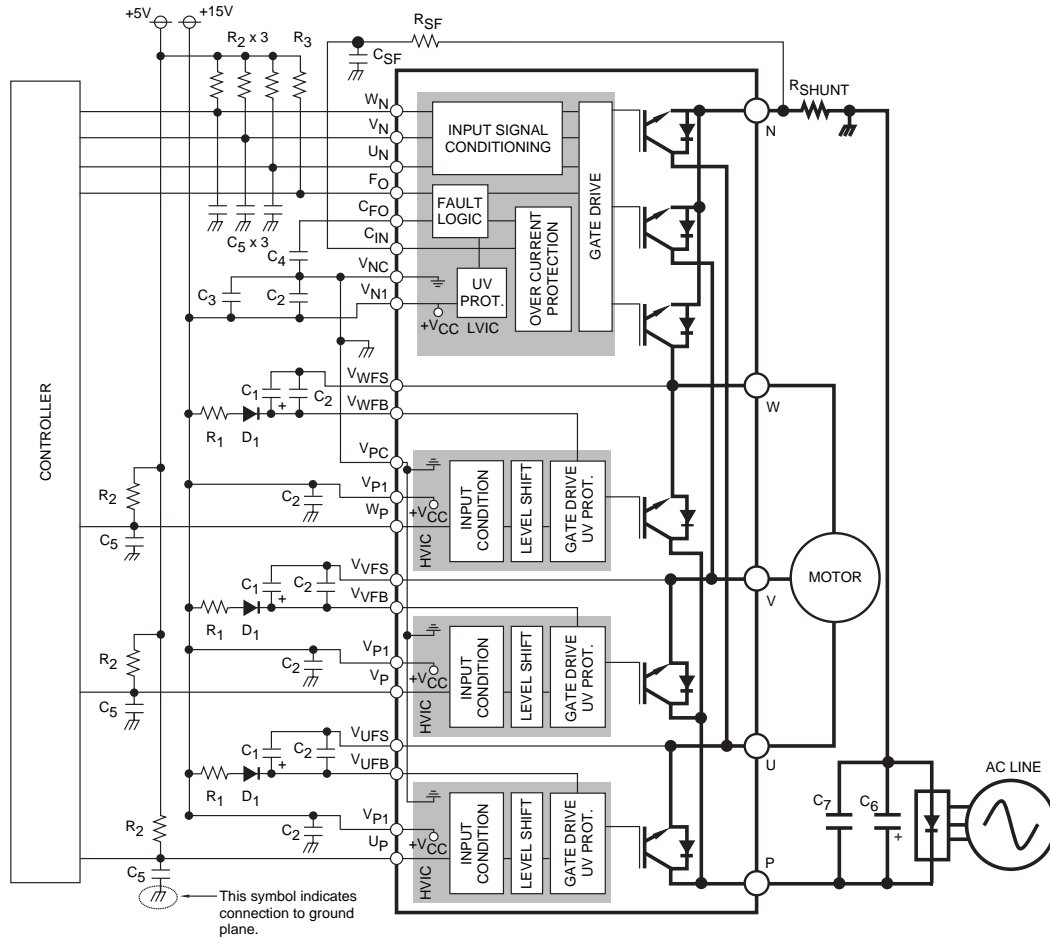

**Component Selection:**

Dsn.	Typ. Value	Description
D1	1A, 600V	Boot strap supply diode – Ultra fast recovery
C1	10-100uF, 50V	Boot strap supply reservoir – Electrolytic, long life, low Impedance, 105°C (Note 5)
C2	0.22-2.0uF, 50V	Local decoupling/High frequency noise filters – Multilayer ceramic (Note 8)
C3	1-100uF, 50V	Control power supply filter – Electrolytic, long life, low Impedance, 105°C
C4	22nF, 50V	Fault lock-out timing capacitor – Multilayer ceramic (Note 4)
C5	100-1000pF, 50V	Input signal noise filter – Multilayer ceramic (Note 1)
C6	200-2000uF, 450V	Main DC bus filter capacitor – Electrolytic, long life, high ripple current, 105°C
C7	0.1-0.22uF, 450V	Surge voltage suppression capacitor – Polyester/Polypropylene film (Note 9)
CSF	1000pF, 50V	Short circuit detection filter capacitor – Multilayer Ceramic (Note 6, Note 7)
RSF	1.8k ohm	Short circuit detection filter resistor (Note 6, Note 7)
RSHUNT	5-100 mohm	Current sensing resistor - Non-inductive, temperature stable, tight tolerance (Note 10)
R1	1-100 ohm	Boot strap supply inrush limiting resistor (Note 5)
R2	4.7k ohm	Control input pull-up resistor (Note 1, Note 2)
R3	5.1k ohm	Fault output signal pull-up resistor (Note 3)

**Notes:**

- To prevent input signal oscillations minimize wiring length to controller (~2cm). Additional RC filtering (C5 etc.) may be required. If filtering is added be careful to maintain proper dead time. See application notes for details.
- Internal HVIC provides high voltage level shifting allowing direct connection of all six driving signals to the controller.
- FO output is an open collector type. This signal should be pulled high with 5.1k ohm resistor (R3).
- C4 sets the fault output duration and lock-out time.  $C4 = 12.2E^{-6} \times t_{FO}$ , 22nF gives ~1.8ms
- Boot strap supply component values must be adjusted depending on the PWM frequency and technique.
- Wiring length associated with RSHUNT, RSF, CSF must be minimized to avoid improper operation of the OC function.
- RSF, CSF set over current protection trip time. Recommend time constant is 1.5us-2.0us. See application notes.
- Local decoupling/high frequency filter capacitors must be connected as close as possible to the modules pins.
- The length of the DC link wiring between C6, C7, the DIP's P terminal and the shunt must be minimized to prevent excessive transient voltages. In particular C7 should be mounted as close to the DIP as possible.
- Use high quality, tight tolerance current sensing resistor. Connect resistor as close as possible to the DIP's N terminal. Be careful to check for proper power rating. See application notes for calculation of resistance value.

**This datasheet has been downloaded from:**

**[www.EEworld.com.cn](http://www.EEworld.com.cn)**

**Free Download**

**Daily Updated Database**

**100% Free Datasheet Search Site**

**100% Free IC Replacement Search Site**

**Convenient Electronic Dictionary**

**Fast Search System**

**[www.EEworld.com.cn](http://www.EEworld.com.cn)**