

## SEMITRANS® M Power MOSFET Modules

### SKM 151 A4R

Preliminary Data



### SEMITRANS M1

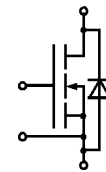

#### Features

- N Channel, enhancement mode
- Short internal connections avoid oscillations
- With built-in gate resistor chips ("R")  $R_{gtotal} = 1,3 \Omega$
- Without hard mould (environmental aspects)
- Isolated copper baseplate using DCB Direct Copper Bonding Ceramic
- All electrical connections on top for easy busbaring
- Large clearance (10 mm) and creepage distances (13 mm)
- UL recognized, file no. E63 532

#### Typical Applications

- Switched mode power supplies
- DC servo and robot drives
- DC choppers
- Resonant and welding inverters
- AC motor drives
- Laser power supplies
- UPS equipment
- Not suitable for linear amplification

**This is an electrostatic discharge sensitive device (ESDS). Please observe the international standard IEC 747-1, Chapter IX.**

Absolute Maximum Ratings		Values	Units
Symbol	Conditions <sup>1)</sup>		
$V_{DS}$		500	V
$V_{DGR}$	$R_{GE} = 20 \text{ k}\Omega$	500	V
$I_D$	$T_c = 25 / 80 \text{ }^\circ\text{C}$	70 / 50	A
$I_{DM}$	$T_c = 25 / 80 \text{ }^\circ\text{C}$	280 / 200	A
$V_{GS}$		$\pm 20$	V
$P_D$		780	W
$T_j, (T_{stg})$		-40 ... +150 (125)	$^\circ\text{C}$
$V_{isol}$	AC, 1 min.	2 500	V
humidity	DIN 40 040	Class F	
climate	DIN IEC 68 T.1	40/125/56	
Inverse Diode			
$I_F = -I_D$	$T_c = 25 / 80 \text{ }^\circ\text{C}$	70 / 50	A
$I_{FM} = -I_{DM}$	$T_c = 25 / 80 \text{ }^\circ\text{C}$	280 / 200	A

Characteristics		min.	typ.	max.	Units
Symbol	Conditions <sup>1)</sup>				
$V_{(BR)DSS}$	$V_{GS} = 0, I_D = 0,25 \text{ mA}$	500	–	–	V
$V_{GS(th)}$	$V_{GS} = V_{DS}, I_D = 1 \text{ mA}$	2,1	3,0	4,0	V
$I_{DSS}$	$V_{GS} = 0$	–	1	250	$\mu\text{A}$
	$V_{DS} = 500 \text{ V}$	–	300	1000	$\mu\text{A}$
$I_{GSS}$	$V_{GS} = 20 \text{ V}, V_{DS} = 0$	–	10	100	nA
$R_{DS(on)}$	$V_{GS} = 10 \text{ V}, I_D = 50 \text{ A}$	–	50	70	m $\Omega$
$g_{fs}$	$V_{DS} = 25 \text{ V}, I_D = 50 \text{ A}$	48	90	–	S
$C_{CHC}$		–	–	160	pF
$C_{iss}$	$V_{GS} = 0$ $V_{DS} = 25 \text{ V}$ $f = 1 \text{ MHz}$	–	15	20	nF
$C_{oss}$		–	1,9	2,9	nF
$C_{rss}$		–	0,72	1,1	nF
$L_{DS}$		–	–	30	nH
$t_{d(on)}$	$V_{DD} = 250 \text{ V}$ $I_D = 30 \text{ A}$ $V_{GS} = 10 \text{ V}$ $R_G = 4,7 \Omega$	–	60	–	ns
$t_r$		–	100	–	ns
$t_{d(off)}$		–	500	–	ns
$t_f$		–	120	–	ns
Inverse Diode					
$V_{SD}$	$I_F = 120 \text{ A}, V_{GS} = 0 \text{ V}$	–	1,0	1,4	V
$t_{rr}$	$T_j = 25 \text{ }^\circ\text{C}^2)$	–	450	–	ns
	$T_j = 150 \text{ }^\circ\text{C}^2)$	–	–	–	ns
$Q_{rr}$	$T_j = 25 \text{ }^\circ\text{C}^2)$	–	36	–	$\mu\text{C}$
	$T_j = 150 \text{ }^\circ\text{C}^2)$	–	–	–	
Thermal characteristics					
$R_{thjc}$		–	–	0,16	$^\circ\text{C/W}$
$R_{thch}$	$M_1$ , surface $10 \mu\text{m}$	–	–	0,05	$^\circ\text{C/W}$

Mechanical Data				
$M_1$	to heatsink, SI Units	4	–	6
	to heatsink, US Units	35	–	53
$M_2$	for terminals, SI Units	2,5	–	3,5
	for terminals, US Units	22	–	24
a		–	–	5x9,81
w		–	–	150
Case	page 5	D15		

<sup>1)</sup>  $T_{case} = 25 \text{ }^\circ\text{C}$ , unless otherwise specified

<sup>2)</sup>  $I_F = -I_D, V_R = 100 \text{ V}, -di_F/dt = 100 \text{ A}/\mu\text{s}$

Do not parallel with former SKM 151 or SKM 151F (which are discontinued)

SKM 151 A4R can replace SKM 151, former SKM 151 R and SKM 151 AR

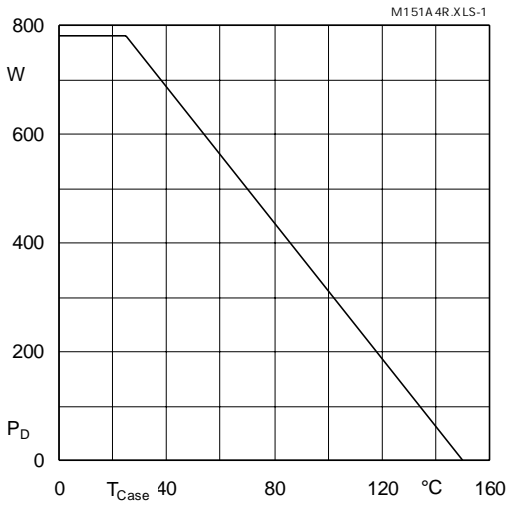

Fig. 1 Rated power dissipation vs. temperature

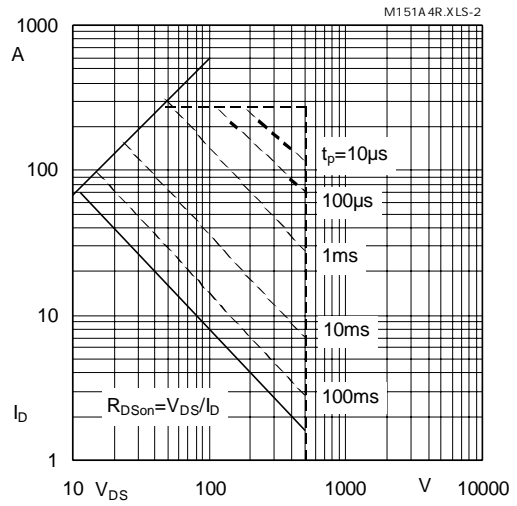

Fig. 2 Maximum safe operating area

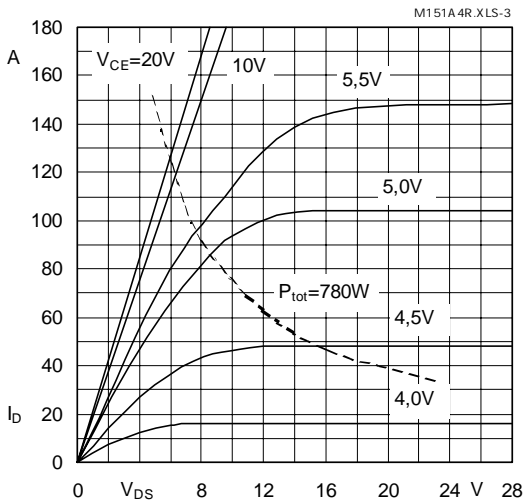

Fig. 3 Output characteristic

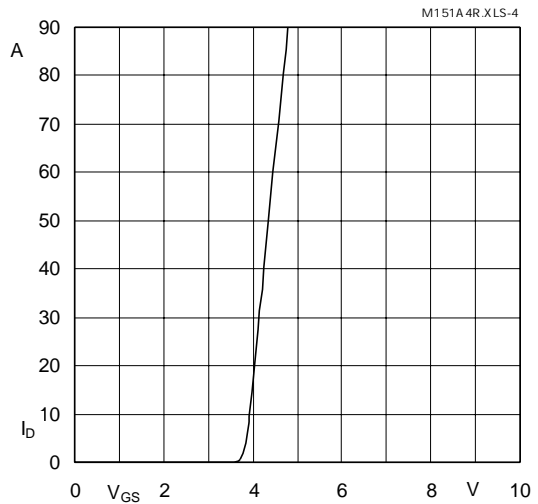

Fig. 4 Transfer characteristic

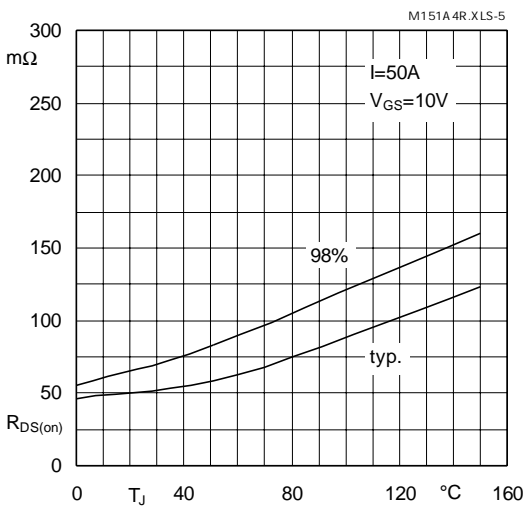

Fig. 5 On-resistance vs. temperature

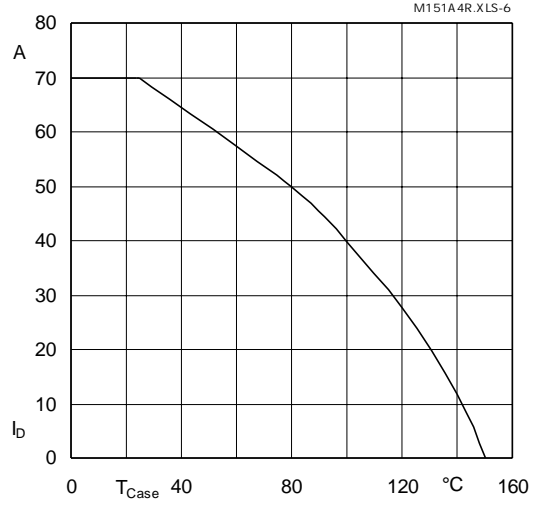

Fig. 6 Rated current vs. temperature

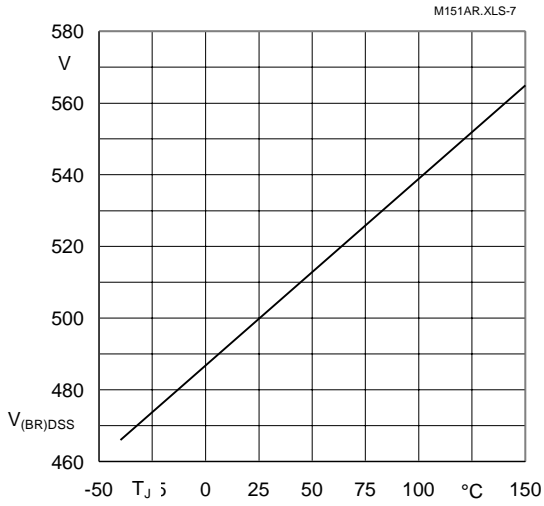

Fig. 7 Breakdown voltage vs. temperature

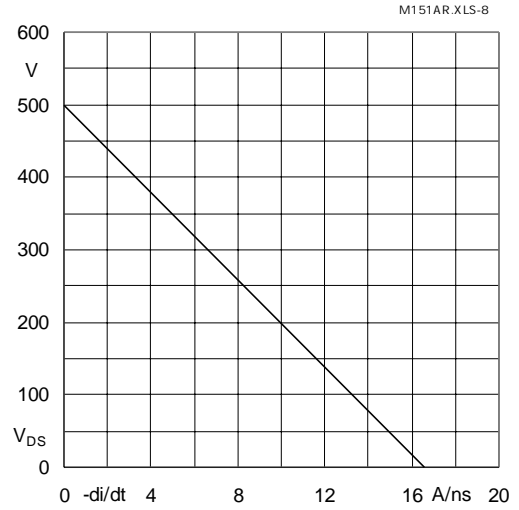

Fig. 8 Drain-source voltage derating

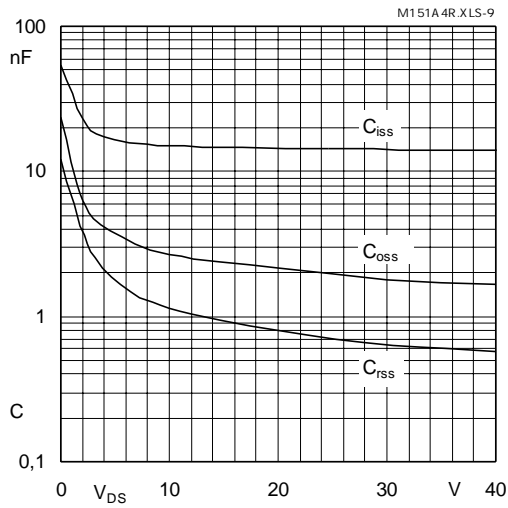

Fig. 9 Capacitances vs. drain-source voltage

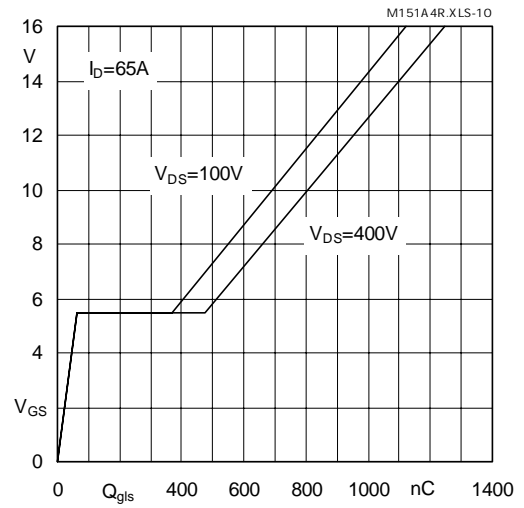

Fig. 10 Gate charge characteristic

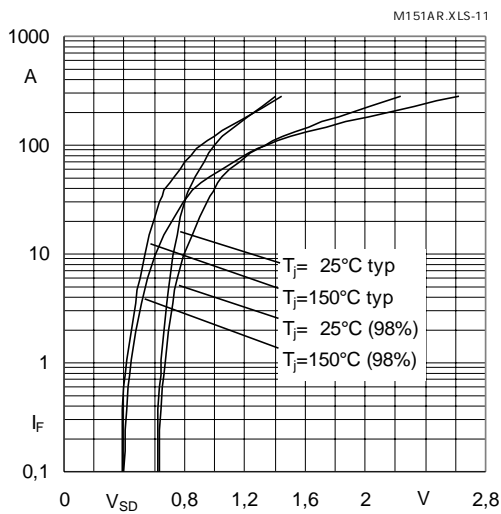

Fig. 11 Diode forward characteristic

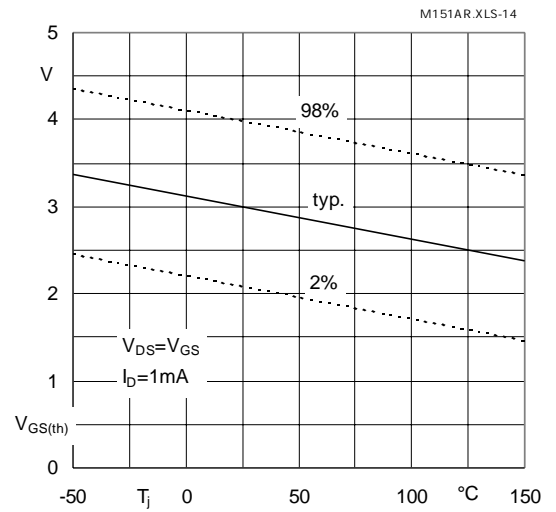

Fig. 14 Gate-source threshold voltage

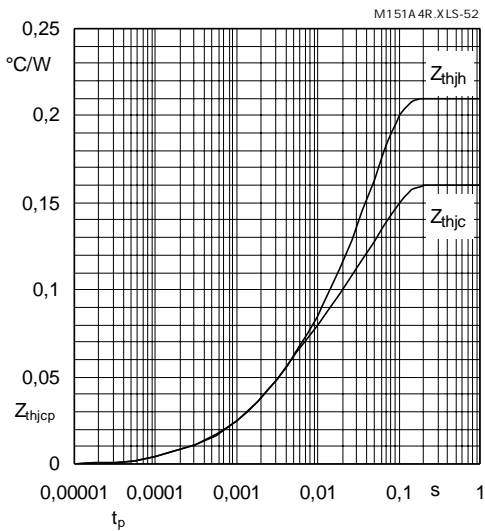

Fig. 51 Transient thermal impedance

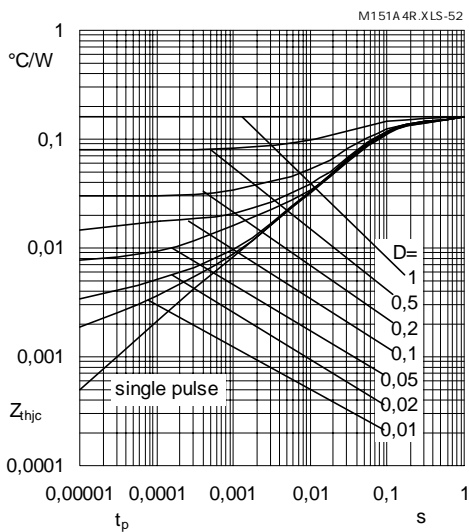

Fig. 52 Thermal impedance under pulse conditions

### SEMITRANS M 1

Case D 15

UL recognized, file No. E63 5632

### SKM 151 A4R

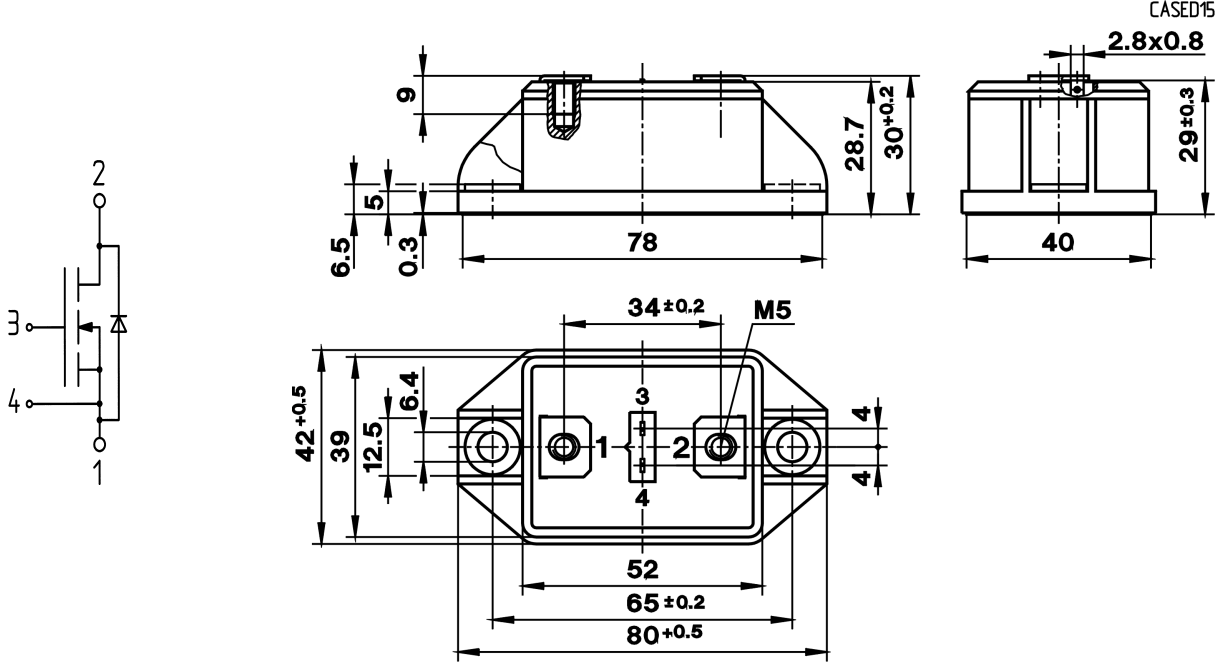

Outline and circuit diagram