

PM200DVA120

FLAT-BASE TYPE
INSULATED PACKAGE

PM200DVA120



FEATURE

- 3φ 200A, 1200V Current-sense IGBT for 20kHz switching
 - Monolithic gate drive & protection logic
 - Detection, protection & status indication circuits for over-current, short-circuit, over-temperature & under-voltage (P-Fo available from upper leg devices)
 - Acoustic noise-less 37kW class inverter application
 - UL Recognized
- Yellow Cord No. E80276(N)
File No. E80271

APPLICATION

General purpose inverter, servo drives and other motor controls

PACKAGE OUTLINES

Dimensions in mm

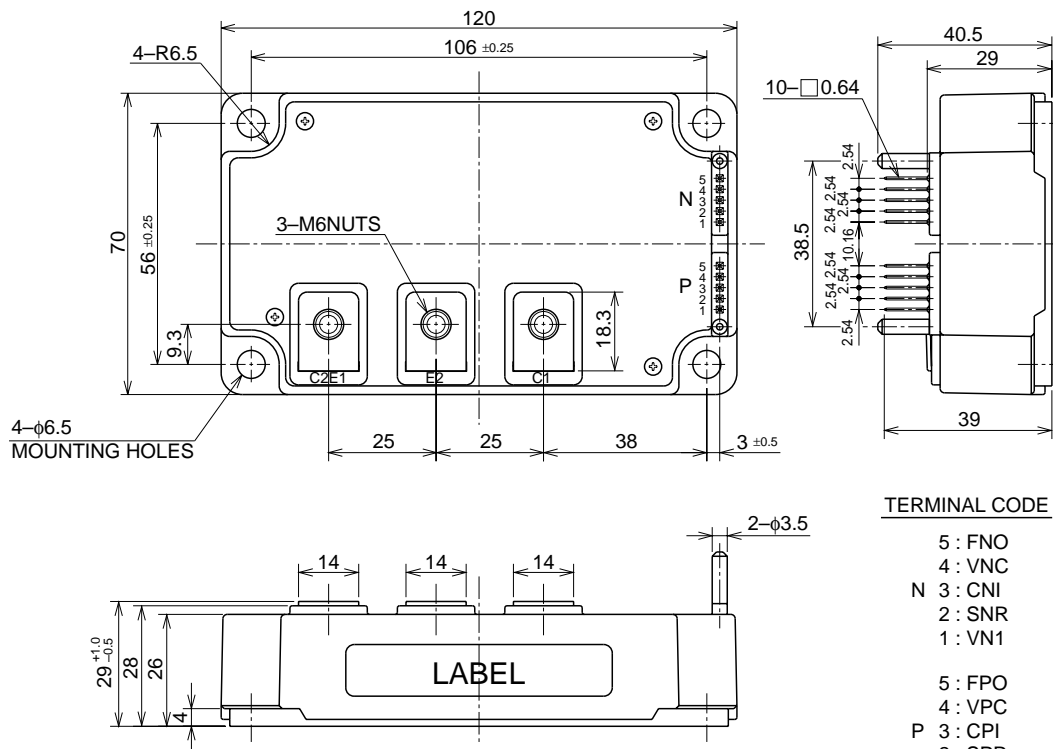

TERMINAL CODE

- 5 : FNO
4 : VNC
N 3 : CNI
2 : SNR
1 : VN1
- 5 : FPO
4 : VPC
P 3 : CPI
2 : SPR
1 : VP1

PM200DVA120

FLAT-BASE TYPE
INSULATED PACKAGE

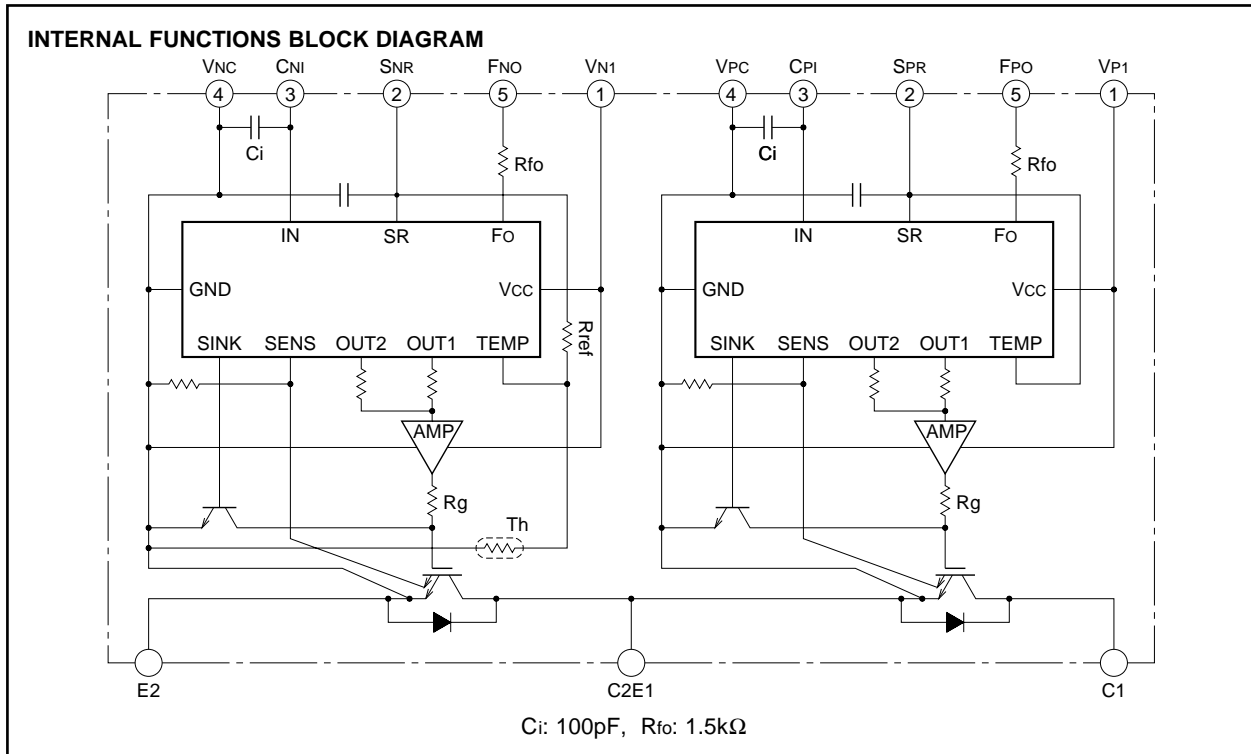

MAXIMUM RATINGS (Tj = 25°C, unless otherwise noted)

INVERTER PART

Symbol	Parameter	Condition	Ratings	Unit
VCES	Collector-Emitter Voltage	V _D = 15V, V _{CIN} = 5V	1200	V
±IC	Collector Current	T _C = 25°C	200	A
±ICP	Collector Current (Peak)	T _C = 25°C	400	A
PC	Collector Dissipation	T _C = 25°C	1033	W
Tj	Junction Temperature		-20 ~ +150	°C

CONTROL PART

Symbol	Parameter	Condition	Ratings	Unit
V _D	Supply Voltage	Applied between : VP1-VPC, VN1-VNC	20	V
V _{CIN}	Input Voltage	Applied between : CPI-VPC, CNI-VNC	10	V
V _{FO}	Fault Output Supply Voltage	Applied between : FPO-VPC, FNO-VNC	20	V
I _{FO}	Fault Output Current	Sink current at FPO, FNO terminal	20	mA

PM200DVA120

FLAT-BASE TYPE
INSULATED PACKAGE

TOTAL SYSTEM

Symbol	Parameter	Condition	Ratings	Unit
V _{CC(Prot)}	Supply Voltage Protected by SC	V _D = 13.5 ~ 16.5V, Inverter Part, T _j = 125°C Start	800	V
V _{CC(surge)}	Supply Voltage (Surge)	Applied between : C1-E2, Surge value or without switching	1000	V
T _C	Module Case Operating Temperature		-20 ~ +100	°C
T _{stg}	Storage Temperature		-40 ~ +125	°C
V _{iso}	Isolation Voltage	60Hz, Sinusoidal, Charged part to Base, AC 1 min.	2500	V _{rms}

ELECTRICAL CHARACTERISTICS (T_j = 25°C, unless otherwise noted)

INVERTER PART

Symbol	Parameter	Test Condition	Limits			Unit	
			Min.	Typ.	Max.		
V _{CE(sat)}	Collector-Emitter Saturation Voltage	V _D = 15V, I _C = 200A V _{CIN} = 0V	T _j = 25°C	—	2.65	3.30	V
			T _j = 125°C	—	2.75	3.35	
V _{EC}	FWDi Forward Voltage	-I _C = 200A, V _D = 15V, V _{CIN} = 5V	—	2.50	3.50	V	
t _{on}	Switching Time	V _D = 15V, I _{CIN} = 0V↔5V V _{CC} = 600V, I _C = 200A T _j = 125°C Inductive Load (upper and lower arm)	0.4	0.9	2.3	μs	
t _{rr}			—	0.2	0.3		
t _{c(on)}			—	0.4	1.0		
t _{off}			—	2.4	3.4		
t _{c(off)}			—	0.7	1.2		
I _{CES}	Collector-Emitter Cutoff Current	V _{CE} = V _{CEs} , V _D = 15V	T _j = 25°C	—	—	1	mA
			T _j = 125°C	—	—	10	

CONTROL PART

Symbol	Parameter	Test Condition	Limits			Unit	
			Min.	Typ.	Max.		
I _D	Circuit Current	V _D = 15V, V _{CIN} = 5V	V _{N1} -V _{NC}	—	27	38	mA
			V _{P1} -V _{PC}	—	27	38	
V _{th(ON)}	Input ON Threshold Voltage	Applied between : C _{P1} -V _{PC} , C _{N1} -V _{NC}	1.2	1.5	1.8	V	
V _{th(OFF)}	Input OFF Threshold Voltage		1.7	2.0	2.3		
SC	Short Circuit Trip Level	-20 ≤ T _j ≤ 125°C, V _D = 15V	240	—	—	A	
t _{off(SC)}	Short Circuit Current Delay Time	V _D = 15V	—	10	—	μs	
OT _r	Over Temperature Protection (Lower-arms only)	Base-plate Temperature detection, V _D = 15V	Trip level	111	118	125	°C
			Reset level	—	100	—	
UV	Supply Circuit Under-Voltage Protection	-20 ≤ T _j ≤ 125°C	Trip level	11.5	12.0	12.5	V
			Reset level	—	12.5	—	
I _{FO(H)}	Fault Output Current (Note-1)	V _D = 15V, V _{FO} = 15V	—	—	0.01	mA	
I _{FO(L)}			—	10	15		
t _{FO}	Minimum Fault Output Pulse Width (Note-1)	V _D = 15V	1.0	1.8	—	ms	
V _{SXR}	SXR Terminal Output Voltage	-20 ≤ T _j ≤ 125°C, R _{in} = 6.8kΩ	4.5	5.1	5.6	V	

(Note-1) Fault output is given only when the internal SC, OT & UV protection.
 Fault output of OT protection operate by lower arm
 Fault output of OT, UV protection given pulse while over level.

PM200DVA120FLAT-BASE TYPE
INSULATED PACKAGE**THERMAL RESISTANCES**

Symbol	Parameter	Test Condition	Limits			Unit
			Min.	Typ.	Max.	
R _{th(j-c)Q}	Junction to case Thermal Resistances	Inverter IGBT part (per 1/2 module)	—	—	0.121	°C/W
R _{th(j-c)F}		Inverter FWDi part (per 1/2 module)	—	—	0.18	
R _{th(c-f)}	Contact Thermal Resistance	Case to fin, Thermal grease applied (per 1/2 module)	—	—	0.075	

MECHANICAL RATINGS AND CHARACTERISTICS

Symbol	Parameter	Test Condition	Limits			Unit
			Min.	Typ.	Max.	
—	Mounting torque	Mounting part screw : M6	3.92	4.90	5.88	N • m
—	Mounting torque	Main terminal screw : M6	3.92	4.90	5.88	N • m
—	Weight		—	510	—	g

RECOMMENDED CONDITIONS FOR USE

Symbol	Parameter	Test Condition	Recommended value	Unit
V _{CC}	Supply Voltage	Applied across C1-E2 terminals	≤ 800	V
V _D	Control Supply Voltage	Applied between : VP1-VPC, VN1-VNC	15 ± 1.5	V
V _{CIN(ON)}	Input ON Voltage	Applied between : CPI-VPC, CNI-VNC	≤ 0.8	V
V _{CIN(OFF)}	Input OFF Voltage		≥ 4.0	
t _{dead}	Arm Shoot-through Blocking Time	For IPM's each input signals	≥ 3.5	μs
f _{PWM}	PWM Input Frequency	Using Application Circuit input signal of IPM, 3φ Sinusoidal PWM VVVF inverter	≤ 20	kHz

PM200DVA120

FLAT-BASE TYPE
INSULATED PACKAGE

PERFORMANCE CURVES

OUTPUT CHARACTERISTICS (TYPICAL)

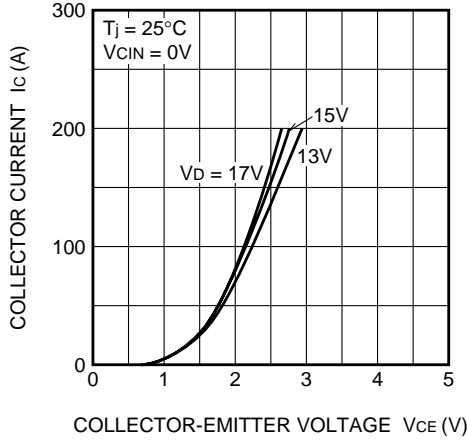

COLLECTOR-EMITTER SATURATION VOLTAGE CHARACTERISTICS (TYPICAL)

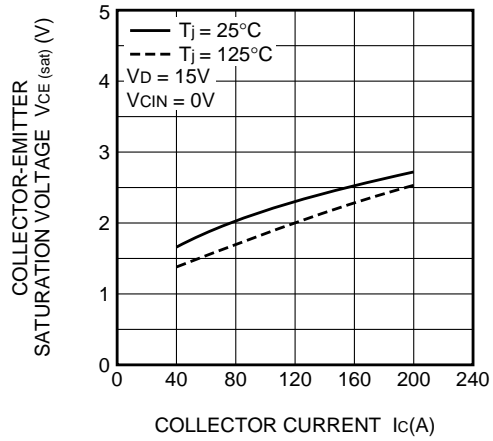

COLLECTOR-EMITTER SATURATION VOLTAGE CHARACTERISTICS (TYPICAL)

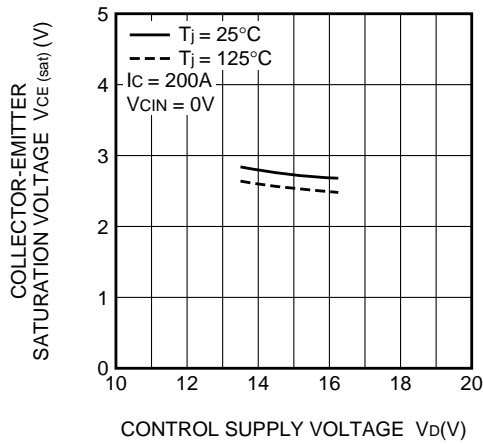

SWITCHING CHARACTERISTICS (TYPICAL)

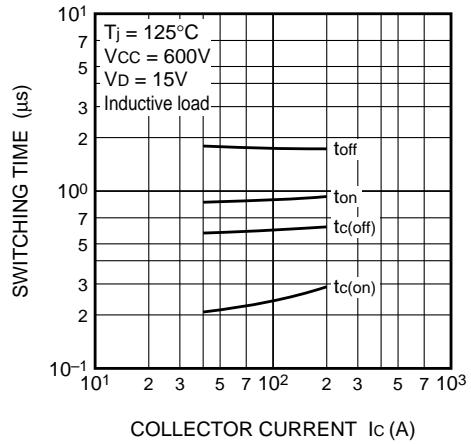

DIODE FORWARD CHARACTERISTICS (TYPICAL)

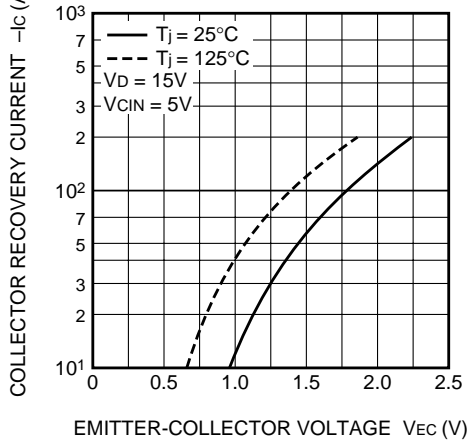

DIODE REVERSE RECOVERY CHARACTERISTICS (TYPICAL)

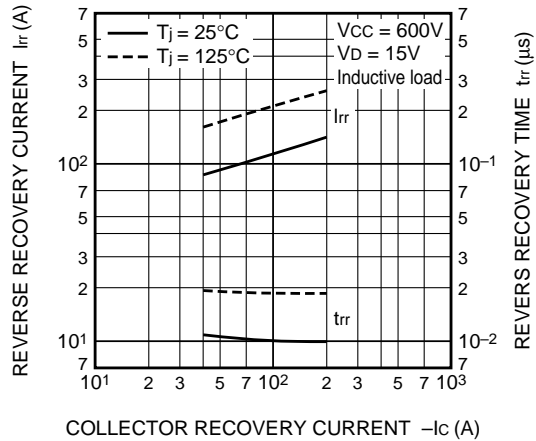

PM200DVA120

FLAT-BASE TYPE
INSULATED PACKAGE

