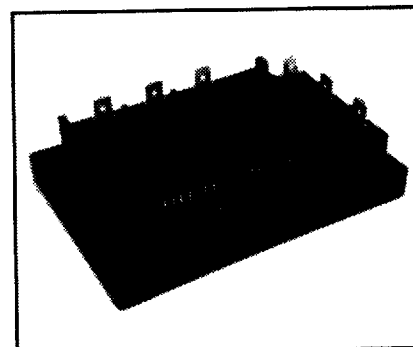
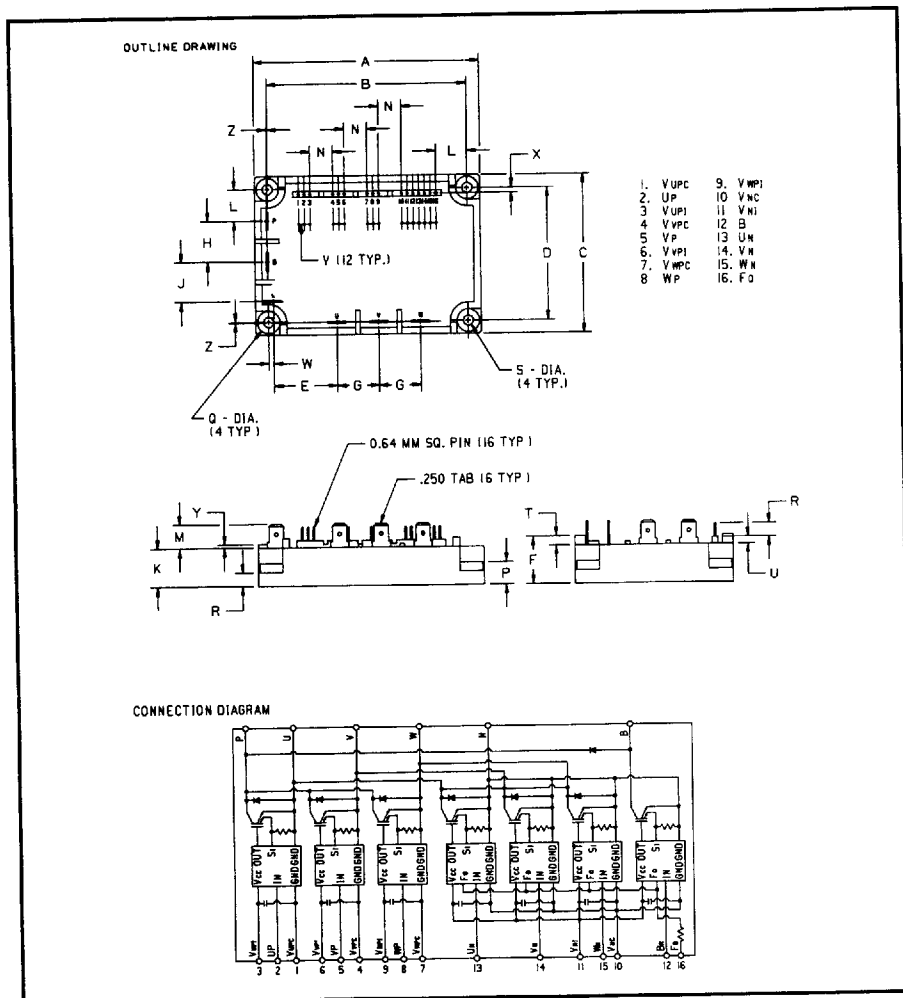




Powerex, Inc., Hillis Street, Youngwood, Pennsylvania 15697 (412) 925-7272  
 Powerex, Europe, S.A. 428 Avenue G. Durand, BP107, 72003 Le Mans, France (43) 41.14.14

**Intellimod™-3 Modules**  
**Three Phase + Brake**  
**IGBT Inverter Output**  
**10 Amperes/460 Volt Line**



**Description**

Powerex Intellimod-3 Modules are designed for applications requiring a high frequency (20kHz) output switching inverter. The modules are isolated from the baseplate, consisting of complete drive, control and protection circuitry for the IGBT inverter.

**Features:**

- Complete Output Power Circuit
- Gate Drive Circuit
- Protection Logic
  - Short Circuit
  - Over-Current
  - Over Temperature
  - Under Voltage

**Applications:**

- Inverters
- Small UPS
- Motion/Servo Control
- AC Motor Control

**Ordering Information**

PM10RHB120

460 Volt Line, PM10RHB120 Outline Drawing

Dimensions	Inches	Millimeters
A	3.96±0.04	100.5±1.0
B	3.48±0.02	88.5±0.5
C	2.76±0.04	70.0±1.0
D	2.30±0.02	58.5±0.5
E	1.191	30.25
F	0.83	21.0
G	0.73	18.5
H	0.71	18.0
J	0.69	17.5
K	0.67	17.0
L	0.541	13.75
M	0.41	10.5

Dimensions	Inches	Millimeters
N	0.4	10.16
P	0.39	10.0
Q	0.39 Dia.	10.0 Dia.
R	0.24	6.0
S	0.18 Dia.	4.5 Dia.
T	0.16	4.0
U	0.12	3.0
V	0.1	2.54
W	0.088	2.25
X	0.086	2.18
Y	0.06	1.5
Z	0.001	0.25



POWEREX INC

51E D ■ 7294621 0005749 T39 ■ PRX

Powerex, Inc., Hillis Street, Youngwood, Pennsylvania 15697 (412) 925-7272

Powerex, Europe, S.A. 428 Avenue G. Durand, BP107, 72003 Le Mans, France (43) 41.14.14

PM10RHB120

Intellimod-3 Modules

Three Phase + Brake IGBT Inverter Output

10 Amperes/460 Volt Line

T-57-29

**Absolute Maximum Ratings,  $T_j = 25\text{ }^\circ\text{C}$  unless otherwise specified**

Characteristics	Symbol	PM10RHB120	Units
Power Device Junction Temperature	$T_j$	-20 to +150	$^\circ\text{C}$
Storage Temperature	$T_{STG}$	-40 to +125	$^\circ\text{C}$
Case Operating Temperature	$T_C$	-20 to +100	$^\circ\text{C}$
Mounting Torque, M4 Mounting Screws	—	15	Kg-cm
Module Weight (Typical)	—	330	Grams
Supply Voltage Protected by OC and SC ( $V_D = 13.5 - 16.5\text{V}$ , Inverter Part)	$V_{CC(prot.)}$	800	Volts
Isolation Voltage AC 1 minute, 60Hz	$V_{RMS}$	2500	Volts

**Control Sector**

Supply Voltage Applied between ( $V_{UP1} - V_{UPC}$ , $V_{VP1} - V_{VPC}$ , $V_{WP1} - V_{WPC}$ , $V_{N1} - V_{NC}$ )	$V_D$	20	Volts
Input Voltage Applied between ( $U_P - U_{PC}$ , $V_P - V_{PC}$ , $W_P - W_{PC}$ , $U_N$ , $V_N$ , $W_N$ , $B_T$ )	$V_{CIN}$	20	Volts
Fault Output Supply Voltage (Applied between $F_O - V_{NC}$ )	$V_{FO}$	20	Volts
Fault Output Current	$I_{FO}$	20	mA

**IGBT Inverter Sector**

Collector-Emitter Voltage Fig. 1	$V_{CES}$	1200	Volts
Collector Current $\pm$	$I_C$	10	Amperes
Peak Collector Current $\pm$	$I_{CP}$	20	Amperes
Supply Voltage (Applied between P - N)	$V_{CC}$	900	Volts
Supply Voltage (Surge) Applied between P - N	$V_{CC(surge)}$	1000	Volts
Collector Dissipation	$P_C$	63	Watts

**Brake Sector**

Collector-Emitter Voltage Fig. 1	$V_{CES}$	1200	Volts
Collector Current $\pm$	$I_C$	10	Amperes
Peak Collector Current $\pm$	$I_{CP}$	20	Amperes
Supply Voltage (Applied between P - N)	$V_{CC}$	900	Volts
Supply Voltage (Surge) Applied between P - N	$V_{CC(surge)}$	1000	Volts
Collector Dissipation	$P_C$	25	Watts
Diode Forward Current	$I_F$	10	Amperes
Diode DC Reverse Voltage	$V_{R(DC)}$	1200	Volts



POWEREX INC

51E D ■ 7294621 0005750 750 ■ PRX

Powerex, Inc., Hillis Street, Youngwood, Pennsylvania 15697 (412) 925-7272  
 Powerex, Europe, S.A. 428 Avenue G. Durand, BP107, 72003 Le Mans, France (43) 41.14.14

T-57-29

PM10RHB120  
 Intellimod-3 Modules  
 Three Phase + Brake IGBT Inverter Output  
 10 Amperes/460 Volt Line

**Electrical Characteristics,  $T_j = 25^\circ\text{C}$  unless otherwise specified**

Characteristics	Symbol	Test Conditions	Min.	Typ.	Max.	Units
<b>Control Sector</b>						
Overcurrent Trip Level Inverter Part	OC	$-20^\circ\text{C} \leq T \leq 125^\circ\text{C}, V_D = 15\text{V}$	15	30	—	Amperes
Overcurrent Trip Level Brake Part			15	30	—	Amperes
Short Circuit Trip Level Inverter Part	SC	$-20^\circ\text{C} \leq T \leq 125^\circ\text{C}, V_D = 15\text{V}$	35	70	—	Amperes
Short Circuit Trip Level Brake Part			—	70	—	Amperes
Over Current Delay Time	$t_{\text{off(OC)}}$	$V_D = 15\text{V}$ , Fig. 7	—	10	—	$\mu\text{S}$
Over Temperature Protection	OT	Trip Level	—	118	—	$^\circ\text{C}$
Over Temperature Protection	$\text{OT}_R$	Reset Level	—	100	—	$^\circ\text{C}$
Supply Circuit Under Voltage Protection	UV	Trip Level	11.5	12.0	12.5	Volts
Supply Circuit Under Voltage Protection	$\text{UV}_R$	Reset Level	—	12.5	—	Volts
Supply Voltage	$V_D$	Applied between $V_{\text{UP1}} - V_{\text{UPC}}, V_{\text{VP1}} - V_{\text{VPC}}, V_{\text{WP1}} - V_{\text{WPC}}, V_{\text{N1}} - V_{\text{NC}}$	13.5	15	16.5	Volts
Circuit Current	$I_D$	$V_D = 15\text{V}, V_{\text{CIN}} = 5\text{V}, V_{\text{N1}} - V_{\text{NC}}$	—	80	120	mA
	$I_D$	$V_D = 15\text{V}, V_{\text{CIN}} = 5\text{V}, V_{\text{XP1}} - V_{\text{XPC}}$	—	25	35	mA
Input Bias On Voltage	$V_{\text{CIN(on)}}$	Applied between $U_P - V_{\text{UPC}}, V_P - V_{\text{VPC}}, W_P - V_{\text{WPC}}, U_N, V_N, W_N, Br - V_{\text{NC}}$	1.2	1.5	1.8	Volts
Input Bias Off Voltage	$V_{\text{CIN(off)}}$		1.7	2.0	2.3	Volts
PWM Input Frequency	$f_{\text{PWM}}$	3- $\emptyset$ Sinusoidal	—	15	20	kHz
Dead Time	$t_{\text{DEAD}}$	For each Input Pulse	3.0	—	—	$\mu\text{S}$
		Using example Interface Circuit*	5.0	—	—	$\mu\text{S}$
Fault Output Current	$I_{\text{FO(H)}}$	$V_D = 15\text{V}, V_{\text{FO}} = 15\text{V}$	—	—	0.01	mA
	$I_{\text{FO(L)}}$	$V_D = 15\text{V}, V_{\text{FO}} = 15\text{V}$	—	10	15	mA
Minimum Fault Output Pulse Width	$t_{\text{FO}}$	$V_D = 15\text{V}$	1.0	2.0	—	mS
<b>Brake Sector</b>						
Collector Emitter Saturation Voltage	$V_{\text{CE(sat)}}$	$V_D = 15\text{V}, V_{\text{CIN}} = 0\text{V}, I_C = 10\text{A}, T_j = 25^\circ\text{C}$ , Fig. 2	—	2.8	3.8	Volts
		$V_D = 15\text{V}, V_{\text{CIN}} = 0\text{V}, I_C = 10\text{A}, T_j = 125^\circ\text{C}$ , Fig. 2	—	2.5	3.5	Volts
Diode Forward Voltage	$V_{\text{FM}}$	$-I_C = 10\text{A}, V_D = 15\text{V}, V_{\text{CIN}} = 15\text{V}$ , Fig. 3	—	1.9	3.0	Volts
Collector Cutoff Current	$I_{\text{CEX}}$	$V_{\text{CE}} = V_{\text{CES}}, T_j = 25^\circ\text{C}$ , Fig. 6	—	—	1	mA
		$V_{\text{CE}} = V_{\text{CES}}, T_j = 125^\circ\text{C}$ , Fig. 6	—	—	10	mA

\*See Intellimod-3 Applications Data Section 4.3.



POWEREX INC

51E D ■ 7294621 0005751 697 ■ PRX

Powerex, Inc., Hillis Street, Youngwood, Pennsylvania 15697 (412) 925-7272

Powerex, Europe, S.A. 428 Avenue G. Durand, BP107, 72003 Le Mans, France (43) 41.14.14

PM10RHB120

Intellimod-3 Modules

Three Phase + Brake IGBT Inverter Output

10 Amperes/460 Volt Line

T-57-29

### Electrical Characteristics, $T_J = 25^\circ\text{C}$ unless otherwise specified

Characteristics	Symbol	Test Conditions	Min.	Typ.	Max.	Units
<b>IGBT Inverter Sector</b>						
Collector Cutoff Current	$I_{CES}$	$V_{CE} = V_{CES}, T_J = 25^\circ\text{C}$ , Fig. 6	–	–	1	mA
Collector Cutoff Current	$I_{CES}$	$V_{CE} = V_{CES}, T_J = 125^\circ\text{C}$ , Fig. 6	–	–	10.0	mA
Diode Forward Voltage	$V_{FM}$	$I_C = 10\text{A}, V_D = 15\text{V}, V_{CIN} = 15\text{V}$ , Fig. 3	–	1.9	3.0	Volts
Collector Emitter Saturation Voltage	$V_{CE(sat)}$	$V_D = 15\text{V}, V_{CIN} = 0\text{V}, I_C = 10\text{A}$ , Fig. 2	–	2.8	3.8	Volts
Collector Emitter Saturation Voltage	$V_{CE(sat)}$	$V_D = 15\text{V}, V_{CIN} = 0\text{V}, I_C = 10\text{A}$ , $T_J = 125^\circ\text{C}$ , Fig. 2	–	2.5	3.5	Volts
Inductive Load Switching Times	$t_{on}$	$V_D = 15\text{V}, V_{CIN} = 0\text{V}$ ,	0.5	1.0	2.5	$\mu\text{S}$
	$t_{rr}$	$V_{CC} = 600\text{V}, I_C = 10\text{A}$ ,	–	0.3	0.6	$\mu\text{S}$
	$t_{C(on)}$	$T_J = 125^\circ\text{C}$	–	0.5	1.5	$\mu\text{S}$
	$t_{off}$	Fig. 4, 5	–	2.0	3.5	$\mu\text{S}$
	$t_{C(off)}$		–	0.6	1.2	$\mu\text{S}$

### Thermal Characteristics

Characteristics	Symbol	Test Conditions	Min.	Typ.	Max.	Units
Thermal Resistances Junction to Case	$R_{th(j-c)Q}$	Inverter IGBT	–	–	2.0	$^\circ\text{C/W}$
	$R_{th(j-c)F}$	Inverter FWD	–	–	6.2	$^\circ\text{C/W}$
	$R_{th(j-c)Q}$	Brake IGBT	–	–	5.0	$^\circ\text{C/W}$
	$R_{th(j-c)F}$	Brake FWD	–	–	6.2	$^\circ\text{C/W}$
Contact Thermal Resistance	$R_{th(c-f)}$	Case to Fin, Thermal Grease Applied	–	–	0.25	$^\circ\text{C/W}$

### Recommended Operating Conditions

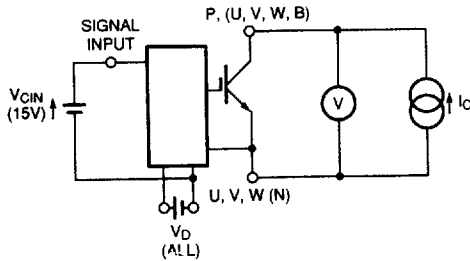
Characteristics	Symbol	Test Conditions	Value	Units
Supply Voltage	$V_{CC}$	Applied across P - N Terminals	0 ~ 800	Volts
	$V_D$	Applied between $V_{UP1} - V_{UPC}$ , $V_{N1} - V_{NC}$ , $V_{VP1} - V_{VPC}$ , $V_{WP1} - V_{WPC}$	$15 \pm 1.5$	Volts
Input On Current	$V_{CIN(on)}$	Applied between $U_P - V_{UPC}$ , $V_P - V_{VPC}$ ,	0 ~ 0.8	Volts
Input Off Current	$V_{CIN(off)}$	$W_P - V_{WPC}$ , $U_N$ , $V_N$ , $W_N$ , $Br - V_{NC}$	4 ~ 15	Volts
PWM Input Frequency	$f_{PWM}$	Using example Interface Circuit*	5 ~ 20	KHz
Minimum Dead Time	$t_{DEAD}$	Using example Interface Circuit*	5.0	$\mu\text{S}$

\*See Intellimod-3 Applications Data Section 4.3.

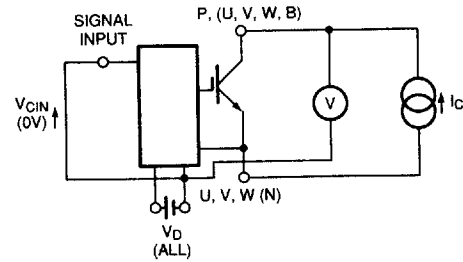
Powerex, Inc., Hillis Street, Youngwood, Pennsylvania 15697 (412) 925-7272  
 Powerex, Europe, S.A. 428 Avenue G. Durand, BP107, 72003 Le Mans, France (43) 41.14.14

T-57-29

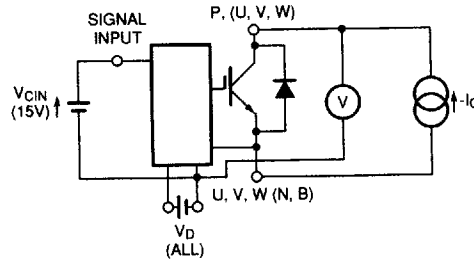
**PM10RHB120**  
**IntelliMod-3 Modules**  
**Three Phase +Brake IGBT Inverter Output**  
 10 Amperes/460 Volts



**Figure 1  $V_{CES}$  Test**

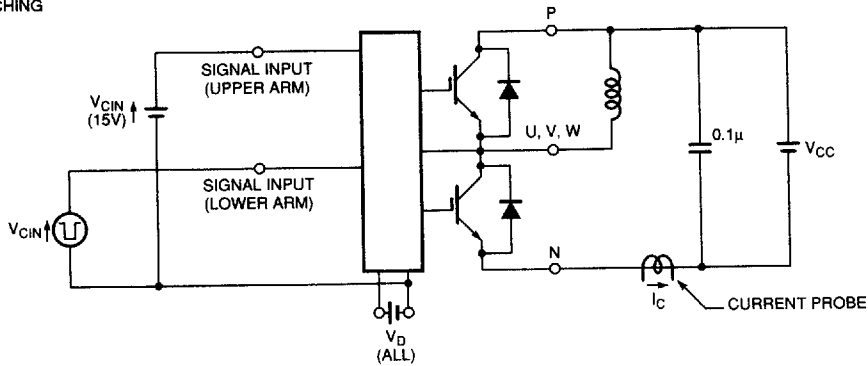


**Figure 2  $V_{CE(SAT)}$  Test**

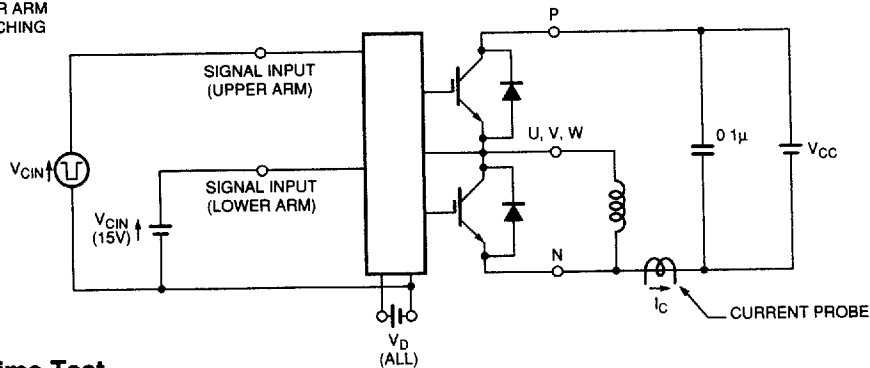


**Figure 3  $V_{EC}$  Test**

A) LOWER ARM SWITCHING



B) UPPER ARM SWITCHING



**Figure 4 Switching Time Test**

T-57-29

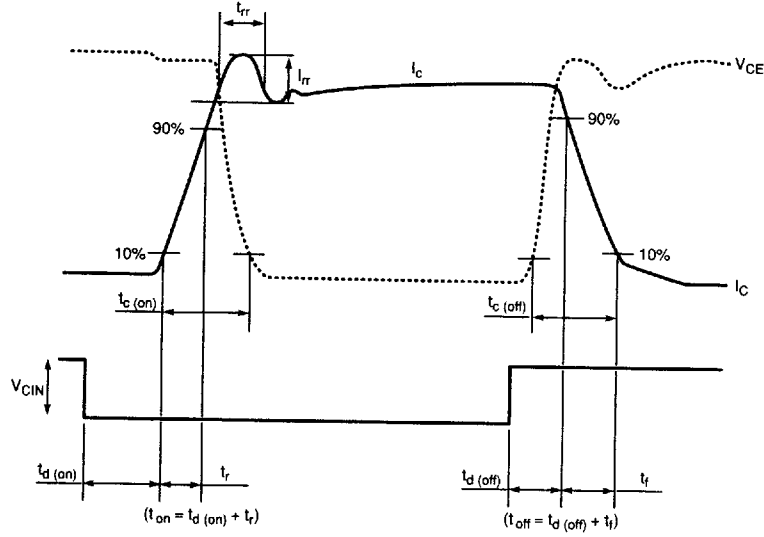


Figure 5 Switching Test Waveform

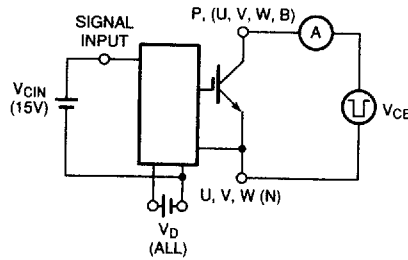


Figure 6  $I_{CES}$  Test

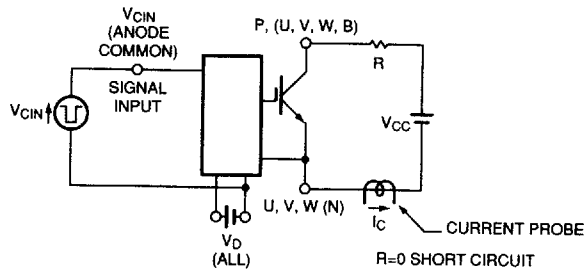


Figure 7 Over Current and Short Circuit Test