

DIODE MODULE 150A/300 to 800V PH1503,PH1504,PH1508

FEATURES

- * Isolated Base
- * High Surge Capability
- * UL Recognized, File No. E187184

TYPICAL APPLICATIONS

- * Rectified For General Use

OUTLINE DRAWING

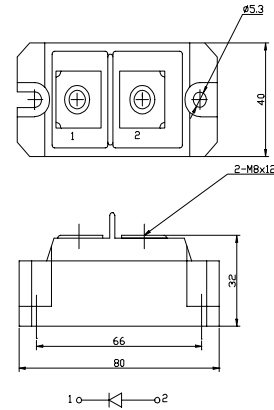

Approx Net Weight:220g

Maximum Ratings

Parameter	Symbol	Type / Grade			Unit
		PH1503	PH1504	PH1508	
Repetitive Peak Reverse Voltage	V_{RRM}	300	400	800	V
Non Repetitive Peak Reverse Voltage	V_{RSM}	400	500	900	

Parameter		Conditions	Max Rated Value	Unit	
Average Rectified Output Current	$I_{O(AV)}$	50Hz Half Sine Wave condition $T_c=103^{\circ}C$	150	A	
RMS Forward Current	$I_{F(RMS)}$		235	A	
Surge Forward Current	I_{FSM}	50 Hz Half Sine Wave,1Pulse Non-repetitive	3200	A	
I Squared t	I^2t	2msec to 10msec	51200	A ² s	
Operating JunctionTemperature Range	T_{jw}		-40 to +150	$^{\circ}C$	
Storage Temperature Range	T_{stg}		-40 to +125	$^{\circ}C$	
Isolation Voltage	Viso	Base Plate to Terminals, AC1min	2000	V	
Mounting torque	Case mounting	Ftor	M5 Screw	2.4 to 2.8	N.m
	Terminals		M8 Screw	9.0 to 10.0	

Electrical • Thermal Characteristics

Characteristics	Symbol	Test Conditions	Max.	Unit
Peak Reverse Current	I_{RM}	$V_{RM}= V_{RRM}, T_j= 150^{\circ}C$	15	mA
Peak Forward Voltage	V_{FM}	$I_{FM}= 450A, T_j=25^{\circ}C$	1.28	V
Thermal Resistance	$R_{th(j-c)}$	Junction to Case	0.25	$^{\circ}C/W$
	$R_{th(c-f)}$	Base Plate to Heat Sink with Thermal Compound	0.1	

PH150x OUTLINE DRAWING (Dimensions in mm)

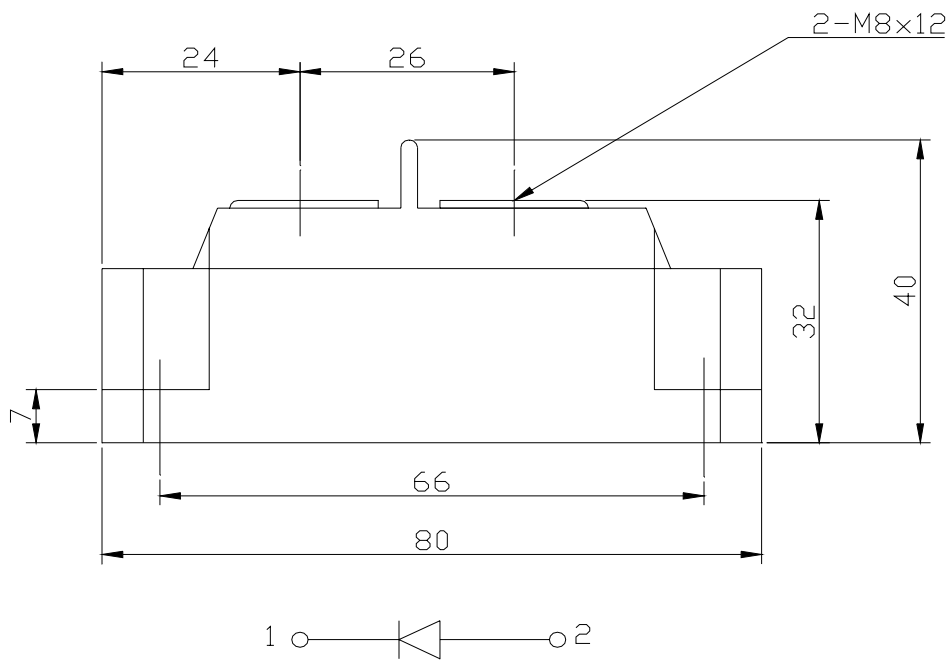
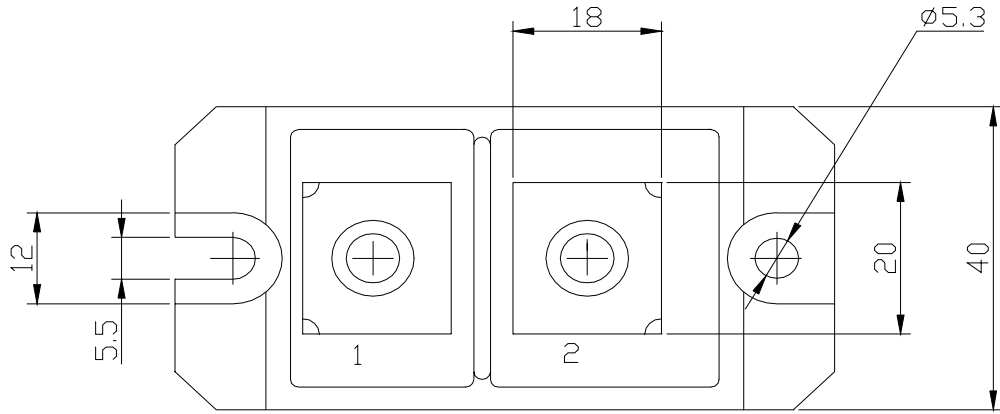

順電圧特性
FORWARD CURRENT VS. VOLTAGE

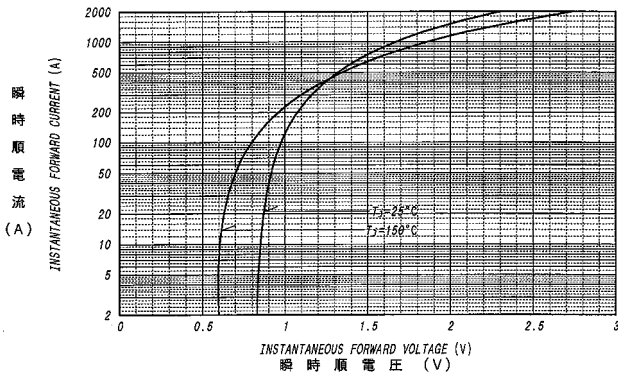

平均順電力損失特性
AVERAGE FORWARD POWER DISSIPATION

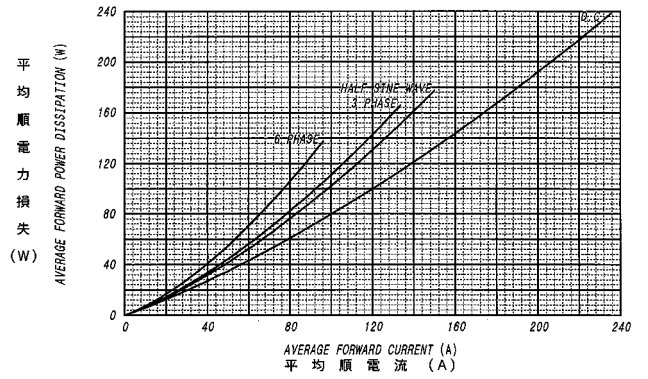

平均順電流 - ケース温度定格
AVERAGE FORWARD CURRENT VS. CASE TEMPERATURE

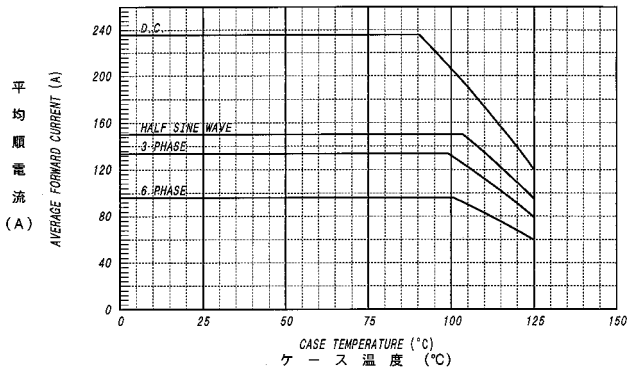

サージ順電流定格
SURGE CURRENT RATINGS

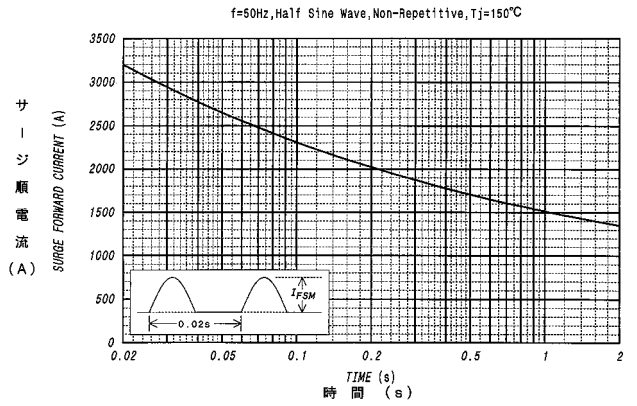

過渡熱抵抗特性
MAXIMUM TRANSIENT THERMAL IMPEDANCE
Junction to Case

