

IGBT Modules

Sixpack

 NPT³ IGBT

$$I_{C80} = 350 \text{ A}$$

$$V_{CES} = 1700 \text{ V}$$

$$V_{CE(sat) \text{ typ.}} = 2.3 \text{ V}$$

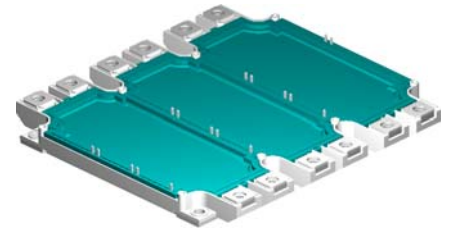
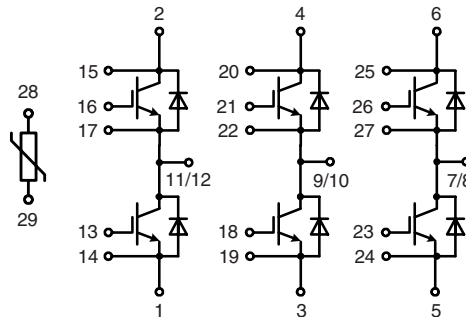

IGBTs

Symbol	Conditions	Maximum Ratings	
V_{CES}	$T_{VJ} = 25^{\circ}\text{C}$ to 125°C	1700	V
V_{GES}		± 20	V
I_{C25}	$T_C = 25^{\circ}\text{C}$	500	A
I_{C80}	$T_C = 80^{\circ}\text{C}$	350	A
RBSOA	$R_G = 3.3 \Omega$; $T_{VJ} = 125^{\circ}\text{C}$ Clamped inductive load; $L = 100 \mu\text{H}$	$I_{CM} = 700$ $V_{CEK} \leq V_{CES}$	A
t_{SC} (SCSOA)	$V_{CE} = 1200 \text{ V}$; $V_{GE} = \pm 15 \text{ V}$; $R_G = 3.3 \Omega$; $T_{VJ} = 125^{\circ}\text{C}$; non-repetitive; $V_{CEmax} \leq V_{CES}$	10	μs
P_{tot}	$T_C = 25^{\circ}\text{C}$	2.2	kW

Features

- NPT³ IGBT technology
- low saturation voltage
- low switching losses
- square RBSOA, no latch up
- high short circuit capability
- positive temperature coefficient for easy paralleling
- MOS input, voltage controlled
- ultra fast free wheeling diodes
- solderable pins for PCB mounting
- package with copper base plate

Advantages

- space savings
- reduced protection circuits
- package designed for wave soldering

Typical Applications

- AC motor control
- AC servo and robot drives
- power supplies

Symbol	Conditions	Characteristic Values ($T_{VJ} = 25^{\circ}\text{C}$, unless otherwise specified)			
		min.	typ.	max.	
$V_{CE(sat)}$	$I_C = 300 \text{ A}$; $V_{GE} = 15 \text{ V}$; $T_{VJ} = 25^{\circ}\text{C}$ $T_{VJ} = 125^{\circ}\text{C}$		2.3 2.7	V V	
$V_{GE(th)}$	$I_C = 30 \text{ mA}$; $V_{GE} = V_{CE}$	4.5		6.5 V	
I_{CES}	$V_{CE} = V_{CES}$; $V_{GE} = 0 \text{ V}$; $T_{VJ} = 25^{\circ}\text{C}$ $T_{VJ} = 125^{\circ}\text{C}$		0.5 7	1 mA 22 mA	
I_{GES}	$V_{CE} = 0 \text{ V}$; $V_{GE} = \pm 20 \text{ V}$			1.5 μA	
$t_{d(on)}$ t_r $t_{d(off)}$ t_f E_{on} E_{off}	Inductive load, $T_{VJ} = 125^{\circ}\text{C}$ $V_{CE} = 900 \text{ V}$; $I_C = 300 \text{ A}$ $V_{GE} = \pm 15 \text{ V}$; $R_G = 3.3 \Omega$		180 110 500 110 100 80	ns ns ns ns mJ mJ	
C_{ies}		$V_{CE} = 25 \text{ V}$; $V_{GE} = 0 \text{ V}$; $f = 1 \text{ MHz}$		33	nF
Q_{Gon}		$V_{CE} = 900 \text{ V}$; $V_{GE} = 15 \text{ V}$; $I_C = 300 \text{ A}$		2.6	μC
R_{thJC}					0.057 K/W

IXYS reserves the right to change limits, test conditions and dimensions.

Diodes

Symbol	Conditions	Maximum Ratings	
I_{F80}	$T_C = 80^\circ\text{C}$	290	A
I_{FRM}	$t_p = 1 \text{ ms}$	570	A

Symbol	Conditions	Characteristic Values		
		min.	typ.	max.
V_F	$I_F = 300 \text{ A}; V_{GE} = 0 \text{ V}; T_{VJ} = 25^\circ\text{C}$			2.3 V
I_{RM}	$I_F = 300 \text{ A}; di_F/dt = 2400 \text{ A}/\mu\text{s}; T_{VJ} = 125^\circ\text{C}; V_R = 1200 \text{ V}$		240	A
R_{thJC}		0.11		K/W

Temperature Sensor NTC

Symbol	Conditions	Characteristic Values		
		min.	typ.	max.
R_{25} $B_{25/50}$	$T = 25^\circ\text{C}$	4.75	5.0 3375	5.25 kΩ K

Module

Symbol	Conditions	Maximum Ratings	
T_{VJ}	operating	-40...+125	°C
T_{JM}		+150	°C
T_{stg}		-40...+125	°C
V_{ISOL}	$I_{ISOL} \leq 1 \text{ mA}; 50/60 \text{ Hz}$	3400	V~
M_d	Mounting torque (M5) Terminal connection torque (M6)	3 - 6 3 - 6	Nm Nm

Symbol	Conditions	Characteristic Values		
		min.	typ.	max.
$R_{term-chip}^{*)}$	Resistance terminal to chip		0.55	mΩ
d_S	Creepage distance on surface	12.7		mm
d_A	Strike distance in air	10		mm
R_{thCH}	with heatsink compound		0.01	K/W
Weight			900	g

*) $V = V_{CE(sat)} + 2x R_{term-chip} \cdot I_C$ resp. $V = V_F + 2x R_{term-chip} \cdot I_F$

Dimensions in mm (1 mm = 0.0394")

