

TOSHIBA INTELLIGENT POWER MODULE

M I G 3 0 J 5 0 1 L**FEATURES**

- (1) Maximum Rating
V_{CES} = 600 V, I_C = 30 A
- (2) Control IC
 - High voltage IC × 3 + low voltage IC × 1
 - 5-V system CMOS/correspond to TTL
 - Single power supply driving bootstrap circuit
- (3) Functions
 - Over current protection: only low-side arm
 - Short circuit protection: high and low-side arms
 - RTC: high and low-side arms
 - Over temperature protection: only low-side arm
 - Power supply under voltage protection: high and low-side arms
 - Fault signal output: In case of abnormal status of low-side arm
- (4) Applications
 - Inverter air conditioners
 - PWM Carrier Frequency 3 kHz

Equivalent Circuit

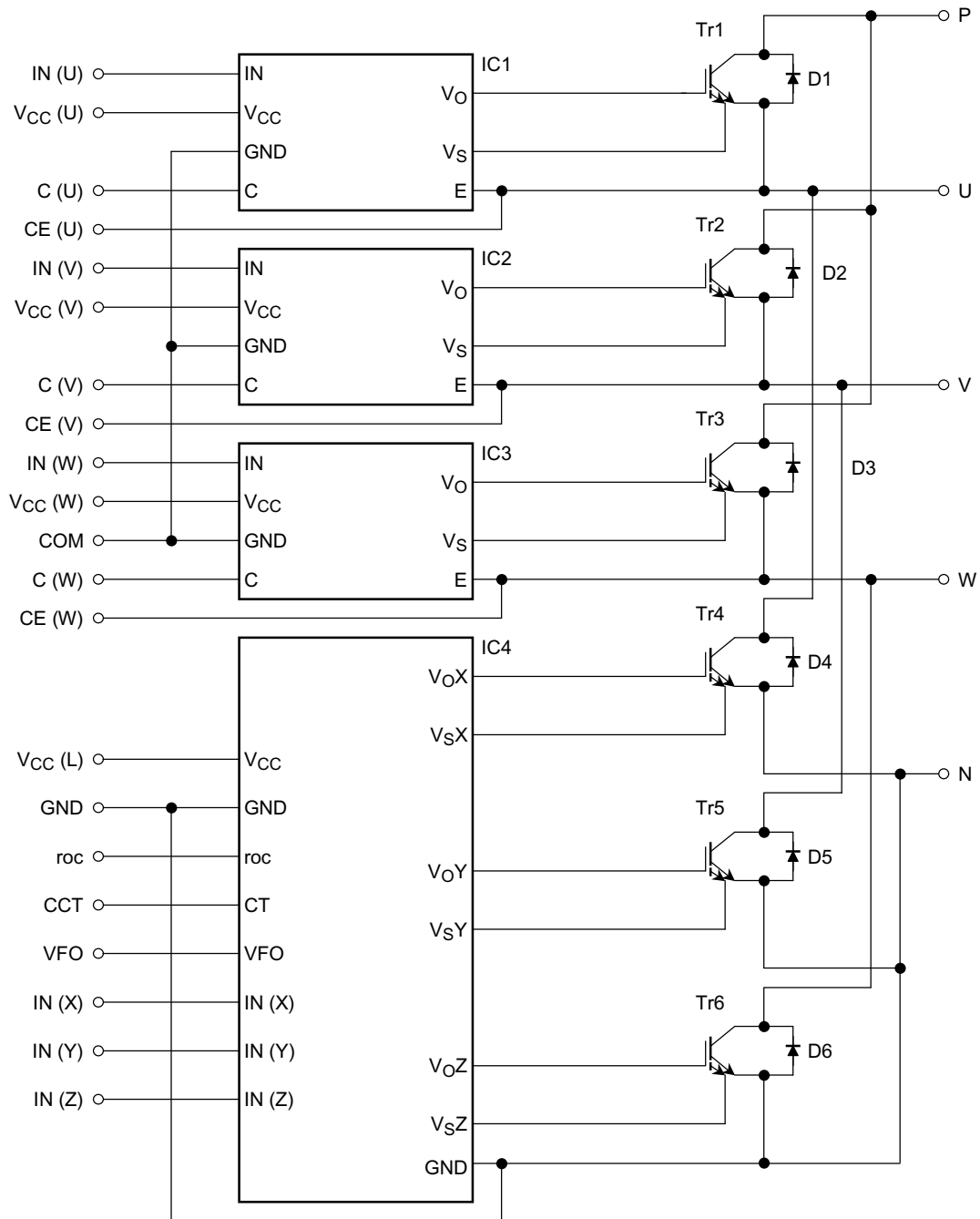

Maximum Ratings (Unless otherwise specified, $T_j = 25^\circ\text{C}$)

Inverter

Item	Symbol	Test Condition	Rating	Unit
Supply Voltage	V_{CC}	P-N	450	V
Supply Voltage (Surge)	V_{CC} (surge)	P-N	500	V
Collector Emitter Voltage	V_{CES}	—	600	V
Collector Current	$\pm I_C$	$T_c = 25^\circ\text{C}$	30	A
Collector Current (Peak)	$\pm I_{CP}$	$T_c = 25^\circ\text{C}$	60	A
Collector Power Dissipation	P_C	$T_c = 25^\circ\text{C}$	50	W
Junction Temperature	T_j	—	150	$^\circ\text{C}$

Control (protection)

Item	Symbol	Test Condition	Rating	Unit
Supply Voltage	V_D	V_{CC} (U), (V), (W) – COM, V_{CC} (L) – GND	20	V
Supply Voltage	V_{DB}	C (U), (V), (W) – CE (U), (V), (W)	20	V
Input Voltage	V_{IN}	IN (U), (V), (W) – COM, IN (X), (Y), (Z) – GND	-0.5 to $V_D + 0.5$	V
Fault Output Voltage	V_{FO}	VFO – GND	-0.5 to $V_D + 0.5$	V
Fault Output Current	I_{FO}	Sink current rating of VFO	10	mA
Overcurrent Protection Set-up Terminal	I_{roc}	roc – GND	3	mA

General

Item	Symbol	Test Condition	Rating	Unit
Power Supply Voltage Self-protection Range (Short)	V_{CC} (PROT)	$V_D = 13.5\text{ V to }16.5\text{ V}$ Inverter: $T_j = 125^\circ\text{C}$	400	V
Operating Module Frame Temperature	T_c	—	-20 to +100	$^\circ\text{C}$
Storage Temperature	T_{stg}	—	-40 to +125	$^\circ\text{C}$
Isolation Voltage	V_{ISO}	Sine wave 60 Hz, AC 1 minute, Fin-terminal	2500	V_{rms}

Thermal resistance

Item	Symbol	Test Condition	Min	Typ.	Max	Unit
Junction to Case Thermal Resistance	$R_{th(j-c)}$	Inverter IGBT	—	—	2.5	$^\circ\text{C/W}$
	$R_{th(j-c)}$	Inverter FRD	—	—	4.5	
Case to Fin Thermal Resistance	$R_{th(c-f)}$	Case-Fin (coating grease)	—	—	0.4	

Electrical Characteristics (Unless otherwise specified, $T_j = 25^\circ\text{C}$)

Inverter

Item	Symbol	Test Condition		Min	Typ.	Max	Unit
Collector-Emitter Saturation Voltage	$V_{CE(sat)}$	$V_D = V_{DB} = 15\text{ V}$ Input = ON	$I_C = 30\text{ A}, T_j = 25^\circ\text{C}$	1.4	1.8	2.3	V
			$I_C = 30\text{ A}, T_j = 125^\circ\text{C}$	1.5	—	3.0	
Forward Voltage	V_F	$I_F = 30\text{ A}, \text{Input} = \text{OFF}$		1.5	2.2	2.9	V
Switching Time	$t_{on(H)}$	$V_{CC} = 300\text{ V}, V_D = 15\text{ V}, I_C = 30\text{ A}$ Inductance load (high and low-side arms) Input = ON (NOTE 1)		—	4.5	5.5	μs
	$t_{on(L)}$			—	4.0	5.5	
	t_{rr}			—	0.1	—	
	$t_c(\text{on})$			—	1.1	1.5	
	$t_{off(H)}$			—	3.2	4.5	
	$t_{off(L)}$			—	1.1	2.2	
	$t_c(\text{off})$			—	0.5	1.0	
Collector Cut-off Current	I_{CES}	$V_{CE} = 600\text{ V}$	$T_j = 25^\circ\text{C}$	—	—	1.0	mA
			$T_j = 125^\circ\text{C}$	—	—	10	

Control (protection)

Item	Symbol	Test Condition		Min	Typ.	Max	Unit		
Control Power Supply Voltage	V_D	$V_{CC(U), (V), (W)} - \text{COM},$ $V_{CC(L)} - \text{GND}$		13.5	15.0	16.5	V		
Circuit Current	I_D	$V_D = 15\text{ V},$ Input = OFF $V_{DB} = 15\text{ V},$ Input = OFF	$V_{CC(L)} - \text{GND}$	—	14	—	mA		
			$C(U) - CE(U),$ $C(V) - CE(V),$ $C(W) - CE(W)$	—	1.5	—			
Fault Output Voltage	V_{FOH}	$R_{oc} = 1.54\text{ k}\Omega, V_D = 15\text{ V},$ $FO = 10\text{ k}\Omega \quad 5\text{ V pullup}$		4.9	—	—	V		
	$V_{FOL(1)}$	$R_{oc} = 1.55\text{ k}\Omega, I_{FO} = 5\text{ mA}, V_D = 10\text{ V}$		—	1.2	1.8	V		
	$V_{FOL(2)}$	$FO = 10\text{ k}\Omega \quad 5\text{ V pullup}$ $V_D = 15\text{ V}$		—	0.8	1.0	V		
High-and Low-Side Arm Dead Time	t_{dead}	Correspond to each arm input $V_D = 15\text{ V}$ $-20 \leq T_j \leq 100^\circ\text{C}$		10	—	—	μs		
Over Current Protection Trip Level	I_{OC}	$V_D = 15\text{ V}, R_{oc} = 1.54\text{ k}\Omega \pm 0.5\%,$ $I_{OC} = 1.86\text{ k} \times \text{current (rating)} (30\text{ A})$ /Roc (Note 1)		30	36	42	A		
Control Power Supply Under Voltage Protection	UV_{DBH}	$T_j \leq 125^\circ\text{C}$ Filtering time min $5\text{ }\mu\text{s}$		Trip level		10.0	10.5	11.3	V
	UV_{DBHys}			Hysteresis		0.4	0.55	0.7	V
	UV_{DL}			Trip level		11.5	12.0	12.5	V
	UV_{DLhys}			Hysteresis		0.3	0.5	0.7	V
Over Temperature Protection (T_j) (Note 2)	OT	Trip level $V_D = 15\text{ V}$		—	150	—	$^\circ\text{C}$		
	OT _{hys}	Hysteresis $V_D = 15\text{ V}$		—	7.5	—	$^\circ\text{C}$		
Fault Output Pulse Width	tFO	$V_D = 15\text{ V}, C_{FO} = 22\text{ nF}$ (Note 3)		2.6	4.4	—	ms		
Input ON-Threshold Voltage (H side)	$V_{IN(ON)}$	$IN(U), (V), (W) - \text{COM}$ $V_D = 15\text{ V}$		1.0	—	2.0	V		
Input OFF-Threshold Voltage (H side)	$V_{IN(OFF)}$			2.0	—	3.0			
Input ON-Threshold Voltage (L side)	$V_{IN(ON)}$	$IN(X), (Y), (Z) - \text{GND}$ $V_D = 15\text{ V}$		1.0	—	2.0	V		
Input OFF-Threshold Voltage (L side)	$V_{IN(OFF)}$			2.0	—	3.0			

Note 1: Can set overcurrent protection only at low-side arm.

Note 2: T_j specifies junction temperature for low-side control IC.

Note 3: When low-side arm trips caused by over/short current protection or under voltage protection or over temperature protection, fault pulse outputs.

Pulse width, tFO, can be derived from the following equation:

$$tFO(\text{ms}) = 200 \times \text{external capacitance}(\mu\text{F})$$

Mechanical Test and Characteristics

Item	Symbol	Test Condition	Applicable Standard	Min	Typ.	Max	Unit
Screw Tightening Torque	—	Screws M4	—	10	—	15	kg·cm
		Recommended rating: 12 kg·cm					
Pin Straining Strength	—	Load 4.5 kg/44.1 N (P, N, U, V, W pins)	JIS C7021	30	—	—	s
		Load 1.0 kg/9.8 N (except P, N, U, V, W pins)					
Pin Bending Strength	—	Load 1.5 kg /bend 90° with 14.7 N (P, N, U, V, W pins)	JIS C7021	2	—	—	cycles
		Load 0.5 kg /bend 90° with 4.9 N (except P, N, U, V, W pins)					
Weight	—	—	—	—	52	—	g

Recommended Usage Condition

Item	Symbol	Test Condition	Recommended Rating			Unit
			Min	Typ.	Max	
Power Supply Voltage	V_{CC}	P – N	200	300	400	V
Control Power Supply Voltage	V_D	$V_{CC (U), (V), (W)} - COM,$ $V_{CC (L)} - GND$	13.5	15.0	16.5	V
Control Power Supply Voltage	V_{DB}	C (U), (V), (W) – CE (U), (V), (W)	13.5	15.0	16.5	V
PWM Carrier Frequency	f_c	—	—	3	—	kHz
High and Low-side Arms Dead Time	t_{dead}	Correspond to each arm input	10	—	—	μs
Minimum Input pulse width	t_{min}	Acceptable minimum Input pulse width	7			μs
Input ON-Threshold Voltage	$V_{IN (ON)}$	IN (U), (V), (W) – COM	0 to 0.65			V
Input OFF-Threshold Voltage	$V_{IN (OFF)}$	IN (X), (Y), (Z) – GND	4.0 to 5.5			V

NOTE 1 Switching Waveform

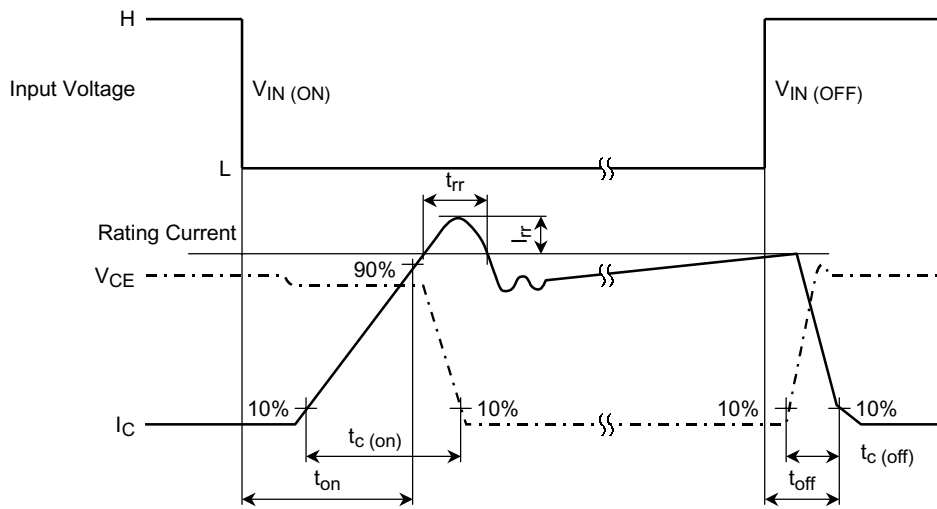

t_{on} (H): high-side arms "t_{on}"
 t_{on} (L): low-side arms "t_{on}"
 t_{off} (H): high-side arms "t_{off}"
 t_{off} (L): low-side arms "t_{off}"

Switching Time Test Circuit of High Side

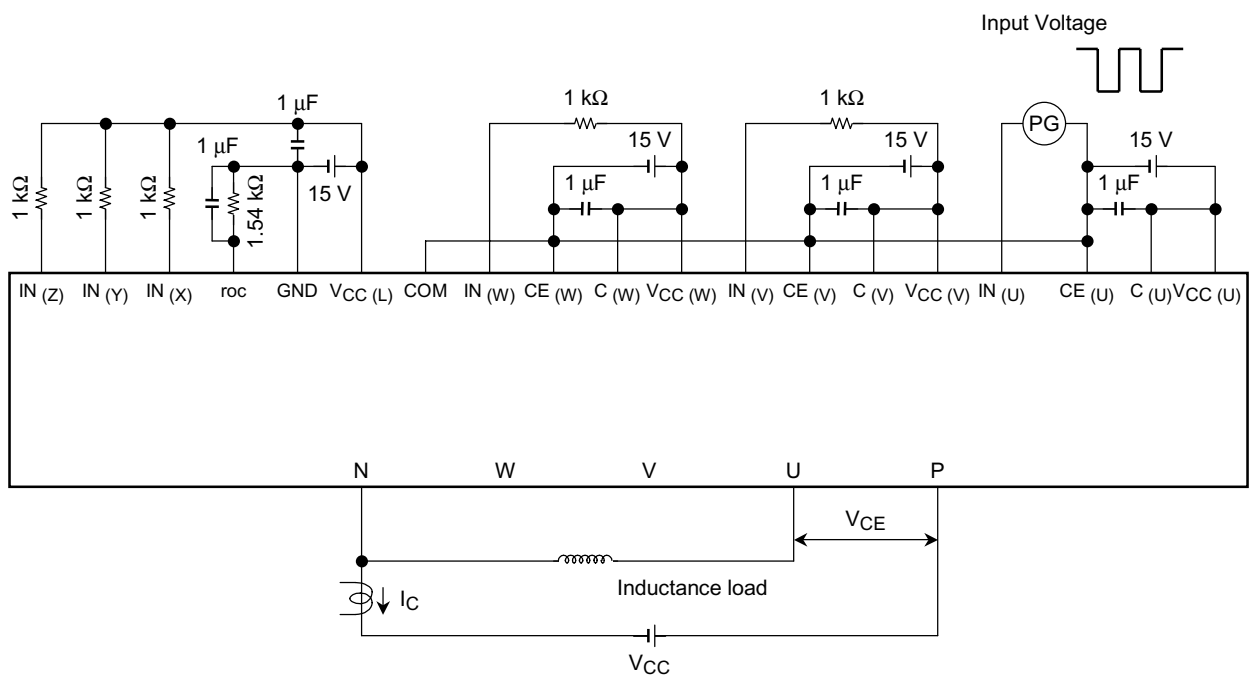

Switching Time Test Circuit of Low Side

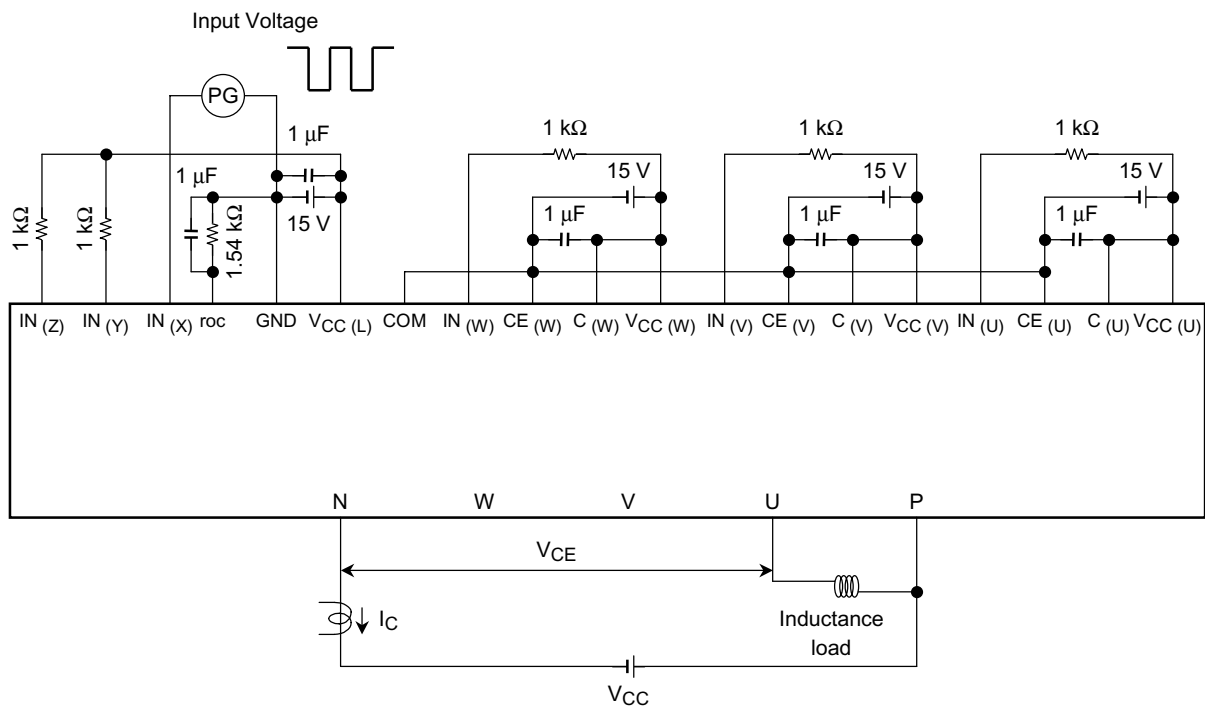

NOTE 2 Details in protection function against overcurrent

- (1) OC (overcurrent) protection
Protection function against overcurrent during the normal operation
This function is set to only a low-side circuit. Diagnosis is also output.
- (2) SC (short-circuit) protection
Protection function against overcurrent during abnormal operation such as a twisted wiring on a circuit board
This function is set to high-and low-side circuits. Diagnosis is also out put.
- (3) RTC (real time control) protection
SC protection circuit has mask time period for about 1.5 μs to protect malfunction against noise. RTC protection is designed to protect IGBT from overcurrent and limit current flow during this mask time period. OC and SC protection functions cut off their operations, but RTC function just control current peak. Diagnosis function is not applied to this protection.

Protection	Arm	Set Up Level	Error Signal
OC	Low Side	120% that of rating	○
	High Side	Non	—
SC	Low Side	180% that of rating	○
	High Side	220% that of rating	Non
RTC	Low Side	400% that of rating	Non
	High Side	400% that of rating	Non

Rroc = 1.54 kΩ

Package Dimension/Pin Assignment

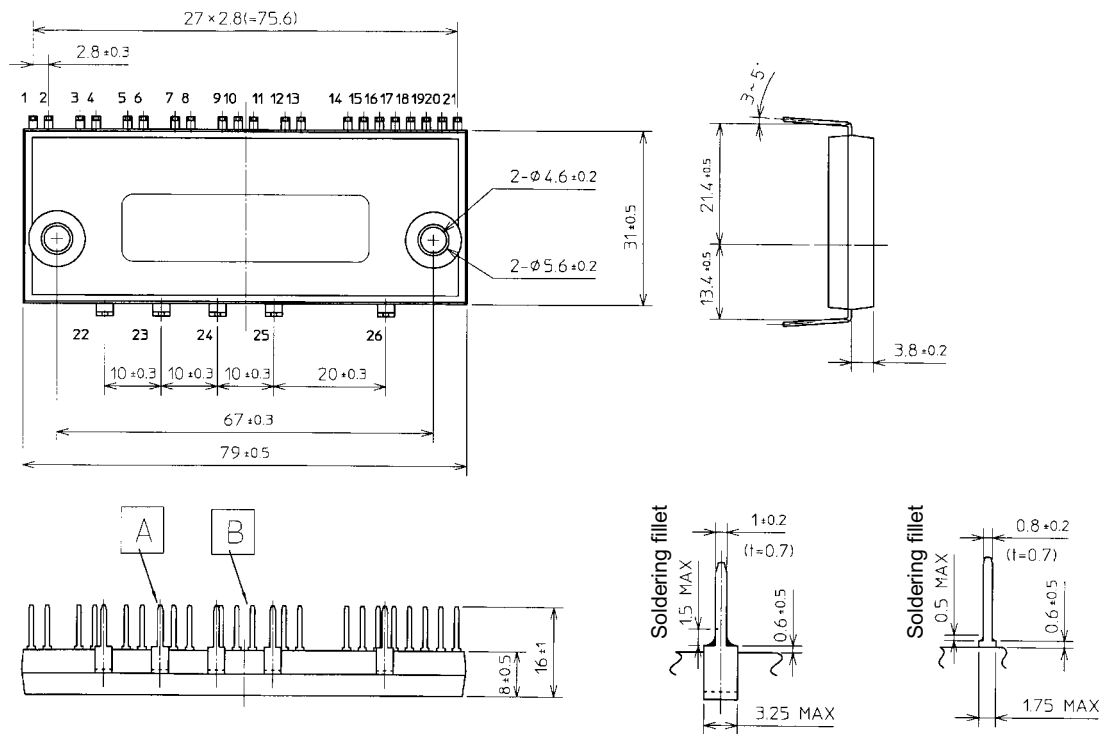

Enlarged part A (5 parts) Enlarged part B (21 parts)

Pin Names

1. IN (U)	14. V _{CC} (L)
2. V _{CC} (U)	15. GND
3. C (U)	16. roc
4. CE (U)	17. CCT
5. IN (V)	18. VFO
6. V _{CC} (V)	19. IN (X)
7. C (V)	20. IN (Y)
8. CE (V)	21. IN (Z)
9. IN (W)	22. P
10. V _{CC} (W)	23. U
11. COM	24. V
12. C (W)	25. W
13. CE (W)	26. N

Timing Charts

Timing Chart for Short Current Protection Sequence (SC)

- (1) Upon occasion of short current condition, at first step, V_{GE} is step-down to one-half of nominal value in order to reduce IGBT saturation current and finally, V_{GE} is completely interrupted after some certain time, t_{off} (OC).
- (2) An error signal output (V_{FO}) goes into 'L' level when the lower arm IGBT is subjected to short current condition. The timing of V_{FO} output ('L' level) is provided at complete interruption of V_{GE} and the 'L' level is maintained during some certain time duration (t_{FO}).
- (3) The reset operation is provided on condition that error signal output return to 'H' level after certain time duration and over current condition is removed and input signal turns from operation "H" to "L".

Timing Chart

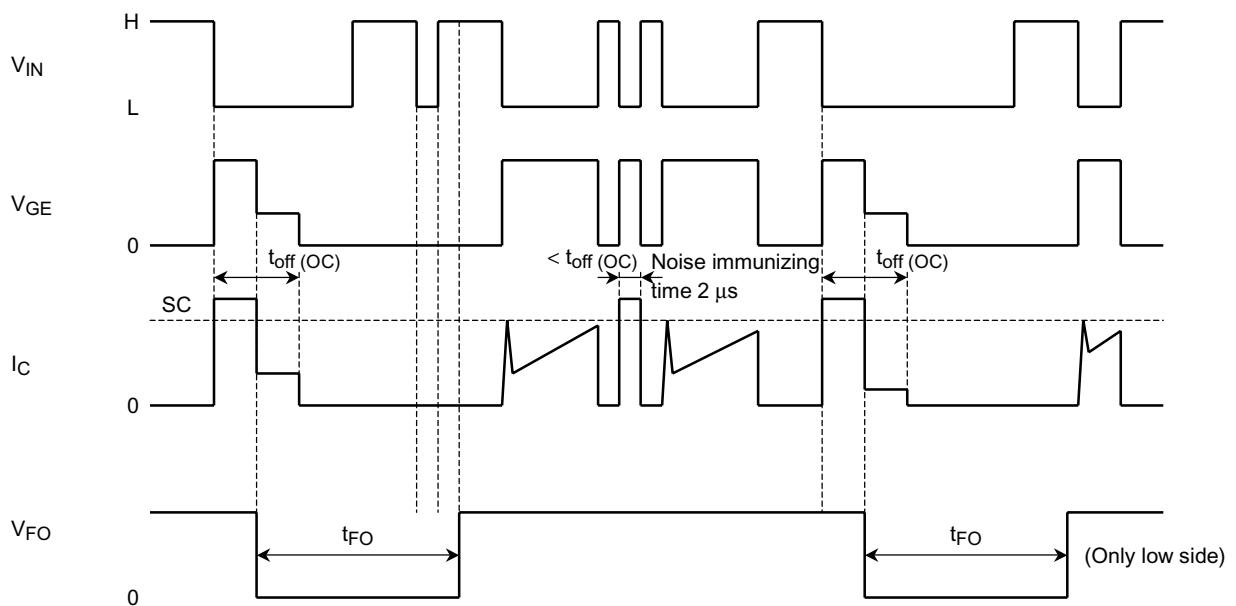

If these IPMs are accidentally shorted to ground and a 3-kHz carrier frequency is applied to them for 50 ms or more, they may be destroyed as a result. If short-circuit protection is enabled for the upper-arm IPMs, no error signal will be output when shorting occurs. Thus, shorting to ground will continue unabated for as long as the signal is input to the upper-arm IPMs from the microcontroller.

Timing Chart for Over Current Protection Sequence (OC) . . . Only low side

- (1) Upon occasion of over current condition, at first step, V_{GE} is step-down to one-half of nominal value in order to reduce IGBT saturation current and finally, V_{GE} is completely interrupted after some certain time, t_{off} (OC).
- (2) An error signal output (V_{FO}) goes into 'L' level when the lower arm IGBT is subjected to over current condition. The timing of V_{FO} output ('L' level) is provided at complete interruption of V_{GE} and the 'L' level is maintained during some certain time duration (t_{FO}).
- (3) The reset operation is provided on condition that error signal output return to 'H' level after certain time duration and over current condition is removed and input signal turns from operation "H" to "L".

Timing Chart

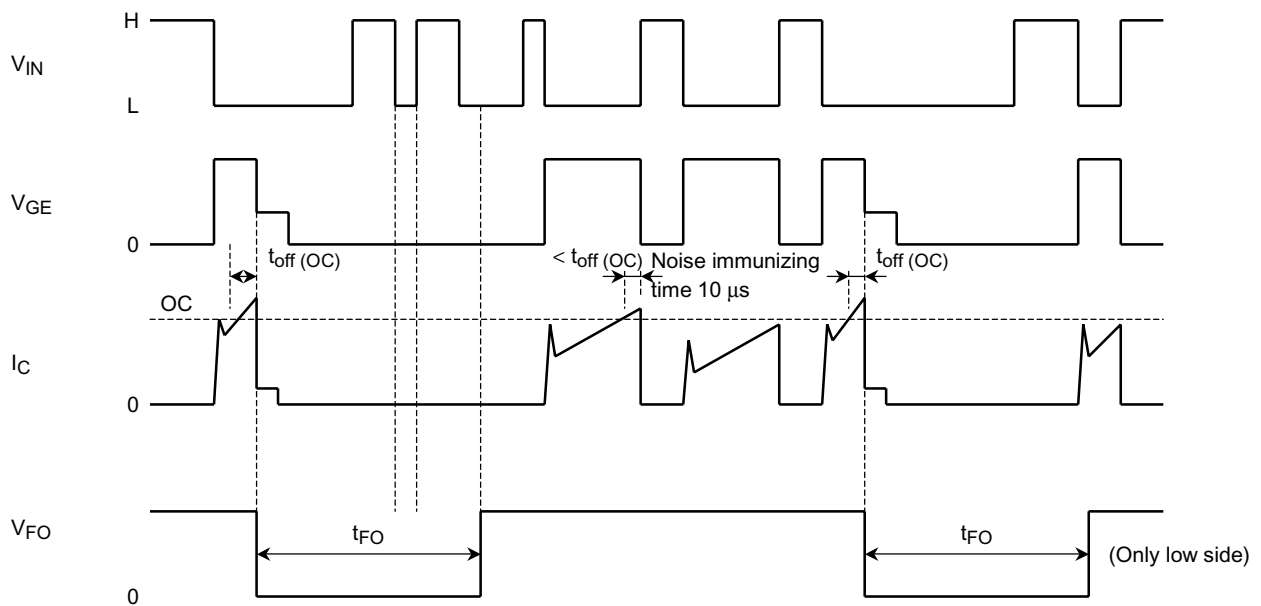

Timing Chart for Control Power Supply Under Voltage Protection Sequence (UV)

- (1) Upon occasion of control power supply under voltage, gate voltage (V_{GE}) is interrupted and IGBT moves into 'off-stage'.
(This condition continues between UV Trip Level and UV Reset Level as shown in the chart)
- (2) An error signal output (V_{FO}) stays in 'L' level until the power supply voltage returns to the reset level after the voltage reaches to the trip level.
- (3) The reset operation is provided on condition that power supply voltage returns to the UV reset level and input signal turns from operation "H" to "L".

Timing Chart

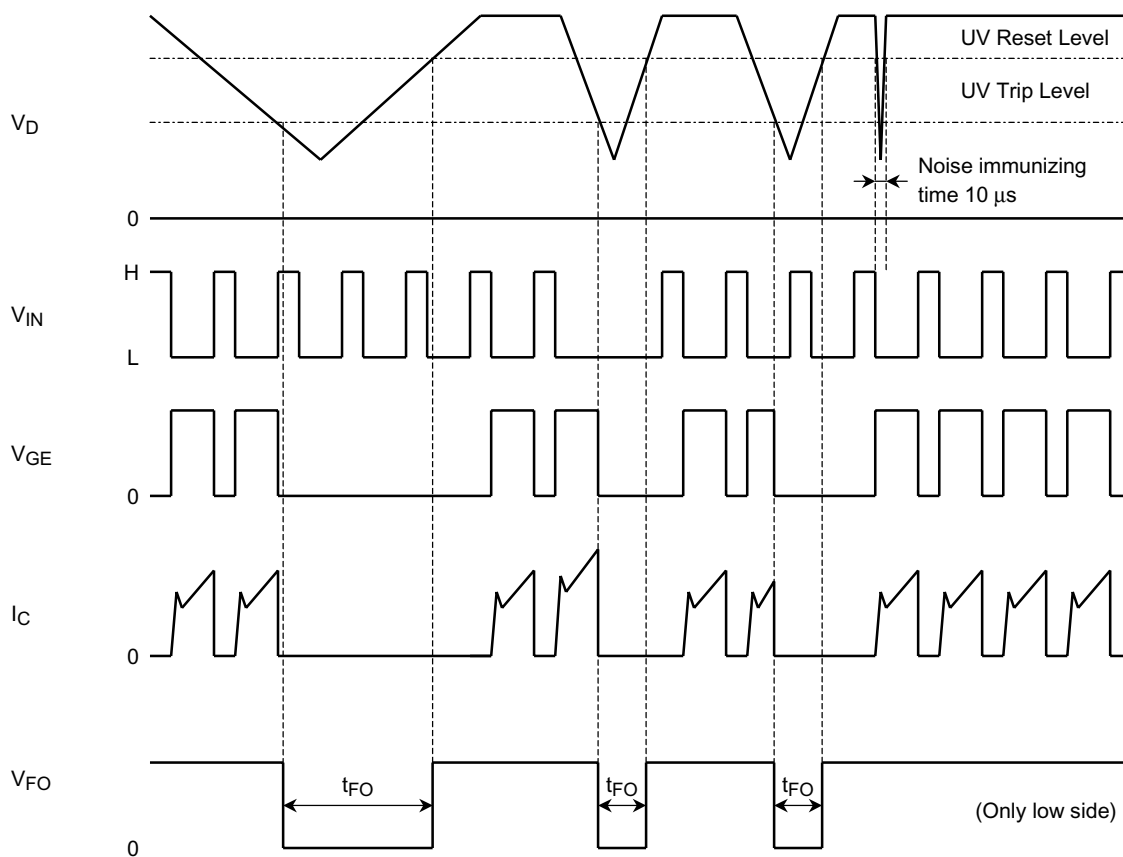

Timing Chart for Over Temperature Protection Sequence (OT)

- (1) Using temperature dependent characteristics of diode on low side control IC, the junction temperature (T_c) is detected. Upon occasion of over temperature condition, V_{GE} of the lower arm IGBT is interrupted.
(This condition continues between OT Trip Level and OT Reset Level as shown in the chart)
- (2) An error signal output (V_{FO}) stays in 'L' level until the case temperature goes below the reset level after the temperature reaches to the trip level. (Only low side arm faults are output)
- (3) The reset operation is provided on condition that case temperature goes below the OT reset level and input signal turns from operation "H" to "L".

Timing Chart

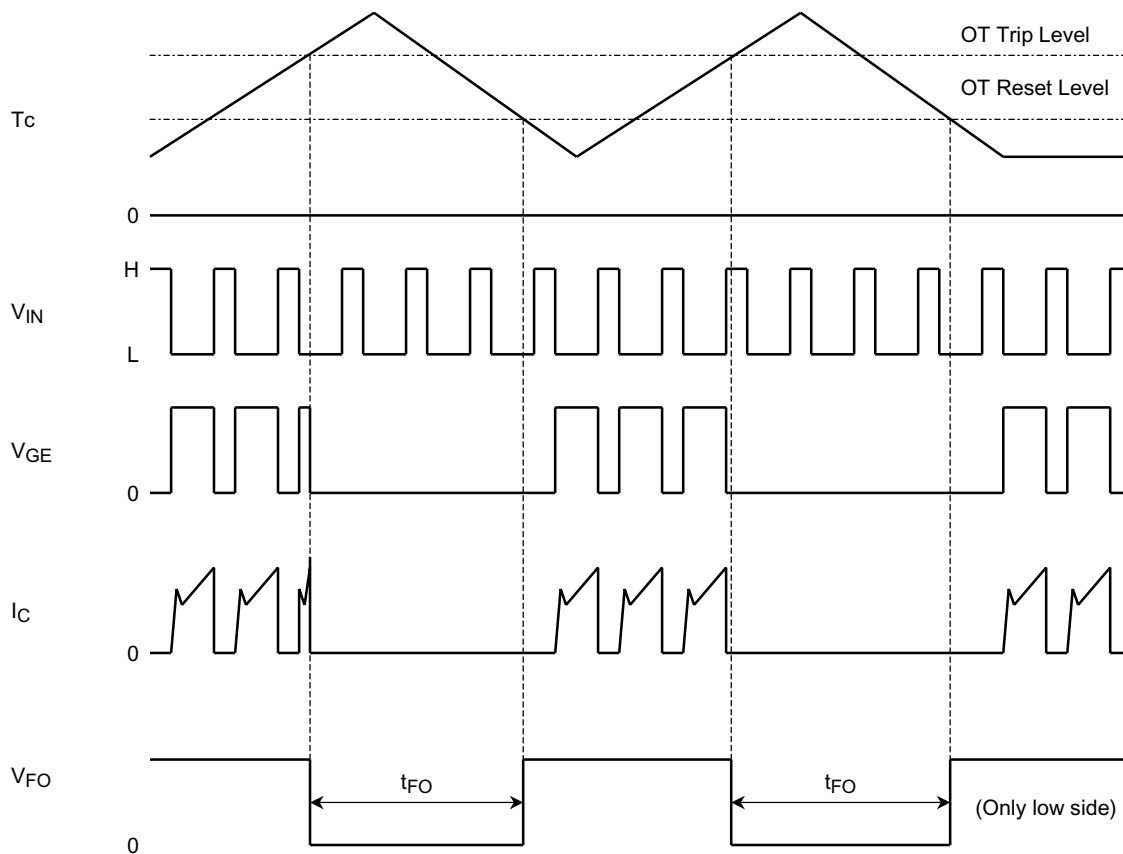

Inverter System

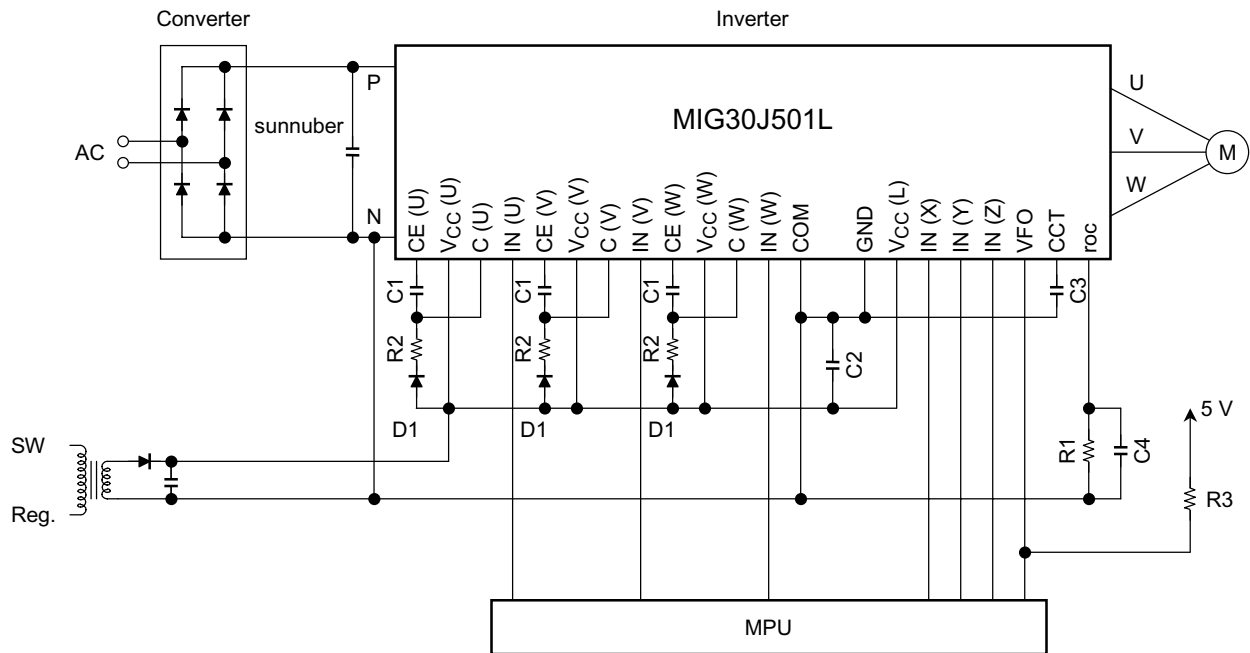

Recommended Usage Parts

- C1: 10 μ F (Bootstrap capacitor necessary to connect current limiting resistance.)
- C2: 1 μ F + 0.01 μ F (Power supply bybass capacitor)
- C3: 0.068 μ F (For pulse width of error signal. $tF_o = C3 (\mu F) \times 200 \text{ ms}$)
- C4: 1 μ F + 0.01 μ F (Noise filter for Fixed resistor of overcurrent protection.)
- R1: 1.54 $k\Omega \pm 0.5\%$ (Fixed resistor of overcurrent protection. $OC = \text{Rating Current} \times (1860/R1)$)
- R2: 51 Ω (Current limit resistance of bootstrap diode. Value depends upon system.)
- R3: 3.3 $k\Omega$ (Pull-up resistor of fault output pin.)
- D1: 600 V/1 A (High speed diode for bootstrap. Recommend: 1JU42.)

Please optimize sunnuber circuit between PN junction according to your using system.

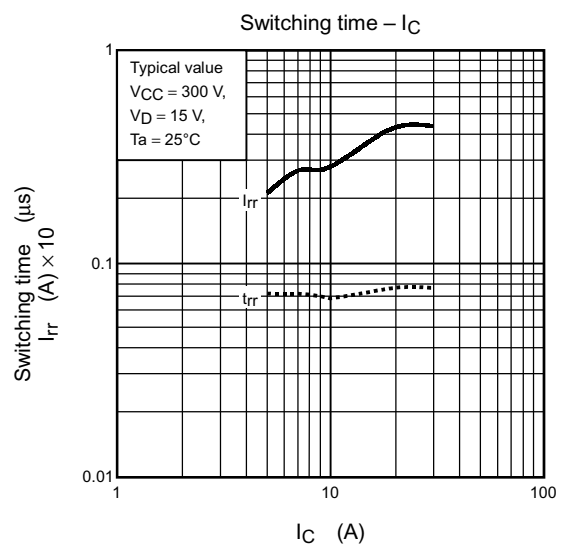
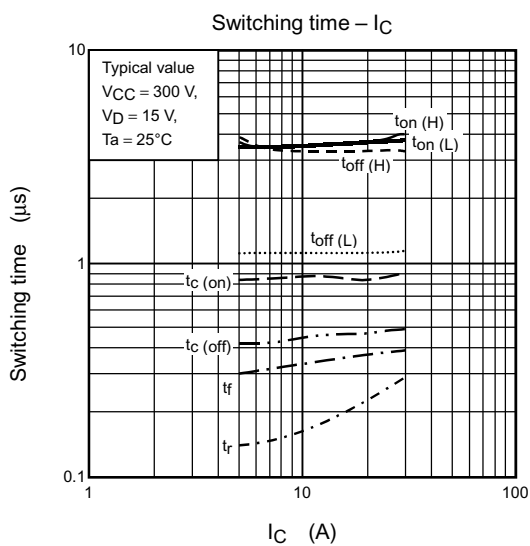
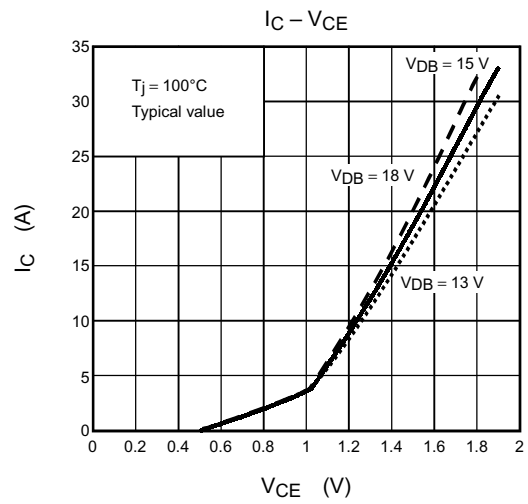
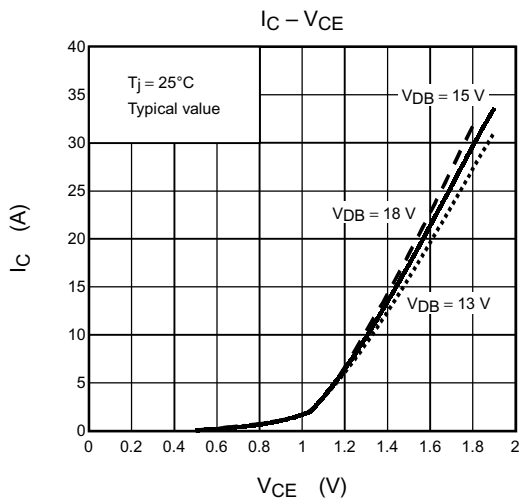
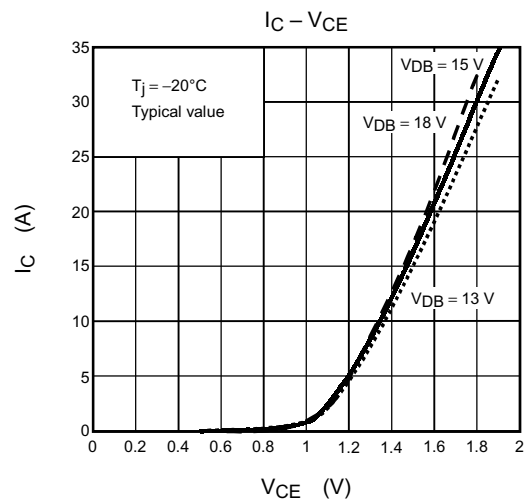
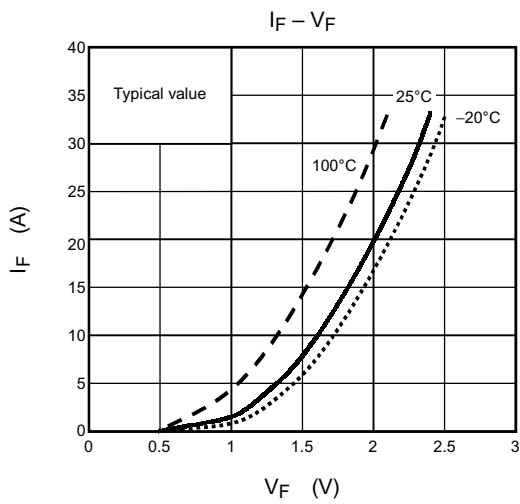

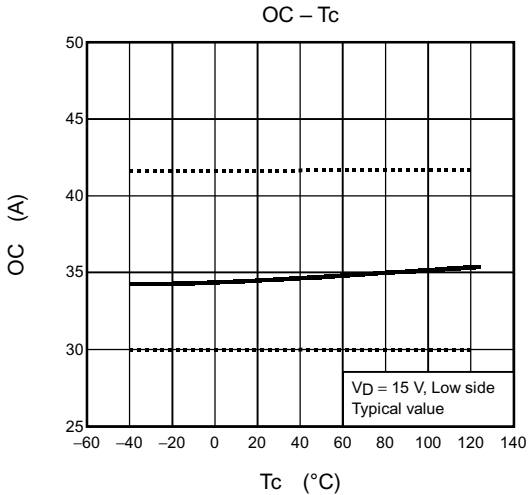

IC internal circuit for IGBT driver

1. Input

High-side arm

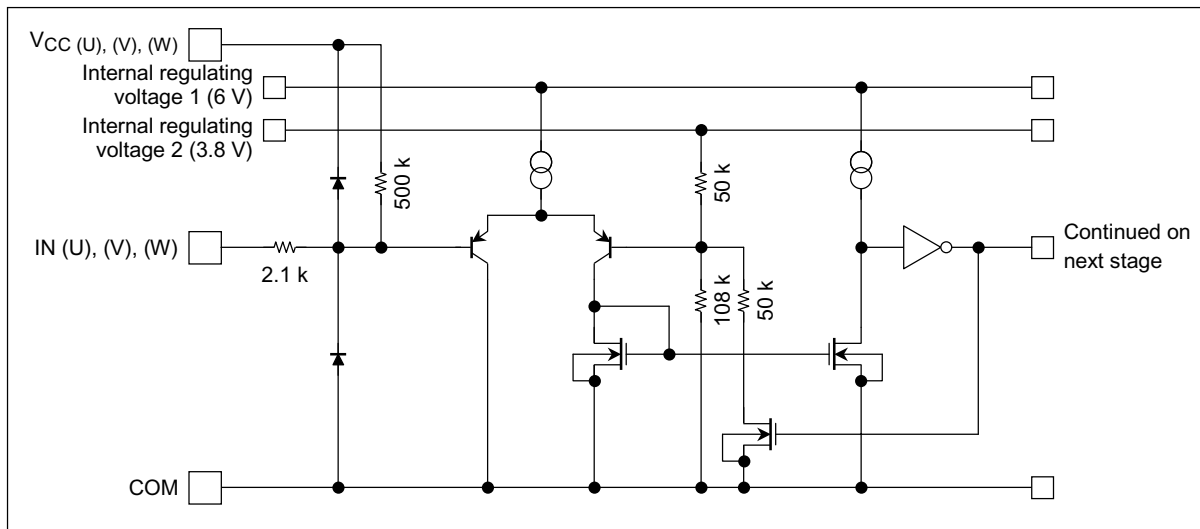

Low-side arm

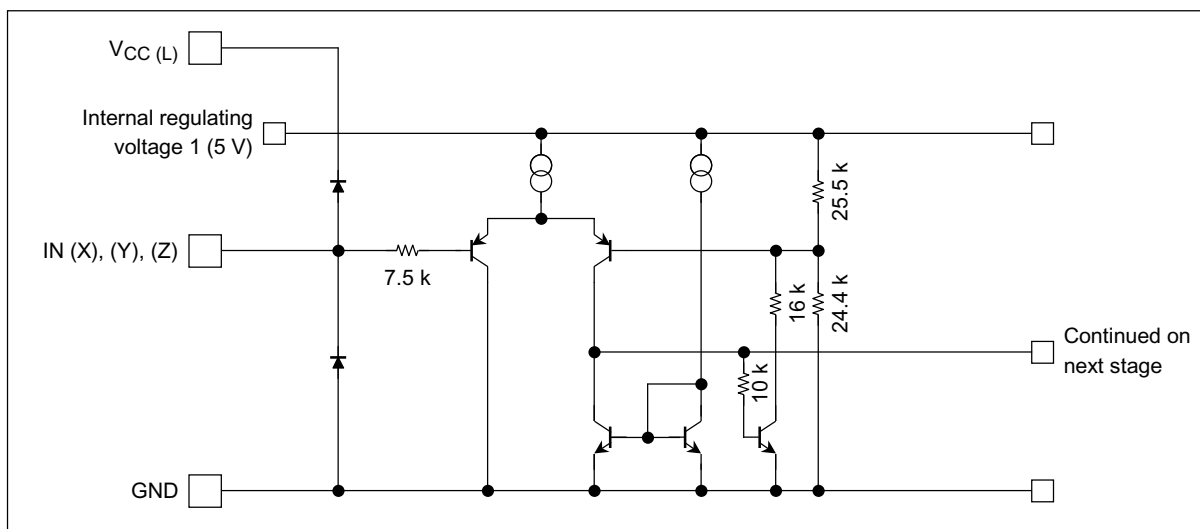

2. roc

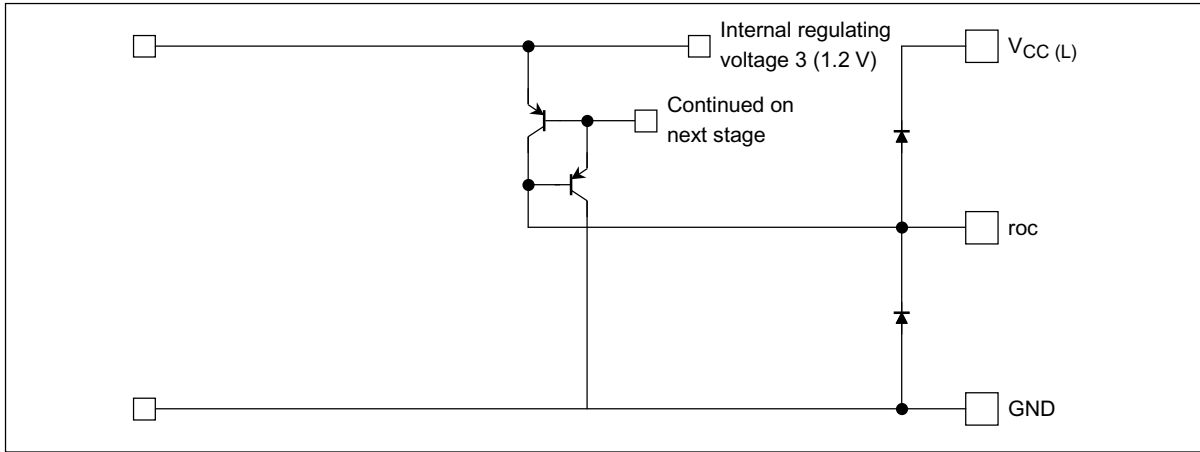

3. CCT

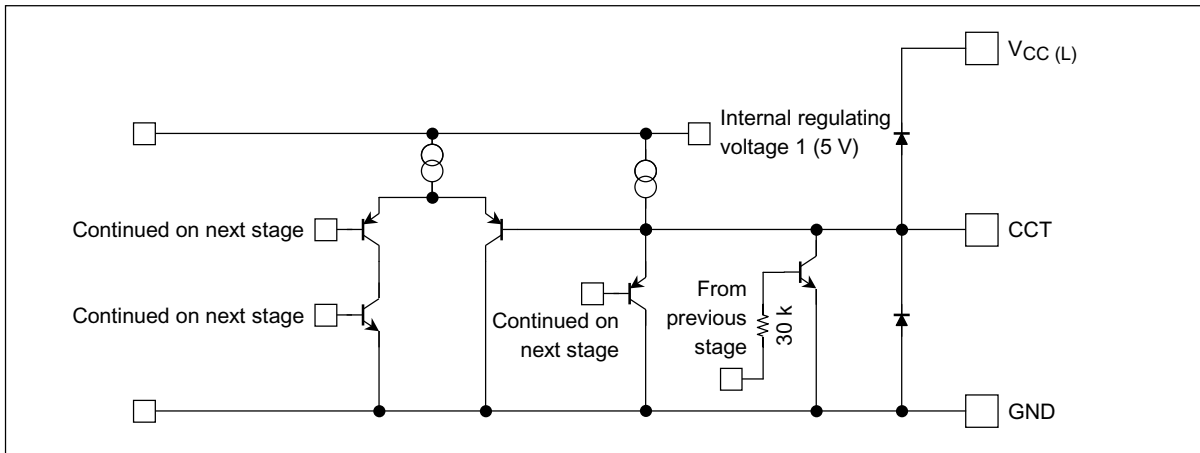

4. VFO

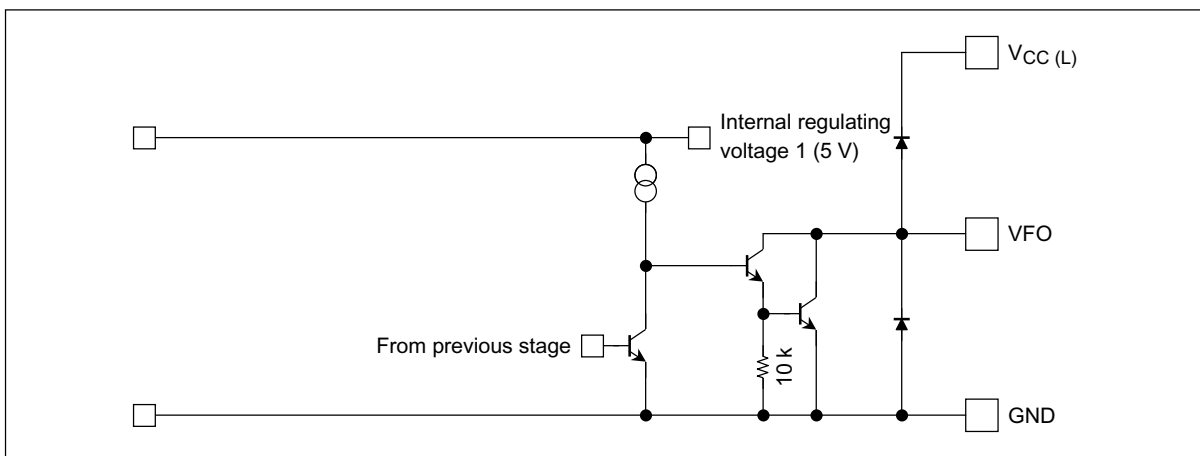

Recommended circuit example when using a photocoupler

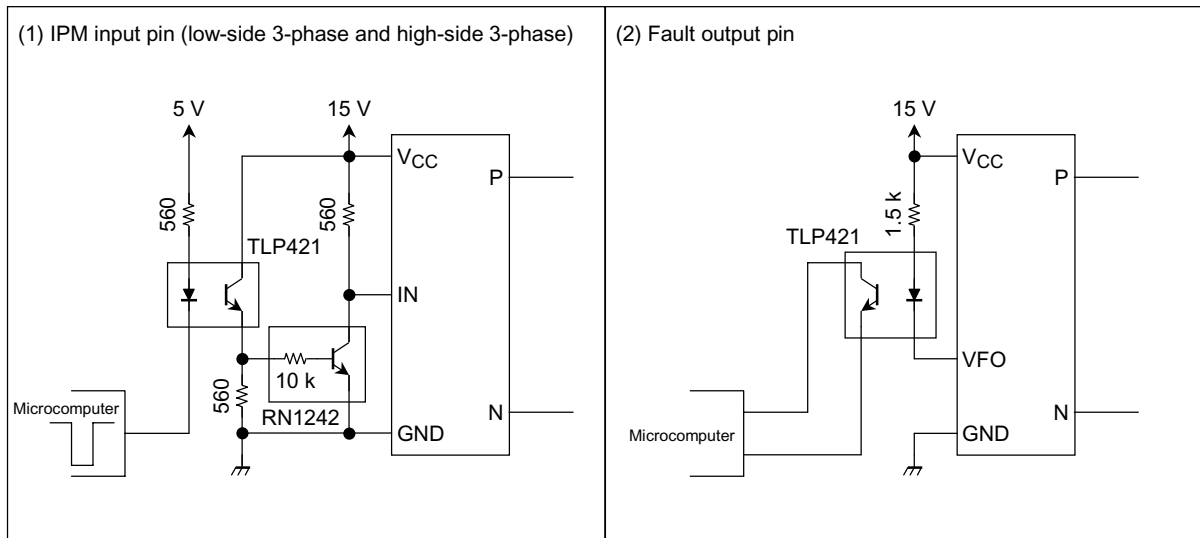

Marking

TOSHIBA □□←Lot no.

MIG30J501L JAPAN

Precautions on Electrostatic Electricity

- (1) Operators must wear anti-static clothing and conductive shoes (or a leg or heel strap).
- (2) Operators must wear a wrist strap grounded to earth via a resistor of about 1 M Ω .
- (3) Soldering irons must be grounded from iron tip to earth, and must be used only at low voltages.
- (4) If the tweezers you use are likely to touch the device terminals, use anti-static tweezers and in particular avoid metallic tweezers. If a charged device touches a low-resistance tool, rapid discharge can occur. When using vacuum tweezers, attach a conductive chucking pat to the tip, and connect it to a dedicated ground used especially for anti-static purposes (suggested resistance value: 10⁴ to 10⁸ Ω).
- (5) Do not place devices or their containers near sources of strong electrical fields (such as above a CRT).
- (6) When storing printed circuit boards which have devices mounted on them, use a board container or bag that is protected against static charge. To avoid the occurrence of static charge or discharge due to friction, keep the boards separate from one other and do not stack them directly on top of one another.
- (7) Ensure, if possible, that any articles (such as clipboards) which are brought to any location where the level of static electricity must be closely controlled are constructed of anti-static materials.
- (8) In cases where the human body comes into direct contact with a device, be sure to wear anti-static finger covers or gloves (suggested resistance value: 10⁸ Ω or less).
- (9) Equipment safety covers installed near devices should have resistance ratings of 10⁹ Ω or less.
- (10) If a wrist strap cannot be used for some reason, and there is a possibility of imparting friction to devices, use an ionizer.

RESTRICTIONS ON PRODUCT USE

000707EBA

- TOSHIBA is continually working to improve the quality and reliability of its products. Nevertheless, semiconductor devices in general can malfunction or fail due to their inherent electrical sensitivity and vulnerability to physical stress. It is the responsibility of the buyer, when utilizing TOSHIBA products, to comply with the standards of safety in making a safe design for the entire system, and to avoid situations in which a malfunction or failure of such TOSHIBA products could cause loss of human life, bodily injury or damage to property.
In developing your designs, please ensure that TOSHIBA products are used within specified operating ranges as set forth in the most recent TOSHIBA products specifications. Also, please keep in mind the precautions and conditions set forth in the "Handling Guide for Semiconductor Devices," or "TOSHIBA Semiconductor Reliability Handbook" etc..
- The TOSHIBA products listed in this document are intended for usage in general electronics applications (computer, personal equipment, office equipment, measuring equipment, industrial robotics, domestic appliances, etc.). These TOSHIBA products are neither intended nor warranted for usage in equipment that requires extraordinarily high quality and/or reliability or a malfunction or failure of which may cause loss of human life or bodily injury ("Unintended Usage"). Unintended Usage include atomic energy control instruments, airplane or spaceship instruments, transportation instruments, traffic signal instruments, combustion control instruments, medical instruments, all types of safety devices, etc.. Unintended Usage of TOSHIBA products listed in this document shall be made at the customer's own risk.
- The products described in this document are subject to the foreign exchange and foreign trade laws.
- The information contained herein is presented only as a guide for the applications of our products. No responsibility is assumed by TOSHIBA CORPORATION for any infringements of intellectual property or other rights of the third parties which may result from its use. No license is granted by implication or otherwise under any intellectual property or other rights of TOSHIBA CORPORATION or others.
- The information contained herein is subject to change without notice.