

MITSUBISHI SEMICONDUCTOR <Intelligent Power Module>

# MIG100J7CSB1W (600V/100A 7in1)

High Power Switching Applications

Motor Control Applications

- Integrates inverter, brake power circuit and control circuits (IGBT drive units, and units for protection against short-circuit current, overcurrent, undervoltage and overtemperature) into a single package.
- The electrodes are isolated from the case
- Low thermal resistance
- $V_{CE(sat)} = 1.9\text{ V (typ.)}$
- UL recognized: File No.E87989
- Weight: 278 g (typ.)

## Equivalent Circuit

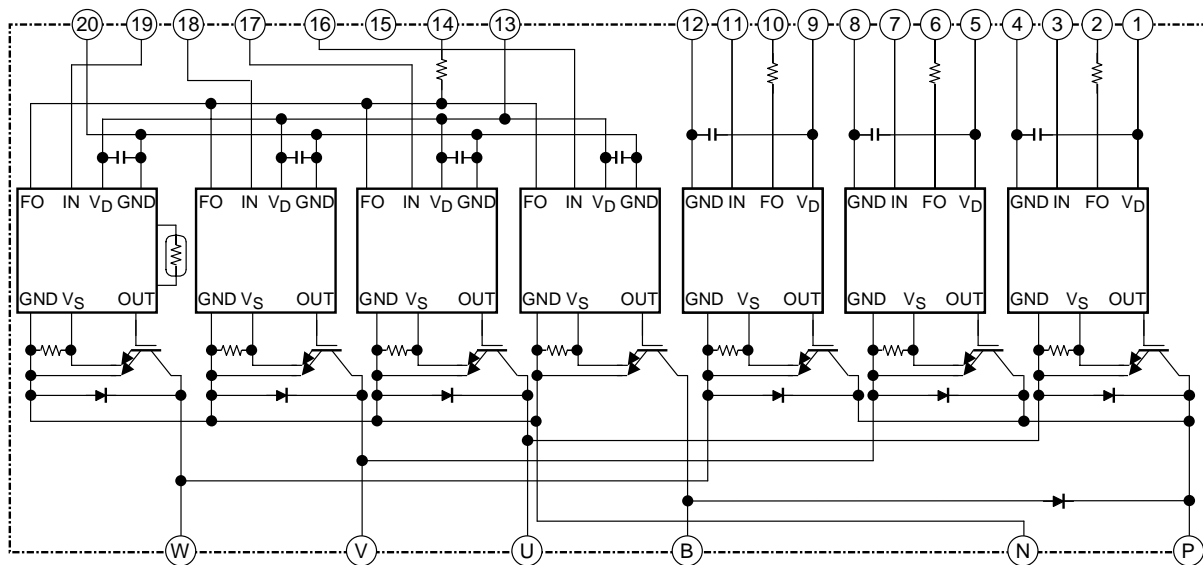

1. $V_D$ (U)	2. FO (U)	3. IN (U)	4. GND (U)	5. $V_D$ (V)	6. FO (V)	7. IN (V)
8. GND (V)	9. $V_D$ (W)	10. FO (W)	11. IN (W)	12. GND (W)	13. $V_D$ (L)	14. FO (L)
15. Open	16. IN (B)	17. IN (X)	18. IN (Y)	19. IN (Z)	20. GND (L)	

## Package Dimensions

Unit: mm

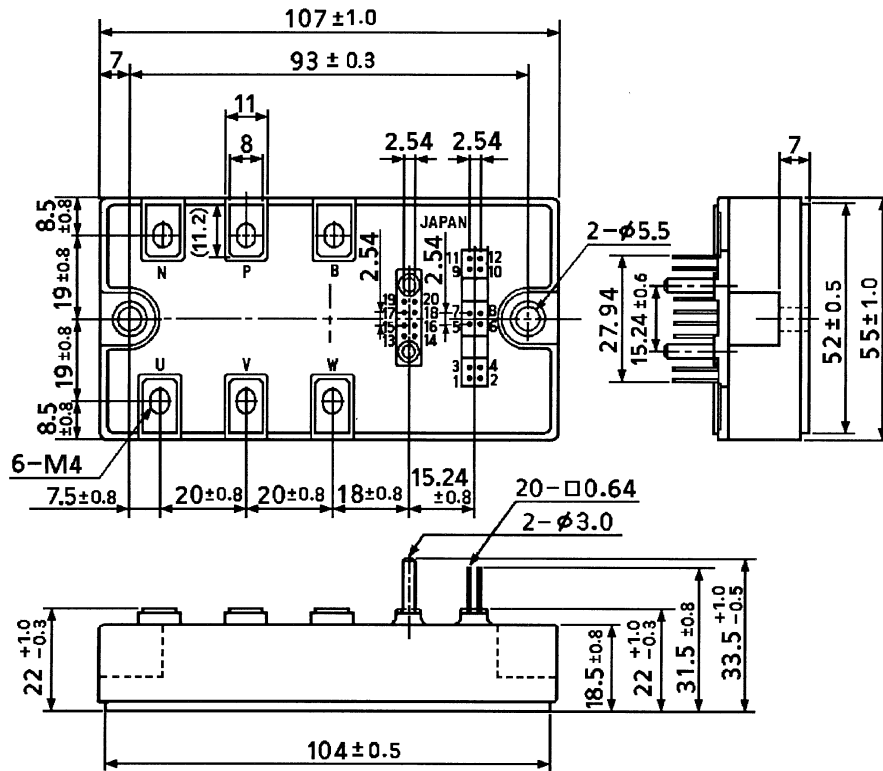

- |     |           |     |         |     |           |     |         |     |           |     |         |
|-----|-----------|-----|---------|-----|-----------|-----|---------|-----|-----------|-----|---------|
| 1.  | $V_D$ (U) | 2.  | FO (U)  | 3.  | IN (U)    | 4.  | GND (U) | 5.  | $V_D$ (V) | 6.  | FO (V)  |
| 7.  | IN (V)    | 8.  | GND (V) | 9.  | $V_D$ (W) | 10. | FO (W)  | 11. | IN (W)    | 12. | GND (W) |
| 13. | $V_D$ (L) | 14. | FO (L)  | 15. | Open      | 16. | IN (B)  | 17. | IN (X)    | 18. | IN (Y)  |
| 19. | IN (Z)    | 20. | GND (L) |     |           |     |         |     |           |     |         |

## Signal Terminal Layout

Unit: mm

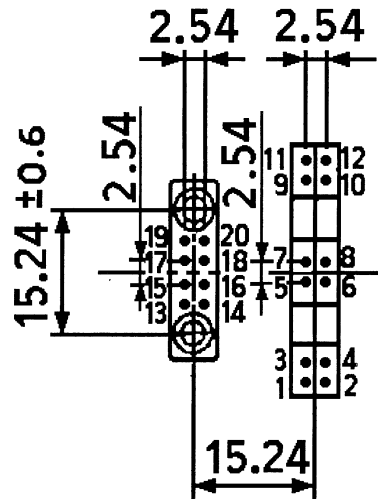

1.	V <sub>D</sub> (U)	2.	FO (U)	3.	IN (U)	4.	GND (U)	5.	V <sub>D</sub> (V)	6.	FO (V)
7.	IN (V)	8.	GND (V)	9.	V <sub>D</sub> (W)	10.	FO (W)	11.	IN (W)	12.	GND (W)
13.	V <sub>D</sub> (L)	14.	FO (L)	15.	Open	16.	IN (B)	17.	IN (X)	18.	IN (Y)
19.	IN (Z)	20.	GND (L)								

Maximum Ratings ( $T_j = 25^\circ\text{C}$ )

Stage	Characteristic	Condition	Symbol	Rating	Unit
Inverter	Supply voltage	P-N Power terminal	$V_{CC}$	450	V
	Collector-emitter voltage	—	$V_{CES}$	600	V
	Collector current	$T_c = 25^\circ\text{C}$ , DC	$I_C$	100	A
	Forward current	$T_c = 25^\circ\text{C}$ , DC	$I_F$	100	A
	Collector power dissipation	$T_c = 25^\circ\text{C}$ , DC	$P_C$	590	W
	Junction temperature	—	$T_j$	150	$^\circ\text{C}$
Brake	Supply voltage	P-N Power terminal	$V_{CC}$	450	V
	Collector-emitter voltage	—	$V_{CES}$	600	V
	Collector current	$T_c = 25^\circ\text{C}$ , DC	$I_C$	50	A
	Reverse voltage	—	$V_R$	600	V
	Forward current	$T_c = 25^\circ\text{C}$ , DC	$I_F$	50	A
	Collector power dissipation	$T_c = 25^\circ\text{C}$ , DC	$P_C$	340	W
	Junction temperature	—	$T_j$	150	$^\circ\text{C}$
Control	Control supply voltage	$V_D$ -GND Terminal	$V_D$	20	V
	Input voltage	IN-GND Terminal	$V_{IN}$	20	V
	Fault output voltage	FO-GND Terminal	$V_{FO}$	20	V
	Fault output current	FO sink current	$I_{FO}$	14	mA
Module	Operating temperature	—	$T_c$	-20~ +100	$^\circ\text{C}$
	Storage temperature Range	—	$T_{stg}$	-40~ +125	$^\circ\text{C}$
	Isolation voltage	AC 1 min	$V_{ISO}$	2500	V
	Screw torque (Terminal)	M4	—	2	N·m
	Screw torque (Mounting)	M5	—	3	

## Electrical Characteristics

## 1. Inverter stage

Characteristics	Symbol	Test Condition	Min	Typ.	Max	Unit	
Collector cut-off current	$I_{CEX}$	$V_{CE} = 600\text{ V}$	$T_j = 25^\circ\text{C}$	—	—	1	mA
			$T_j = 125^\circ\text{C}$	—	—	10	
Collector-emitter saturation voltage	$V_{CE(sat)}$	$V_D = 15\text{ V}$ $I_C = 100\text{ A}$ $V_{IN} = 15\text{ V} \leftrightarrow 0\text{ V}$	$T_j = 25^\circ\text{C}$	1.6	1.9	2.3	V
			$T_j = 125^\circ\text{C}$	—	2.1	—	
Forward voltage	$V_F$	$I_F = 100\text{ A}$ , $T_j = 25^\circ\text{C}$	—	2.1	2.5	V	
Switching time	$t_{on}$	$V_{CC} = 300\text{ V}$ , $I_C = 100\text{ A}$ $V_D = 15\text{ V}$ , $V_{IN} = 15\text{ V} \leftrightarrow 0\text{ V}$ $T_j = 25^\circ\text{C}$ , Inductive load (Note 1)	—	1.3	2.2	$\mu\text{s}$	
	$t_c(\text{on})$		—	0.3	—		
	$t_{rr}$		—	0.2	—		
	$t_{off}$		—	1.1	2.1		
	$t_c(\text{off})$		—	0.2	—		

Note 1: Switching time test circuit &amp; timing chart

## 2. Brake stage

Characteristics	Symbol	Test Condition	Min	Typ.	Max	Unit	
Collector cut-off current	$I_{CEX}$	$V_{CE} = 600\text{ V}$	$T_j = 25^\circ\text{C}$	—	—	1	mA
			$T_j = 125^\circ\text{C}$	—	—	10	
Collector-emitter saturation voltage	$V_{CE(sat)}$	$V_D = 15\text{ V}$ $I_C = 50\text{ A}$ $V_{IN} = 15\text{ V} \rightarrow 0\text{ V}$	$T_j = 25^\circ\text{C}$	—	1.8	2.2	V
			$T_j = 125^\circ\text{C}$	—	2.0	—	
Reverse current	$I_R$	$V_R = 600\text{ V}$	$T_j = 25^\circ\text{C}$	—	—	1	mA
			$T_j = 125^\circ\text{C}$	—	—	10	
Forward voltage	$V_F$	$I_F = 50\text{ A}, T_j = 25^\circ\text{C}$	1.5	1.9	2.3	V	
Switching time	$t_{on}$	$V_{CC} = 300\text{ V}, I_C = 50\text{ A}$ $V_D = 15\text{ V}, V_{IN} = 15\text{ V} \leftrightarrow 0\text{ V}$ $T_j = 25^\circ\text{C}, \text{Inductive load}$  (Note 1)	—	1.3	1.8	$\mu\text{s}$	
	$t_c(\text{on})$		—	0.65	—		
	$t_{rr}$		—	0.8	—		
	$t_{off}$		—	1.1	2.1		
	$t_c(\text{off})$		—	0.2	—		

Note 1: Switching time test circuit & timing chart

## 3. Control stage ( $T_j = 25^\circ\text{C}$ )

Characteristics	Symbol	Test Condition	Min	Typ.	Max	Unit	
Control circuit current	High side	$I_D(H)$	$V_D = 15\text{ V}$	—	13	17	mA
	Low side			$I_D(L)$	—	52	
Input on signal voltage	$V_{IN(\text{on})}$	$V_D = 15\text{ V}$	1.4	1.6	1.8	V	
Input off signal voltage	$V_{IN(\text{off})}$		2.2	2.5	2.8		
Fault output current	Protection	$I_{FO(\text{on})}$	$V_D = 15\text{ V}$	—	10	12	mA
	Normal			$I_{FO(\text{off})}$	—	—	
Over current protection trip level	Inverter	OC	$V_D = 15\text{ V}, T_j \leq 125^\circ\text{C}$	160	—	—	A
	Brake			80	—	—	
Short circuit protection trip level	Inverter	SC	$V_D = 15\text{ V}, T_j \leq 125^\circ\text{C}$	160	—	—	A
	Brake			80	—	—	
Over current cut-off time	$t_{off(OC)}$	$V_D = 15\text{ V}$	—	5	—	$\mu\text{s}$	
Over temperature protection	Trip level	OT	Case temperature	110	118	125	$^\circ\text{C}$
	Reset level			OTr	—	98	
Control supply under voltage protection	Trip level	UV	—	11.0	12.0	12.5	V
	Reset level			UVr	12.0	12.5	
Fault output pulse width	$t_{FO}$	$V_D = 15\text{ V}$	1	2	3	ms	

## 4. Thermal resistance ( $T_c = 25^\circ\text{C}$ )

Characteristics	Symbol	Test Condition	Min	Typ.	Max	Unit
Junction to case thermal resistance	$R_{th(j-c)}$	Inverter IGBT	—	—	0.210	$^\circ\text{C/W}$
		Inverter FRD	—	—	0.313	
		Brake IGBT	—	—	0.360	
		Brake FRD	—	—	0.600	
Case to fin thermal resistance	$R_{th(c-f)}$	Compound is applied	—	0.017	—	$^\circ\text{C/W}$

### Switching Time Test Circuit

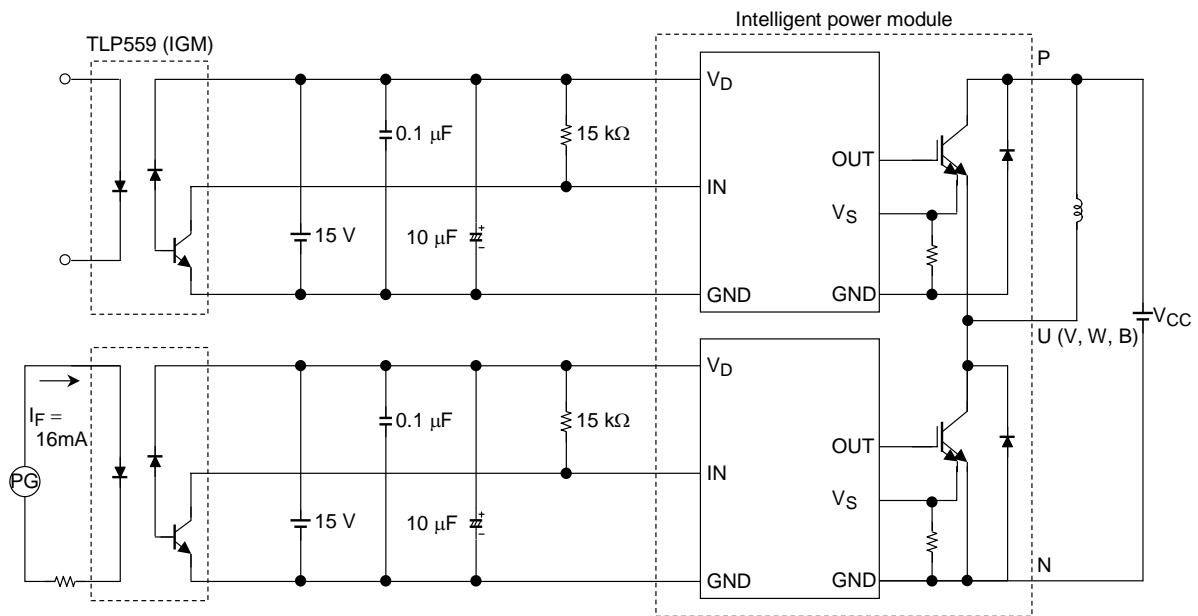

### Timing Chart

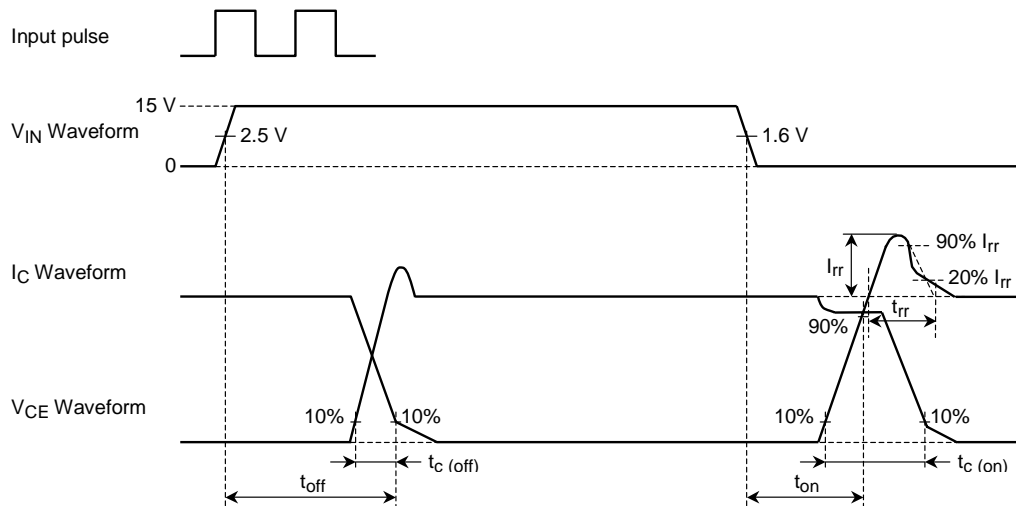

## 5. Recommended conditions for application

Characteristics	Symbol	Test Condition	Min	Typ.	Max	Unit
Supply voltage	$V_{CC}$	P-N Power terminal	—	300	400	V
Control supply voltage	$V_D$	$V_D$ -GND Signal terminal	13.5	15	16.5	V
Carrier frequency	$f_c$	PWM Control	—	—	20	kHz
Dead time	$t_{dead}$	Switching time test circuit (See page.6) (Note 2)	3	—	—	$\mu s$

Note 2: The table lists Dead time requirements for the module input, excluding photocoupler delays. When specifying dead time requirements for the photocoupler input, please add photocoupler delays to the dead time given above.

### Dead Time Timing Chart

