

TOSHIBA GTR MODULE SILICON N CHANNEL IGBT

MG180V2YS40

HIGH POWER SWITCHING APPLICATIONS

MOTOR CONTROL APPLICATIONS

EQUIVALENT CIRCUIT

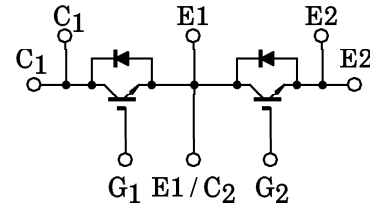

- The Electrodes are Isolated from Case
- High Input Impedance
- Includes a Complete Half Bridge in One Package.
- Enhancement-Mode
- High Speed : $t_f=1.5\mu s$ (Max.) ($I_C=180A$)
 $t_{rr}=0.6\mu s$ (Max.) ($I_F=180A$)
- Outline : TOSHIBA 2-109D2A
(See page 3 for the device outline)
- Weight : 550g (Typ.)

MAXIMUM RATINGS ($T_a = 25^\circ C$)

CHARACTERISTIC		SYMBOL	RATING	UNIT
Collector-Emitter Voltage		V_{CES}	1700	V
Gate-Emitter Voltage		V_{GES}	± 20	V
Collector Current	DC	I_C	180	A
	1ms	I_{CP}	360	
Forward Current	DC	I_F	180	A
	1ms	I_{FM}	360	
Collector Power Dissipation ($T_c = 25^\circ C$)		P_C	1800	W
Junction Temperature		T_j	150	$^\circ C$
Storage Temperature Range		T_{stg}	-40~125	$^\circ C$
Isolation Voltage		V_{Isol}	4000 (AC 1 min.)	V
Screw Torque (Terminal / Mounting)		—	3 / 3	N·m

961001EAA2

● TOSHIBA is continually working to improve the quality and the reliability of its products. Nevertheless, semiconductor devices in general can malfunction or fail due to their inherent electrical sensitivity and vulnerability to physical stress. It is the responsibility of the buyer, when utilizing TOSHIBA products, to observe standards of safety, and to avoid situations in which a malfunction or failure of a TOSHIBA product could cause loss of human life, bodily injury or damage to property. In developing your designs, please ensure that TOSHIBA products are used within specified operating ranges as set forth in the most recent products specifications. Also, please keep in mind the precautions and conditions set forth in the TOSHIBA Semiconductor Reliability Handbook.

● The information contained herein is presented only as a guide for the applications of our products. No responsibility is assumed by TOSHIBA CORPORATION for any infringements of intellectual property or other rights of the third parties which may result from its use. No license is granted by implication or otherwise under any intellectual property or other rights of TOSHIBA CORPORATION or others.

● The information contained herein is subject to change without notice.

ELECTRICAL CHARACTERISTICS (Ta = 25°C)

CHARACTERISTIC		SYMBOL	TEST CONDITION	MIN.	TYP.	MAX.	UNIT
Gate Leakage Current		I_{GES}	$V_{GE} = \pm 20V, V_{CE} = 0$	—	—	± 150	nA
Collector Cut-off Current		I_{CES}	$V_{CE} = 1700V, V_{GE} = 0$	—	—	1.5	mA
Gate-Emitter Cut-off Voltage		$V_{GE} (off)$	$I_C = 180mA, V_{CE} = 5V$	4.0	—	8.0	V
Collector-Emitter Saturation Voltage		$V_{CE} (sat)$	$I_C = 180A, V_{GE} = 15V$	—	3.2	4.5	V
Input Capacitance		C_{ies}	$V_{CE} = 10V, V_{GE} = 0, f = 1MHz$	—	24600	—	pF
Switching Time	Turn-on Delay Time	$t_d (on)$	Inductive Load $V_{CC} = 900V$ $I_C = 180A$ $V_{GE} = \pm 15V$ $R_G = 2.7\Omega$ (Note 1)	—	0.1	—	μs
	Rise Time	t_r		—	0.1	—	
	Turn-on Time	t_{on}		—	0.5	—	
	Turn-off Delay Time	$t_d (off)$		—	0.4	—	
	Fall Time	t_f		—	0.5	1.5	
	Turn-off Time	t_{off}		—	1.0	—	
Forward Voltage		V_F	$I_F = 180A, V_{GE} = 0$	—	3.7	5.0	V
Reverse Recovery Time		t_{rr}	$I_F = 180A, V_{GE} = -15V$ $di / dt = 1000A / \mu s$ (Note.1)	—	0.3	0.6	μs
Thermal Resistance		$R_{th} (j-c)$	Transistor Stage	—	—	0.069	$^{\circ}C / W$
			Diode Stage	—	—	0.25	

Note 1 Switching Time and Reverse Recovery Time Test Circuit & Timing Chart

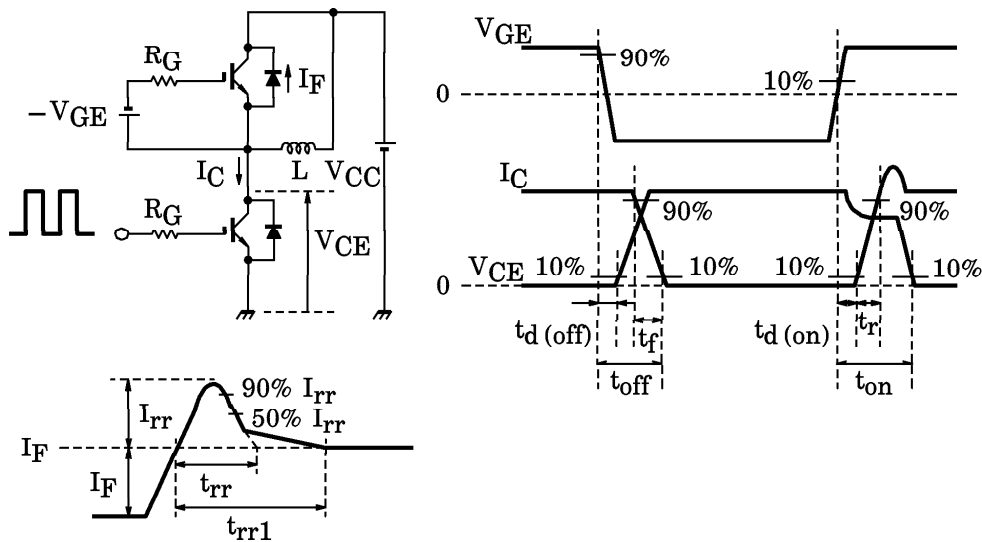

OUTLINE : TOSHIBA 2-109D2A

Unit in mm

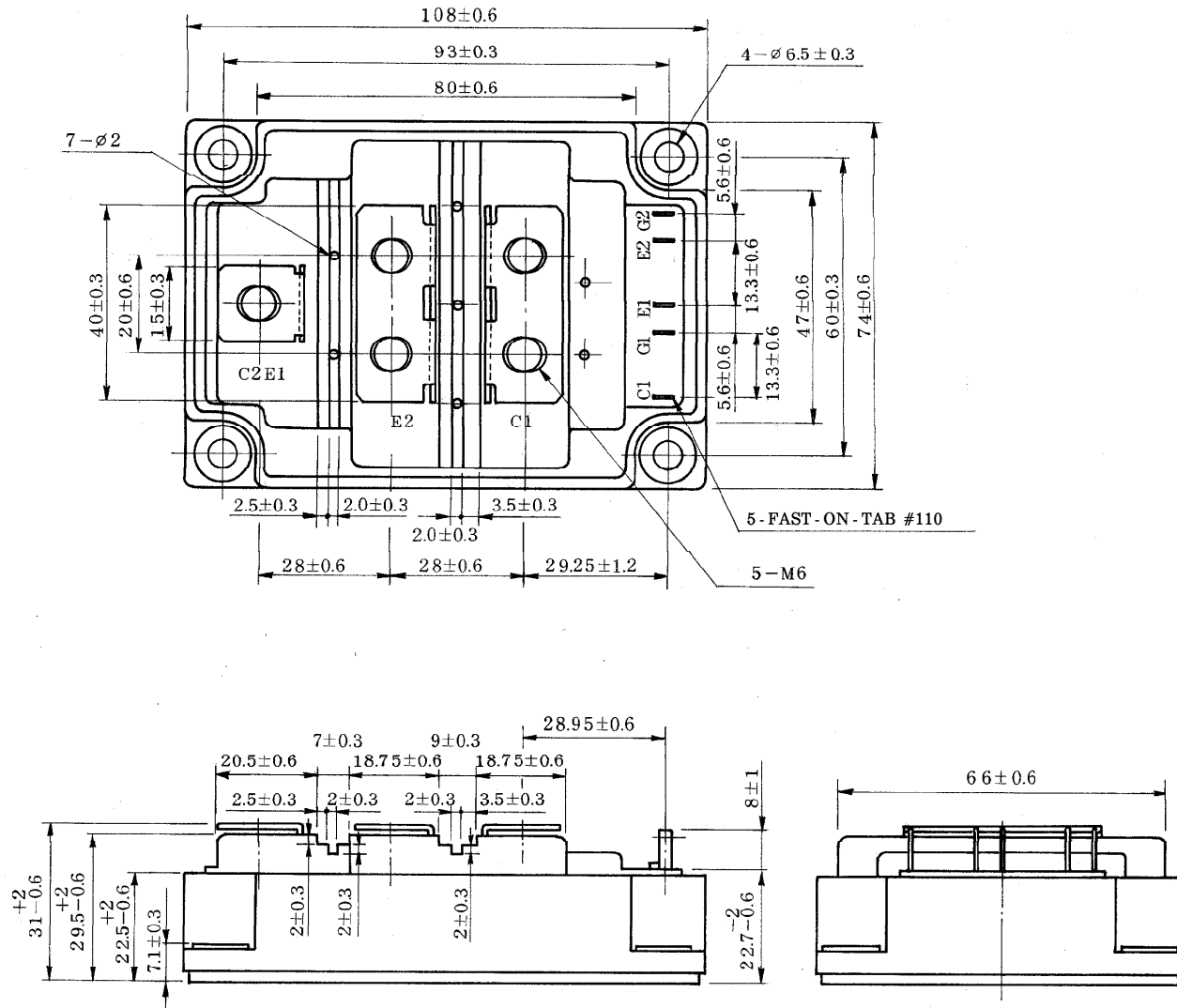

Weight : 550g (Typ.)

