

DIODE MODULE (F.R.D.)

MDF(R)250A-L/M

TOP



MDF(R)250A-L/M are high speed diode with flat mounting base which is designed for switching application of high power.

- $I_{F(AV)}$ 250A $V_{RRM}=400V$
- Easy Construction with Anode (F) Type and Cathode (R) Type
- Reverse Recovery Time (t_{rr}) L Type: 450ns, M Type: 550ns
- High Reliability by Glass passivated Chips

(Applications)

Switching Power Supply.
Inverter Welding Power Supply

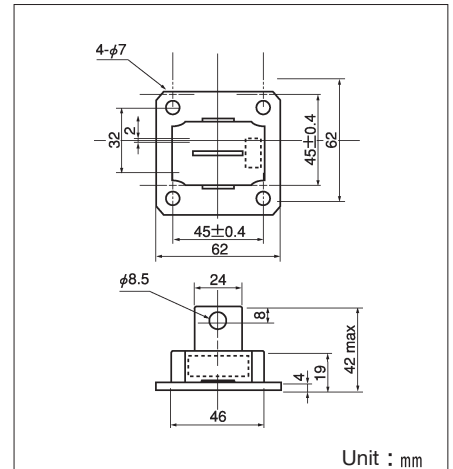
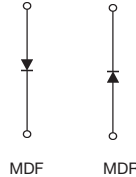

Maximum Ratings

Symbol	Item	Ratings			Unit
		MDF(R)250A20L/M	MDF(R)250A30L/M	MDF(R)250A40L/M	
V_{RRM}	Repetitive Peak Reverse Voltage	200	300	400	V
V_{RSM}	Non-Repetitive Peak Reverse Voltage	240	360	480	V
$V_{R(DC)}$	D.C. Reverse Voltage	160	240	320	V

Symbol	Item	Conditions	Ratings	Unit	
$I_{F(AV)}$	Average Forward Current	Single phase, half wave, 180° conduction, $T_c:L/M 83^\circ/85^\circ C$	250	A	
$I_{F(RSM)}$	R.M.S. Forward Current	Single phase, half wave, 180° conduction, $T_c:L/M 83^\circ/85^\circ C$	390	A	
I_{FSM}	Surge Forward Current	1/2 cycle, 50/60Hz, peak value, non-repetitive	4000/4500	A	
I^2t	I^2t	Value for one cycle of surge current	84000	A ² S	
T_j	Operating Junction Temperature		-30~+150	°C	
T_{stg}	Storage Temperature		-30~+125	°C	
	Mounting Torque	Mounting (M6)	Recommended Value 2.5~3.9 (25~40)	4.7 (48)	N·m (kgf·cm)
		Terminal (M8)	Recommended Value 8.8~10 (90~105)	11 (115)	
	Mass	Typical Value	170	g	

Electrical Characteristics

Symbol	Item	Conditions	Ratings	Unit	
I_{RRM}	Repetitive Peak Reverse Current, max	at V_{DRM} , single phase, half wave, $T_j=150^\circ C$	60	mA	
V_{FM}	Forward Voltage Drop, max	Foward current 800A, $T_j=25^\circ C$ Inst, measurement	L	1.4	V
			M	1.3	
$R_{th(j-c)}$	Thermal Impedance, max	Junction to case	0.2	°C/W	
t_{rr}	Reverse Recovery Time, max	$T_j=25^\circ C$, $I_F=2A$, $di/dt=20A/\mu s$	L	450	ns
			M	550	

M Type

Maximum Forward Characteristics

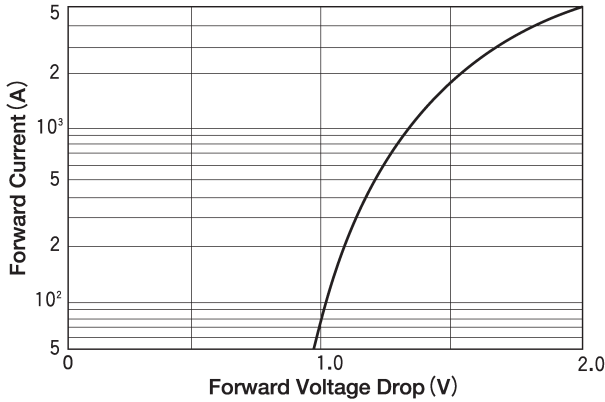

Average Forward Current vs. Power Dissipation

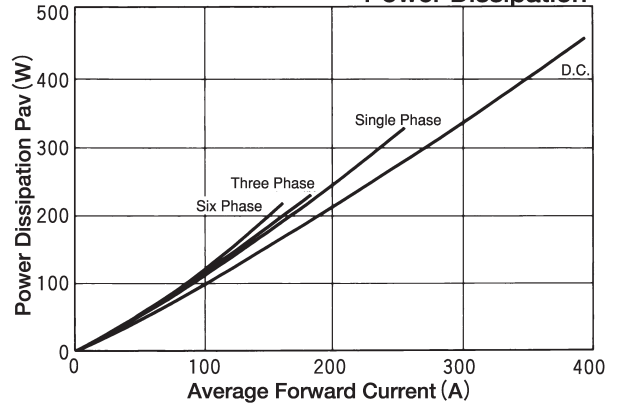

Average Forward Current vs. Allowable Case Temperature

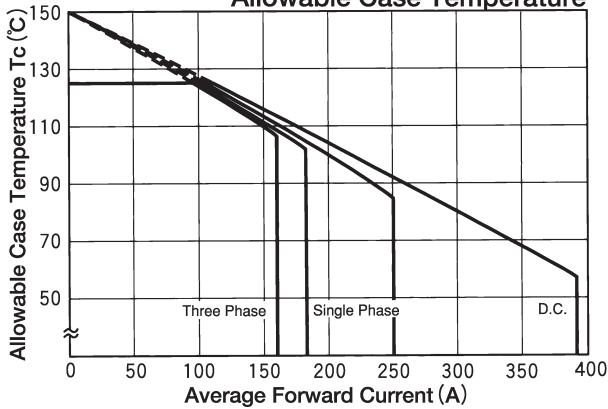

Cycle Surge Forward Current Rating (Non-Repetitive)

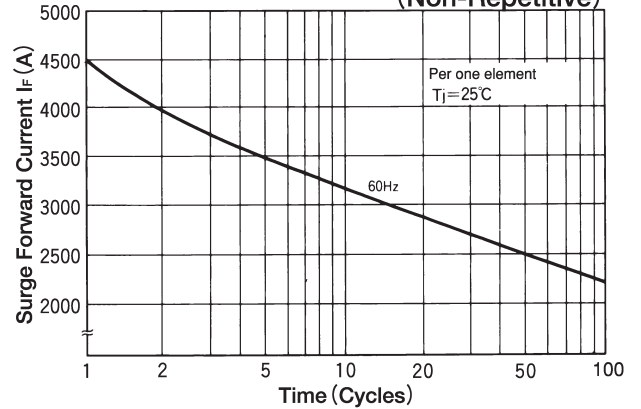

Transient Thermal Impedance

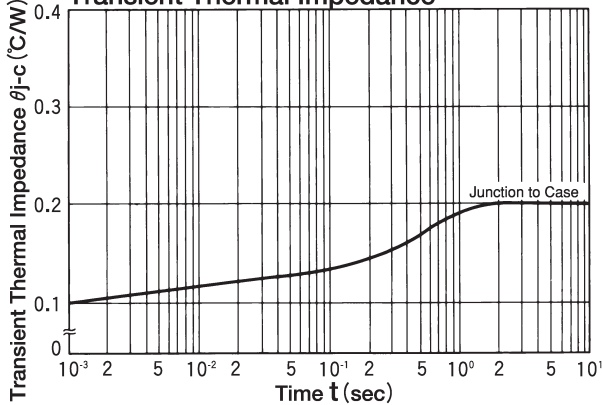

L Type

Maximum Forward Characteristics

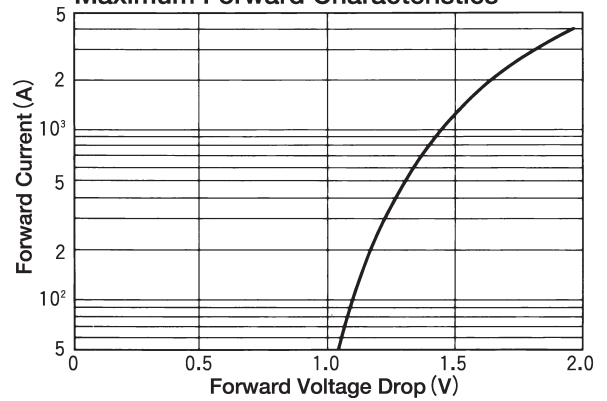

Average Forward Current vs. Allowable Case Temperature

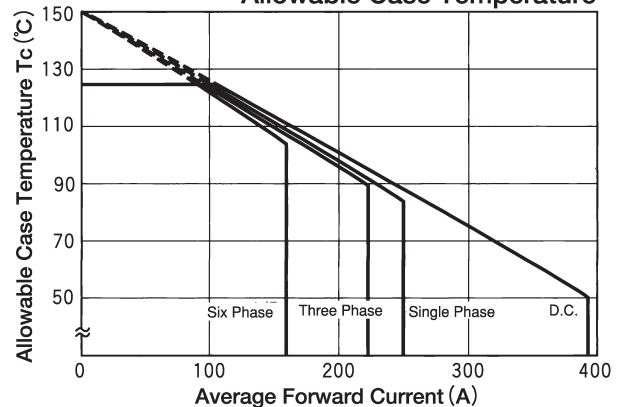

Average Forward Current vs. Power Dissipation

