

USING HYBRID GATE DRIVERS AND GATE DRIVE POWER SUPPLIES

5.0 Using Hybrid Gate Drivers

Mitsubishi offers four single in-line hybrid ICs for driving IGBT modules. All four drivers are high speed devices designed to convert logic level control signals into optimal IGBT gate drive. Input signals are isolated from the IGBT drive using high speed optocouplers with 15,000V/ms

common mode noise immunity. This feature allows convenient common referencing of high and low side control signals. Mitsubishi IGBT drivers are designed to provide the pulse currents necessary for high performance switching applications and to maintain sufficient off bias to guarantee ruggedness. Hybrid IGBT drivers simplify gate drive

design by minimizing the number of components required. In addition to high performance gate drive, the M57959L and the M57962L provide short-circuit protection. The basic package outlines of the four Mitsubishi drivers are shown in Figure 5.1. Table 5.1 lists the key electrical characteristics of each hybrid driver.

Figure 5.1 Hybrid IGBT Gate Drivers

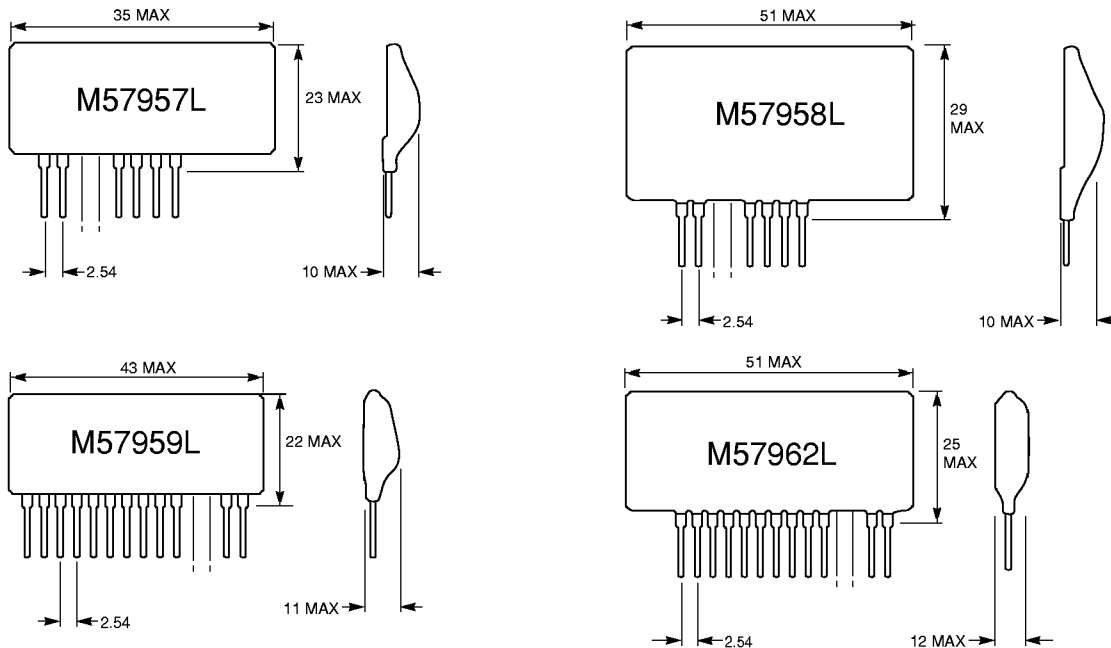

All Dimensions in mm.

Table 5.1 Recommended Gate Driver Applications

| Gate Drive Circuit | Peak Output Current | Short Circuit Protection | Optimum Application Range* | |
|------------------------|---------------------|--------------------------|----------------------------|------------------------------|
| | | | For 600V IGBT Modules | For 1200V/1400V IGBT Modules |
| M57957L | 2 Amps | No | Up to 100A | Up to 50A |
| M57958L | 5 Amps | No | Up to 400A | Up to 200A |
| M57959L | 2 Amps | Yes | Up to 100A | Up to 50A |
| M57962L | 5 Amps | Yes | Up to 400A | Up to 200A |
| M57958L with Booster** | 20 Amps | No | Up to 600A | Up to 1000A |
| M57962L with Booster** | 20 Amps | Yes | Up to 600A | Up to 1000A |

*Use R_G specified in the switching time section of the IGBT module data sheet.

**See Section 5.10

USING HYBRID GATE DRIVERS AND GATE DRIVE POWER SUPPLIES

5.1 Output Current Limit

When using hybrid gate drivers R_G must be selected such that the output current rating (I_{OP}) is not exceeded. If R_G is computed using Equation 5.1 then I_{OP} will not be exceeded under any condition.

Equation 5.1 Conservative equation for minimum R_G

$$R_{G(MIN)} = (V_{CC} + V_{EE})/I_{OP}$$

Example:

With $V_{CC} = 15V$ and $-V_{EE} = 10V$ $R_{G(MIN)}$ for M57958L will be:

$$R_G = (15V + 10V)/5A = 5 \text{ ohms}$$

In most applications this limit is unnecessarily conservative. Considerably lower values of R_G can usually be used. The expression for $R_{G(MIN)}$ should be modified to include the effects of parasitic inductance in the drive circuit, IGBT module internal impedance and the finite switching speed of the hybrid drivers output stage. Equation 5.2 is an improved version of Equation 5.1 for $R_{G(MIN)}$.

Equation 5.2 Improved equation for $R_{G(MIN)}$

$$R_{G(MIN)} = (V_{CC} + V_{EE}) / (I_{OP} - (R_G)_{INT} - \phi)$$

Large IGBT modules that contain parallel chips have internal gate resistors that balance the gate drive and prevent internal oscillations. The parallel combination of these internal resistors is $R_{G(INT)}$. $R_{G(INT)}$

ranges from 0.75 ohm in large IGBT modules like CM600HA-24H to 3.0 ohms in smaller modules like CM150DY-12H with two parallel chips. The value of ϕ depends on the parasitic inductance of the gate drive circuit and the switching speed of the hybrid driver. The exact value of ϕ is difficult to determine. It is often desirable to estimate the minimum value of R_G that can be used with a given hybrid driver circuit and IGBT module by monitoring the peak gate current while reducing R_G until the rated I_{OP} is reached. The minimum restriction on R_G often limits the switching performance and maximum usable operating frequency when large modules outside of the drivers optimum application range are being driven. Further steps to address this issue are provided in Section 5.10.

5.2 Power Supply Requirements

Power is usually supplied to hybrid IGBT gate drivers from low voltage DC power supplies that are isolated from the main DC bus voltage. Isolated power supplies are required for high side gate drivers because the emitter potential of high side IGBTs is constantly changing. Isolated power supplies are often desired for low side IGBT gate drivers in order to eliminate ground loop noise problems. The gate drive supplies should have an isolation voltage rating of at least two times the IGBTs V_{CES} rating (i.e. $V_{ISO} = 2400V$ for 1200V IGBT). In systems with several isolated supplies intersupply capacitances must be minimized in order to avoid coupling of common mode

Figure 5.2 Hybrid Driver Power Supply

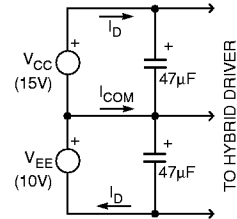

noise. The recommended power supply configuration for Mitsubishi hybrid IGBT gate drivers is shown in Figure 5.2. Two supplies are used in order to provide the on- and off-bias for the IGBT. The recommended on bias supply (V_{CC}) voltage is +15V and the recommended off-bias supply voltage (V_{EE}) is -10V.

Normally these supplies should be regulated to $\pm 10\%$ however operation within the range indicated on the individual driver data sheets is acceptable. Electrolytic or tantalum decoupling capacitors should be connected at the power supply input pins of the hybrid driver. These capacitors supply the high pulse currents required to drive the IGBT gate. The amount of capacitance required depends on the size of the IGBT module being driven. A 47µF capacitor is sufficient for most applications.

5.2.1 Supply Current

The current that must be supplied to the IGBT driver is the sum of two components. One component is the quiescent current required to bias the drivers internal circuits. The current is constant for fixed values of V_{CC} and V_{EE} . The second component is the current re-

USING HYBRID GATE DRIVERS AND GATE DRIVE POWER SUPPLIES

quired to drive the IGBT gate. This current is directly proportional to the operating frequency and the total gate charge (Q_G) of the IGBT being driven. With small IGBT modules and at low operating frequencies the quiescent current will be the dominant component. The amount of current that must be supplied to the hybrid driver when $V_{CC} = 15V$ and $V_{EE} = -10V$ can be determined from Equations 5.3 and 5.4.

Equation 5.3
Required supply current for M57957L and M57958L

$$I_D = Q_G \times f_{PWM} + 13mA$$

Equation 5.4
Required supply current for M57959L and M57962L

$$I_D = Q_G \times f_{PWM} + 18mA$$

Where:

- I_D = Required supply current
- Q_G = Gate charge (See Section 4.6.3)
- f_{PWM} = Operating frequency

5.2.2 Single Supply Operation

The current drawn from V_{CC} (I_{D+}) is nearly equal to the current drawn from V_{EE} (I_{D-}). Only a small amount of current flows in the common connection (I_{COM}). In many applications it is desirable to operate the hybrid driver from a single isolated supply. An easy method of accomplishing this is to create the common potential using a resistor and a zener diode. In order to size the resistor for minimum loss we must first determine the current flowing in the common connection

Figure 5.3 Single Supply Operation of Hybrid IGBT Drivers

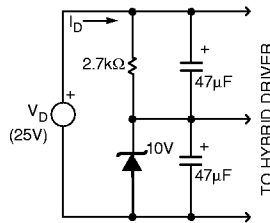

(I_{COM}). In M57957L and M57958L a common connection current of about 2.5mA is required to bias internal circuits. In M57959L and M57962L about 3.5mA flows from the detect pin through the IGBT to the common connection. The circuit in Figure 5.3 uses a zener supply designed for about 5mA to supply the common current. This circuit allows operation of Mitsubishi hybrid drivers from a single isolated 25 volt DC supply.

When the power supply circuit shown in Figure 5.3 is used with M57957L and M57958L the required bias voltage at pin 5 of the hybrid driver appears after a delay caused by the 2.7kΩ resistor and the 47μF capacitor. This delay may cause these drivers to generate an ON output pulse during power up. In applications where the main DC bus voltage is applied before the gate drive power supplies are on and stabilized the circuit in Figure 5.4 should be used.

The voltage of the single supply and the zener diode can be varied to allow use of standard supplies. For example, if a 24V DC-to-DC

Figure 5.4 Improved Power Supply Circuit for M57957L and M57958L

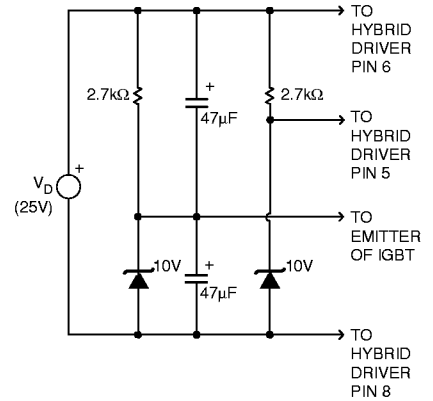

converter is to be used then a 9V zener diode would give +15/-9 which is acceptable for all of the hybrid gate drivers. The two limiting factors that need to be observed if changes are made are:

- (1) Voltages must be within the allowable range specified on the gate driver data sheet and
- (2) The turn on supply should be 15V+/-10% for proper IGBT performance.

5.3 Total Power Dissipation

The hybrid IGBT driver has a maximum allowable power dissipation that is a function of the ambient temperature. With $V_{CC} = 15V$ and $V_{EE} = -10V$ the power dissipated in the driver can be estimated using Equation 5.5.

USING HYBRID GATE DRIVERS AND GATE DRIVE POWER SUPPLIES

Equation 5.5 Total power Dissipation

$$P_D = I_D \times (V_{CC} + V_{EE})$$

The power computed using Equation 5.5 can then be compared to the derating curves shown in Figures 5.5 through 5.8 to determine the maximum allowable ambient temperature. The power computed using Equation 5.5 includes the dissipation in the external gate resistor (R_G). This loss is outside the hybrid driver and can be subtracted from the result of Equation 5.5. The dissipation in R_G is difficult to estimate because it depends on drive circuit parasitic inductance, IGBT module type and the hybrid driver's switching speed. In most applications the loss in R_G can be ignored. Direct use of Equation 5 will result in a conservative design with the included loss of R_G acting as a safety margin. When operating large modules at high frequencies the limitations on ambient temperature may be significant.

5.4 Application Circuit for M57957L and M57958L

An internal schematic and example application circuit for the M57957L and M57958L are shown in Figures 5.9 and 5.10. For optimum performance parasitic inductance in the gate drive loop must be minimized. This is accomplished by connecting the 47 μ F decoupling capacitors as close as possible to the pins of the hybrid driver and by minimizing the lead length between the drive circuit and the IGBT. The zeners shown should be rated at about 18 volts and be connected as close to the IGBT's gate as possible. These zeners protect the gate during switching and short circuit operation.

The gate driver has a built in 185 ohm input resistor that is designed to provide proper drive for the internal opto isolator when $V_{IN} = 5V$. If other input voltages are desired an external resistor should be added to maintain the proper opto drive current of 16ma. The value of the required external resistor can be computed by assuming the forward voltage drop of the opto diode is 2V. For example:

If 15V drive is required then

$$R_{ext} = (15V - 2V) \div 16ma - 185\Omega = 630\Omega.$$

5.5 Short-Circuit Protection Using Desaturation Techniques

The M57959L and M57962L have built in circuits that will protect the IGBT from short circuits by detecting desaturation. When a short circuit occurs a high current will flow in the IGBT causing its collector to emitter voltage to increase to a level much higher than normal. The hybrid driver detects this condition and quickly turns the IGBT off, saving it from certain destruction.

USING HYBRID GATE DRIVERS AND GATE DRIVE POWER SUPPLIES

Figure 5.5 Derating Curve for M57957L

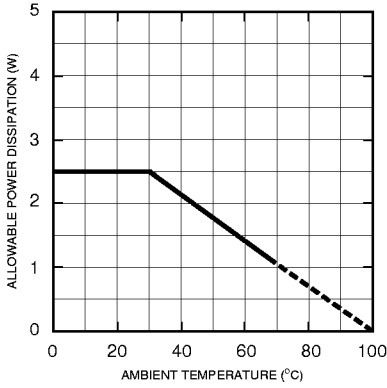
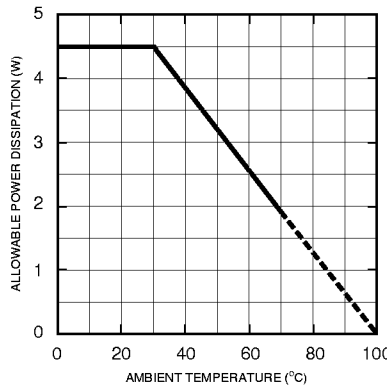

Figure 5.6 Derating Curve for M57958L



5.6 Operation of M57959L and M57962L

Figure 5.11 is a flow diagram showing the operation of the short protection in M57959L and M57962L. The hybrid driver monitors the collector emitter voltage (V_{CE}) of the IGBT. Normally, when an on signal is applied to the input of the driver the IGBT will turn on and V_{CE} will quickly attain its low on-state value of $V_{CE(SAT)}$. If a short circuit is present when the on signal is applied a large current will flow in the IGBT and V_{CE} will remain high. A short circuit is detected by the hybrid driver when V_{CE} remains greater than the desaturation trip level (V_{SC}) for longer than t_{TRIP} after the input on signal is applied. The t_{TRIP} delay is used to avoid false tripping by allowing enough time for normal turn on of the IGBT. The hybrid driver initiates a controlled slow turn off and generates a fault output signal when a short circuit is detected. The slow turn off helps to control dangerous transient voltages that can occur when high short circuit currents are interrupted. The output of the driver will remain disabled and the fault signal will remain active for t_{RESET} after a short circuit is detected. The input signal of the driver must be in its off state in order for the fault signal to be reset.

Figure 5.7 Derating Curve for M57959L

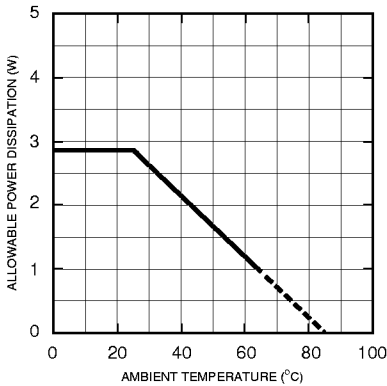
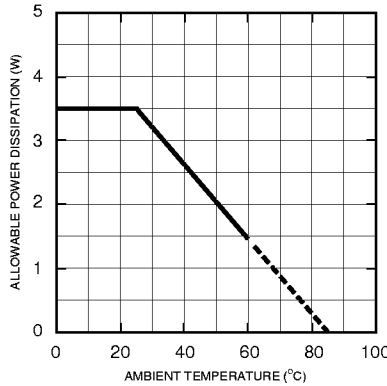

Figure 5.8 Derating Curve for M57962L



USING HYBRID GATE DRIVERS AND GATE DRIVE POWER SUPPLIES

Figure 5.9 Internal Schematic Diagram of M57957L and M57958L

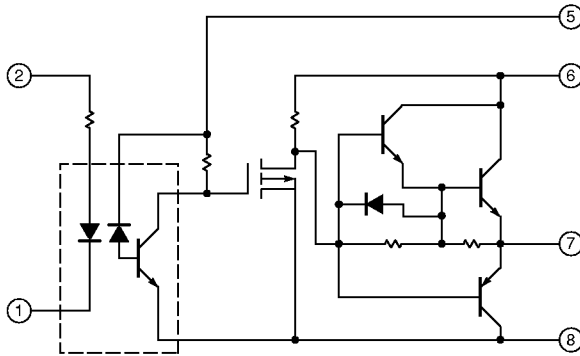

Figure 5.10 Application Circuit for M57957L and M57958L

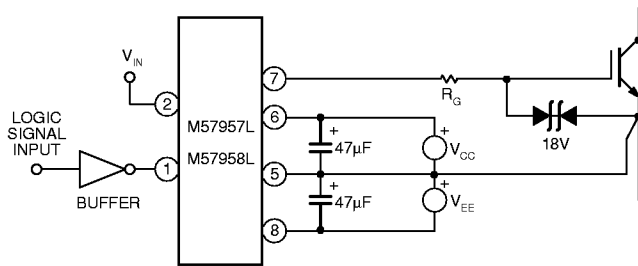
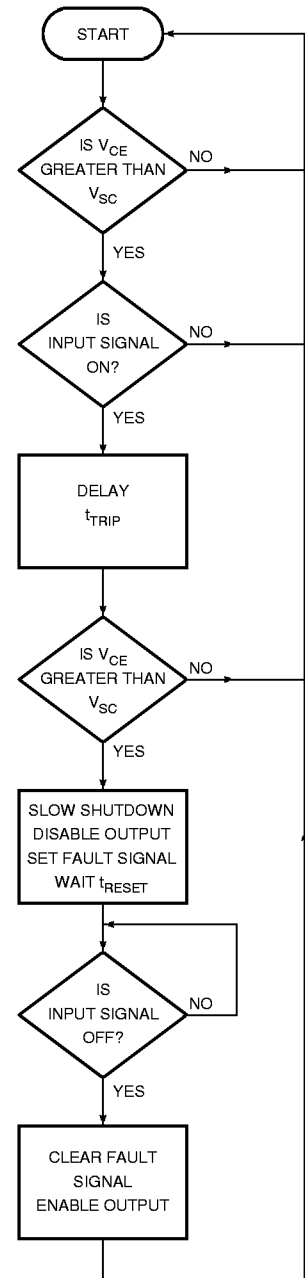

Figure 5.11 Protection Circuit Operation



USING HYBRID GATE DRIVERS AND GATE DRIVE POWER SUPPLIES

5.7 Application Circuit for M57959L and M57962L

Figure 5.12 is a block diagram of the M57959L and M57962L drivers showing the logical implementation of the flow diagram in Figure 5.11. Figure 5.13 is an example application circuit for M57959L and M57962L. Parasitic inductance in the drive circuit should be minimized using the techniques described for the M57957L and M57958L in Section 5.4. Pins (3,7,9,10) are used for factory testing and should not be connected to any external circuit. The detect diode (D1) must be fast recovery (approximately 100ns) and should be rated at a voltage equal to or higher than the IGBT module being driven. The 20V zener DZ1 is recommended in order to protect the hybrid IC's detect input from transient voltages that can occur during recovery of the detect diode. This zener can be eliminated if the detect diode's recovery remains fast and soft over its entire temperature range and pin 1 of the hybrid IC remains free of high voltage transients and ringing.

The gate driver has a built in 185 ohm input resistor that is designed to provide proper drive for the internal opto isolator when $V_{IN} = 5V$. If other input voltages are desired an external resistor should be added to maintain the proper opto drive current of 16mA. The value of the required external resis-

tor can be computed by assuming the forward voltage drop of the opto diode is 2V. For example:

If 15V drive is required then

$$R_{ext} = (15V - 2V) \div 16ma = 185\Omega$$

5.8 Adjusting the Desaturation Trip Time (t_{TRIP})

The hybrid drivers built in t_{TRIP} delay will work for most applications. However when large modules are being driven with near maximum gate resistance the driver may incorrectly detect a

Figure 5.12 Block Diagram for M57959L

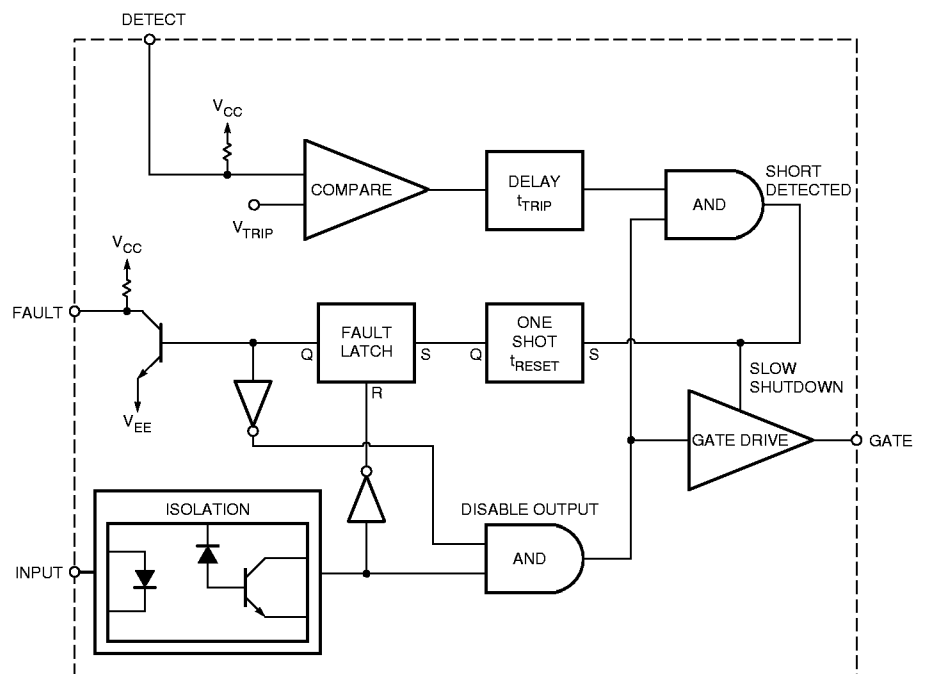
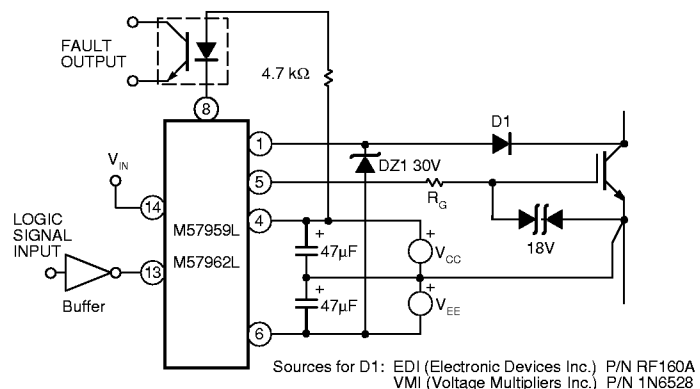

Figure 5.13 Block Diagram for M57959L



USING HYBRID GATE DRIVERS AND GATE DRIVE POWER SUPPLIES

short circuit. The false trip occurs because it takes longer than t_{TRIP} for the module to reach its low on-state voltage. In these applications the t_{TRIP} delay can be extended by connecting a capacitor from pin 2 to V_{CC} . Figure 5.14 shows the typical increase in t_{TRIP} as a function of the external capacitor value for M57959L and M57962L.

5.9 Operational Waveforms

Figure 5.15 is a typical waveform showing the gate to emitter voltage during a slow shutdown for M57962L. Approximately 2.4ms after the detect input (pin 1) voltage exceeds V_{SC} the gate to emitter voltage is slowly brought to zero in about 2ms. Figure 5.16 shows the collector-emitter voltage (V_{CE}) and collector current (I_C) for an IGBT module during a short circuit. This waveform shows the effectiveness of the slow shutdown in controlling transient voltage.

5.10 Driving Large IGBT Modules

In order to achieve efficient and reliable operation of high current, high voltage IGBT modules, a gate driver with high pulse current capability and low output impedance is required. Mitsubishi hybrid gate drivers are designed to perform this function as stand alone units in most applications. However, for optimum performance with large modules, it may be necessary to add an output booster stage to the hybrid gate driver.

When using the hybrid gate drivers as stand alone units with IGBT modules outside the range

specified in Table 5.1, three things must be considered. First, the maximum peak output current rating of the hybrid gate driver places a restriction on the minimum value of R_G that can be used. For example, the minimum allowable R_G for M57962L is about 5 ohms (for additional information refer to Section 5.1). This value is higher than the recommended value for many large IGBTs. Using R_G larger than the data sheet value will cause an increase in $t_{d(on)}$, $t_{d(off)}$, t_r and turn-on switching losses. In high frequency (more than 5kHz) applications these additional losses are usually unacceptable. Second, even if the additional losses and slower switching times are acceptable, the drivers allowable power dissipation must be considered. At an ambient temperature of 60°C, the M57962L is permitted to dissipate a maximum of about 1.5W (for more information refer to Section 5.3). If a CM600HA-24H is being used, the driver will dissipate 1.5W at a switching frequency of 14kHz. In this case, operation at a higher frequency than 14kHz will cause the driver to overheat. Lastly, the driver's slow shutdown becomes less effective when it is used with large devices. This occurs because current that flows to the gate through the relatively high reverse transfer capacitance (C_{res}) of large devices can not be absorbed by the driver. Its output impedance is not low enough. The slow shutdown may become less slow and a larger turn-off snubber capacitor may be required. This third limitation is perhaps the most serious. In some cases, the hybrid driver may completely lose control of the gate voltage and allow it to

Figure 5.14 Adding Capacitance to Extend t_{TRIP}

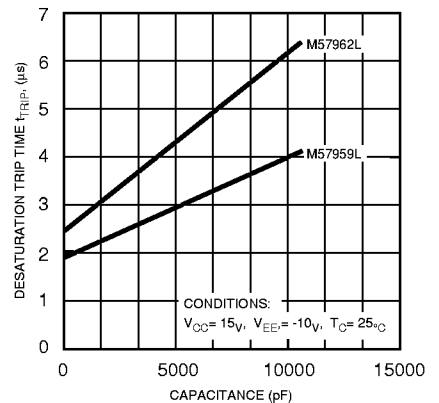

Figure 5.15 V_{GE} and V_{DETECT} Waveform

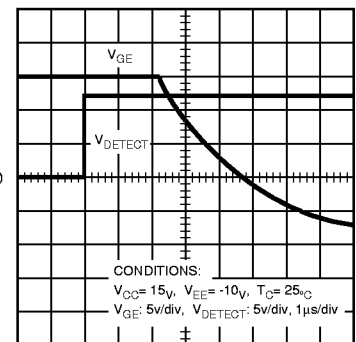
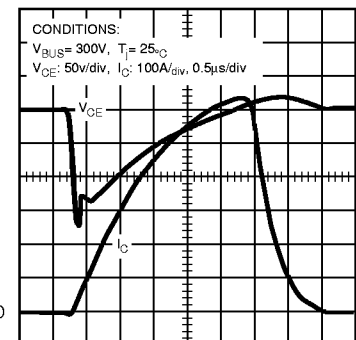

Figure 5.16 Short-Circuit Shutdown Waveform



USING HYBRID GATE DRIVERS AND GATE DRIVE POWER SUPPLIES

climb above 15V. If this happens, the short circuit durability of the IGBT module may be compromised.

All of the limitations outlined above can be overcome by adding a discrete npn/pnp complimentary output stage to the hybrid driver. One possible implementation is shown in Figure 5.18.

The NPN and PNP booster transistors should be fast switching ($t_f < 200\text{nS}$) and have sufficient current gain to deliver the desired peak output current. Table 5.2 lists some combinations of booster transistors that can be used in the circuit shown in figure 5.18. Normally, either M57958L or M57962L is used to drive the booster stage. However, if the gain of the booster transistors is sufficiently high the lower current M57957L and M57959L can be used. If very high gain or Darlington type transistors are used in the booster stage care must be exercised to avoid oscillations in the output stage. It may become necessary to add resistance from base to emitter on the booster transistors as shown in Figure 5.19. In addition, when darlingtonts are used the turn-on supply may need to be increased in order to compensate for the additional voltage drop across the booster stage.

Figure 5.17 shows an example output waveform with a booster constructed using D44VH10/D45VH10. For this example, an output impedance of 1ohm was used to drive a capacitive load of 300nF. The circuit shown in Figure 5.18 shows the output booster being used with M57962L. This output booster stage can be used with M57958L if short circuit protection is not needed.

Figure 5.17 Output Waveform,
 $I_{OUT} = 5\text{A/div}$,
 $V_{OUT} = 5\text{V/div}$,
 $T = 1\mu\text{s/div}$

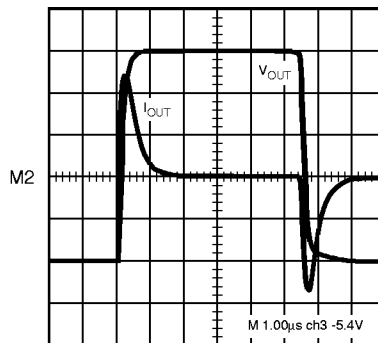
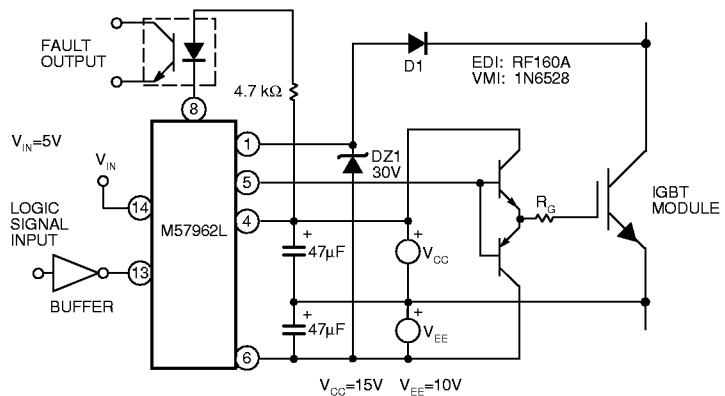

Figure 5.18 Example Circuit for Driving Large IGBT Modules



USING HYBRID GATE DRIVERS AND GATE DRIVE POWER SUPPLIES

Table 5.2 Booster Stage Transistors

| npn Transistor | pnp Transistor | Peak Current | V_{CEO} | Manufacturer | Package |
|----------------|----------------|--------------|-----------|--------------|-----------------|
| MJD44H11 | MJD45H11 | 15A | 80V | Motorola | Surface Mount |
| D44VH10 | D45VH10 | 20A | 80V | Motorola | TO-220 |
| MJE15030 | MJE15031 | 15A | 150V | Motorola | TO-220 |
| MJE243 | MJE253 | 8A | 100V | Motorola | TO-255 |
| 2SC4151 | 2SA1601 | 30A | 40V | Shindengen | Isolated TO-220 |

Figure 5.19 Alternate Booster Stage Configuration

