

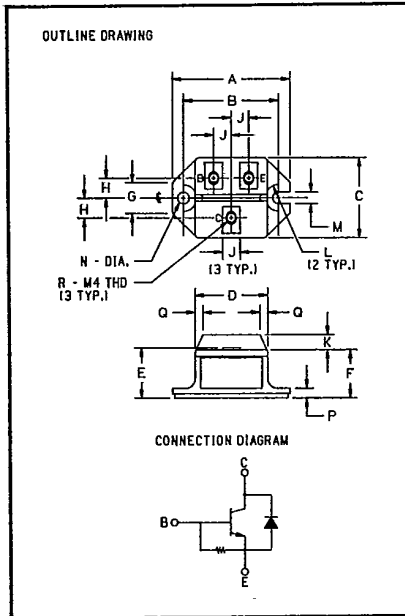

KS534505

Powerex, Inc., Hillis Street, Youngwood, Pennsylvania 15697 (412) 925-7272

Single Bipolar Transistor Module
50 Amperes/600 Volts



600 Volt KS534505
Outline Drawing

Dimension	Inches	Millimeters
A	2.106	53.5
B	1.705 ± .008	43.3 ± 0.2
C	1.437	36.5
D	1.299	33
E	.925	23.5
F	.866	22
G	.551	14
H	.354	9
J	.315	8
K	.276	7
L	.472 R	R6
M	.209	5.3
N	.209 Dia.	5.3 Dia.
P	.177	4.5
Q	.138	3.5
R	M4 Metric	M4

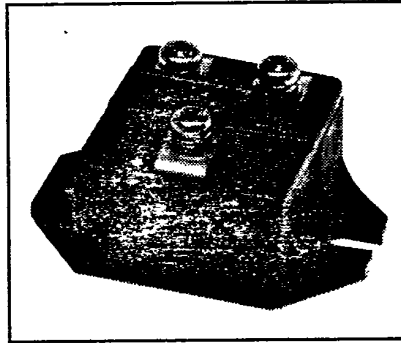

KS534505
Single Bipolar Transistor Module
 50 Amperes/600 Volts

Description

Powerex Single Bipolar Transistor Modules are designed for use in switching applications. The modules are isolated, consisting of one Bipolar Transistor having a reverse parallel connected high-speed diode.

Features:

- Isolated Mounting
- Planar Chips
- Discrete Fast Recovery Feed-Back Diode
- Low $V_{CE(SAT)}$
- Fast Switching

Applications:

- High Frequency Inverters
- AC & DC Motor Control
- Switching Power Supplies

Ordering Information

Example: Select the complete eight digit module part number you desire from the table - i.e. KS534505 is a 450 $V_{CE(SUS)}$ (600 V_{CEV}), 50 Ampere Single Bipolar Module.

Type	$V_{CE(SUS)}$ Volts ($\times 10$)	Current Rating Amperes ($\times 10$)
KS53	45	05



Powerex, Inc., Hillis Street, Youngwood, Pennsylvania 15697 (412) 925-7272

KS534505

Single Bipolar Transistor Module

50 Amperes/450 Volts

Maximum Ratings $T_J = 25^\circ\text{C}$ unless otherwise specified

	Symbol	KS534505	Units
Junction Temperature	T_J	-40 to 150	$^\circ\text{C}$
Storage Temperature	T_{STG}	-40 to 125	$^\circ\text{C}$
Collector-Emitter Sustaining Voltage	$V_{CEQ(SUS)}$	450	Volts
Collector-Emitter Sustaining Voltage $V_{BE} = -2\text{V}$	$V_{CEV(SUS)}$	600	Volts
Collector-Base Voltage	V_{CBO}	600	Volts
Emitter-Base Voltage	V_{EBO}	7	Volts
Collector-Emitter Voltage $V_{BE} = -2\text{V}$	V_{CEV}	600	Volts
Continuous Collector Current	I_C	50	Amperes
Diode Forward Current	I_{FM}	50	Amperes
Continuous Base Current	I_B	15	Amperes
Diode Surge Current	I_{FSM}	500	Amperes
Power Dissipation	P_T	310	Watts
Max. Mounting Torque M4 Terminal Screws	—	12	in.-lb.
Max. Mounting Torque M5 Mounting Screws	—	17	in.-lb.
Module Weight	—	90	Grams
V Isolation	V_{RMS}	2000	Volts



Powerex, Inc., Hillis Street, Youngwood, Pennsylvania 15697 (412) 925-7272

KS534505

Single Bipolar Transistor Module

50 Amperes/600 Volts

Electrical and Mechanical Characteristics $T_j = 25^\circ\text{C}$ unless otherwise specified

Characteristics	Symbol	Test Conditions	Min.	KS534505		Units
				Typ.	Max.	
Collector Cutoff Current	I_{CEV}	$V_{CE} = 600V, V_{BE} = -2V$	—	—	1	mA
Emitter Cutoff Current	I_{EBO}	$V_{EB} = 7V$	—	—	300	mA
DC Current Gain	h_{FE}	$I_C = 40A, V_{CE} = 5.0V$	8	—	—	—
DC Current Gain	h_{FE}	$I_C = 50A, V_{CE} = 2.0V$	—	12	—	—
Diode Forward Voltage	V_{FM}	$I_{FM} = 50A$	—	—	1.75	V
Collector-Emitter Saturation Voltage	$V_{CE(SAT)}$	$I_C = 50A, I_B = 10A$	—	—	1.0	V
Base-Emitter Saturation Voltage	$V_{BE(SAT)}$	$I_C = 50A, I_B = 10A$	—	—	1.5	V
Resistive Turn On	t_{on}	$V_{CC} = 300V$	—	—	2.0	μs
Load Storage Time	t_s	$I_C = 40A$	—	—	7	μs
Switch Times Fall Time	t_f	$I_{B1} = -I_{B2} = 8.0A$	—	—	1.0	μs
Thermal Resistance, Case to Sink Lubricated	$R_{\theta CS}$	—	—	—	.15	$^\circ\text{C/W}$
Thermal Resistance, Junction to Case	$R_{\theta JC}$	Transistor Part	—	—	0.4	$^\circ\text{C/W}$
Thermal Resistance, Junction to Case	$R_{\theta JC}$	Diode Part	—	—	1.3	$^\circ\text{C/W}$



Powerex, Inc., Hillis Street, Youngwood, Pennsylvania 15697 (412) 925-7272

KS534505
Single Bipolar Transistor Module
 50 Amperes/600 Volts

DC CURRENT GAIN (TYPICAL)

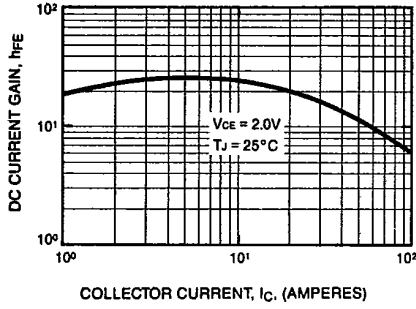

SATURATION VOLTAGE (TYPICAL)

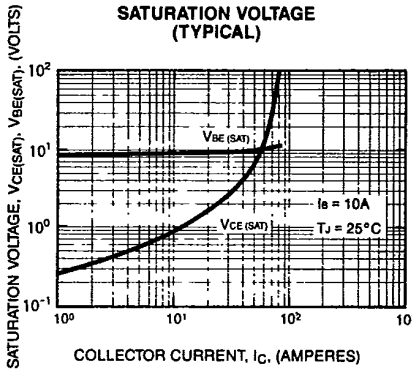

COMMON EMITTER OUTPUT CHARACTERISTICS (TYPICAL)

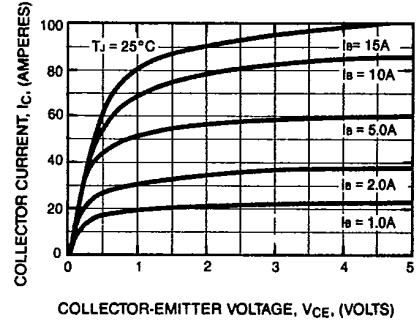

DIODE CHARACTERISTICS (TYPICAL)

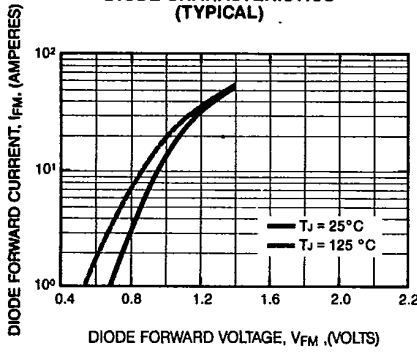

REVERSE RECOVERY CHARACTERISTICS OF FREE-WHEEL DIODE (TYPICAL)

