

FX3U SERIES PROGRAMMABLE CONTROLLERS

USER'S MANUAL

Hardware Edition

Main Unit

AC Power Type

FX3U-□MR/ES

FX3U-□MT/ES

FX3U-□MT/ESS

FX3U-□MS/ES

FX3U-□MR/UA1

DC Power Type

FX3U-□MR/DS

FX3U-□MT/DS

FX3U-□MT/DSS

**Input/Output Powered
Extension Unit**

FX2N-□E□-□

Input/Output Extension Block

FX2N-8E□-□

FX2N-16E□-□

Special Adapter

FX3U-4HSX-ADP

Display Module

FX3U-7DM

Memory Cassette



FX3U-FLROM-□



FX3U

Safety Precautions

(Read these precautions before use.)

Before installation, operation, maintenance or inspection of this product, thoroughly read through and understand this manual and all of the associated manuals. Also, take care to handle the module properly and safely.

This manual classifies the safety precautions into two categories:  **DANGER** and  **CAUTION**.

 DANGER	Indicates that incorrect handling may cause hazardous conditions, resulting in death or severe injury.
 CAUTION	Indicates that incorrect handling may cause hazardous conditions, resulting in medium or slight personal injury or physical damage.

Depending on the circumstances, procedures indicated by  **CAUTION** may also cause severe injury. It is important to follow all precautions for personal safety.

Store this manual in a safe place so that it can be taken out and read whenever necessary. Always forward it to the end user.

1. DESIGN PRECAUTIONS

 DANGER	Reference
<ul style="list-style-type: none"> • Make sure to have the following safety circuits outside of the PLC to ensure safe system operation even during external power supply problems or PLC failure. Otherwise, malfunctions may cause serious accidents. <ol style="list-style-type: none"> 1) Most importantly, have the following: an emergency stop circuit, a protection circuit, an interlock circuit for opposite movements (such as normal vs. reverse rotation), and an interlock circuit (to prevent damage to the equipment at the upper and lower positioning limits). 2) Note that when the PLC CPU detects an error, such as a watchdog timer error, during self-diagnosis, all outputs are turned off. Also, when an error that cannot be detected by the PLC CPU occurs in an input/output control block, output control may be disabled. External circuits and mechanisms should be designed to ensure safe machinery operation in such a case. 3) Note that the output current of the 24V DC service power supply varies depending on the model and the absence/presence of extension blocks. If an overload occurs, the voltage automatically drops, inputs in the PLC are disabled, and all outputs are turned off. External circuits and mechanisms should be designed to ensure safe machinery operation in such a case. 4) Note that when an error occurs in a relay, triac or transistor output device, the output could be held either on or off. For output signals that may lead to serious accidents, external circuits and mechanisms should be designed to ensure safe machinery operation in such a case. 	<ul style="list-style-type: none"> 141 166 186 229 249 291 314 354 439

 CAUTION	Reference
<ul style="list-style-type: none"> • Do not bundle the control line together with or lay it close to the main circuit or power line. As a guideline, lay the control line at least 100mm (3.94") or more away from the main circuit or power line. Noise may cause malfunctions. • Install module so that excessive force will not be applied to peripheral device connectors. Failure to do so may result in wire damage/breakage or PLC failure. 	<ul style="list-style-type: none"> 141 166 186 229 249 291 314 354 439

Safety Precautions

(Read these precautions before use.)

2. INSTALLATION PRECAUTIONS

DANGER	Reference
<ul style="list-style-type: none"> • Make sure to cut off all phases of the power supply externally before attempting installation or wiring work. Failure to do so may cause electric shock or damage to the product. 	141 439

CAUTION	Reference				
<ul style="list-style-type: none"> • Use the product within the generic environment specifications described in section 4.1 of this manual. Never use the product in areas with excessive dust, oily smoke, conductive dusts, corrosive gas (salt air, Cl₂, H₂S, SO₂ or NO₂), flammable gas, vibration or impacts, or expose it to high temperature, condensation, or rain and wind. If the product is used in such conditions, electric shock, fire, malfunctions, deterioration or damage may occur. • Do not touch the conductive parts of the product directly. Doing so may cause device failures or malfunctions. • Install the product securely using a DIN rail or mounting screws. <table border="1" style="width: 100%; border-collapse: collapse; margin-top: 5px;"> <tr> <td style="padding: 2px;">FX2N-10GM, FX2N-20GM, and terminal block</td> <td style="padding: 2px;">DIN rail only</td> </tr> <tr> <td style="padding: 2px;">Main unit, FX2N Series I/O extension unit/block, FX0N/FX2N/FX3U Series special function block, and special adapter</td> <td style="padding: 2px;">DIN rail or direct mounting</td> </tr> </table> • Install the product on a flat surface. If the mounting surface is rough, undue force will be applied to the PC board, thereby causing nonconformities. • Make sure to affix the expansion board with tapping screws. Tightening torque should follow the specifications in the manual. Loose connections may cause malfunctions. • When drilling screw holes or wiring, make sure that cutting and wiring debris do not enter the ventilation slits. Failure to do so may cause fire, equipment failures or malfunctions. • Be sure to remove the dust proof sheet from the PLC's ventilation port when installation work is completed. Failure to do so may cause fire, equipment failures or malfunctions. • Connect the extension cables, peripheral device cables, input/output cables and battery connecting cable securely to their designated connectors. Loose connections may cause malfunctions. • Connect the display module, memory cassette, and expansion board securely to their designated connectors. Loose connections may cause malfunctions. • Turn off the power to the PLC before attaching or detaching the following devices. Failure to do so may cause device failures or malfunctions. <ul style="list-style-type: none"> - Peripheral devices, display modules, expansion boards and special adapters - Extension units/blocks and FX Series terminal blocks - Battery and memory cassette • Connect the memory cassette securely to the appropriate connector. Loose connections may cause malfunctions. Installing the cassette in a raised or tilted posture can also cause malfunctions. Cross-sectional drawing (memory cassette installation position) <div style="margin-top: 10px;"> <p style="text-align: center;">Cross-section drawing (memory cassette installation condition)</p> <p style="text-align: center;">Press the 4 corners in approx. 0.4mm(0.02")</p> </div> 	FX2N-10GM, FX2N-20GM, and terminal block	DIN rail only	Main unit, FX2N Series I/O extension unit/block, FX0N/FX2N/FX3U Series special function block, and special adapter	DIN rail or direct mounting	142 440 463
FX2N-10GM, FX2N-20GM, and terminal block	DIN rail only				
Main unit, FX2N Series I/O extension unit/block, FX0N/FX2N/FX3U Series special function block, and special adapter	DIN rail or direct mounting				

Safety Precautions

(Read these precautions before use.)

3. WIRING PRECAUTIONS

 DANGER	Reference
<ul style="list-style-type: none"> • Make sure to cut off all phases of the power supply externally before attempting installation or wiring work. Failure to do so may cause electric shock or damage to the product. • Make sure to attach the terminal cover, offered as an accessory, before turning on the power or initiating operation after installation or wiring work. Failure to do so may cause electric shock. 	<p>142 166 169 173 186 229 249 291 314 440</p>

 CAUTION	Reference
<ul style="list-style-type: none"> • Do not supply power to the [24+] and [24V] terminals (24V DC service power supply) on the main unit or extension units. Doing so may cause damage to the product. • Perform class D grounding (grounding resistance: 100 Ω or less) to the grounding terminal on the main unit and extension units with a wire 2 mm² or thicker. Do not use common grounding with heavy electrical systems (refer to Section 9.4). • Connect the AC power supply wiring to the dedicated terminals described in this manual. If an AC power supply is connected to a DC input/output terminal or DC power supply terminal, the PLC will burn out. • Connect the DC power supply wiring to the dedicated terminals described in this manual. If an AC power supply is connected to a DC input/output terminal or DC power supply terminal, the PLC will burn out. • Do not wire vacant terminals externally. Doing so may damage the product. • When drilling screw holes or wiring, make sure that cutting and wiring debris do not enter the ventilation slits. Failure to do so may cause fire, equipment failures or malfunctions. • Make sure to properly wire the FX3U Series main unit and FX0N/FX2N/FX3U Series extension equipment in accordance with the following precautions. Failure to do so may cause electric shock, equipment failures, a short-circuit, wire breakage, malfunctions, or damage to the product. <ul style="list-style-type: none"> - The disposal size of the cable end should follow the dimensions described in the manual. - Tightening torque should follow the specifications in the manual. • Make sure to properly wire to the terminal block (European type) in accordance with the following precautions. Failure to do so may cause electric shock, equipment failures, a short-circuit, wire breakage, malfunctions, or damage to the product. <ul style="list-style-type: none"> - The disposal size of the cable end should follow the dimensions described in the manual. - Tightening torque should follow the specifications in the manual. - Twist the end of strand wire and make sure that there are no loose wires. - Do not solder-plate the electric wire ends. - Do not connect more than the specified number of wires or electric wires of unspecified size. - Affix the electric wires so that neither the terminal block nor the connected parts are directly stressed. • Make sure to properly wire to the FX Series terminal blocks in accordance with the following precautions. Failure to do so may cause electric shock, equipment failures, a short-circuit, wire breakage, malfunctions, or damage to the product. <ul style="list-style-type: none"> - The disposal size of the cable end should follow the dimensions described in the manual. - Tightening torque should follow the specifications in the manual. 	<p>143 167 169 173 187 230 235 243 244 248 250 292 314 440 449</p>

Safety Precautions

(Read these precautions before use.)

4. STARTUP AND MAINTENANCE PRECAUTIONS

 DANGER	Reference
<ul style="list-style-type: none"> • Do not touch any terminal while the PLC's power is on. Doing so may cause electric shock or malfunctions. • Before cleaning or retightening terminals, cut off all phases of the power supply externally. Failure to do so may cause electric shock. • Use the battery for memory backup correctly in conformance to this manual. <ul style="list-style-type: none"> - Use the battery only for the specified purpose. - Connect the battery correctly. - Do not charge, disassemble, heat, put in fire, short-circuit, connect reversely, weld, swallow or burn the battery, or apply excessive forces (vibration, impact, drop, etc.) to the battery. - Do not store or use the battery at high temperatures or expose to direct sunlight. - Do not expose to water, bring near fire or touch liquid leakage or other contents directly. - Incorrect handling of the battery may cause heat excessive generation, bursting, ignition, liquid leakage or deformation, and lead to injury, fire or failures and malfunctions of facilities and other equipment. • Before modifying or disrupting the program in operation or running the PLC, carefully read through this manual and the associated manuals and ensure the safety of the operation. An operation error may damage the machinery or cause accidents. • Do not change the program in the PLC from two or more peripheral equipment devices at the same time. (i.e. from a programming tool and a GOT) Doing so may cause destruction or malfunction of the PLC program. 	266 381 469

 CAUTION	Reference
<ul style="list-style-type: none"> • Turn off the power to the PLC before attaching or detaching the memory cassette. If the memory cassette is attached or detached while the PLC's power is on, the data in the memory may be destroyed, or the memory cassette may be damaged. • Do not disassemble or modify the PLC. Doing so may cause fire, equipment failures, or malfunctions. For repair, contact your local Mitsubishi Electric representative. • Turn off the power to the PLC before connecting or disconnecting any extension cable. Failure to do so may cause equipment failures or malfunctions. • Turn off the power to the PLC before attaching or detaching the following devices. Failure to do so may cause equipment failures or malfunctions. <ul style="list-style-type: none"> - Peripheral devices, display module, expansion boards, and special adapters - Extension units/blocks and FX Series terminal blocks - Battery and memory cassette 	266 381 462 469

5. DISPOSAL PRECAUTIONS

 CAUTION	Reference
<ul style="list-style-type: none"> • Please contact a certified electronic waste disposal company for the environmentally safe recycling and disposal of your device. When disposing of batteries, separate them from other waste according to local regulations. (For details of the Battery Directive in EU countries, refer to Appendix F) 	266

Safety Precautions

(Read these precautions before use.)

6. TRANSPORTATION AND STORAGE PRECAUTIONS

 CAUTION	Reference
<ul style="list-style-type: none">• Before transporting the PLC, turn on the power to the PLC to check that the BATT LED is off. If the PLC is transported with the BATT LED on or the battery exhausted, the battery-backed data may be unstable during transportation.• The PLC is a precision instrument. During transportation, avoid impacts larger than those specified in the general specifications (section 4.1). Failure to do so may cause failures in the PLC. After transportation, verify the operations of the PLC.• When transporting lithium batteries, follow required transportation regulations. (For details of the regulated products, refer to Appendix E)	267 469

Safety Precautions

(Read these precautions before use.)

MEMO

FX3U Series Programmable Controllers

User's Manual [Hardware Edition]

Manual number	JY997D16501
Manual revision	L
Date	3/2012

Foreword

This manual contains text, diagrams and explanations which will guide the reader in the correct installation, safe use and operation of the FX3U Series Programmable Controllers and should be read and understood before attempting to install or use the unit.

And, store this manual in a safe place so that you can take it out and read it whenever necessary. Always forward it to the end user.

This manual confers no industrial property rights or any rights of any other kind, nor does it confer any patent licenses. Mitsubishi Electric Corporation cannot be held responsible for any problems involving industrial property rights which may occur as a result of using the contents noted in this manual.

Outline Precautions

- This manual provides information for the use of the FX3u Series Programmable Controllers. The manual has been written to be used by trained and competent personnel. The definition of such a person or persons is as follows;
 - 1) Any engineer who is responsible for the planning, design and construction of automatic equipment using the product associated with this manual should be of a competent nature, trained and qualified to the local and national standards required to fulfill that role. These engineers should be fully aware of all aspects of safety with regards to automated equipment.
 - 2) Any commissioning or service engineer must be of a competent nature, trained and qualified to the local and national standards required to fulfill that job. These engineers should also be trained in the use and maintenance of the completed product. This includes being completely familiar with all associated documentation for the said product. All maintenance should be carried out according to established safety practices.
 - 3) All operators of the completed equipment should be trained to use that product in a safe and coordinated manner in compliance to established safety practices. The operators should also be familiar with documentation which is connected with the actual operation of the completed equipment.
- **Note:** The term 'completed equipment' refers to a third party constructed device which contains or uses the product associated with this manual
- This product has been manufactured as a general-purpose part for general industries, and has not been designed or manufactured to be incorporated in a device or system used in purposes related to human life.
- Before using the product for special purposes such as nuclear power, electric power, aerospace, medicine or passenger movement vehicles, consult with Mitsubishi Electric.
- This product has been manufactured under strict quality control. However when installing the product where major accidents or losses could occur if the product fails, install appropriate backup or failsafe functions in the system.
- When combining this product with other products, please confirm the standard and the code, or regulations with which the user should follow. Moreover, please confirm the compatibility of this product to the system, machine, and apparatus with which a user is using.
- If in doubt at any stage during the installation of the product, always consult a professional electrical engineer who is qualified and trained to the local and national standards. If in doubt about the operation or use, please consult the nearest Mitsubishi Electric representative.
- Since the examples indicated by this manual, technical bulletin, catalog, etc. are used as a reference, please use it after confirming the function and safety of the equipment and system. Mitsubishi Electric will accept no responsibility for actual use of the product based on these illustrative examples.
- This manual content, specification etc. may be changed without a notice for improvement.
- The information in this manual has been carefully checked and is believed to be accurate; however, if you have noticed a doubtful point, a doubtful error, etc., please contact the nearest Mitsubishi Electric representative.

Registration

- Microsoft® and Windows® are either registered trademarks or trademarks of Microsoft Corporation in the United States and/or other countries.
- The company name and the product name to be described in this manual are the registered trademarks or trademarks of each company.

Table of Contents

SAFETY PRECAUTIONS (1)

Standards	15
Certification of UL, cUL standards	15
Compliance with EC directive (CE Marking)	16
Requirement for Compliance with EMC directive	16
Requirement for Compliance with LVD directive	19
Caution for compliance with EC Directive	20
1. Introduction	21
1.1 Introduction of Manuals	21
1.1.1 Classification of major components in this manual	21
1.1.2 Manual organization and position of this manual	23
1.1.3 List of manuals	24
1.2 Generic Names and Abbreviations Used in Manuals	31
2. Features and Part Names	34
2.1 Major Features	34
2.2 Names and Functions of Parts	36
2.2.1 Front Panel	36
2.2.2 Sides	38
3. Introduction of Products (Compliant with Overseas Standards)	39
3.1 List of Products (to be Connected) and Interpretation of Model Names	39
3.1.1 [A] Main units	40
3.1.2 [B] Input/output powered extension units	41
3.1.3 [C] Input/output extension blocks	42
3.1.4 [D] [E] Special function units/blocks	43
3.1.5 [F] Display modules and holder	45
3.1.6 [G] Expansion boards	45
3.1.7 [H] Special adapters	46
3.1.8 [I] Extension power supply unit	47
3.1.9 [J] Extension cables and connector conversion adapter [K] Battery [L] Memory cassettes	47
3.1.10 [M] FX Series terminal blocks (cables and connectors)	48
3.1.11 [N] Remote I/O	48
3.1.12 [O] Power supply unit	48
3.2 Connector Types and Cables for Program Communication	49
3.2.1 Programming tool	50
3.2.2 Communication cables	50
3.2.3 Converters and interface	51
4. Specifications, External Dimensions and Terminal Layout (Main Units)	52
4.1 Generic Specifications	52
4.1.1 Dielectric withstand voltage test and insulation resistance test	53
4.2 Power Supply Specifications	54
4.2.1 AC Power Supply/DC Input Type	54
4.2.2 DC Power Supply/DC Input Type	55
4.2.3 AC Power Supply/AC Input Type	55

4.3	Input Specifications	56
4.3.1	24V DC input (sink/source) type	56
4.3.2	100V AC input type	57
4.4	Output Specifications	58
4.4.1	Relay output type	58
4.4.2	Product life of relay contacts	59
4.4.3	Transistor output (sink) type	60
4.4.4	Transistor output (source) type	61
4.4.5	Triac output type	62
4.5	Performance Specifications	63
4.6	External Dimensions (Weight and Installation)	66
4.6.1	FX3U-16M□, FX3U-32M□	66
4.6.2	FX3U-48M□, FX3U-64M□, FX3U-80M□, FX3U-128M□	67
4.7	Terminal Layout	68
4.7.1	Interpretation	68
4.7.2	FX3U-16M□	69
4.7.3	FX3U-32M□	70
4.7.4	FX3U-48M□	71
4.7.5	FX3U-64M□	72
4.7.6	FX3U-80M□	73
4.7.7	FX3U-128M□	74

5. Version Information and Peripheral Equipment Connectability **75**

5.1	Version Upgrade History	75
5.1.1	How to look at manufacturer's serial number	75
5.1.2	Version check method	76
5.1.3	Version upgrade history	76
5.2	Programming Tool Applicability	77
5.2.1	Applicable versions of programming tool	77
5.2.2	In case of programming tool (version) not applicable	78
5.2.3	Program transfer speed and programming tools	78
5.2.4	Cautions on connecting peripheral equipment by way of expansion board or special adapter	79
5.2.5	Cautions on write during RUN	80
5.3	Cautions on using transparent function by way of USB in GOT1000 Series	84
5.4	Cautions on using transparent port (2-port) function of GOT-F900 Series	85
5.5	Other Peripheral Equipment Applicability	86
5.5.1	Other Peripheral Equipment Applicability	86

6. Examination of System Configuration **87**

6.1	Configuration of a Whole System	87
6.1.1	List of system components	88
6.1.2	System configuration with special adapters	90
6.2	Rules of System Configuration	91
6.3	Number of Input/Output Points and Maximum Number of Input/Output Points	93
6.3.1	Calculation of number of input/output points	93
6.3.2	Maximum number of input/output points when CC-Link master is used	95
6.3.3	Maximum number of input/output points when AS-i master is used	96
6.4	Number of Connected Special Extension Devices (Including Extension Cable)	97
6.4.1	Expansion board and special adapter	97
6.4.2	Special function units/blocks, High-speed input/output special adapter	97
6.4.3	Extension cable	97

6.5	Expansion of Main Unit (Calculation of Current Consumption).....	98
6.5.1	Quick reference matrix - when only input/output devices are added (AC Power Supply/DC Input Type).....	98
6.5.2	When special extension devices are also added [calculation of current consumption] (AC Power Supply/DC Input Type).....	100
6.5.3	Quick reference matrix [when only input/output devices are added] (DC Power Type).....	103
6.5.4	When special extension devices are also added [calculation of current consumption] (DC Power Type).....	104
6.5.5	Quick reference matrix [when only input/output devices are added] (AC Power Supply/AC Input Type).....	107
6.5.6	When special extension devices are also added [calculation of current consumption] (AC Power Supply/AC Input Type).....	108
6.6	Expansion of FX2N Series I/O Powered Extension Unit (Calculation of Current Consumption).....	111
6.6.1	Quick reference matrix (when only input/output devices are added).....	111
6.6.2	When special extension devices are also added (calculation of current consumption).....	114
6.7	Expansion of Extension Power Supply Unit (FX3U-1PSU-5V).....	116
6.8	Number of Input/Output (Occupied) Points and Current Consumption.....	119
6.8.1	[A] Main units.....	120
6.8.2	[B] Expansion boards.....	122
6.8.3	[C] Special adapters.....	122
6.8.4	[D] Input/output powered extension units/blocks.....	123
6.8.5	[E] Special extension devices.....	124
6.8.6	[G] Display module.....	125
6.8.7	[H] Extension power supply unit.....	125
6.9	Example of System Configuration and System Modification.....	126
6.9.1	Example system configuration.....	126
6.9.2	Expansion of main unit.....	127
6.9.3	Re-examination of suitability for configuration.....	130

7. Assignment of Input/Output Numbers (X/Y) and Unit Numbers **135**

7.1	Assignment of Input/Output Numbers (X/Y).....	135
7.1.1	Concept of assigning.....	135
7.1.2	Example of assigning.....	136
7.1.3	Application of I/O number label.....	137
7.2	Unit Numbers of Special Function Units/Blocks.....	138
7.2.1	Concept of assigning.....	138
7.2.2	Example of assigning.....	139
7.2.3	Application of unit number labels.....	140
7.3	Application of the trimmer layout label.....	140

8. Installation In Enclosure **141**

8.1	Generic Specifications.....	144
8.2	Installation location.....	145
8.2.1	Installation location in enclosure.....	145
8.2.2	Spaces in enclosure.....	146
8.3	Layout in Enclosure.....	147
8.3.1	1-stage layout.....	147
8.3.2	2-stage layout.....	147
8.4	Examination for Installing Method in Enclosure.....	149
8.4.1	Installing methods.....	149
8.4.2	Cautions on examining installing method.....	149
8.4.3	Examples of installation.....	149
8.5	Procedures for Installing on and Detaching from DIN Rail.....	151
8.5.1	Preparation for installation.....	151
8.5.2	Installation of main unit.....	152
8.5.3	Installation of input/output powered extension unit/block and special function unit/block.....	153
8.5.4	Removal of main unit.....	153

8.6	Procedures for Installing Directly (with M4 Screws)	155
8.6.1	Hole pitches for direct mounting	155
8.6.2	Example of mounting hole pitches	158
8.6.3	Installation of main unit	159
8.6.4	Installation of input/output powered extension unit/block and special function unit/block	159
8.7	Connecting Methods for Main Unit and Extension Devices	160
8.7.1	Connection of extension devices	160
8.7.2	Connecting method A - connection of expansion board	161
8.7.3	Connecting method B - connection of special adapter	162
8.7.4	Connecting method C - connection of powered extension unit/block to main unit	162
8.7.5	Connecting method D - connection of powered extension units/blocks	163
8.7.6	Connecting method E - connection of extension cable and FX2N-CNV-BC	164
8.7.7	Connecting method F - connection of input/output powered extension unit	164
8.7.8	Connecting method G - connection of extension block to input/output powered extension unit	165

9. Preparation for Wiring and Power Supply Wiring Procedures 166

9.1	Preparation for Wiring	168
9.1.1	Wiring procedures	168
9.1.2	Removal and installation of quick-release terminal block (Except for the FX3U-16M□)	168
9.2	Cable Connecting Procedures	169
9.2.1	Input/output terminal block (power supply and input/output wiring)	169
9.2.2	Input/output connectors	172
9.2.3	Terminal block (for europe) [expansion board and special adapters]	173
9.3	Power Supply Specifications	175
9.3.1	AC Power Supply Type	175
9.3.2	DC Power Supply Type	176
9.4	Grounding	177
9.5	Examples of External Wiring [AC Power Supply/DC Input Type]	178
9.5.1	Example of input/output wiring with 24V DC service power supply	178
9.5.2	Example of sink input [-common] wiring	179
9.5.3	Example of source input [+common] wiring	180
9.5.4	An external wiring example for the extension power supply unit (sink input [-common])	181
9.5.5	An external wiring example for the extension power supply unit (source input [+common])	182
9.6	Examples of External Wiring [DC Power Supply/DC Input Type]	183
9.6.1	Example of sink input [-common] wiring	183
9.6.2	Example of source input [+common] wiring	184
9.7	Examples of External Wiring [AC Power Supply/AC Input Type]	185
9.7.1	Example of AC input wiring	185

10. Input Wiring Procedures (Input Interruption and Pulse Catch) 186

10.1	Before Starting Input Wiring	188
10.1.1	Sink and source input (24V DC input type)	188
10.2	24V DC Input Type (Common to Sink/Source Input)	189
10.2.1	Input specifications (main unit)	189
10.2.2	Handling of 24V DC input	190
10.2.3	Instructions for connecting input devices	191
10.2.4	Examples of external wiring (sink input) [AC Power Supply Type]	193
10.2.5	Example of external wiring (source input) [AC Power Supply Type]	195
10.2.6	Examples of external wiring (sink input) [DC power supply type]	196
10.2.7	Example of external wiring (source input) [DC Power Supply Type]	198
10.3	100V AC Input Type	199
10.3.1	Input specifications (main unit)	199
10.3.2	Handling of 100V AC Input	200
10.3.3	Example of external wiring	201
10.4	Input Interruption (I00□ to I50□) - With Delay Function	202
10.4.1	Allocation of pointers to input numbers (input signal ON/OFF duration)	202
10.4.2	Input interruption delay function	202
10.4.3	Cautions for input interruption	202
10.4.4	Examples of external wiring	203

10.5 Pulse Catch (M8170 to M8177)	204
10.5.1 Allocation of special memories to input numbers (ON duration of input signals)	204
10.5.2 Cautions for pulse catch	204
10.5.3 Examples of external wiring	205

11. Use of High-speed Counters (C235 to C255) 206

11.1 Outline	206
11.2 Input Specifications	207
11.2.1 High-speed input special adapter (FX3U-4HSX-ADP)	207
11.2.2 Cautions on connecting mating device	207
11.3 Types of Counting and Operations	208
11.3.1 Classification according to counting method	208
11.3.2 Types and input signal forms	208
11.3.3 High-speed counter device notations	208
11.4 List of Device Numbers and Functions	209
11.5 Allocation of Device Numbers to Input Numbers	211
11.5.1 Allocation table	211
11.5.2 Inhibition of redundant use of input numbers	212
11.6 Handling of High-speed Counters	213
11.6.1 1-phase 1-count input	213
11.6.2 1-phase 2-count input	214
11.6.3 2-phase 2-count input	215
11.7 Timing of Updating of Current Value and Comparison of Current Value	216
11.7.1 Timing of updating of current value	216
11.7.2 Comparison of current value	216
11.8 Conditions for Hardware Counter to be Handled as Software Counter	217
11.8.1 Conditions under which counters are handled as software counters	217
11.8.2 Method of confirming operation status of counters	217
11.9 Calculation of Response Frequency and Overall Frequency	218
11.9.1 Response frequencies of hardware counters	218
11.9.2 Response frequencies and overall frequency of software counters	218
11.10 Examples of External Wiring (Rotary Encoder)	221
11.10.1 1-phase 1-input [C235 to C245]	221
11.10.2 2-phase 2-input [C251 to C255]	222
11.10.3 Cautions for the other side device	223
11.11 Related Devices and Function Switching Procedures	224
11.11.1 Related devices	224
11.11.2 [Function switching] switching of logic of external reset input signal	226
11.11.3 [Function switching] switching of allocation and functions of input terminals	226
11.11.4 [Function switching] procedures for using 2-phase 2-count input counters C251 to C255 in 4 edge count mode	227
11.12 Cautions on Use	228

12. Output Wiring Procedures 229

12.1 Sink and Source Output (Transistor)	231
12.2 External Wiring for Relay Output	232
12.2.1 Output specifications (main unit) relay output	232
12.2.2 Product life of relay contacts	233
12.2.3 Handling of relay output	233
12.2.4 External wiring precautions	234
12.2.5 Example of external wiring	235
12.3 External Wiring of Transistor Output (Sink/Source) Type	236
12.3.1 Output specifications (main unit) transistor output (sink) type	237
12.3.2 Output specifications (main unit) transistor output (source) type	238
12.3.3 Handling of transistor output	239
12.3.4 External wiring precautions	241
12.3.5 Example of external wiring	243
12.4 External Wiring for Triac (SSR) Output Type	245
12.4.1 Output specification (main unit) triac output type	245
12.4.2 Handling of triac output	246
12.4.3 External wiring precautions	247
12.4.4 Example of external wiring	248

13. Examples of Wiring for Various Uses	249
13.1 Notes about Examples of Wiring	250
13.2 Digital Switch [DSW Instruction (FNC 72)/BIN Instruction (FNC 19)]	251
13.2.1 When DSW instructions are used	251
13.2.2 When BIN instructions are used	254
13.3 Ten Key Input [TKY Instruction (FNC 70)]	255
13.4 Hexadecimal Input [HKY Instruction (FNC 71)]	256
13.5 Input Matrix [MTR Instruction (FNC 52)]	259
13.6 Seven Segment with Latch [SEGL Instruction (FNC 74)/BCD Instruction (FNC 18)]	262
13.6.1 When SEGL instructions are used	262
13.6.2 When BCD instructions are used	264
14. Test Operation, Adjustment, Maintenance and Troubleshooting	266
14.1 Preparation for Test Operation	267
14.1.1 Preliminary inspection [power OFF]	267
14.1.2 Connection to built-in programming connector	267
14.1.3 Writing of program and program check [power ON and PLC stopped]	268
14.2 Running and Stopping Procedures [Power ON]	269
14.2.1 Methods of running and stopping	269
14.2.2 Use of several running/stopping methods	270
14.3 Operation and Test [Power ON and PLC Running]	271
14.3.1 Self-diagnostic function	271
14.3.2 Test functions	271
14.3.3 Program modification function	272
14.4 Maintenance and Periodic Inspection	273
14.4.1 Procedures for checking model name	273
14.4.2 Periodic inspection - battery life, etc.	273
14.4.3 Maintenance - product life of relay contacts	274
14.4.4 Procedures for replacing battery	275
14.5 Troubleshooting with LEDs	276
14.5.1 POWER LED [on/flashing/off]	276
14.5.2 BATT LED [on/off]	276
14.5.3 ERROR LED [on/flashing/off]	277
14.6 Judgment by Error Codes and Representation of Error Codes	278
14.6.1 Operation and check on display module (FX3U-7DM)	278
14.6.2 Operation and check by GX developer	279
14.6.3 Representation of errors	280
14.6.4 Error Code List and Action	281
14.7 Troubleshooting	289
14.7.1 Output does not operate (main unit and input/output extension blocks)	289
14.7.2 24V DC input does not operate (main unit and input/output extension blocks)	289
14.7.3 Cautions on registering a keyword	290
14.7.4 Cautions on using block password	290
15. FX2N-32/48E*-* (Input/Output Powered Extension Units)	291
15.1 Outline	293
15.1.1 Product configuration	293
15.1.2 Product list	293
15.2 Power Supply Specifications (Power Supply Input/24V DC Service Power Supply)	294
15.2.1 Weight, accessories, etc.	294
15.2.2 Part names	295
15.3 FX2N-32ER-ES/UL, FX2N-48ER-ES/UL, FX2N-48ER-DS	297
15.3.1 Product specifications	297
15.3.2 External dimensions	298
15.3.3 Terminal layout	299
15.4 FX2N-32ET-ESS/UL, FX2N-48ET-ESS/UL, FX2N-48ET-DSS	300
15.4.1 Product specifications	300
15.4.2 External dimensions	301
15.4.3 Terminal layout	302

15.5 FX2N-32ER, FX2N-48ER, FX2N-48ER-D.....	303
15.5.1 Product specifications.....	303
15.5.2 External dimensions.....	304
15.5.3 Terminal layout.....	305
15.6 FX2N-32ET, FX2N-48ET, FX2N-48ET-D.....	306
15.6.1 Product specifications.....	306
15.6.2 External dimensions.....	307
15.6.3 Terminal layout.....	308
15.7 FX2N-32ES.....	309
15.7.1 Product specifications.....	309
15.7.2 External dimensions.....	310
15.7.3 Terminal layout.....	310
15.8 FX2N-48ER-UA1/UL.....	311
15.8.1 Product specifications.....	311
15.8.2 External dimensions.....	312
15.8.3 Terminal layout.....	313

16. FX2N-8/16E*-(Input/Output Extension Blocks) 314

16.1 Outline.....	315
16.1.1 Product type.....	315
16.1.2 List of products.....	316
16.2 FX2N-8ER-ES/UL (24V DC Sink/Source Input, Relay Output).....	318
16.2.1 Product specifications.....	318
16.2.2 Parts identification and terminal arrangement.....	319
16.2.3 External dimensions.....	320
16.3 FX2N-8ER (24V DC Sink Input, Relay Output).....	321
16.3.1 Product specifications.....	321
16.3.2 Parts identification and terminal arrangement.....	322
16.3.3 External dimensions.....	323
16.4 FX2N-8EX-ES/UL, FX2N-16EX-ES/UL (24V DC Sink/Source Input).....	324
16.4.1 Product specifications.....	324
16.4.2 Parts identification and terminal arrangement.....	325
16.4.3 External dimensions.....	326
16.5 FX2N-8EX, FX2N-16EX and FX2N-16EX-C.....	327
16.5.1 Product specifications.....	327
16.5.2 Parts identification and terminal arrangement.....	328
16.5.3 External dimensions.....	329
16.6 FX2N-16EXL-C (5V DC Input: 16 Points).....	331
16.6.1 Product specifications.....	331
16.6.2 Parts identification and terminal arrangement.....	332
16.6.3 External dimensions.....	332
16.6.4 Example of wiring.....	332
16.7 FX2N-8EX-UA1/UL (100V AC Input).....	334
16.7.1 Product specifications.....	334
16.7.2 Parts identification and terminal arrangement.....	335
16.7.3 External dimensions.....	335
16.8 FX2N-8EYR-ES/UL, FX2N-8EYR-S-ES/UL, FX2N-16EYR-ES/UL (Relay Output).....	336
16.8.1 Product specifications.....	336
16.8.2 Parts identification and terminal arrangement.....	337
16.8.3 External dimensions.....	339
16.9 FX2N-8EYT-ESS/UL, FX2N-16EYT-ESS/UL (Transistor Output).....	340
16.9.1 Product specifications.....	340
16.9.2 Parts identification and terminal arrangement.....	341
16.9.3 External dimensions.....	342
16.10 FX2N-8EYR, FX2N-16EYR (Relay Output).....	343
16.10.1 Product specifications.....	343
16.10.2 Parts identification and terminal arrangement.....	344
16.10.3 External dimensions.....	345

16.11 FX2N-8EYT, FX2N-16EYT and FX2N-16EYT-C (Transistor Output)	346
16.11.1 Product specifications	346
16.11.2 Parts identification and terminal arrangement	347
16.11.3 External dimensions	348
16.12 FX2N-8EYT-H (Transistor Output)	350
16.12.1 Product specifications	350
16.12.2 Parts identification and terminal arrangement	351
16.12.3 External dimensions	351
16.13 FX2N-16EYS (Triac Output: 16 Points)	352
16.13.1 Product specifications	352
16.13.2 Parts identification and terminal arrangement	353
16.13.3 External dimensions	353

17. FX3U-1PSU-5V (Extension Power Supply Unit) 354

17.1 Introduction	354
17.2 Specifications	355
17.2.1 Generic Specifications	355
17.2.2 Performance Specifications	355
17.2.3 External Dimensions	355
17.3 Extension Power Supply Unit Related Precaution	355

18. Other Extension Devices and Optional Units (External Dimensions and Terminal Arrangement) 356

18.1 Special Function Units/Blocks	356
18.1.1 FX0N-3A	356
18.1.2 FX2N-2AD	356
18.1.3 FX2N-2DA	357
18.1.4 FX3U-4AD	357
18.1.5 FX3U-4DA	358
18.1.6 FX2N-4AD	358
18.1.7 FX2N-4DA	359
18.1.8 FX2N-4AD-PT	359
18.1.9 FX2N-4AD-TC	360
18.1.10 FX2N-5A	360
18.1.11 FX3U-4LC	361
18.1.12 FX2N-2LC	361
18.1.13 FX2N-8AD	362
18.1.14 FX3U-2HC	362
18.1.15 FX2N-1HC	363
18.1.16 FX3U-20SSC-H	363
18.1.17 FX2N-1PG(-E)	364
18.1.18 FX2N-10PG	364
18.1.19 FX2N-10GM	365
18.1.20 FX2N-20GM	365
18.1.21 FX2N-1RM(-E)-SET	366
18.1.22 FX2N-232IF	367
18.1.23 FX2N-32ASI-M	367
18.1.24 FX2N-64CL-M	368
18.1.25 FX3U-16CCL-M	368
18.1.26 FX2N-16CCL-M	369
18.1.27 FX2N-32CCL	369
18.1.28 FX3U-64CCL	370
18.1.29 FX2N-16LNK-M	370
18.2 Extension Power Supply Unit	371
18.2.1 FX3U-1PSU-5V	371

18.3	Special Adapters	371
18.3.1	FX3U-4AD-ADP	371
18.3.2	FX3U-4DA-ADP	372
18.3.3	FX3U-3A-ADP	372
18.3.4	FX3U-4AD-PT(W)-ADP	372
18.3.5	FX3U-4AD-PNK-ADP	373
18.3.6	FX3U-4AD-TC-ADP	373
18.3.7	FX3U-232ADP(-MB)	374
18.3.8	FX3U-485ADP(-MB)	374
18.3.9	FX3U-CF-ADP	375
18.3.10	FX3U-4HSX-ADP	375
18.3.11	FX3U-2HSY-ADP	375
18.4	Expansion Board	376
18.4.1	FX3U-USB-BD	376
18.4.2	FX3U-232-BD	376
18.4.3	FX3U-422-BD	376
18.4.4	FX3U-485-BD	377
18.4.5	FX3U-8AV-BD	377
18.4.6	FX3U-CNV-BD	377
18.5	Power Supply	378
18.5.1	FX2N-20PSU	378
18.6	Connector Conversion Adapter	378
18.6.1	FX2N-CNV-BC	378
18.7	Interface Module	379
18.7.1	FX-232AWC-H	379
18.7.2	FX-USB-AW	379
18.8	Display Module	380
18.8.1	FX3U-7DM	380
18.8.2	FX3U-7DM-HLD	380

19. FX3U-7DM (Display Module)	381
--------------------------------------	------------

19.1	Description of Products (Introduction of Related Products)	382
19.2	Specifications	383
19.2.1	Display/switch specifications	383
19.2.2	Parts layout	383
19.2.3	External dimensions	383
19.3	Installation and Removal	384
19.4	Summary of Functions	385
19.5	Procedure for Accessing the Menu Screen from the Title Screen	386
19.5.1	Title screen	386
19.5.2	Top screen (time display)	386
19.5.3	Menu screen	386
19.6	Menu Structure	387
19.7	Monitor/Test Mode [Excluding User-Registered Devices]	389
19.7.1	Relevant devices	389
19.7.2	Monitor mode operation	390
19.7.3	Monitor screen & status display	391
19.7.4	Test mode operation	393
19.7.5	Test mode operation notes	396
19.8	Monitor/Test Mode [User-Registered Devices]	397
19.8.1	Monitor mode operation	397
19.8.2	Test mode operation	398
19.9	Error Check	398
19.10	LANGUAGE (Menu Display Language Setting)	399
19.10.1	Changing to Japanese menus	399
19.10.2	Changing to English menus	400
19.10.3	D8302 changes by program & related devices	400
19.11	Contrast	401
19.12	Clock Menu (Current Time Setting)	402
19.12.1	Current time setting procedure	402
19.12.2	Displaying the current time	403
19.12.3	Changing the current time's "Year" from 2-digit format to 4-digit format	403

19.13	Keyword (Entry code).....	404
19.13.1	Keyword (Entry code) types & levels.....	404
19.13.2	Level-specific restrictions screen list.....	405
19.13.3	Keyword (Entry code) storage.....	406
19.13.4	Screens requiring keywords (entry codes) for access.....	406
19.13.5	Canceling an keyword (entry code).....	407
19.13.6	Enabling an entry code.....	408
19.14	Device All-Clear.....	408
19.14.1	Device all-clear operation.....	408
19.15	PLC Status.....	409
19.15.1	Display operation.....	409
19.15.2	PLC status display items.....	410
19.16	Scan Time (Scan Time Display).....	411
19.16.1	Scan time display operation.....	411
19.17	Cassette (Memory Cassette Transfers).....	411
19.17.1	Transfer from internal RAM to memory cassette (Cassette <- RAM).....	412
19.17.2	Transfer from memory cassette to internal RAM (Cassette -> RAM).....	413
19.17.3	Memory cassette & internal RAM consistency check (Cassette : RAM).....	414
19.18	System Information (Restrictions From PLC).....	415
19.18.1	System information list.....	415
19.18.2	System information setting program example.....	416
19.19	User (User-Registered Device Setting).....	417
19.19.1	System information - user-registered device setting.....	417
19.19.2	Precaution when setting 3 or fewer devices.....	417
19.19.3	Program example 1 (when 4 devices are displayed as user-registered devices).....	418
19.19.4	Program example 2 (when 3 or fewer devices are displayed as user-registered devices).....	419
19.19.5	Program example 3 (when 5 or more devices are displayed as user-registered devices).....	420
19.20	Operation Button ON/OFF Information.....	422
19.20.1	Various applications.....	422
19.20.2	System information - operation button ON/OFF information.....	422
19.21	Specifying a Hexadecimal Current Value Display Format.....	423
19.21.1	System information - specifying a hexadecimal current value display format.....	423
19.21.2	Program example 1 (specifying a hexadecimal data display format).....	423
19.21.3	Program example 2 (specifying a decadal data display format).....	423
19.22	Display Screen Protect Function.....	424
19.22.1	Keyword (Entry code) & display screen protect function levels and corresponding restrictions.....	424
19.22.2	Relationship between keyword (entry code) & display screen protect function.....	425
19.22.3	Keyword (Entry code) levels.....	425
19.22.4	System information - display screen protect function.....	426
19.22.5	Program example (screen protect function setting).....	426
19.22.6	Pointers for using the display screen protect function.....	426
19.23	User Message Display Function.....	427
19.23.1	System information - user message display function.....	427
19.23.2	Shift JIS code arrangement precautions.....	427
19.23.3	Displaying a word device current value as a message.....	428
19.23.4	Program example 1 (user messages display switching).....	428
19.23.5	Program example 2 ([+] / [-] buttons for user message switching).....	429
19.23.6	Program example 3 (user messages plus data display).....	430
19.23.7	Character data input procedure.....	433
19.24	Operation Error Messages & Corrective Actions.....	436
19.24.1	When a "Fatal error occurred" message appears.....	437
19.25	Menu Display Characters - Japanese & English Display Character Correspondence Table.....	438

20. FX-16/32E*-*-TB (Terminal Block)

439

20.1	Overview.....	441
20.1.1	Product configuration.....	442
20.2	External Dimensions & Component Names.....	443
20.3	Terminal Arrangement.....	444

20.4 Installation Work.....	446
20.4.1 Mounting.....	446
20.4.2 Removal.....	446
20.4.3 Input/output cable connection.....	446
20.4.4 Connection to terminal block.....	447
20.5 FX-16E-TB, FX-32E-TB.....	448
20.5.1 Internal circuit.....	448
20.5.2 Example of input external wiring.....	449
20.5.3 Output external wiring.....	449
20.6 FX-16EX-A1-TB.....	450
20.6.1 Specifications.....	450
20.6.2 Internal circuit.....	451
20.6.3 Example of input external wiring.....	451
20.7 FX-16EYR-TB.....	452
20.7.1 Specifications.....	452
20.7.2 Internal circuit.....	453
20.7.3 Example of output external wiring.....	453
20.7.4 External wiring precautions.....	454
20.7.5 Product life of relay output contacts.....	455
20.8 FX-16EYT-TB, FX-16EYT-H-TB.....	456
20.8.1 Specifications.....	456
20.8.2 Internal circuit.....	457
20.8.3 Example of output external wiring.....	457
20.8.4 External wiring precautions.....	458
20.9 FX-16EYS-TB.....	459
20.9.1 Specifications.....	459
20.9.2 Internal circuit.....	460
20.9.3 Example of output external wiring.....	460
20.9.4 External wiring precautions.....	461

21. FX3U-FLROM-16/64/64L/1M (Memory Cassette) 462

21.1 Specifications.....	462
21.1.1 Electrical specifications.....	462
21.1.2 Component names & external dimensions.....	462
21.2 Installation & Removal.....	463
21.2.1 Memory cassette installation.....	463
21.2.2 Memory cassette removal.....	464
21.3 Saved Data Content.....	465
21.4 PROTECT Switch.....	466
21.4.1 PROTECT switch setting.....	466
21.4.2 PROTECT switch operation.....	466
21.4.3 Precautions when setting and using the switch.....	466
21.5 Memory Cassette <-> PLC (RAM Memory) Transfers Using the Loader Function.....	467
21.5.1 Tool for pressing the [WR] and [RD] keys.....	467
21.5.2 Writing (WR: 64L -> PLC).....	467
21.5.3 Reading (RD: 64L <- PLC).....	468
21.6 Transfers By Display Module Operation.....	468
21.7 Operation Precautions.....	468

22. FX3U-32BL (Battery) 469

22.1 Battery Purpose.....	469
22.2 Specifications.....	469
22.2.1 Differences between main unit's internal battery and the optional battery.....	470
22.3 Battery Handling.....	470
22.3.1 Battery life & replacement guidelines.....	470
22.3.2 Reading the date of manufacture.....	470
22.3.3 Special "battery low-voltage" device & notification program example.....	471

22.4 Battery-Free Operation	471
22.5 Battery Replacement.....	472
22.6 Battery Related Precautions	472

Appendix A: Operation of Special Devices (M8000 -, D8000 -) 473

Appendix A-1 Special Auxiliary Relay (M8000 to M8511)	473
Appendix A-2 Special Data Register (D8000 to D8511).....	481
Appendix A-3 Analog special adapters [M8260 to M8299 and D8260 to D8299].....	489
Appendix A-3-1 Special auxiliary relays (M8260 to M8299).....	489
Appendix A-3-2 Special data registers (D8260 to D8299).....	491

Appendix B: Instruction List 493

Appendix B-1 Basic Instructions	493
Appendix B-2 Step Ladder Instructions	493
Appendix B-3 Applied Instructions ... in Ascending Order of FNC Number	494

Appendix C: Character-code 499

Appendix C-1 ASCII Code Table	499
-------------------------------------	-----

Appendix D: Discontinued models 501

Appendix E: Precautions for Battery Transportation 503

Appendix E-1 Regulated FX3U Series products	503
Appendix E-2 Transport guidelines.....	503

**Appendix F: Handling of Batteries and Devices with Built-in Batteries
in EU Member States 505**

Appendix F-1 Disposal precautions	505
Appendix F-2 Exportation precautions.....	505
Appendix F-3 Regulated FX3U Series products.....	505

Warranty..... 507

Revised History 508

Standards

Certification of UL, cUL standards

FX3U series main units, FX3U series special adapters and FX2N input/output extension units/blocks supporting UL, cUL standards are as follows:

UL, cUL file number : E95239

Models :

MELSEC FX3U series manufactured

FX3U-★ ★MR/ES FX3U-★ ★MT/ES FX3U-★ ★MT/ESS

Where ★ ★ indicates:16,32,48,64,80,128

FX3U-★ ★MR/DS FX3U-★ ★MT/DS FX3U-★ ★MT/DSS

Where ★ ★ indicates:16,32,48,64,80

FX3U-★ ★MS/ES FX3U-★ ★MR/UA1

Where ★ ★ indicates:32,64

FX3U-232ADP(-MB) FX3U-485ADP(-MB)

FX3U-4AD-ADP FX3U-4DA-ADP FX3U-3A-ADP FX3U-4AD-PT-ADP

FX3U-4AD-PTW-ADP FX3U-4AD-PNK-ADP FX3U-4AD-TC-ADP

FX3U-4HSX-ADP FX3U-2HSY-ADP

FX3U-CF-ADP

Models :

MELSEC FX2N series manufactured

FX2N-★ ★ER-ES/UL FX2N-★ ★ET-ESS/UL

Where ★ ★ indicates:32,48

FX2N-48ER-DS FX2N-48ET-DSS FX2N-48ER-UA1/UL

FX2N-8ER-ES/UL FX2N-8EX-ES/UL FX2N-8EYR-ES/UL FX2N-8EYR-S-ES/UL

FX2N-8EYT-ESS/UL FX2N-8EX-UA1/UL

FX2N-16EX-ES/UL FX2N-16EYR-ES/UL FX2N-16EYT-ESS/UL FX2N-16EYS

Compliance with EC directive (CE Marking)

This note does not guarantee that an entire mechanical module produced according to the contents of this note will comply with the following standards.

Compliance to EMC directive and LVD directive of the entire mechanical module should be checked by the user / manufacturer. For more details please contact to the local Mitsubishi Electric sales site.

Requirement for Compliance with EMC directive

The following products have shown compliance through direct testing (of the identified standards below) and design analysis (through the creation of a technical construction file) to the European Directive for Electromagnetic Compatibility (2004/108/EC) when used as directed by the appropriate documentation.

Attention

- This product is designed for use in industrial applications.

Note

- Manufactured by:
Mitsubishi Electric Corporation
2-7-3 Marunouchi, Chiyoda-ku, Tokyo, 100-8310 Japan
- Manufactured at:
Mitsubishi Electric Corporation Himeji Works
840 Chiyoda-machi, Himeji, Hyogo, 670-8677 Japan
- Authorized Representative in the European Community:
Mitsubishi Electric Europe B.V.
Gothaer Str. 8, 40880 Ratingen, Germany

Type :	Programmable Controller (Open Type Equipment)			
Models :	MELSEC FX3U series manufactured			
from May 1st, 2005	FX3U-★ ★MR/ES			
	Where ★ ★ indicates:16,32,48,64,80			
	FX3U-4HSX-ADP	FX3U-2HSY-ADP		
	FX3U-FLROM-16	FX3U-FLROM-64L		
	FX3U-7DM			
from June 1st, 2005	FX3U-232ADP	FX3U-485ADP		
	FX3U-4AD-ADP	FX3U-4DA-ADP	FX3U-4AD-PT-ADP	FX3U-4AD-TC-ADP
	FX3U-232-BD	FX3U-422-BD	FX3U-485-BD	FX3U-CNV-BD
	FX3U-USB-BD			
	FX3U-FLROM-64			
from November 1st, 2005	FX3U-★ ★MT/ES	FX3U-★ ★MT/ESS		
	Where ★ ★ indicates:16,32,48,64,80			
from February 1st, 2006	FX3U-128MR/ES	FX3U-128MT/ES	FX3U-128MT/ESS	
	FX3U-★ ★MR/DS	FX3U-★ ★MT/DS	FX3U-★ ★MT/DSS	
	Where ★ ★ indicates:16,32,48,64,80			
from April 1st, 2007	FX3U-232ADP-MB	FX3U-485ADP-MB		
from December 1st, 2007	FX3U-4AD-PTW-ADP	FX3U-4AD-PNK-ADP		
from June 1st, 2009	FX3U-3A-ADP	FX3U-CF-ADP		
from August 1st, 2010	FX3U-8AV-BD			
from September 1st, 2010	FX3U-★ ★MS/ES	FX3U-★ ★MR/UA1		
	Where ★ ★ indicates:32,64			
from May 1st, 2011	FX3U-FLROM-1M			

Standard	Remark
EN61131-2:2007 Programmable controllers - Equipment requirements and tests	Compliance with all relevant aspects of the standard. EMI <ul style="list-style-type: none"> • Radiated Emission • Conducted Emission EMS <ul style="list-style-type: none"> • Radiated electromagnetic field • Fast transient burst • Electrostatic discharge • High-energy surge • Voltage drops and interruptions • Conducted RF • Power frequency magnetic field

Models : MELSEC FX2N series manufactured

from July 1st, 1997	FX2N-★ ★ER-ES/UL	FX2N-★ ★ET-ESS/UL	
	Where ★ ★ indicates:32,48		
	FX2N-16EX-ES/UL	FX2N-16EYR-ES/UL	FX2N-16EYT-ESS/UL
from April 1st, 1998	FX2N-48ER-DS	FX2N-48ET-DSS	
from August 1st, 1998	FX2N-48ER-UA1/UL		
from August 1st, 2005	FX2N-8ER-ES/UL	FX2N-8EX-ES/UL	FX2N-8EYR-ES/UL
	FX2N-8EYT-ESS/UL		
from September 1st, 2010	FX2N-8EYR-S-ES/UL		

For the products above, PLCs manufactured before March 31st, 2002 are compliant with EN50081-2 (EN61000-6-4) and EN50082-2
from April 1st, 2002 to April 30th, 2006 are compliant with EN50081-2 (EN61000-6-4) and EN61131-2:1994 +A11:1996+A12:2000
after May 1st, 2006 are compliant with EN61131-2:2007

Standard		Remark
EN61000-6-4:2007	- Generic emission standard Industrial environment	Compliance with all relevant aspects of the standard.
EN50081-2:1993	Electromagnetic compatibility	<ul style="list-style-type: none"> • Emission-Enclosure port • Emission-Low voltage AC mains port • Emission-Telecommunications/network port
EN50082-2:1995	Electromagnetic compatibility - Generic immunity standard Industrial environment	Compliance with all relevant aspects of the standard.
		<ul style="list-style-type: none"> • RF immunity • Fast Transients • ESD • Conducted • Power magnetic fields
EN61131-2:1994 /A11:1996 /A12:2000	Programmable controllers - Equipment requirements and tests	Compliance with all relevant aspects of the standard.
		<ul style="list-style-type: none"> • Radiated electromagnetic field • Fast transient burst • Electrostatic discharge • Damped oscillatory wave
EN61131-2:2007	Programmable controllers - Equipment requirements and tests	Compliance with all relevant aspects of the standard.
		EMI <ul style="list-style-type: none"> • Radiated Emission • Conducted Emission EMS <ul style="list-style-type: none"> • Radiated electromagnetic field • Fast transient burst • Electrostatic discharge • High-energy surge • Voltage drops and interruptions • Conducted RF • Power frequency magnetic field

Requirement for Compliance with LVD directive

The following products have shown compliance through direct testing (of the identified standards below) and design analysis (through the creation of a technical construction file) to the European Directive for Low Voltage (2006/95/EC) when used as directed by the appropriate documentation.

Type : Programmable Controller (Open Type Equipment)

Models : MELSEC FX3U series manufactured

from May 1st, 2005	FX3U-★ ★MR/ES		
	Where ★ ★ indicates:16,32,48,64,80		
from November 1st, 2005	FX3U-★ ★MT/ES	FX3U-★ ★MT/ESS	
	Where ★ ★ indicates:16,32,48,64,80		
from February 1st, 2006	FX3U-128MR/ES	FX3U-128MT/ES	FX3U-128MT/ESS
	FX3U-★ ★MR/DS		
	Where ★ ★ indicates:16,32,48,64,80		
from September 1st, 2010	FX3U-★ ★MS/ES	FX3U-★ ★MR/UA1	
	Where ★ ★ indicates:32,64		

Standard	Remark
EN61131-2:2007 Programmable controllers - Equipment requirements and tests	The equipment has been assessed as a component for fitting in a suitable enclosure which meets the requirements of EN61131-2:2007

Models : MELSEC FX2N series manufactured

from July 1st, 1997	FX2N-★ ★ER-ES/UL	FX2N-★ ★ET-ESS/UL
	Where ★ ★ indicates:32,48	
	FX2N-16EYR-ES/UL	
from April 1st, 1998	FX2N-48ER-DS	
from August 1st, 1998	FX2N-48ER-UA1/UL	
from August 1st, 2005	FX2N-8ER-ES/UL	FX2N-8EYR-ES/UL
from September 1st, 2010	FX2N-8EYR-S-ES/UL	

For the products above, PLCs manufactured
before March 31st, 2002 are compliant with IEC1010-1
from April 1st, 2002 to April 30th, 2006 are compliant with EN61131-2:1994+A11:1996+A12:2000
after May 1st, 2006 are compliant with EN61131-2:2007

Standard	Remark
IEC1010-1:1990 Safety requirements for electrical /A1:1992 equipment for measurement, control, and laboratory use - General requirements	The equipment has been assessed as a component for fitting in a suitable enclosure which meets the requirements of IEC 1010-1:1990+A1:1992
EN61131-2:1994 Programmable controllers /A11:1996 - Equipment requirements and tests /A12:2000	The equipment has been assessed as a component for fitting in a suitable enclosure which meets the requirements of EN61131-2:1994+A11:1996+A12:2000
EN61131-2:2007 Programmable controllers - Equipment requirements and tests	The equipment has been assessed as a component for fitting in a suitable enclosure which meets the requirements of EN61131-2:2007

Caution for compliance with EC Directive

1. Installation in Enclosure

Programmable logic controllers are open-type devices that must be installed and used within conductive control boxes. Please use the FX3U Series programmable logic controllers while installed in conductive shielded control boxes. Please secure the control box lid to the control box (for conduction). Installation within a control box greatly affects the safety of the system and aids in shielding noise from the programmable logic controller.

2. Caution for Analog Products in use

The analog special adapters have been found to be compliant to the European standards in the aforesaid manual and directive. However, for the very best performance from what are in fact delicate measuring and controlled output devices, Mitsubishi Electric would like to make the following points;

As analog devices are sensitive by nature, their use should be considered carefully. For users of proprietary cables (integral with sensors or actuators), these users should follow those manufacturers' installation requirements.

Mitsubishi Electric recommends that shielded cables be used. If NO other EMC protection is provided, users may experience temporary induced errors not exceeding +10%/-10% in very heavy industrial areas.

However, Mitsubishi Electric suggests that if adequate EMC precautions are followed for the users complete control system.

- Sensitive analog cables should not be laid in the same trunking or cable conduit as high voltage cabling. Where possible, users should run analog cables separately.
- Good cable shielding should be used. When terminating the shield at Earth - ensure that no earth loops are accidentally created.
- When reading analog values, EMC induced errors can be smoothed out by averaging the readings. This can be achieved either through functions on the analog special adapters/blocks or through a user's program in the FX3U Series PLC main unit.

1. Introduction

This manual explains the procedures for selecting the system components, main unit specifications and procedures for installing the main unit, specifications for the input/output powered extension units/blocks, and procedures for adding input/output devices, and procedures for operating the display module etc. FX3U PLCs can make various kinds of control in combination with the main unit functions and many extension devices (expansion board, special adapters and special function units/blocks). The detailed explanation of the sequence instructions, communication control, analog control and positioning control are given in separate manuals.

→ For information on manual organization, refer to Subsection 1.1.2.

1.1 Introduction of Manuals

1.1.1 Classification of major components in this manual

1. Main unit (Chapter 1 to 14)

Division	Outline	Reference
Introduction of manuals	This chapter contains explanations of the procedures for obtaining the manuals and the abbreviations.	Chapter 1
Features and part names	This chapter contains explanations of the product features and the names and functions of the parts.	Chapter 2
Introduction of product	This chapter contains explanations of the structures for model names, extension products, and compliance to overseas standards.	Chapter 3
Specifications	This chapter contains explanations of the specifications for power supply and input/output, external dimensions and terminal block layout.	Chapter 4
Version information	This chapter contains explanation for upgrading of FX3U PLCs and information for the application of programming tools.	Chapter 5
System configuration	Procedure for determining whether or not a system configuration is possible. Extension device current consumption and configuration examples.	Chapter 6
Input/output No. and unit No. assignment	Input/output assignment procedure for input/output powered extension units/blocks, etc., and unit No. assignment procedure for special function unit/blocks.	Chapter 7
Installation	This chapter contains explanations for the panel layout and the procedures for installing with DIN rail or screws and how to connect extension devices.	Chapter 8
Power supply wiring	This chapter contains explanations of the procedures for preparing for wiring, power supply specifications and instructions for wiring.	Chapter 9
Input wiring	This chapter contains explanations of the input specifications and instructions for wiring.	Chapter 10
High-speed counter	This chapter contains explanations of the procedures for using the high-speed counter (FX3U-4HSX-ADP) examples of programming.	Chapter 11
Output wiring	This chapter contains explanations for the output specifications and instructions for wiring.	Chapter 12
Examples of wiring for each use	This chapter contains explanations of the procedures for wiring input/output devices for main uses.	Chapter 13
Test operation, adjustment, maintenance and error check	This chapter contains explanations of the procedures for test operation and adjustment, maintenance and error check items and measures to be taken upon occurrence of error.	Chapter 14

2. Extension devices (Chapter 15 to 18)

Division	Outline	Reference
Input/output powered extension units	This chapter contains explanations for the input/output specifications, external dimensions and terminal layout for each product.	Chapter 15
Input/output extension blocks		Chapter 16
Extension power supply unit	This chapter contains explanations of specifications for the extension power supply unit and external dimensions.	Chapter 17
Extension products for special functions, such as analog control, positioning and communication	This chapter contains explanations for the external dimensions and terminal layout (For details, refer to the manual for each extension device).	Chapter 18

3. Optional products (Chapter 19 to 22)

Division	Outline	Reference
Display module	This chapter contains explanation of the specifications, external dimensions, mounting procedures and operating procedures for display modules.	Chapter 19
FX Series terminal blocks	This chapter contains explanations of the procedures for wiring FX-16/32E□-TB.	Chapter 20
Memory cassette	This chapter contains explanations of the specifications for the memory cassette and the installation procedures.	Chapter 21
Battery	This chapter contains explanations of the procedures for replacing the battery and detecting battery voltage drop.	Chapter 22

4. Others (Appendices A to F)

Division	Outline	Reference
List of special devices	This chapter contains an explanation list of the special auxiliary relays (M8000 to M8511) and special data registers (D8000 to D8511) (For details, refer to the programming manual.)	Appendix A
List of instructions	This chapter contains an explanation list of the basic instructions and applied instructions (For details, refer to the programming manual.)	Appendix B
List of character codes	This chapter contains an explanation list of the character codes that can be displayed on the display module (FX3U-7DM)	Appendix C
List of discontinued models	The discontinued MELSEC-F Series PLC models and programming tools described in this manual.	Appendix D
Precautions for battery transportation	This chapter contains explanations for transport regulations and guidelines.	Appendix E
Handling of batteries and devices with Built-in batteries in EU member states	This chapter contains explanations for the disposal precautions of batteries and exporting batteries to EU member states.	Appendix F

1.1.2 Manual organization and position of this manual

This manual describes detail on the hardware, including the system configuration, selection, installation and wiring. The instructions, communication control, analog control and positioning control are explained in separate manuals. Refer to the manuals as needed.

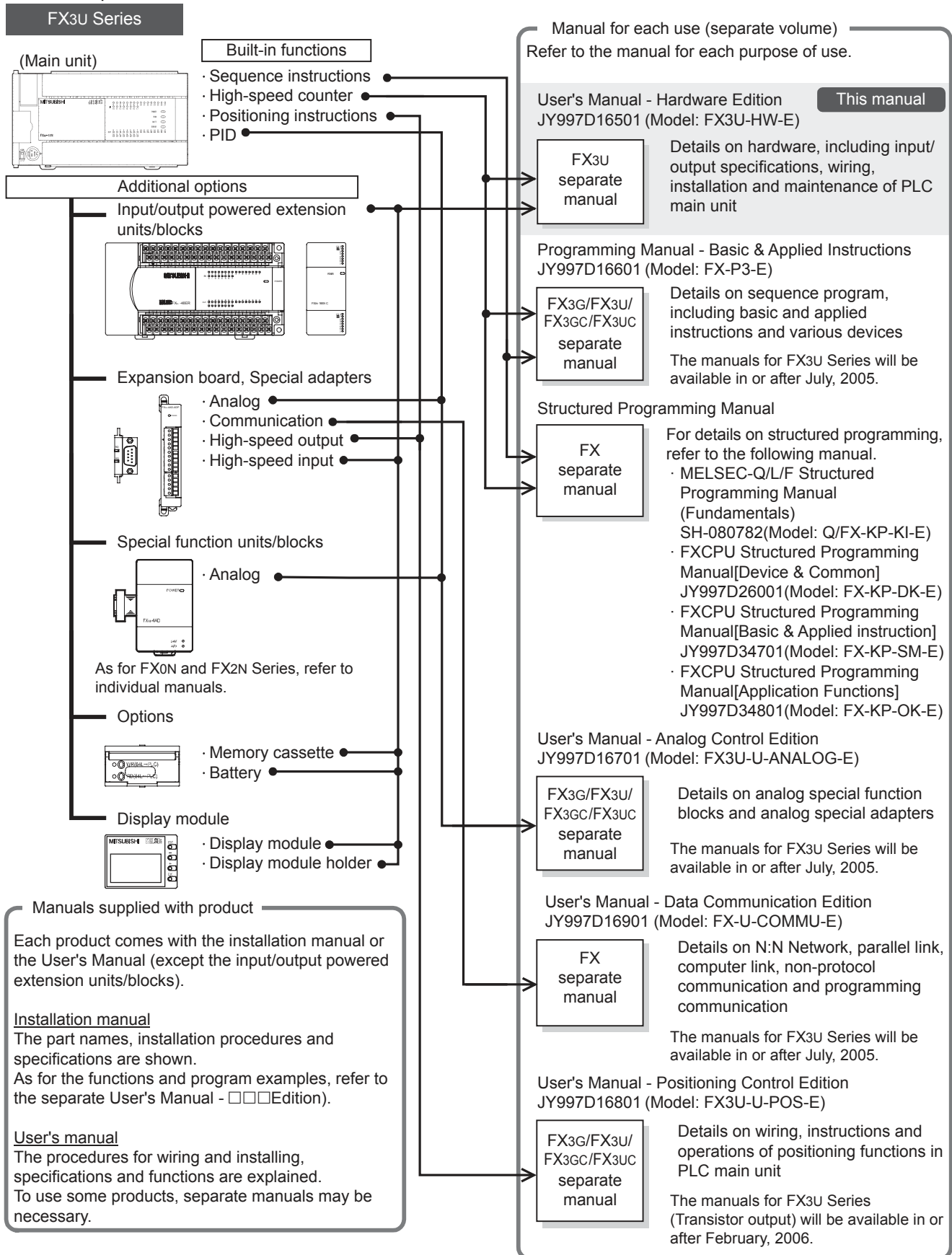

1	Introduction
2	Features and Part Names
3	Product Introduction
4	Specifications
5	Version and Peripheral Devices
6	System Configuration
7	Input/Output Nos., Unit Nos.
8	Installation
9	Preparation and Power Supply Wiring
10	Input Wiring

1.1.3 List of manuals

FX3U Series PLC main units supplied only with the hardware manual.

For details on the hardware of FX3U Series, refer to this manual.

For instructions for programming and hardware information on special function devices, refer to the relevant manuals.

⊙: Indispensable manuals

✓: Manuals necessary for some purposes

△: Manuals with separate volumes for details

		Manual title	Manual number	Contents	Model name code
Manuals for PLC main unit					
■FX3U PLC main unit					
△	Supplied with product	FX3U Series HARDWARE MANUAL	JY997D18801	Extractions of descriptions of input/output specifications, wiring and installation of FX3U Series PLC main unit from FX3U Series User's Manual - Hardware Edition For the detailed explanation, refer to this manual.	-
⊙	Separate volume	FX3U Series User's Manual - Hardware Edition (this manual)	JY997D16501	Details on hardware of FX3U Series PLC main unit, including input/output specifications, wiring, installation and maintenance	09R516
■Programming					
⊙	Separate volume	FX3G/FX3U/FX3GC/FX3UC Series Programming Manual - Basic & Applied Instruction Edition	JY997D16601	Details on sequence programming for FX3U Series, including explanation for basic instructions, applied instructions and various devices	09R517
✓	Separate volume	MELSEC-Q/L/F Structured Programming Manual (Fundamentals)	SH-080782	Programming methods, specifications, functions, etc. required to create structured programs	13JW06
✓	Separate volume	FX CPU Structured Programming Manual [Device & Common]	JY997D26001	Devices, parameters, etc. provided in structured projects of GX Works2	09R925
✓	Separate volume	FX CPU Structured Programming Manual [Basic & Applied Instruction]	JY997D34701	Sequence instructions provided in structured projects of GX Works2	09R926
✓	Separate volume	FX CPU Structured Programming Manual [Application Functions]	JY997D34801	Application functions provided in structured projects of GX Works2	09R927
■FX Series terminal block					
✓	Supplied with product	FX INPUT AND OUTPUT TERMINAL BLOCKS USER'S GUIDE	JY992D50401	Handling procedures for FX Series terminal block	-
Manuals for communication control					
■Common					
✓	Separate volume	FX Series User's Manual - Data Communication Edition	JY997D16901	Details on N:N Network, parallel link, computer link and non-protocol communication (RS instructions, FX2N-232IF)	09R715
✓	Separate volume	FX3G/FX3U/FX3GC/FX3UC Series User's Manual - MODBUS Serial Communication Edition	JY997D26201	Details on MODBUS serial communication in FX3G/FX3U/FX3GC/FX3UC PLCs.	-

- ⊙: Indispensable manuals
- ✓: Manuals necessary for some purposes
- △: Manuals with separate volumes for details

	Manual title	Manual number	Contents	Model name code	
■RS-232C/RS-422/RS-485/USB communication					
When using each product, also refer to the User's Manual - Hardware Edition for the PLC main unit to be installed.					
△	Supplied with product	FX3U-USB-BD User's Manual	JY997D13501	System configuration of the USB communication expansion board and procedures for installing the driver When using, also refer to FX Series User's Manual - Data Communication Edition.	-
△	Supplied with product	FX3U-232-BD Installation Manual	JY997D12901	Handling procedures for the RS-232C communication expansion board When using, also refer to FX Series User's Manual - Data Communication Edition.	-
△	Supplied with product	FX3U-232ADP-MB Installation Manual	JY997D26401	Details on handling the RS-232C communication special adapter. For details on MODBUS serial communication, refer to the FX3G/FX3U/FX3GC/FX3UC Series User's Manual - MODBUS Serial Communication Edition. For details on other supported serial communication, refer to the FX Series User's Manual - Data Communication Edition.	-
△	Supplied with product	FX3U-232ADP Installation Manual	JY997D13701	Handling procedures for the RS-232C communication special adapter When using, also refer to FX Series User's Manual - Data Communication Edition.	-
△	Supplied with product	FX2N-232IF Hardware Manual	JY992D73501	Handling procedures for the RS-232C communication special function block When using, also refer to FX Series User's Manual - Data Communication Edition.	-
△	Supplied with product	FX3U-422-BD Installation Manual	JY997D13101	Handling procedures for the RS-422 communication expansion board When using, also refer to FX Series User's Manual - Data Communication Edition.	-
△	Supplied with product	FX3U-485-BD Installation Manual	JY997D13001	Handling procedures for the RS-485 communication expansion board When using, also refer to FX Series User's Manual - Data Communication Edition.	-
△	Supplied with product	FX3U-485ADP-MB Installation Manual	JY997D26301	Details on handling the RS-485 communication special adapter. For details on MODBUS serial communication, refer to the FX3G/FX3U/FX3GC/FX3UC Series User's Manual - MODBUS Serial Communication Edition. For details on other supported serial communication, refer to the FX Series User's Manual - Data Communication Edition.	-
△	Supplied with product	FX3U-485ADP Installation Manual	JY997D13801	Handling procedures for the RS-485 communication special adapter When using, also refer to FX Series User's Manual - Data Communication Edition.	-
✓	Supplied with product	FX-485PC-IF Hardware Manual	JY992D81801	Handling procedures for the RS-232C/RS-485 conversion interface When using, also refer to FX Series User's Manual - Data Communication Edition.	-

1	Introduction
2	Features and Part Names
3	Product Introduction
4	Specifications
5	Version and Peripheral Devices
6	System Configuration
7	Input/Output Nos., Unit Nos.
8	Installation
9	Preparation and Power Supply Wiring
10	Input Wiring

- ⊙: Indispensable manuals
- ✓: Manuals necessary for some purposes
- △: Manuals with separate volumes for details

	Manual title	Manual number	Contents	Model name code	
■CC-Link, CC-Link/LT, MELSEC I/O LINK, and AS-i system					
When using each product, also refer to the User's Manual - Hardware Edition for the PLC main unit to be installed.					
△	Supplied with product	FX3U-16CCL-M Installation Manual	JY997D43401	Handling procedures for the CC-Link master special function block When using, also refer to FX3U-16CCL-M User's Manual.	-
✓	Separate volume	FX3U-16CCL-M User's Manual	JY997D43601	Details on CC-Link master special function block	09R724
△	Supplied with product	FX2N-16CCL-M Hardware Manual	JY992D93201	Handling procedures for the CC-Link master special function block When using, also refer to FX2N-16CCL-M User's Manual.	-
✓	Separate volume	FX2N-16CCL-M User's Manual	JY992D93101	Details on CC-Link master special function block	09R710
△	Supplied with product	FX3U-64CCL Installation Manual	JY997D29801	Details on handling the CC-Link interface special function block. When using, also refer to the FX3U-64CCL User's Manual.	-
✓	Separate volume	FX3U-64CCL User's Manual	JY997D30401	Details on the CC-Link interface special function block	09R718
✓	Supplied with product	FX2N-32CCL User's Manual	JY992D71801	Handling procedures for the CC-Link remote device station special function block	09R711
✓	Supplied with product	Remote I/O station, remote device station and intelligent device station for CC-Link	As for the remote I/O station, remote device station and intelligent device station for CC-Link, refer to the relevant manuals and related documents.		-
△	Supplied with product	FX2N-64CL-M User's Manual - Hardware Volume	JY997D05401	Handling procedures for the CC-Link/LT master special function block When using, also refer to FX2N-64CL-M User's Manual - Details.	-
✓	Separate volume	FX2N-64CL-M User's Manual - Detailed Volume	JY997D08501	Details on the CC-Link/LT master special function block	-
✓	Supplied with product	Remote I/O station, remote device station, power supply adapter and dedicated power supply for CC-Link/LT	As for the remote I/O station, remote device station power supply adapter and dedicated power supply for CC-Link/LT, refer to the relevant manuals and related documents.		-
✓	Supplied with product	FX2N-32ASI-M User's Manual	JY992D76901	Handling procedures for the AS-i system master special function block	-
✓	Supplied with product	FX2N-16LNK-M User's Manual	JY992D72101	Handling procedures for the MELSEC I/O LINK master special function block	09R703
Manuals for analog/temperature control					
■Common					
✓	Separate volume	FX3G/FX3U/FX3GC/ FX3UC Series User's Manual - Analog Control Edition	JY997D16701	Details on analog special function block (FX3U-4AD, FX3U-4DA, FX3UC-4AD) and analog special adapter (FX3U-***-**-ADP)	09R619
■Analog input, temperature input and temperature control					
When using each product, also refer to the User's Manual - Hardware Edition for the PLC main unit to be installed.					
✓	Supplied with product	FX2N-2AD User's Guide	JY992D74701	Handling procedures for the 2-ch analog input special function block	-

- ⊙: Indispensable manuals
- ✓: Manuals necessary for some purposes
- △: Manuals with separate volumes for details

		Manual title	Manual number	Contents	Model name code
△	Supplied with product	FX3U-4AD Installation Manual	JY997D20701	Handling procedures for the 4-ch analog input special function block When using, also refer to FX3G/FX3U/FX3GC/FX3UC Series User's Manual - Analog Control Edition.	-
△	Supplied with product	FX3U-4AD-ADP User's Manual	JY997D13901	Handling procedures for the 4-ch analog input special adapter When using, also refer to FX3G/FX3U/FX3GC/FX3UC Series User's Manual - Analog Control Edition.	-
✓	Supplied with product	FX2N-4AD User's Guide	JY992D65201	Handling procedures for the 4-ch analog input special function block	-
✓	Supplied with product	FX2N-8AD User's Manual	JY992D86001	Handling procedures for the 8-ch analog input special function block (to be used also for thermocouple input)	09R608
△	Supplied with product	FX3U-4AD-PT-ADP User's Manual	JY997D14701	Handling procedures for the 4-ch Pt100 temperature sensor input special adapter When using, also refer to FX3G/FX3U/FX3GC/FX3UC Series User's Manual - Analog Control Edition.	-
△	Supplied with product	FX3U-4AD-PTW-ADP User's Manual	JY997D29101	Details on handling the 4-ch Pt100 temperature sensor input special adapter When using, also refer to FX3G/FX3U/FX3GC/FX3UC Series User's Manual - Analog Control Edition.	-
△	Supplied with product	FX3U-4AD-PNK-ADP User's Manual	JY997D29201	Details on handling the 4-ch Pt1000/Ni1000 temperature sensor input special adapter When using, also refer to FX3G/FX3U/FX3GC/FX3UC Series User's Manual - Analog Control Edition.	-
✓	Supplied with product	FX2N-4AD-PT User's Guide	JY992D65601	Handling procedures for the 4-ch Pt100 temperature sensor input special function block	-
△	Supplied with product	FX3U-4AD-TC-ADP User's Manual	JY997D14801	Handling procedures for the 4-ch thermocouple input special adapter When using, also refer to FX3G/FX3U/FX3GC/FX3UC Series User's Manual - Analog Control Edition.	-
✓	Supplied with product	FX2N-4AD-TC User's Guide	JY992D65501	Handling procedures for the 4-ch thermocouple input special function block	-
△	Supplied with product	FX2N-2LC User's Guide	JY992D85601	Handling procedures for the 2-ch temperature control special function block When using, refer to FX2N-2LC User's Manual.	-
✓	Separate volume	FX2N-2LC User's Manual	JY992D85801	Handling procedures for the 2-ch temperature control special function block	09R607
△	Supplied with product	FX3U-4LC Installation Manual	JY997D38901	Handling procedures for the 4-ch temperature control special function block When using, refer to FX3U-4LC User's Manual.	-
✓	Separate volume	FX3U-4LC User's Manual	JY997D39101	Handling procedures for the 4-ch temperature control special function block	09R625

1	Introduction
2	Features and Part Names
3	Product Introduction
4	Specifications
5	Version and Peripheral Devices
6	System Configuration
7	Input/Output Nos., Unit Nos.
8	Installation
9	Preparation and Power Supply Wiring
10	Input Wiring

- ⊙: Indispensable manuals
- ✓: Manuals necessary for some purposes
- △: Manuals with separate volumes for details

	Manual title	Manual number	Contents	Model name code	
■Analog output					
When using each product, also refer to the User's Manual - Hardware Edition for the PLC main unit to be installed.					
✓	Supplied with product	FX2N-2DA User's Guide	JY992D74901	Handling procedures for the 2-ch analog output special function block	-
△	Supplied with product	FX3U-4DA Installation Manual	JY997D20801	Handling procedures for the 4-ch analog output special function block When using, also refer to FX3G/FX3U/FX3GC/FX3UC Series User's Manual - Analog Control Edition.	-
△	Supplied with product	FX3U-4DA-ADP User's Manual	JY997D14001	Handling procedures for the 4-ch analog output special adapter When using, also refer to FX3G/FX3U/FX3GC/FX3UC Series User's Manual - Analog Control Edition.	-
✓	Supplied with product	FX2N-4DA User's Guide	JY992D65901	Handling procedures for the 4-ch analog output special function block	-
■Analog input/output (mixed)					
When using each product, also refer to the User's Manual - Hardware Edition for the PLC main unit to be installed.					
△	Supplied with product	FX3U-3A-ADP User's Manual	JY997D35601	Handling procedures for the 2-ch analog input and 1-ch analog output special adapter When using, also refer to FX3G/FX3U/FX3GC/FX3UC Series User's Manual - Analog Control Edition.	-
✓	Supplied with product	FX0N-3A User's Guide	JY992D49001	Handling procedures for the 2-ch analog input and 1-ch analog output special function block	-
✓	Supplied with product	FX2N-5A User's Manual	JY997D11401	Handling procedures for the 4-ch analog input and 1-ch analog output special function block	09R616
Manuals for high-speed counter					
■High-speed counter					
When using each product, also refer to the User's Manual - Hardware Edition for the PLC main unit to be installed.					
△	Supplied with product	FX3U-4HSX-ADP Installation Manual	JY997D16301	Handling procedures for the high-speed input special adapter	-
✓	Supplied with product	FX2N-1HC User's Guide	JY992D65401	Handling procedures for the 1-ch high-speed counter special function block	-
✓	Supplied with product	FX3U-2HC User's Manual	JY997D36701	Handling procedures for the 2-ch high-speed counter special function block	-
Manuals for positioning control					
■Common					
✓	Separate volume	FX3G/FX3U/FX3GC/FX3UC Series User's Manual - Positioning Control Edition	JY997D16801	Details on positioning functions of FX3G/FX3U/FX3GC/FX3UC Series	09R620

- ⊙: Indispensable manuals
- ✓: Manuals necessary for some purposes
- △: Manuals with separate volumes for details

	Manual title	Manual number	Contents	Model name code	
■ Pulse output and positioning					
When using each product, also refer to the User's Manual - Hardware Edition for the PLC main unit to be installed.					
△	Supplied with product	FX3U-2HSY-ADP Installation Manual	JY997D16401	Handling procedures for the high-speed output special adapter When using, also refer to FX3G/FX3U/FX3GC/FX3UC Series User's Manual - Positioning Control Edition.	-
✓	Supplied with product	FX2N/FX-1PG User's Manual	JY992D65301	Handling procedures for the 1-axis pulse output special function block	09R610
△	Supplied with product	FX2N-10PG Installation Manual	JY992D91901	Handling procedures for the 1-axis pulse output special function block When using, refer to FX2N-10PG User's Manual.	-
✓	Separate volume	FX2N-10PG User's Manual	JY992D93401	Details on 1-axis pulse output special function block	09R611
△	Supplied with product	FX2N-10GM User's Guide	JY992D77701	Handling procedures for the 1-axis positioning special function unit When using, refer to FX2N-10GM/FX2N-20GM Handy Manual.	-
△	Supplied with product	FX2N-20GM User's Guide	JY992D77601	Handling procedures for the 2-axis positioning special function unit When using, refer to FX2N-10GM/FX2N-20GM Handy Manual.	-
✓	Separate volume	FX2N-10GM/FX2N-20GM Hardware/Programming Manual	JY992D77801	Handling procedures for the 1-axis/2-axis positioning special function unit	09R612
■ Programmable cam switch					
When using each product, also refer to the User's Manual - Hardware Edition for the PLC main unit to be installed.					
✓	Supplied with product	FX2N-1RM-E-SET User's Manual	JY992D71101	Handling procedures for the programmable cam switch special function unit	09R614
Manuals for FX3U-20SSC-H Positioning Block					
△	Supplied with product	FX3U-20SSC-H Installation Manual	JY997D21101	Handling procedures for the 2-axis positioning special function block When using, refer to FX3U-20SSC-H User's Manual.	-
✓	Separate volume	FX3U-20SSC-H User's Manual	JY997D21301	Describes FX3U-20SSC-H Positioning block details.	09R622
✓	Supplied with product	FX Configurator-FP Operation Manual	JY997D21801	Describes operation details on FX Configurator-FP Configuration Software.	09R916
Manuals for FX3U-CF-ADP					
△	Supplied with product	FX3U-CF-ADP Installation Manual	JY997D35201	Describes FX3U-CF-ADP specification extracted from the FX3U-CF-ADP User's Manual. When using, refer to FX3U-CF-ADP User's Manual.	-
✓	Separate volume	FX3U-CF-ADP User's Manual	JY997D35401	Describes FX3U-CF-ADP CF card special adapter details.	09R720

1	Introduction
2	Features and Part Names
3	Product Introduction
4	Specifications
5	Version and Peripheral Devices
6	System Configuration
7	Input/Output Nos., Unit Nos.
8	Installation
9	Preparation and Power Supply Wiring
10	Input Wiring

- ⊙: Indispensable manuals
- ✓: Manuals necessary for some purposes
- △: Manuals with separate volumes for details

		Manual title	Manual number	Contents	Model name code
Manuals for FX-30P					
△	Supplied with product	FX-30P Installation Manual	JY997D34201	Describes FX-30P specification extracted from the FX-30P Operation manual. When using, refer to FX-30P Operation manual.	-
✓	Separate volume	FX-30P Operation Manual	JY997D34401	Describes Handy Programming Panel FX-30P details.	09R924
Other manuals					
When using each product, also refer to the User's Manual - Hardware Edition for the PLC main unit to be installed.					
■Variable analog potentiometers					
△	Supplied with product	FX3U-8AV-BD User's Manual	JY997D40901	Handling procedures for the 8-ch variable analog potentiometers expansion board When using, refer to FX3G/FX3U/FX3GC/FX3UC Series Programming Manual - Basic & Applied Instruction Edition	-
■Connector conversion					
△	Supplied with product	FX3U-CNV-BD Installation Manual	JY997D13601	Handling procedures for the conversion function expansion board for connectors for connecting communication, CF card and analog special adapters	-
■Battery (maintenance option)					
△	Supplied with product	FX3U-32BL Battery	JY997D14101	Battery life and handling procedures	-
■Display module					
△	Supplied with product	FX3U-7DM User's Manual	JY997D17101	Procedures for mounting and handling the display module	-
■Display module holder					
△	Supplied with product	FX3U-7DM-HLD User's Manual	JY997D15401	Procedures for mounting and handling the display module holder	-
■Memory cassette					
△	Supplied with product	FX3U-FLROM-16/64/64L/1M Hardware Manual	JY997D12801	Specifications and operating procedures of the memory cassette	-
■Extension power supply unit					
△	Supplied with product	FX3U-1PSU-5V Installation Manual	JY997D22501	Specifications and operating procedures of the extension power supply unit	-

1.2 Generic Names and Abbreviations Used in Manuals

Abbreviation/ generic name	Description
PLCs	
FX3U Series	Generic name for FX3U Series PLCs
FX2N Series	Generic name for FX2N Series PLCs
FX0N Series	Generic name for FX0N Series PLCs
FX3U PLCs or main units	Abbreviation of FX3U Series PLC main units
FX3UC PLCs or main units	Abbreviation of FX3UC Series PLC main units
Expansion boards	Generic name for the following models FX3U-USB-BD, FX3U-232-BD, FX3U-422-BD, FX3U-485-BD, FX3U-8AV-BD, FX3U-CNV-BD
Special adapters	Generic name for high-speed input-output special adapters, communication special adapters, CF card special adapter and analog special adapters
High-speed input/output special adapters	Generic name for the following models FX3U-4HSX-ADP, FX3U-2HSY-ADP
Communication special adapters	Generic name for the following models FX3U-232ADP(-MB), FX3U-485ADP(-MB)
CF card special adapter CF-ADP	Generic name for the following model FX3U-CF-ADP
Analog special adapters	Generic name for the following models FX3U-4AD-ADP, FX3U-4DA-ADP, FX3U-3A-ADP, FX3U-4AD-PT-ADP, FX3U-4AD-PTW-ADP, FX3U-4AD-PNK-ADP, FX3U-4AD-TC-ADP
Extension devices	Generic name for FX3U Series extension devices, FX2N Series extension devices, FX2NC Series extension devices and FX0N Series extension devices The devices that can be added depending on the main unit to be used. For applicable devices, refer to the User's Manual - Hardware Edition for the main unit to be used.
FX3U Series extension devices	Generic name for FX3U Series special function blocks
FX2N Series extension devices	Generic name for FX2N Series input/output powered extension units, FX2N Series input/output extension blocks, FX2N Series special function units and FX2N Series special function blocks
FX0N Series extension devices	Generic name for FX0N Series special function block
Input/output extension devices	Generic name for FX2N Series input/output powered extension units, FX2N Series input/output extension blocks The devices that can be added depending on the main unit to be used. For applicable devices, refer to the User's Manual - Hardware Edition for the main unit to be used.
FX2N Series input/output powered extension units	Generic name for the following models FX2N-32ER-ES/UL, FX2N-32ER, FX2N-32ES, FX2N-32ET-ESS/UL, FX2N-32ET, FX2N-48ER, FX2N-48ER-ES/UL, FX2N-48ET, FX2N-48ET-ESS/UL, FX2N-48ER-UA1/UL, FX2N-48ER-DS, FX2N-48ET-DSS, FX2N-48ER-D, FX2N-48ET-D
FX2N Series input/output extension blocks	Generic name for the following models FX2N-8ER-ES/UL, FX2N-8ER
FX2N Series input extension blocks	Generic name for the following models FX2N-16EX-ES/UL, FX2N-16EX, FX2N-16EX-C, FX2N-16EXL-C, FX2N-8EX-ES/UL, FX2N-8EX-UA1/UL, FX2N-8EX
FX2N Series output extension blocks	Generic name for the following models FX2N-16EYR-ES/UL, FX2N-16EYR, FX2N-16EYT-ESS/UL, FX2N-16EYT, FX2N-16EYS, FX2N-16EYT-C, FX2N-8EYR-ES/UL, FX2N-8EYR-S-ES/UL, FX2N-8EYT-ESS/UL, FX2N-8EYR, FX2N-8EYT, FX2N-8EYT-H
Special function units/blocks	Generic name for FX2N Series special function units, FX3U Series special function blocks, FX2N Series special function blocks and FX0N Series special function blocks The devices that can be added depending on the main unit to be used. For applicable devices, refer to the User's Manual - Hardware Edition for the main unit to be used.
FX3U Series special function blocks	Generic name for the following models FX3U-16CCL-M, FX3U-64CCL, FX3U-4AD, FX3U-4LC, FX3U-4DA, FX3U-2HC, FX3U-20SSC-H

1	Introduction
2	Features and Part Names
3	Product Introduction
4	Specifications
5	Version and Peripheral Devices
6	System Configuration
7	Input/Output Nos., Unit Nos.
8	Installation
9	Preparation and Power Supply Wiring
10	Input Wiring

Abbreviation/ generic name	Description
FX2N Series special function units	Generic name for the following models FX2N-10GM, FX2N-20GM, FX2N-1RM(-E)-SET
FX2N Series special function blocks	Generic name for the following models FX2N-232IF, FX2N-16CCL-M, FX2N-32CCL, FX2N-64CL-M, FX2N-16LNK-M, FX2N-32ASI-M, FX2N-2AD, FX2N-4AD, FX2N-8AD, FX2N-4AD-PT, FX2N-4AD-TC, FX2N-2LC, FX2N-2DA, FX2N-4DA, FX2N-5A, FX2N-1HC, FX2N-1PG(-E), FX2N-10PG The devices that can be added depending on the main unit to be used. For applicable devices, refer to the User's Manual - Hardware Edition for the main unit to be used.
FX0N Series special function blocks	Generic name for the following models FX0N-3A
Display module	Generic name for the following models FX3U-7DM
Memory cassettes	Generic name for the following models FX3U-FLROM-16, FX3U-FLROM-64, FX3U-FLROM-64L, FX3U-FLROM-1M
Battery	Abbreviation of model FX3U-32BL battery
FX Series terminal blocks	Generic name for the following models FX-16E-TB, FX-32E-TB, FX-16EX-A1-TB, FX-16EYR-TB, FX-16EYS-TB, FX-16EYT-TB, FX-16EYT-H-TB The devices that can be added depending on the main unit to be used. For applicable devices, refer to the User's Manual - Hardware Edition for the main unit to be used.
Extension cables	Generic name for the following models FX0N-30EC, FX0N-65EC
Input/output cables	Generic name for the following models FX-16E-500CAB-S, FX-16E-□□□CAB, FX-16E-□□□CAB-R, FX-A32E-□□□CAB 150, 300 or 500 is entered in □□□.
Connectors for input/output	Generic name for the following models FX2C-I/O-CON, FX2C-I/O-CON-S, FX2C-I/O-CON-SA
CC-Link master	Generic name for the following models FX3U-16CCL-M, FX2N-16CCL-M
Intelligent device stations	Abbreviation of FX3U-64CCL interface block
Remote I/O stations	Remote stations that handle information in bit units only
Remote device stations	Abbreviation of FX2N-32CCL interface block
Remote stations	Generic name for remote I/O stations and remote device stations
Power supply adapter	Unit to be connected to supply power to the CC-Link/LT system
Dedicated power supply	Power supply to be connected to supply power to the CC-Link/LT system
AS-i master	Abbreviation of model FX2N-32ASI-M AS-i system master block
Peripheral devices	Generic name for programming software, handy programming panel (HPP) and indicator
Programming tool	Generic name for programming software and handy programming panel (HPP)
Programming software	Generic name for GX Works2, GX Developer and FX-PCS/WIN (-E)
GX Works2	Abbreviation of programming software packages SW□DNC-GXW2-J and SW□DNC-GXW2-E
GX Developer	Abbreviation of programming software packages SW□D5C-GPPW-J and SW□D5C-GPPW-E
FX-PCS/WIN (-E)	Abbreviation of programming software packages FX-PCS/WIN and FX-PCS/WIN-E
Handy programming panels (HPP)	Generic name for the following models FX-30P, FX-20P(-E)-SET0, FX-20P(-E), FX-10P-SET0, FX-10P(-E)
USB/RS-422 converters	Abbreviation of FX-USB-AW
RS-232C/RS-422 converters	Generic name for the following models FX-232AW, FX-232AWC, FX-232AWC-H
RS-232C/RS-485 converters	Abbreviation of FX-485PC-IF
Indicators	
GOT1000 Series	Generic name for GT15, GT11 and GT10
GOT-900 Series	Generic name for GOT-A900 Series and GOT-F900 Series
GOT-A900 Series	Generic name for GOT-A900 Series
GOT-F900 Series	Generic name for GOT-F900 Series

Abbreviation/ generic name	Description
Manuals	
FX3U Hardware Edition	Abbreviation of FX3U Series User's Manual - Hardware Edition
Programming manual	Abbreviation of FX3G/FX3U/FX3GC/FX3UC Series Programming Manual - Basic & Applied Instruction Edition
Data Communication Edition	Abbreviation of FX Series User's Manual - Data Communication Edition
Analog Control Edition	Abbreviation of FX3G/FX3U/FX3GC/FX3UC Series User's Manual - Analog Control Edition
Positioning Control Edition	Abbreviation of FX3G/FX3U/FX3GC/FX3UC Series User's Manual - Positioning Control Edition

1 Introduction
2 Features and Part Names
3 Product Introduction
4 Specifications
5 Version and Peripheral Devices
6 System Configuration
7 Input/Output Nos., Unit Nos.
8 Installation
9 Preparation and Power Supply Wiring
10 Input Wiring

2. Features and Part Names

2.1 Major Features

1. Basic functions

[Up to 384 input/output points]

The number of input/output points (up to 256 points) wired directly to the PLC and remote input/output points (up to 256 points) on the network (CC-Link) can be increased to 384 points in total.

[Powered extension units/blocks that can be connected]

FX2N Series input/output powered extension units/blocks can be connected.
Up to 8 FX0N/FX2N/FX3U Series special function units/blocks can be connected.
(Among FX0N Series, only FX0N-3A can be connected.)

[Program memory]

The PLC has a 64K-step RAM memory.
Use of the memory cassette enables the program memory to be used as flash memory.

[Operation instructions]

Various instructions, such as floating-point and character string processing instructions and scaling instructions, are provided.

[Built-in RUN/STOP switch]

The PLC can be started and stopped with the built-in switch.
RUN and STOP commands can be given to the PLC through a general-purpose input terminal or peripheral device.

[Writing during RUN]

The programming software for personal computer enables you to modify the program while the PLC is running.

[Built-in clock function]

The PLC has a clock function to control the time.

[Programming tool]

Use a version of a programming tool supporting the FX3U.

→ Refer to Chapter 5 "Version Information and Peripheral Equipment Connectability" in this manual.

*For peripheral devices not applicable to FX3U Series, specify FX2N Series or FX2 Series for model selection, and you can program the

sequence. In this case, use instructions and devices within the ranges common to FX3U Series and the selected model of PLC.

[Remote debugging of program]

Use of programming software (GX Works2, GX Developer) enables you to remotely transfer programs and monitor PLC operation through a modem connected to the RS-232C expansion board and RS-232C communication special adapter.

2. Input/output high-speed processing functions of main unit

[High-speed counter function]

- 1) Input terminals of main unit
 - Input of open collector transistor output
 - 1-phase 100 kHz x 6 points + 10 kHz x 2 points
 - 2-phase 50 kHz x 2 points
 - 2) Input terminals of high-speed input special adapter (FX3U-4HSX-ADP)
 - Input of differential line driver
 - 1-phase 200 kHz x 8 points (when 2 units are connected)
 - 2-phase 100 kHz x 2 points (when 2 units are connected)
- Refer to Chapter 11 "Use of High-speed Counters (C235 to C255)" in this manual and Programming Manual.

[Pulse catch function]

Signals with short ON width or OFF width can be captured without a complicated program.

→ Refer to Chapter 10 "Input Wiring Procedures (Input Interruption and Pulse Catch)" in this manual and Programming Manual.

Input terminal	Signal ON/OFF width
X000 to X005	5μs
X006, X007	50μs

[Input interruption function (with delay function)]

Interruption routines can be processed preferentially by external signals with the minimum ON or OFF width of 5 μs (X000 to X005).

(Timer interruption and high-speed counter interruption functions are also provided.)

→ **Refer to Chapter 10 "Input Wiring Procedures (Input Interruption and Pulse Catch)" in this manual and Programming Manual.**

[Pulse output function]

1) When output terminals in the transistor output type main unit are used, pulses (open collector outputs) of up to 100 kHz can be output simultaneously to three axes (Y000, Y001 and Y002).

2) When two high-speed output special adapters FX3U-2HSY-ADP are used, pulses (differential line driver outputs) of up to 200 kHz can be output simultaneously to four axes.

→ **Refer to Positioning Control Edition.**

[Various positioning instructions]

→ **Refer to Positioning Control Edition.**

Instruction	Description
DSZR	Mechanical zero return instruction with DOG search function
ABS	Instruction to read the current value from our servo amplifier with absolute position (ABS) detecting function
DRVI	Positioning (relative positioning) to specify the movement from the current position
DRVA	Positioning (absolute positioning) to specify the target position based on the current value 0
PLSV	Instruction to change the pulse train output frequency
DVIT	Positioning for fixed-feed interruption drive
TBL	Instruction for positioning based on batch setting of positioning operation, moving distance and speed

3. Display functions (display module)

FX3U-7DM Display Module (option) can be incorporated in the PLC.

The display module can be mounted on the panel by using the display module holder (option).

[Monitor/test function]

Devices can be monitored and tested by operating the buttons on the display module.

The button operations can be inhibited by the user program.

[Message display function]

User messages can be displayed on the display module by the user program.

[Other functions]

On the display module, you can set the time, adjust the contrast and display the PLC version and error codes.

4. Communication and network functions

The expansion board, special adapter and special function block for each communication function can be connected.

[Kinds of communication functions]

- Programming communication through RS-232C, RS-422 and USB
→ **Refer to Data Communication Edition.**
- N:N Network
→ **Refer to Data Communication Edition.**
- Parallel link
→ **Refer to Data Communication Edition.**
- Computer link
→ **Refer to Data Communication Edition.**
- Inverter communication
→ **Refer to Data Communication Edition.**
- Non-protocol communication through RS-232C/RS-485
→ **Refer to Data Communication Edition.**
- CC-Link
 - Master station (Compatible with CC-Link Ver. 2.00 and Ver. 1.10): FX3U-16CCL-M
 - Master station (Compatible with CC-Link Ver. 1.10): FX2N-16CCL-M
 - Intelligent device station: FX3U-64CCL
 - Remote device station: FX2N-32CCL
→ **Refer to the manual for each product.**
- CC-Link/LT
 - Master station: FX2N-64CL-M
 - Remote I/O station, Remote device station
→ **Refer to the manual for each product.**
- MELSEC I/O LINK
 - Master station: FX2N-16LNK-M
 - Remote I/O station
→ **Refer to the manual for each product.**
- AS-i system
 - Master station: FX2N-32ASI-M
 - Slave station
→ **Refer to the manual for each product.**

5. Analog functions

The special adapter and special function block for each analog function are connected.

→ **For information not given in Analog Control Edition, Refer to the manual for each product.**

[Kinds of analog functions]

- Voltage/current input
- Voltage/current output
- Temperature sensor input (thermocouple and platinum resistance thermometer sensor)
- Temperature control

1	Introduction
2	Features and Part Names
3	Product Introduction
4	Specifications
5	Version and Peripheral Devices
6	System Configuration
7	Input/Output Nos., Unit Nos.
8	Installation
9	Preparation and Power Supply Wiring
10	Input Wiring

2.2 Names and Functions of Parts

2.2.1 Front Panel

Factory default configuration (standard)

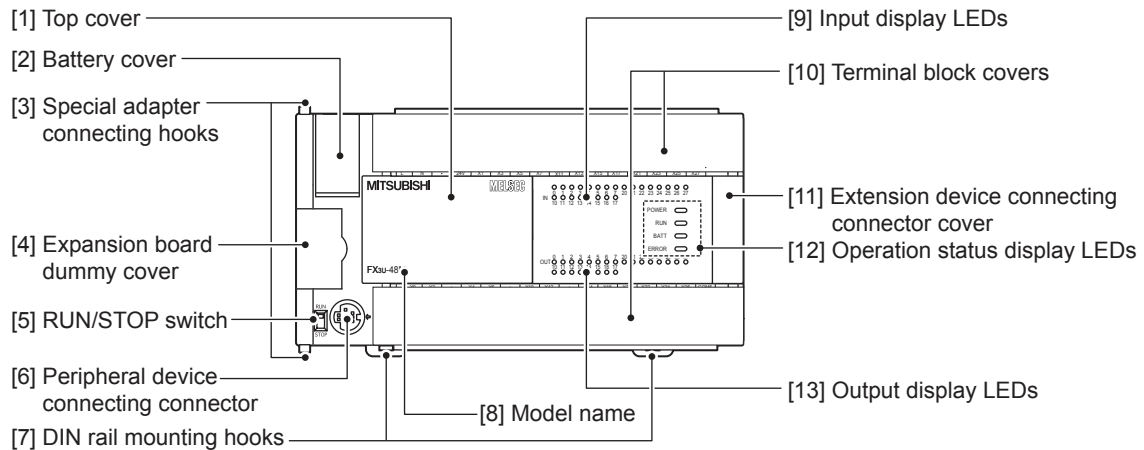

- | | |
|---|--|
| [1] Top cover | Mount the memory cassette under this cover. When FX3U-7DM (display module) is used, replace this cover with the cover supplied with FX3U-7DM. |
| [2] Battery cover | The battery (standard accessory) is set under this cover. When replacing it with a new one, open this cover. |
| [3] Special adapter connecting hooks (2 places) | When connecting the special adapter, secure it with these hooks. |
| [4] Expansion board dummy cover | Remove this dummy cover, and mount an expansion board. |
| [5] RUN/STOP switch | To stop writing (batch) of the sequence program or operation, set the switch to STOP (slide it downward).
To start operation (run the machine), set it to RUN (slide it upward). |
| [6] Peripheral device connecting connector | Connect a programming tool to program a sequence.
→ For details on applicable peripheral devices, refer to Chapter 5. |
| [7] DIN rail mounting hooks | The main unit can be installed on a 35 mm (1.38") wide DIN46277 rail. |
| [8] Model name (abbreviation) | The model name of the main unit is indicated.
Check the nameplate on the right side for the model name. |
| [9] Input display LEDs (red) | When an input terminal (X000 or more) is turned on, the corresponding LED is lit. |
| [10] Terminal block covers | The covers can be opened about 90° for wiring.
Keep the covers closed while the PLC is running (the unit power is on). |
| [11] Extension device connecting connector cover | Connect the extension cables of input/output powered extension unit/block or special function unit/block to the extension device connecting connectors under this cover.
FX3U Series extension devices, FX2N Series extension devices and FX0N Series extension devices can be connected.
→ For details on the extension devices, refer to Chapter 15, Chapter 16 and Section 18.1. |

[12] **Operation status display LEDs**

The operation status of the PLC can be checked with the LEDs. The LEDs turn off, light and flash according to the following table.

→ For details on the operation status, refer to Section 14.5.

LED name	Display color	Description
POWER	Green	On while power is on the PLC.
RUN	Green	On while the PLC is running.
BATT.V	Red	Lights when the battery voltage drops.
ERROR	Red	Flashing when a program error occurs.
	Red	Lights when a CPU error occurs.

[13] **Output display LEDs (red)**

When an output terminal (Y000 or more) is turned on, the corresponding LED is lit.

When the terminal block covers are open

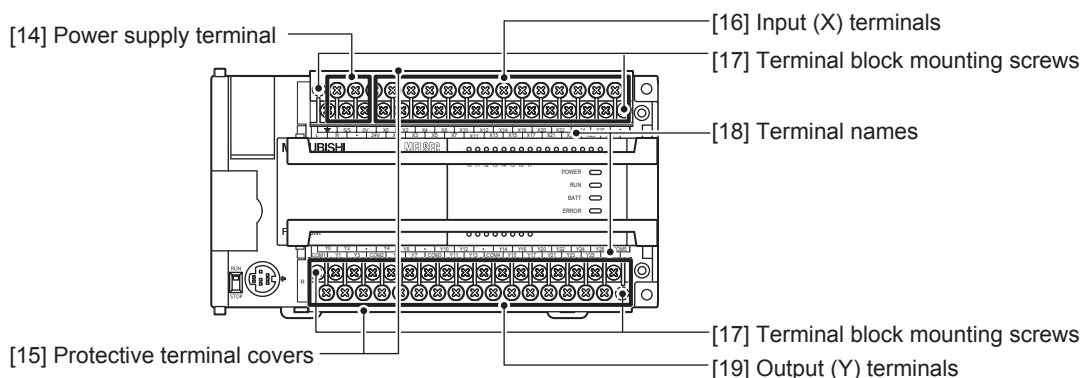

[14] **Power supply terminal**

Connect the power supply to the main unit.

[15] **Protective terminal covers**

A protective terminal cover (refer to the following drawing) is fitted to the lower stage of each terminal block. (FX3U-00M□/ES(S), DS(S), and UA1 are equipped.) The cover prevents fingers from touching terminals, thereby improving safety.



[16] **Input (X) terminals**

Wire switches and sensors to the terminals.

[17] **Terminal block mounting screws**

If the main unit must be replaced, loosen the screws (slightly loosen the left and right screws), and the upper part of the terminal block can be removed. (On FX3U-16M□, the terminal block cannot be removed.)

[18] **Terminal names**

The signal names for power supply, input and output terminals are shown.

[19] **Output (Y) terminals**

Wire loads (contactors, solenoid valves, etc.) to be driven to the terminals.

When the display module (FX3U-7DM) is installed

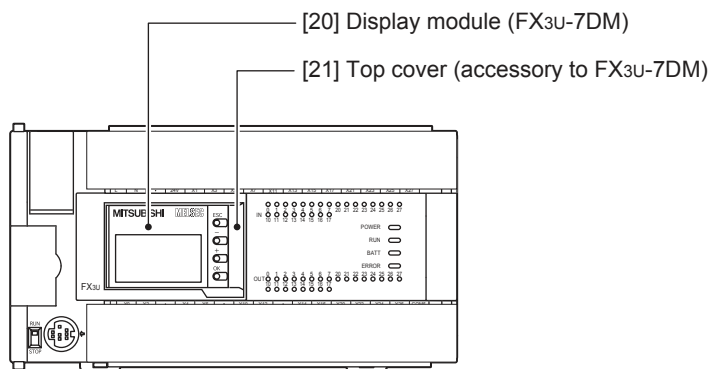

[20] **Display module (FX3U-7DM)**

The display module (option) can be installed.

[21] **Top cover (accessory to FX3U-7DM)**

A square hole is made so that the display module can be seen. Replace the original top cover with this cover.

2.2.2 Sides

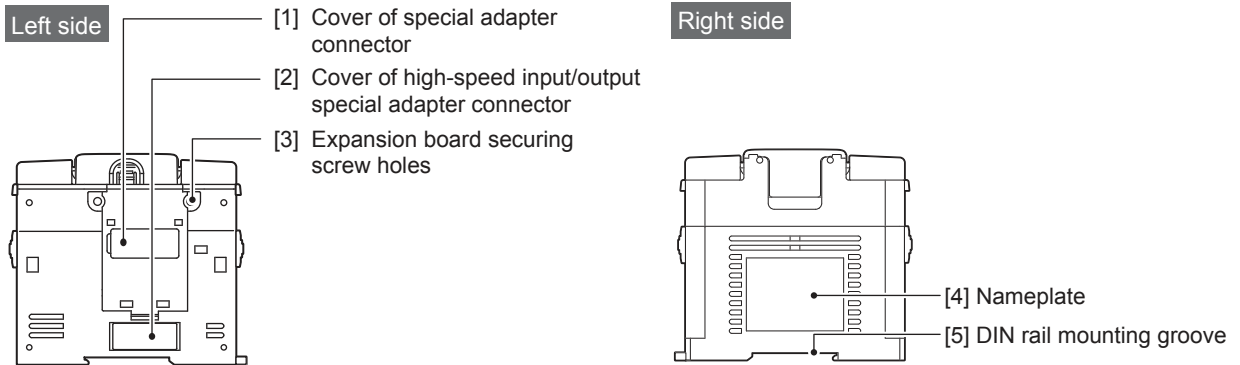

[1] **Cover of special adapter connector**

Remove this cover, and connect the 1st special adapter to the connector (when the expansion board is installed).
When the expansion board is not installed, the connector is not provided.

[2] **Cover of high-speed input/output special adapter connector**

Remove this cover, and connect the first high-speed input special adapter (FX3U-4HSX-ADP) or high-speed output special adapter (FX3U-2HSY-ADP) to the connector. When the communication/analog/CF card special adapter is connected, this connector is not used.

[3] **Expansion board securing screw holes (2 places)**

These holes are designed to secure the expansion board with screws (supplied with the expansion board). The expansion board dummy cover is fitted before shipment. Remove the dummy cover, and fit the board.

[4] **Nameplate**

The product model name, control number and power supply specifications are shown.

→ **For details on the manufacturer's serial number, refer to Subsection 5.1.1.**

[5] **DIN rail mounting groove**

The unit can be installed on a 35 mm (1.38") wide DIN46277 rail.

3. Introduction of Products (Compliant with Overseas Standards)

3.1 List of Products (to be Connected) and Interpretation of Model Names

The following system configuration is classified into product groups A to O in the product introduction sections given below.

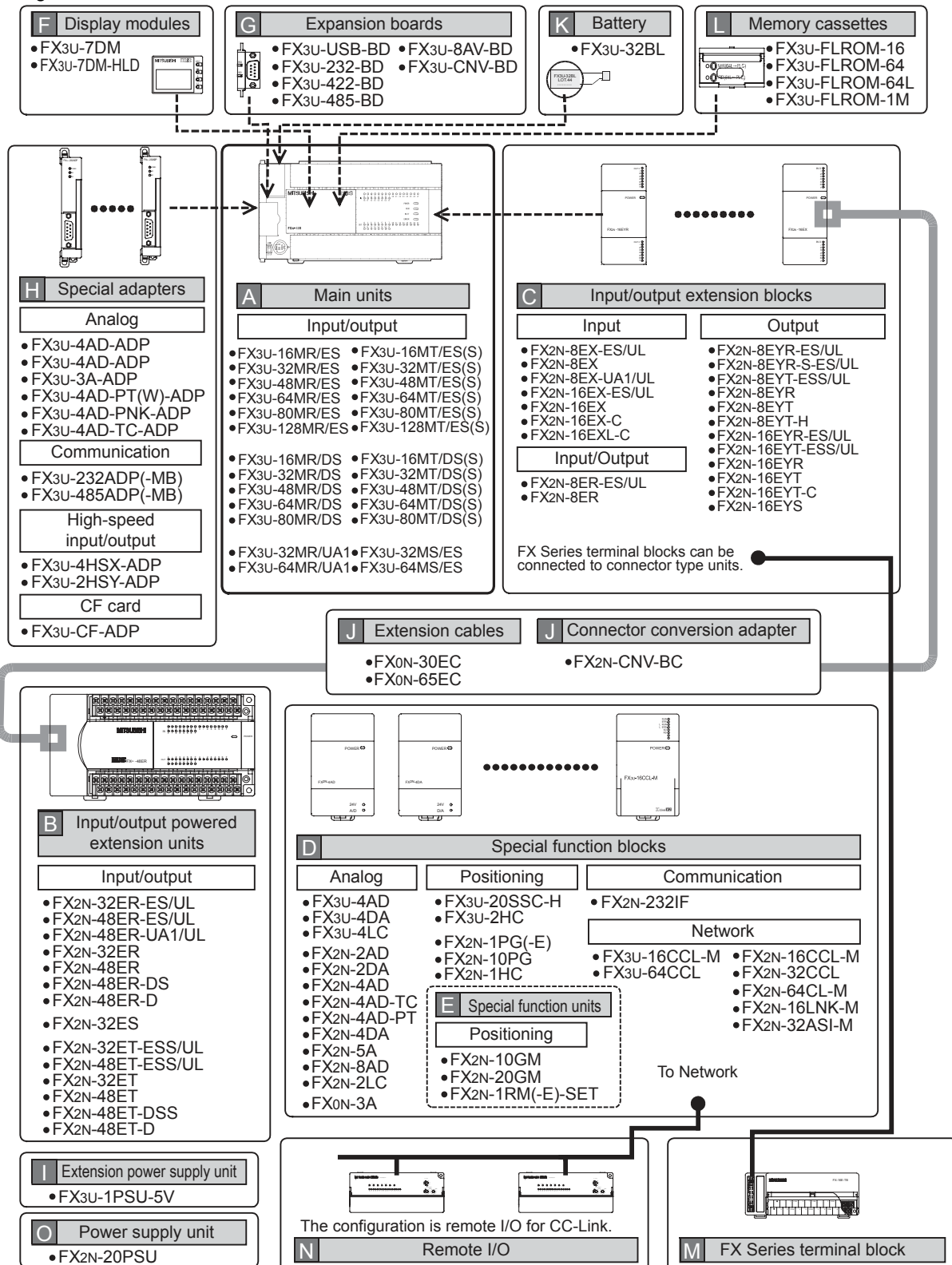

1	Introduction
2	Features and Part Names
3	Product Introduction
4	Specifications
5	Version and Peripheral Devices
6	System Configuration
7	Input/Output Nos., Unit Nos.
8	Installation
9	Preparation and Power Supply Wiring
10	Input Wiring

3.1.1 [A] Main units

A The main unit incorporates a CPU, memory, input and output terminals and power supply. To establish a system, at least one main unit is necessary.

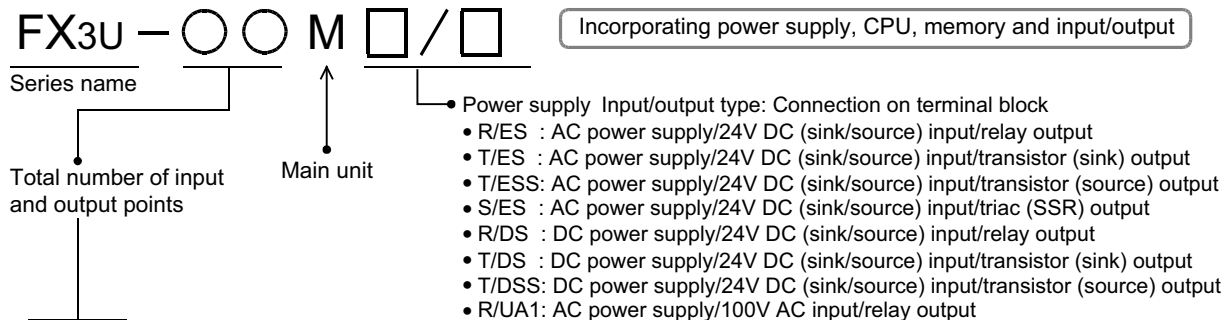

✓ : Compliance with standard or self-declaration □ : Not targeted – : Not applicable

Number of input/output points			Model name	Output type (connection form: terminal block)	CE		UL cUL	Marine
Total number of points	Number of input points	Number of output points			EMC	LVD		
AC power supply common to 24V DC sink and source input								
16	8	8	FX3U-16MR/ES	Relay	✓	✓	✓	*
16	8	8	FX3U-16MT/ES	Transistor (sink)	✓	✓	✓	*
16	8	8	FX3U-16MT/ESS	Transistor (source)	✓	✓	✓	*
32	16	16	FX3U-32MR/ES	Relay	✓	✓	✓	*
32	16	16	FX3U-32MT/ES	Transistor (sink)	✓	✓	✓	*
32	16	16	FX3U-32MT/ESS	Transistor (source)	✓	✓	✓	*
32	16	16	FX3U-32MS/ES	Triac	✓	✓	✓	*
48	24	24	FX3U-48MR/ES	Relay	✓	✓	✓	*
48	24	24	FX3U-48MT/ES	Transistor (sink)	✓	✓	✓	*
48	24	24	FX3U-48MT/ESS	Transistor (source)	✓	✓	✓	*
64	32	32	FX3U-64MR/ES	Relay	✓	✓	✓	*
64	32	32	FX3U-64MT/ES	Transistor (sink)	✓	✓	✓	*
64	32	32	FX3U-64MT/ESS	Transistor (source)	✓	✓	✓	*
64	32	32	FX3U-64MS/ES	Triac	✓	✓	✓	*
80	40	40	FX3U-80MR/ES	Relay	✓	✓	✓	*
80	40	40	FX3U-80MT/ES	Transistor (sink)	✓	✓	✓	*
80	40	40	FX3U-80MT/ESS	Transistor (source)	✓	✓	✓	*
128	64	64	FX3U-128MR/ES	Relay	✓	✓	✓	*
128	64	64	FX3U-128MT/ES	Transistor (sink)	✓	✓	✓	*
128	64	64	FX3U-128MT/ESS	Transistor (source)	✓	✓	✓	*
DC power supply common to 24V DC sink and source input								
16	8	8	FX3U-16MR/DS	Relay	✓	✓	✓	*
16	8	8	FX3U-16MT/DS	Transistor (sink)	✓	□	✓	*
16	8	8	FX3U-16MT/DSS	Transistor (source)	✓	□	✓	*
32	16	16	FX3U-32MR/DS	Relay	✓	✓	✓	*
32	16	16	FX3U-32MT/DS	Transistor (sink)	✓	□	✓	*
32	16	16	FX3U-32MT/DSS	Transistor (source)	✓	□	✓	*
48	24	24	FX3U-48MR/DS	Relay	✓	✓	✓	*
48	24	24	FX3U-48MT/DS	Transistor (sink)	✓	□	✓	*
48	24	24	FX3U-48MT/DSS	Transistor (source)	✓	□	✓	*
64	32	32	FX3U-64MR/DS	Relay	✓	✓	✓	*
64	32	32	FX3U-64MT/DS	Transistor (sink)	✓	□	✓	*
64	32	32	FX3U-64MT/DSS	Transistor (source)	✓	□	✓	*
80	40	40	FX3U-80MR/DS	Relay	✓	✓	✓	*
80	40	40	FX3U-80MT/DS	Transistor (sink)	✓	□	✓	*
80	40	40	FX3U-80MT/DSS	Transistor (source)	✓	□	✓	*

* Please consult with Mitsubishi Electric for information on marine standard practices and the corresponding types of equipment.

→ For more information on CE, UL and cUL, refer to Page 15 or later.

✓ : Compliance with standard or self-declaration □ : Not targeted – : Not applicable

Number of input/output points			Model name	Output type (connection form: terminal block)	CE		UL cUL	Marine
Total number of points	Number of input points	Number of output points			EMC	LVD		
AC power supply only for 100V AC input								
32	16	16	FX3U-32MR/UA1	Relay	✓	✓	✓	*1
64	32	32	FX3U-64MR/UA1	Relay	✓	✓	✓	*1

*1. Please consult with Mitsubishi Electric for information on marine standard practices and the corresponding types of equipment.

→ For more information on CE, UL and cUL, refer to Page 15 or later.

3.1.2 [B] Input/output powered extension units

B The input/output powered extension unit incorporates a power supply circuit and input and output terminals. It is designed to add input and output terminals. It can supply power to extension devices connected on the downstream side.

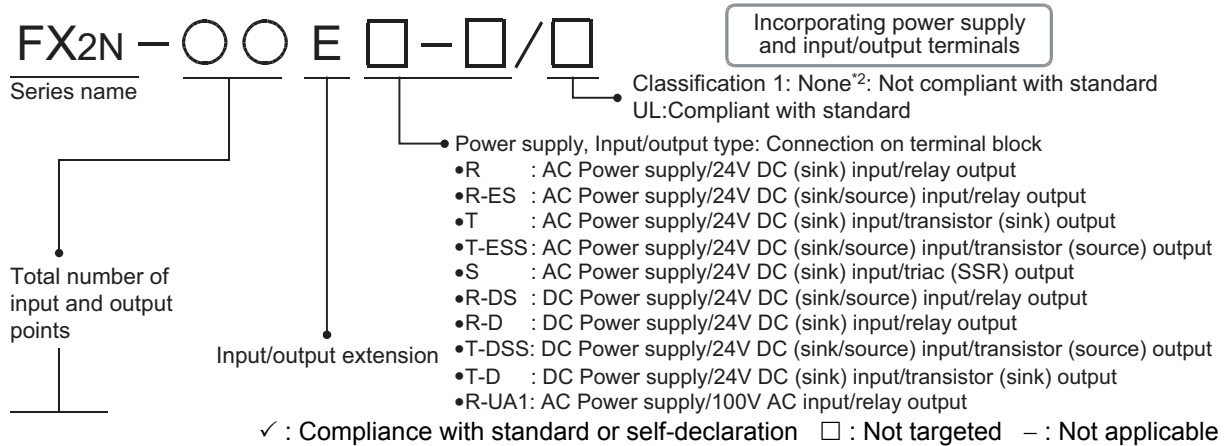

Number of input/output points			Model name	Output type (connection form: terminal block)	CE		UL cUL	Marine
Total number of points	Number of input points	Number of output points			EMC	LVD		
AC power supply common to 24V DC sink and source input								
32	16	16	FX2N-32ER-ES/UL	Relay	✓	✓	✓	*3
32	16	16	FX2N-32ET-ESS/UL	Transistor (source)	✓	✓	✓	*3
48	24	24	FX2N-48ER-ES/UL	Relay	✓	✓	✓	*3
48	24	24	FX2N-48ET-ESS/UL	Transistor (source)	✓	✓	✓	*3
AC power supply only for 24V DC sink input								
32	16	16	FX2N-32ER	Relay	–	–	–	–
32	16	16	FX2N-32ET	Transistor (sink)	–	–	–	–
32	16	16	FX2N-32ES	Triac	–	–	–	–
48	24	24	FX2N-48ER	Relay	–	–	–	–
48	24	24	FX2N-48ET	Transistor (sink)	–	–	–	–
DC power supply common to 24V DC sink and source input								
48	24	24	FX2N-48ER-DS	Relay	✓	✓	✓	–
48	24	24	FX2N-48ET-DSS	Transistor (source)	✓	□	✓	–
DC power supply only for 24V DC sink input								
48	24	24	FX2N-48ER-D	Relay	–	–	–	–
48	24	24	FX2N-48ET-D	Transistor (sink)	–	–	–	–
AC power supply only for 100V AC input								
48	24	24	FX2N-48ER-UA1/UL	Relay	✓	✓	✓	–

*2. FX2N-48ER-DS and FX2N-48ET-DSS comply to UL standard.

*3. Please consult with Mitsubishi Electric for information on marine standard practices and the corresponding types of equipment.

→ For more information on CE, UL and cUL, refer to Page 15 or later.

3.1.3 [C] Input/output extension blocks



The input/output extension block has built-in input or output terminals to add input or output terminals.

FX2N - ○ ○ E □ - □ / □

Series name

Total number of input and output points

Input/output extension

Incorporating input or output terminals

Classification 1: None: Not compliant with standard
UL: Compliant with standard

Input/output type: Connection on terminal block or with connector

- ER : 24V DC(sink)input/relay output/terminal block
- ER-ES : 24V DC(sink/source)input/relay output/terminal block
- X : 24V DC (sink) input/terminal block
- X-C : 24V DC (sink) input/connector
- X-ES : 24V DC (sink/source) input/terminal block
- XL-C : 5V DC input/connector
- X-UA1 : 100V AC input/terminal block
- YR : Relay output/terminal block
- YR-ES : Relay output/terminal block
- YR-S-ES : Relay output (separate reference terminals (Commons))/terminal block
- YT : Transistor (sink) output/terminal block
- YT-H : Transistor (sink) output/terminal block
- YT-C : Transistor (sink) output/connector
- YT-ESS : Transistor (source) output/terminal block
- YS : Triac (SSR) output/terminal block

✓ : Compliance with standard or self-declaration □ : Not targeted - : Not applicable

Number of input/output points			Model name	Input type	Output type	Connection form	CE		UL cUL	Marine
Total number of points	Number of input points	Number of output points					EMC	LVD		
Input/Output extension type										
16*1	4	4	FX2N-8ER-ES/UL	24V DC	Relay	Terminal block	✓	✓	✓	*2
16*1	4	4	FX2N-8ER	24V DC	Relay	Terminal block	-	-	-	-
Input extension type										
8	8	-	FX2N-8EX-ES/UL	24V DC	-	Terminal block	✓	□	✓	*2
8	8	-	FX2N-8EX	24V DC	-	Terminal block	-	-	-	-
8	8	-	FX2N-8EX-UA1/UL	100V AC	-	Terminal block	-	-	✓	-
16	16	-	FX2N-16EX-ES/UL	24V DC	-	Terminal block	✓	□	✓	*2
16	16	-	FX2N-16EX	24V DC	-	Terminal block	-	-	-	-
16	16	-	FX2N-16EX-C	24V DC	-	Connector	-	-	-	-
16	16	-	FX2N-16EXL-C	5V DC	-	Connector	-	-	-	-
Output extension type										
8	-	8	FX2N-8EYR-ES/UL	-	Relay	Terminal block	✓	✓	✓	*2
8	-	8	FX2N-8EYR-S-ES/UL	-	Relay	Terminal block	✓	✓	✓	-
8	-	8	FX2N-8EYT-ESS/UL	-	Transistor (source)	Terminal block	✓	□	✓	*2
8	-	8	FX2N-8EYR	-	Relay	Terminal block	-	-	-	-
8	-	8	FX2N-8EYT	-	Transistor (sink)	Terminal block	-	-	-	-
8	-	8	FX2N-8EYT-H	-	Transistor (sink)	Terminal block	-	-	-	-
16	-	16	FX2N-16EYR-ES/UL	-	Relay	Terminal block	✓	✓	✓	*2
16	-	16	FX2N-16EYT-ESS/UL	-	Transistor (source)	Terminal block	✓	□	✓	*2
16	-	16	FX2N-16EYR	-	Relay	Terminal block	-	-	-	-
16	-	16	FX2N-16EYT	-	Transistor (sink)	Terminal block	-	-	-	-
16	-	16	FX2N-16EYT-C	-	Transistor (sink)	Connector	-	-	-	-
16	-	16	FX2N-16EYS	-	Triac	Terminal block	-	-	✓	-

*1. Four inputs and four outputs are occupied as unused numbers.

*2. Please consult with Mitsubishi Electric for information on marine standard practices and the corresponding types of equipment.

→ For more information on CE, UL and cUL, refer to Page 15 or later.

3.1.4 [D] [E] Special function units/blocks

For details on each product, refer to the product manual.

1. Analog control

✓ : Compliance with standard or self-declaration □ : Not targeted – : Not applicable

Model name	Analog		Description	CE		UL cUL	Marine
	Input	Output		EMC	LVD		
Analog input							
FX3U-4AD	4ch	–	Voltage/current input	✓	□	✓	–
FX2N-2AD	2ch	–	Voltage/current input	✓	□	✓	*
FX2N-4AD	4ch	–	Voltage/current input	✓	□	✓	*
FX2N-8AD	8ch	–	Voltage/current/temperature (thermocouple) input	✓	□	✓	*
FX2N-4AD-PT	4ch	–	Temperature (resistance thermometer sensor) input	✓	□	✓	*
FX2N-4AD-TC	4ch	–	Temperature (thermocouple) input	✓	□	✓	*
Analog output							
FX3U-4DA	–	4ch	Voltage/current output	✓	□	✓	–
FX2N-2DA	–	2ch	Voltage/current output	✓	□	✓	*
FX2N-4DA	–	4ch	Voltage/current output	✓	□	✓	*
Analog input/output mixed							
FX0N-3A	2ch	1ch	Voltage/current input/output	✓	□	–	*
FX2N-5A	4ch	1ch	Voltage/current input/output	✓	□	✓	*
Temperature control							
FX3U-4LC	4 loops	–	Temperature control (resistance thermometer sensor/ thermocouple/micro voltage input)	✓	□	✓	–
FX2N-2LC	2 loops	–	Temperature control (resistance thermometer sensor/ thermocouple)	✓	□	✓	–

* Please consult with Mitsubishi Electric for information on marine standard practices and the corresponding types of equipment.

→ For more information on CE, UL and cUL, refer to Page 15 or later.

2. High-speed counter

✓ : Compliance with standard or self-declaration □ : Not targeted – : Not applicable

Model name	Description	CE		UL cUL	Marine
		EMC	LVD		
FX3U-2HC	2-ch high-speed counter	✓	□	✓	–
FX2N-1HC	1-ch high-speed counter	✓	□	✓	*

* Please consult with Mitsubishi Electric for information on marine standard practices and the corresponding types of equipment.

→ For more information on CE, UL and cUL, refer to Page 15 or later.

3. Pulse output and positioning

✓ : Compliance with standard or self-declaration □ : Not targeted – : Not applicable

D
E

Model name	Description	CE		UL cUL	Marine
		EMC	LVD		
FX2N-1PG D	Pulse output for independent 1-axis control (manual in Japanese supplied) [100 kHz open collector output]	–	–	–	–
FX2N-1PG-E D	Pulse output for independent 1-axis control (manual in English supplied) [100 kHz open collector output]	✓	□	✓	*2
FX2N-10PG D	Pulse output for independent 1-axis control [1 MHz differential line driver output]	✓	□	✓	–
FX3U-20SSC-H D	Simultaneous 2-axis (independent 2-axis) control [Applicable to SSCNET III]	✓	□	✓*3	–
FX2N-10GM E	Pulse output for independent 1-axis control [200 kHz open collector output]	✓	□	✓	–
FX2N-20GM E	Pulse output for simultaneous 2-axis (independent 2-axis) control [200 kHz open collector output]	✓	□	✓	–
FX2N-1RM-SET E *1	1-axis programmable cam switch (manual in Japanese supplied)	–	–	–	–
FX2N-1RM-E-SET E *1	1-axis programmable cam switch (manual in English supplied)	✓	□	–	*2

→ For more information on CE, UL and cUL, refer to Page 15 or later.

- *1. Up to 3 units can be connected to one system. Connect them to the end of the system. For details, refer to FX2N-1RM(-E)-SET Handy Manual.

Number of connected units	Number of input/output points occupied	Count of number of connected special function units/blocks
1 unit	8 points	1
2 units		
3 units		

- *2. Please consult with Mitsubishi Electric for information on marine standard practices and the corresponding types of equipment.
*3. Products manufactured in and after June, 2006 will comply with the UL and cUL standards.

4. Data link and communication functions

✓ : Compliance with standard or self-declaration □ : Not targeted – : Not applicable

D

Model name	Description	CE		UL cUL	Marine
		EMC	LVD		
FX2N-232IF	1-ch RS-232C non-protocol communication	✓	□	–	*
FX3U-16CCL-M	Master for CC-Link (Compatible with Ver. 2.00 and Ver. 1.10) Connectable stations: Remote I/O station, Remote device station, Intelligent device station	✓	□	✓	–
FX2N-16CCL-M	Master for CC-Link (Compatible with Ver. 1.10) Connectable stations: Remote I/O station, Remote device station	✓	□	–	–
FX3U-64CCL	CC-Link interface (Intelligent device station) [1 to 4 stations occupied]	✓	□	✓	–
FX2N-32CCL	CC-Link interface (Remote device station) [1 to 4 stations occupied]	✓	□	–	–
FX2N-64CL-M	Master for CC-Link/LT	✓	□	✓	–
FX2N-16LNK-M	Master for MELSEC I/O Link	✓	✓	✓	–
FX2N-32ASI-M	Master for AS-i system	✓	□	–	–

- * Please consult with Mitsubishi Electric for information on marine standard practices and the corresponding types of equipment.

→ For more information on CE, UL and cUL, refer to Page 15 or later.

3.1.5 [F] Display modules and holder

✓ : Compliance with standard or self-declaration □ : Not targeted - : Not applicable

Model name	Description	CE		UL cUL	Marine
		EMC	LVD		
FX3U-7DM	Display module that can be incorporated in FX3U Series main unit	✓*1	□	-	*2
FX3U-7DM-HLD	Holder and extension cable to fit FX3U-7DM display module on panel	-	-	-	-
FX-10DM(-SET0)	Display module to be connected to peripheral device connector with cable (manual in Japanese supplied)	-	-	-	-
FX-10DM-E	Display module to be connected to peripheral device connector with cable (manual in English supplied)	✓	□	-	-

*1. Products manufactured in and after May, 2005 will comply with the overseas standard.

*2. Please consult with Mitsubishi Electric for information on marine standard practices and the corresponding types of equipment.

→ For more information on CE, UL and cUL, refer to Page 15 or later.

3.1.6 [G] Expansion boards

✓ : Compliance with standard or self-declaration □ : Not targeted - : Not applicable

Model name	Description	CE		UL cUL	Marine
		EMC	LVD		
FX3U-CNV-BD	Conversion of connector for fitting special adapter	✓*1	□	-	*2
FX3U-232-BD	For RS-232C communication	✓*1	□	-	*2
FX3U-422-BD	For RS-422 communication (having the same function as that of peripheral device connector incorporated in main unit)	✓*1	□	-	*2
FX3U-485-BD	For RS-485 communication	✓*1	□	-	*2
FX3U-USB-BD	For USB communication (for personal computer for programming)	✓*1	□	-	*2
FX3U-8AV-BD	For 8ch analog volume	✓	□	-	-

*1. Products manufactured in and after June, 2005 will comply with the overseas standard.

*2. Please consult with Mitsubishi Electric for information on marine standard practices and the corresponding types of equipment.

→ For more information on CE, UL and cUL, refer to Page 15 or later.

3.1.7 [H] Special adapters

1. Analog functions

✓ : Compliance with standard or self-declaration □ : Not targeted – : Not applicable

[H]	Model name	Description	CE		UL cUL	Marine
			EMC	LVD		
	FX3U-4AD-ADP	4-ch voltage input/current input	✓*1	□	✓*1	*2
	FX3U-4DA-ADP	4-ch voltage output/current output	✓*1	□	✓*1	*2
	FX3U-3A-ADP	2-ch voltage input/current input 1-ch voltage output/current output	✓	□	✓	–
	FX3U-4AD-PT-ADP	4-ch platinum resistance thermometer sensor input	✓*1	□	✓*1	*2
	FX3U-4AD-PTW-ADP	4-ch platinum resistance thermometer sensor input (-100 to 600°C)	✓	□	✓	–
	FX3U-4AD-PNK-ADP	4-ch temperature sensor input (Pt1000/Ni1000 resistance thermometer sensor) input	✓	□	✓	–
	FX3U-4AD-TC-ADP	4-ch thermocouple (K, J type) temperature sensor input	✓*1	□	✓*1	*2

*1. Products manufactured in and after June, 2005 will comply with the overseas standard.

*2. Please consult with Mitsubishi Electric for information on marine standard practices and the corresponding types of equipment.

→ For more information on CE, UL and cUL, refer to Page 15 or later.

2. Communication functions

✓ : Compliance with standard or self-declaration □ : Not targeted – : Not applicable

[H]	Model name	Description	CE		UL cUL	Marine
			EMC	LVD		
	FX3U-232ADP-MB	RS-232C communication	✓	□	✓	*2
	FX3U-485ADP-MB	RS-485 communication	✓	□	✓	*2
	FX3U-232ADP	RS-232C communication	✓*1	□	✓*1	*2
	FX3U-485ADP	RS-485 communication	✓*1	□	✓*1	*2

*1. Products manufactured in and after June, 2005 will comply with the overseas standard.

*2. Please consult with Mitsubishi Electric for information on marine standard practices and the corresponding types of equipment.

→ For more information on CE, UL and cUL, refer to Page 15 or later.

3. CF card functions

✓ : Compliance with standard or self-declaration □ : Not targeted – : Not applicable

[H]	Model name	Description	CE		UL cUL	Marine
			EMC	LVD		
	FX3U-CF-ADP	CF card special adapter	✓	□	✓	–

→ For more information on CE, UL and cUL, refer to Page 15 or later.

4. High-speed input/output functions

✓ : Compliance with standard or self-declaration □ : Not targeted – : Not applicable

Model name	Description	CE		UL cUL	Marine
		EMC	LVD		
FX3U-4HSX-ADP	For differential line driver input (for high-speed counter)	✓	□	✓	*
FX3U-2HSY-ADP	For differential line driver output (for positioning output)	✓	□	✓	*

* Please consult with Mitsubishi Electric for information on marine standard practices and the corresponding types of equipment.

→ For more information on CE, UL and cUL, refer to Page 15 or later.

3.1.8 [I] Extension power supply unit

✓ : Compliance with standard or self-declaration □ : Not targeted – : Not applicable

Model name	Description	Driving power supply	CE		UL cUL	Marine
			EMC	LVD		
FX3U-1PSU-5V	Extension power supply 5V DC 1A	100 to 240V AC	✓	✓	✓	–

→ For more information on CE, UL and cUL, refer to Page 15 or later.

3.1.9 [J] Extension cables and connector conversion adapter [K] Battery [L] Memory cassettes

✓ : Compliance with standard or self-declaration □ : Not targeted – : Not applicable

Classification	Model name	Description		CE		UL cUL	Marine
				EMC	LVD		
Extension cables [J]	FX0N-65EC*1	0.65m (2'1")	These cables are used to mount input/output extension units/blocks for FX2N and special function units/blocks (except for the FX2N-10GM and FX2N-20GM) away from the main unit.	–	–	–	–
	FX0N-30EC*1	0.3m (0'11")		–	–	–	–
	FX2N-GM-65EC	0.65m (2'1")	This cable is used when FX2N-10GM or FX2N-20GM is mounted at the top of the extension units/blocks.	–	–	–	–
Connector conversion adapter [J]	FX2N-CNV-BC	Connector conversion adapter to connect input/output extension blocks for FX2N and special function blocks with model FX0N-30/65EC extension cable		–	–	–	–
Battery [K]	FX3U-32BL	This battery backs up the following data. • Program memory in built-in RAM • Keep devices (battery backup devices) • Results of sampling trace • Time on clock		–	–	–	–
Memory cassettes [L]	FX3U-FLROM-16	16k-step flash memory		✓	□	–	*3
	FX3U-FLROM-64	64k-step flash memory		✓*2	□	–	*3
	FX3U-FLROM-64L	64k-step flash memory (with transfer switch)		✓	□	–	*3
	FX3U-FLROM-1M	64k-step flash memory (There is an area dedicated to the storage of symbolic information.)		✓	□	–	*3

*1. When the extension cable (FX0N-30EC or FX0N-65EC) is used, use up to one cable for one system. When an extension block is added, use FX2N-CNV-BC in addition to the cable. These extension cables are unusable for FX2N-10GM and FX2N-20GM.

*2. Products manufactured in and after June, 2005 will comply with the overseas standard.

*3. Please consult with Mitsubishi Electric for information on marine standard practices and the corresponding types of equipment.

→ For more information on CE, UL and cUL, refer to Page 15 or later.

3.1.10 [M] FX Series terminal blocks (cables and connectors)

1. FX Series terminal blocks

✓ : Compliance with standard or self-declaration □ : Not targeted – : Not applicable

Model name	Number of input points	Number of output points	Function	CE		UL cUL	Marine
				EMC	LVD		
FX-16E-TB	16 input points or 16 output points		To be directly connected to the PLC input/output connector	–	–	✓	–
FX-32E-TB	32 input points, 32 output points or 16 input/output points			–	–	✓	–
FX-16EX-A1-TB	16	–	100V AC input	–	–	✓	–
FX-16EYR-TB	–	16	Relay output	–	–	✓	–
FX-16EYS-TB	–	16	Triac output	–	–	–	–
FX-16EYT-TB	–	16	Transistor output (sink)	–	–	✓	–
FX-16EYT-H-TB	–	16	Transistor output (sink)	–	–	–	–

→ For more information on CE, UL and cUL, refer to Page 15 or later.

2. Input/output cables

Model name	Shape
FX-16E-500CAB-S	5m(16'4") • Single wire (Wire color: red) • PLC side: A 20-pin connector
FX-16E-150CAB	1.5m(4'11") • Flat cables (with tube) • A 20-pin connector at both ends
FX-16E-300CAB	
FX-16E-500CAB	
FX-16E-150CAB-R	1.5m(4'11") • Round multicore cables • A 20-pin connector at both ends
FX-16E-300CAB-R	
FX-16E-500CAB-R	
FX-A32E-150CAB	1.5m(4'11") • Flat cables (with tube) • PLC side: Two 20-pin connectors in 16-point units. • Terminal block side: A dedicated connector • One common terminal covers 32 input/output terminals.
FX-A32E-300CAB	
FX-A32E-500CAB	

3. Input/output connector

Model name	Function
FX2c-I/O-CON	10-piece set Input/output connector for flat cable
FX2c-I/O-CON-S	5-piece set Input/output connector for bulk wire for 0.3 mm ² [AGW22]
FX2c-I/O-CON-SA	5-piece set Input/output connector for bulk wire for 0.5 mm ² [AGW20]

3.1.11 [N] Remote I/O

[N] For the remote I/O of CC-Link, CC-Link/LT and AS-i system, refer to the manual and catalog of each master.

3.1.12 [O] Power supply unit

✓ : Compliance with standard or self-declaration □ : Not targeted – : Not applicable

Model name	Description	Driving power supply	CE		UL cUL	Marine
			EMC	LVD		
FX2N-20PSU	24V DC power supply	100 to 240V AC	✓	✓	✓	–

→ For more information on CE, UL and cUL, refer to Page 15 or later.

3.2 Connector Types and Cables for Program Communication

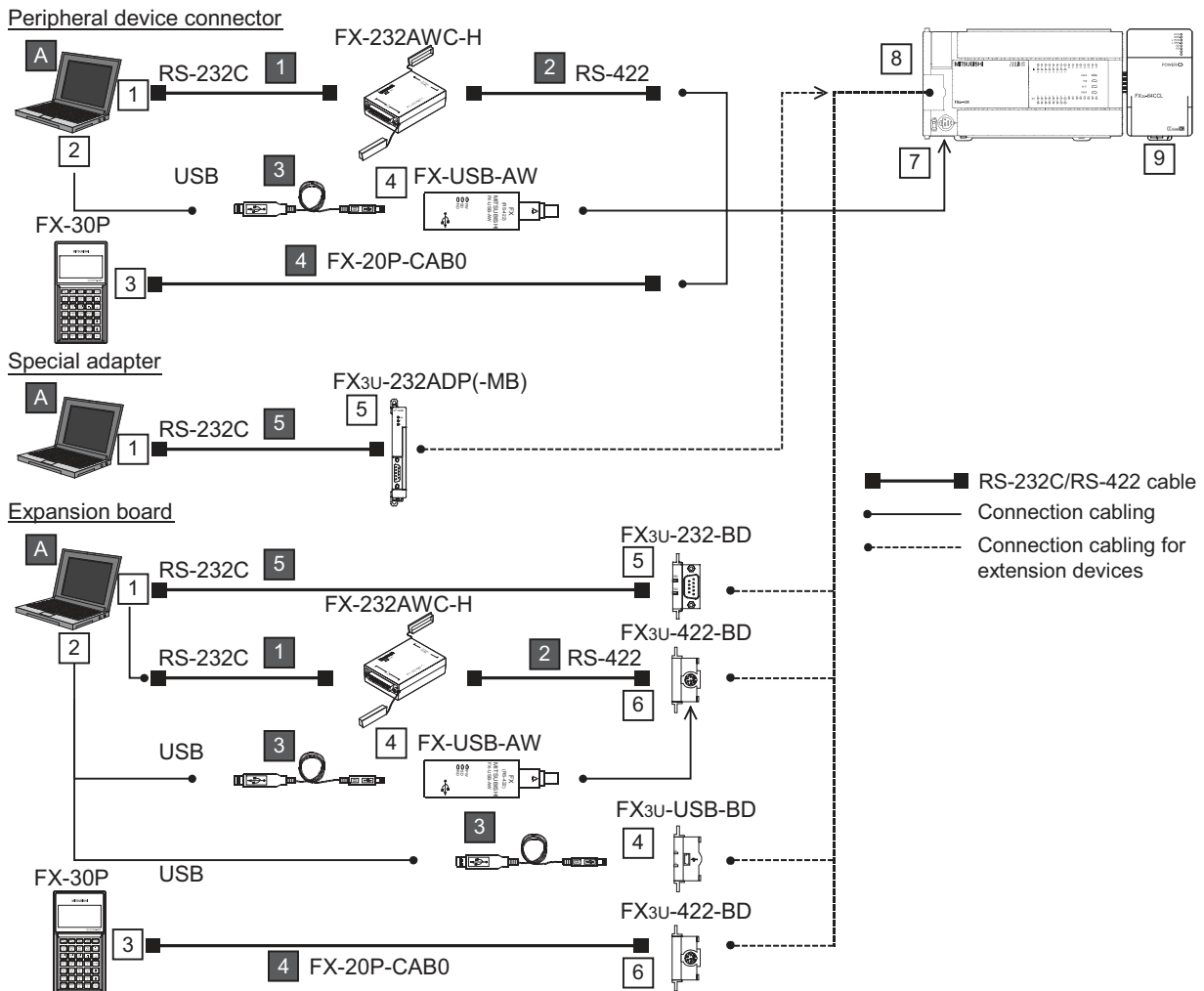

No.	Shape of connector or combination with cable	No.	Shape of connector or combination with cable
1	D-SUB 9Pin	2 "FX-422CAB0" + 1 "F2-232CAB-1" + "FX-232AW/FX-232AWC/FX-232AWC-H"	3 FX-30PMINI DIN 8Pin [RS-422] 4 FX-20P-CAB0
		5 FX-232CAB-1	4 FX3u-USB-BD USB MINI B connector female [USB2.0] FX-USB-AW USB MINI B connector female [USB2.0]
	Half pitch 14Pin	2 "FX-422CAB0" + 1 "F2-232CAB-2" + "FX-232AW/FX-232AWC/FX-232AWC-H"	5 FX3u-232-BD D-SUB 9Pin [RS-232C] FX3u-232ADP(-MB) D-SUB 9Pin [RS-232C]
		5 FX-232CAB-2	6 FX3u-422-BD MINI DIN 8Pin [RS-422]
D-SUB 25Pin	2 "FX-422CAB0" + 1 "F2-232CAB" + "FX-232AW/FX-232AWC/FX-232AWC-H"	7 Peripheral device connector [RS-422] MINI DIN 8Pin	
	5 F2-232CAB-1	8 Expansion board (special adapter) connector	
2	USB A connector, female	3 USB cable (supplied with FX-USB-AW or FX3u-USB-BD)	9 FX3u-64CCL CC-Link connection terminal block For details, refer to the FX3u-64CCL user's manual.

*1. When FX-232AW or FX-232AWC is used, the communication baud rate is 19,200 bps or less.
→ For details, refer to Subsection 3.2.3.

1	Introduction
2	Features and Part Names
3	Product Introduction
4	Specifications
5	Version and Peripheral Devices
6	System Configuration
7	Input/Output Nos., Unit Nos.
8	Installation
9	Preparation and Power Supply Wiring
10	Input Wiring

3.2.1 Programming tool

The following programming tool supports FX3U Series PLCs.

Model name	Description
GX Works2	Version 1.07H or later of SW□DNC-GXW2-J supports the FX3U. Version 1.08J or later of SW□DNC-GXW2-E supports the FX3U.
GX Developer	Version 8.23Z or later of SW□D5C-GPPW-J supports the FX3U. Version 8.24A or later of SW□D5C-GPPW-E supports the FX3U. Although versions earlier than 8.23Z(-J) or 8.24A(-E) can be used for programming by selecting the model "FX3U(C)" or "FX2N(C)", restrictions apply.
FX-30P	FX-30P supports from the first version.

→ For more information, refer to Chapter 5 "Version Information and Peripheral Equipment Connectability".

3.2.2 Communication cables

✓ : Compliance with standard or self-declaration □ : Not targeted – : Not applicable

1	Model name	Description	CE		UL cUL	Marine	
			EMC	LVD			
2	USB cable						
3	USB cable 3	3m (9'10")	USB A plug ↔ USB MINI B plug				
4			For connection between personal computer and FX3U-USB-BD USB cable (3m(9'10")) supplied with FX3U-USB-BD or commercially available cable (up to 5m(16'4"))	–	–	–	–
	RS-232C cable						
	F2-232CAB-1 1	3m (9'10")	D-SUB 9Pin ↔ D-SUB 25Pin	–	–	–	–
	F2-232CAB 1	3m (9'10")	D-SUB 25Pin ↔ D-SUB 25Pin	–	–	–	–
	F2-232CAB-2 1	3m (9'10")	Half-pitch 14-pin ↔ D-SUB 25Pin	–	–	–	–
	FX-232CAB-1 4	3m (9'10")	D-SUB 9Pin ↔ D-SUB 9Pin	–	–	–	–
	FX-232CAB-2 4	3m (9'10")	Half-pitch14Pin ↔ D-SUB 9Pin	–	–	–	–
	RS-422 cable						
	FX-422CAB0 2	1.5m (4'11")	D-SUB 25Pin ↔ MINI DIN 8Pin	–	–	–	–

3.2.3 Converters and interface

✓ : Compliance with standard or self-declaration □ : Not targeted – : Not applicable

Model name	Description	CE		UL cUL	Marine
		EMC	LVD		
RS-232C/RS-422 Converters					
FX-232AWC-H*1	RS-232C/RS-422 converter (high-speed type) Communication speed: Applicable to 9,600 to 115,000 bps .	✓*2	□	–	–
FX-232AW	RS-232C/RS-422 converters	–	–	–	–
FX-232AWC	Communication speed: Applicable to 9,600/19,200 bps	–	–	–	–
USB Interface					
FX-USB-AW*1	USB-RS-422 converter (with 3m(9'10") USB cable)	✓*3	□	–	–

*1. When the programming software is not applicable to FX3U or FX3UC, the converter is applicable only to 9,600 or 19,200 bps.

*2. Products manufactured in and after July, 2004 conform to the overseas standard.

*3. Products manufactured in and after August, 2004 conform to the overseas standard.

1	Introduction
2	Features and Part Names
3	Product Introduction
4	Specifications
5	Version and Peripheral Devices
6	System Configuration
7	Input/Output Nos., Unit Nos.
8	Installation
9	Preparation and Power Supply Wiring
10	Input Wiring

4. Specifications, External Dimensions and Terminal Layout (Main Units)

This Chapter explains the specifications, external dimensions and terminal layout of the main units.

→ For input/output powered extension unit specifications, refer to Chapter 15.

→ For input/output extension block specifications, refer to Chapter 16.

4.1 Generic Specifications

Item	Specification				
Ambient temperature	0 to 55°C (32 to 131°F) when operating and -25 to 75°C (-13 to 167°F) when stored				
Ambient humidity	5 to 95%RH (no condensation) when operating				
Vibration resistance*1		Frequency (Hz)	Acceleration (m/s ²)	Half amplitude (mm)	Sweep Count for X, Y, Z: 10 times (80 min in each direction)
	When installed on DIN rail	10 to 57	–	0.035	
		57 to 150	4.9	–	
	When installed directly	10 to 57	–	0.075	
57 to 150		9.8	–		
Shock resistance*1	147 m/s ² Acceleration, Action time: 11ms, 3 times by half-sine pulse in each direction X, Y, and Z				
Noise resistance	By noise simulator at noise voltage of 1,000 Vp-p, noise width of 1 μs, rise time of 1 ns and period of 30 to 100 Hz				
Dielectric withstand voltage*3	1.5kV AC for one minute		Between each terminals and ground terminal		
	500V AC for one minute				
Insulation resistance*3	5MΩ or more by 500V DC megger				
Grounding	Class D grounding (grounding resistance: 100 Ω or less) <Common grounding with a heavy electrical system is not allowed>*2				
Working atmosphere	Free from corrosive or flammable gas and excessive conductive dust				
Working altitude	<2000m*4				

*1. The criterion is shown in IEC61131-2.

*2. Ground the PLC independently or jointly.

→ Refer to Section 9.4.

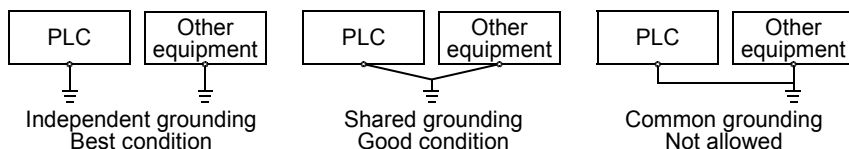

*3. For more information on the dielectric withstand voltage test and the insulation resistance test of the terminals of each product, refer to the following.

→ Refer to Subsection 4.1.1.

*4. Do not use the PLC under pressure higher than the atmospheric pressure. Doing so may damage the PLC.

4.1.1 Dielectric withstand voltage test and insulation resistance test

Perform dielectric withstand voltage test and insulation resistance test at the following voltage between each terminals and the main unit ground terminal.

Between terminals	Dielectric strength	Insulation resistance	Remarks
Terminals of main unit and input/output powered extension unit/block			
• Between power supply terminal (AC power supply) and ground terminal	1.5kV AC for 1 min	5M Ω or more on 500V DC Megger	-
• Between power supply terminal (DC power supply) and ground terminal	500V AC for 1 min		-
• Between 24V DC service power supply connected to input terminal (24V DC) and ground terminal	500V AC for 1 min		-
• Between input terminal (100V AC) and ground terminal	1.5kV AC for 1 min		-
• Between output terminal (relay) and ground terminal	1.5kV AC for 1 min		-
• Between output terminal (transistor) and ground terminal	500V AC for 1 min		-
• Between output terminal (triac) and ground terminal	1.5kV AC for 1 min		-
Terminals of expansion board, special adapter and special function unit/block			
• Between terminal of expansion board (except for the FX3U-USB-BD and FX3U-CNV-BD) and ground terminal	Not allowed	Not allowed	Since the expansion board and the main unit CPU are not insulated, it is not allowed to perform the dielectric withstand voltage test and insulation resistance test between them.
• Between terminal of expansion board (FX3U-USB-BD) and ground terminal	Not allowed	Not allowed	Do not perform the dielectric withstand voltage test and insulation resistance test between the communication line and the main unit CPU.
• Between terminal of special adapter and ground terminal	500V AC for 1 min	5M Ω or more on 500V DC Megger	-
• Special function unit/block	Each manual		Refer to the manual for each special function unit/block.

1	Introduction
2	Features and Part Names
3	Product Introduction
4	Specifications
5	Version and Peripheral Devices
6	System Configuration
7	Input/Output Nos., Unit Nos.
8	Installation
9	Preparation and Power Supply Wiring
10	Input Wiring

4.2 Power Supply Specifications

The specifications for the main unit power supply are explained below.

For the power (current) consumed by the special function units/blocks, refer to this manual or the special function units/blocks manual.

4.2.1 AC Power Supply/DC Input Type

Item	Specifications					
	FX3U-16M□/ E□	FX3U-32M□/ E□	FX3U-48M□/ E□	FX3U-64M□/ E□	FX3U-80M□/ E□	FX3U-128M□/ E□
Supply voltage	100 to 240V AC					
Allowable supply voltage range	85 to 264V AC					
Rated frequency	50 / 60 Hz					
Allowable instantaneous power failure time	Operation can be continued upon occurrence of instantaneous power failure for 10 ms or less. When the supply voltage is 200V AC, the time can be change to 10 to 100 ms by editing the user program.					
Power fuse	250V, 3.15A			250V, 5A		
Rush current	30 A max. 5 ms or less/100V AC, 65 A max. 5 ms or less/200V AC					
Power consumption *1	30 W	35 W	40 W	45 W	50 W	65 W
24V DC service power supply *2	400 mA or less			600 mA or less		
5V DC built-in power supply *3	500 mA or less					

*1. These power consumption values are maximum values which apply to the main unit's 24V DC service power supply when there are input/output extension blocks and special function units/blocks.
→ **For input/output powered extension units/blocks power consumption information, refer to Section 15.2.**

*2. When input/output extension blocks are connected, 24V DC service power is consumed by the blocks, and the power to be consumed by the main unit is reduced.
→ **For details on 24V DC service power supply, refer to Section 6.5.**

*3. The power supply is not for external use.
The current capacity specified above is for the input/output extension blocks, special function blocks, special adapters and expansion boards.

4.2.2 DC Power Supply/DC Input Type

Item	Specifications				
	FX3U-16M□/D□	FX3U-32M□/D□	FX3U-48M□/D□	FX3U-64M□/D□	FX3U-80M□/D□
Supply voltage	24V DC				
Allowable supply voltage range	16.8 to 28.8V DC ^{*3}				
Allowable instantaneous power failure time	Operation can be continued upon occurrence of instantaneous power failure for 5 ms or less.				
Power fuse	250V, 3.15A		250V, 5A		
Rush current	35 A max. 0.5 ms or less/24V DC				
Power consumption ^{*1}	25 W	30 W	35 W	40 W	45 W
24V DC service power supply	-				
5V DC built-in power supply ^{*2}	500 mA or less				

- *1. This power consumption is the value maximized by input/output extension blocks and special function units/blocks connected to the main unit.
→ For input/output powered extension units/blocks power consumption information, refer to Section 15.2.
- *2. The power supply is not for external use.
The current capacity specified above is for the input/output extension blocks, special function blocks, special adapters and expansion boards.
- *3. When supply voltage is 16.8 to 19.2V DC, the connectable extension equipment decreases.
For details, refer to Subsection 6.5.3 or 6.5.4.

4.2.3 AC Power Supply/AC Input Type

Item	Specifications	
	FX3U-32MR/UA1	FX3U-64MR/UA1
Supply voltage	100 to 240V AC	
Allowable supply voltage range	85 to 264V AC	
Rated frequency	50/60 Hz	
Allowable instantaneous power failure time	Operation can be continued upon occurrence of instantaneous power failure for 10 ms or less. When the supply voltage is 200V AC, the time can be change to 10 to 100 ms by editing the user program.	
Power fuse	250V, 5A	
Rush current	30 A max. 5 ms or less/100V AC, 65A max. 5 ms or less/200V AC	
Power consumption ^{*1}	35 W	45 W
24V DC service power supply	-	
5V DC built-in power supply ^{*2}	500 mA or less	

- *1. This power consumption is the value maximized by input/output extension blocks and special function units/blocks connected to the main unit.
→ For input/output powered extension units/blocks power consumption information, refer to Section 15.2.
- *2. The power supply is not for external use.
The current capacity specified above is for the input/output extension blocks, special function blocks, special adapters and expansion boards.

1	Introduction
2	Features and Part Names
3	Product Introduction
4	Specifications
5	Version and Peripheral Devices
6	System Configuration
7	Input/Output Nos., Unit Nos.
8	Installation
9	Preparation and Power Supply Wiring
10	Input Wiring

4.3 Input Specifications

The main unit input specifications are explained below.

4.3.1 24V DC input (sink/source) type

The input numbers in the table indicate the main unit terminal numbers. "X010 or more" means the numbers from X010 to the largest number that the main unit has.
(The input numbers for FX3U-16M□ are X000 to X007.)

→ For details on input and source input, refer to Subsection 10.1.1.

Item	Specifications					
	FX3U-16M□/ □S(S)	FX3U-32M□/ □S(S)	FX3U-48M□/ □S(S)	FX3U-64M□/ □S(S)	FX3U-80M□/ □S(S)	FX3U-128M□/ □S(S)
Number of input points	8 points	16 points	24 points	32 points	40 points	64 points
Input connecting type	Fixed terminal block (M3 screw)	Removable terminal block (M3 screw)				
Input form	sink/source					
Input signal voltage	AC power type: 24V DC ±10% DC power type: 16.8 to 28.8V DC					
Input impedance	X000 to X005	3.9 kΩ				
	X006,X007	3.3 kΩ				
	X010 or more	–	4.3 kΩ			
Input signal current	X000 to X005	6 mA / 24V DC				
	X006,X007	7 mA / 24V DC				
	X010 or more	–	5 mA / 24V DC			
ON input sensitivity current	X000 to X005	3.5 mA or more				
	X006,X007	4.5 mA or more				
	X010 or more	–	3.5 mA or more			
OFF input sensitivity current	1.5 mA or less					
Input response time	Approx. 10 ms					
Input signal form	No-voltage contact input Sink input: NPN open collector transistor Source input: PNP open collector transistor					
Input circuit insulation	Photocoupler insulation					
Input operation display	LED on panel lights when photocoupler is driven.					
Input circuit configuration *1 Input impedance	<ul style="list-style-type: none"> AC power supply type 					
	Sink input wiring			Source input wiring		
<ul style="list-style-type: none"> DC power supply type 						
Sink input wiring			Source input wiring			

*2. Do not connect with (0V) and (24V) terminals.

4.3.2 100V AC input type

→ For handling of 100V AC input, refer to Subsection 10.3.2.

Item	Specifications	
	FX3U-32MR/UA1	FX3U-64MR/UA1
Input points	16 points	32 points
Connection type	Removable terminal block (M3 screw)	
Input form	AC input	
Input signal voltage	100 to 120V AC +10%, -15% 50/60Hz	
Input impedance	Approx. 21kΩ/50Hz Approx. 18kΩ/60Hz	
Input signal current	4.7 mA/100V AC 50 Hz (70% or less when turned on simultaneously) 6.2 mA/110V AC 60 Hz (70% or less when turned on simultaneously)	
ON input sensitivity current	3.8 mA or more	
OFF input sensitivity current	1.7 mA or less	
Input response time	Approx. 25 to 30 ms (A high-speed receiving is improper)	
Input signal form	Contact input	
Input circuit insulation	Photo-coupler insulation	
Indication of input operation	LED on panel lights when input.	
Input circuit diagram *1 Input impedance		

1

Introduction

2

Features and
Part Names

3

Product
Introduction

4

Specifications

5

Version and
Peripheral
Devices

6

System
Configuration

7

Input/Output
Nos., Unit Nos.

8

Installation

9

Preparation and
Power Supply
Wiring

10

Input Wiring

4.4 Output Specifications

The main unit output specifications are explained below.

4.4.1 Relay output type

The output numbers in the table indicate the main unit terminal numbers. "Y010 or more" means the numbers from Y010 to the largest number that the main unit has.
(The output numbers of FX3U-16MR/ES are Y000 to Y007.)

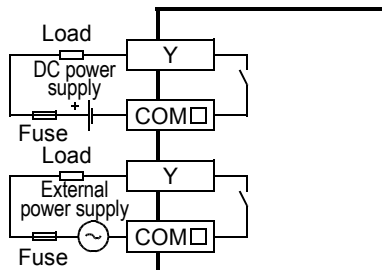
Item	Relay output specifications					
	FX3U-16MR/□S	FX3U-32MR/□S	FX3U-48MR/□S	FX3U-64MR/□S	FX3U-80MR/□S	FX3U-128MR/ES
Number of output points	8 points	16 points	24 points	32 points	40 points	64 points
Connecting type	Fixed terminal block (M3 screw)	Removable terminal block (M3 screw)				
Output type	Relay					
External power supply	30V DC or less or 240V AC or less (250V AC or less when the unit does not comply with CE, UL or cUL standards)					
Max. load	Resistance load	2 A / point The total load current of resistance loads per common terminal should be the following value. → For details on the common terminal for each model, refer to the terminal block layout. <ul style="list-style-type: none"> • 1 output point/common terminal: 2 A or less • 4 output points/common terminal: 8 A or less • 8 output points/common terminal: 8 A or less 				
	Inductive load	80 VA → For the product life, refer to Subsection 4.4.2. → For cautions on external wiring, refer to Subsection 12.2.4.				
Min. load	5V DC, 2 mA (reference value)					
Open circuit leakage current	-					
Response time	OFF→ON	Approx. 10 ms				
	ON→OFF	Approx. 10 ms				
Circuit insulation	Mechanical insulation					
Display of output operation	LED on panel lights when power is applied to relay coil.					
Output circuit configuration	 <p>A number (1 or more) is entered in □ of [COM □].</p>					

4.4.2 Product life of relay contacts

The product life of relay contacts varies considerably depending on the load type used. Take care that loads generating reverse electromotive force or rush current may cause poor contact or deposition of contacts which may lead to considerable reduction of the contact product life.

1. Inductive load

Inductive loads generate large reverse electromotive force between contacts at shutdown, which may cause arcing. At a fixed current consumption, as the power factor (phase between current and voltage) gets smaller, the arc energy gets larger.

The standard life of contacts used for Inductive loads, such as contactors and solenoid valves, is 500,000 operations at 20VA.

The following table shows the approximate life of a relay based on the results of an operation life test.

Test condition: 1 sec. ON / 1 sec.OFF

Load capacity		Contact life
20 VA	0.2 A / 100V AC	3,000,000 times
	0.1 A / 200V AC	
35 VA	0.35 A / 100V AC	1,000,000 times
	0.17 A / 200V AC	
80 VA	0.8 A / 100V AC	200,000 times
	0.4 A / 200V AC	

The product life of relay contacts becomes considerably shorter than the above conditions when the rush overcurrent is shut down.

→ **For precautions on using inductive loads, refer to Subsection 12.2.4 2.**

Some types of inductive loads generate rush current 5 to 15 times the stationary current at activation. Make sure that the rush current does not exceed the current corresponding to the maximum specified resistance load.

2. Lamp load

Lamp loads generally generate rush current 10 to 15 times the stationary current. Make sure that the rush current does not exceed the current corresponding to the maximum specified resistance load.

3. Capacitive load

Capacitive loads can generate rush current 20 to 40 times the stationary current. Make sure that the rush current does not exceed the current corresponding to the maximum specified resistance load. Capacitive loads such as capacitors may be present in electronic circuit loads including inverters.

→ **For the maximum specified resistance load, refer to Subsection 4.4.1.**

4.4.3 Transistor output (sink) type

The output numbers in the table indicate the main unit terminal numbers. "Y010 or more" means the numbers from Y010 to the largest number that the main unit has.

(The output numbers of FX3U-16MT/□S are Y000 to Y007.)

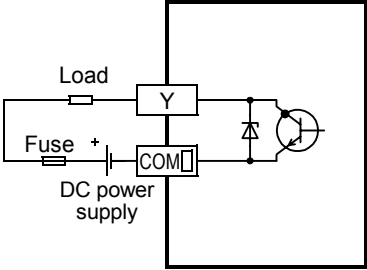
Item		Transistor output (sink) specifications					
		FX3U-16MT/□S	FX3U-32MT/□S	FX3U-48MT/□S	FX3U-64MT/□S	FX3U-80MT/□S	FX3U-128MT/ES
Number of output points		8 points	16 points	24 points	32 points	40 points	64 points
Connecting type		Fixed terminal block (M3 screw)	Removable terminal block (M3 screw)				
Output type/form		Transistor/sink output					
External power supply		5 to 30V DC					
Max. load	Resistance load	0.5 A / point The total load current of resistance loads per common terminal should be the following value. → For details on the common terminal for each model, refer to the terminal block layout. <ul style="list-style-type: none"> • 1 output point/common terminal: 0.5 A or less • 4 output points/common terminal: 0.8 A or less • 8 output points/common terminal: 1.6 A or less 					
	Inductive load	12W/24V DC The total of inductive loads per common terminal should be the following value. → For details on the common terminal for each model, refer to the terminal block layout. <ul style="list-style-type: none"> • 1 output point/common terminal: 12W or less/24V DC • 4 output points/common terminal: 19.2W or less/24V DC • 8 output points/common terminal: 38.4W or less/24V DC 					
Open circuit leakage current		0.1 mA or less/30V DC					
ON voltage		1.5 V or less					
Min. load		-					
Response time	OFF→ON	Y000 to Y002: 5 μs or less/10 mA or more (5 to 24V DC) Y003 or more: 0.2 ms or less/200 mA or more (at 24V DC)					
	ON→OFF	Y000 to Y002: 5 μs or less/10 mA or more (5 to 24V DC) Y003 or more: 0.2 ms or less/200 mA or more (at 24V DC)					
Circuit insulation		Photocoupler insulation					
Display of output operation		LED on panel lights when photocoupler is driven.					
Output circuit configuration		 <p>A common number applies to the □ of [COM □].</p>					

4.4.4 Transistor output (source) type

The output numbers in the table indicate the main unit terminal numbers. "Y010 or more" means the numbers from Y010 to the largest number that the main unit has.
(The output numbers of FX3U-16MT/□SS are Y000 to Y007.)

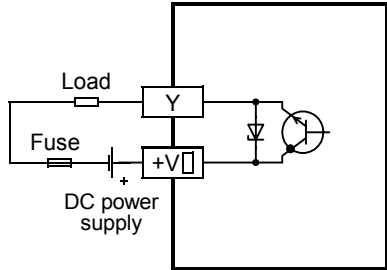
Item	Transistor output (source) specifications					
	FX3U-16MT/ □SS	FX3U-32MT/ □SS	FX3U-48MT/ □SS	FX3U-64MT/ □SS	FX3U-80MT/ □SS	FX3U-128MT/ ESS
Number of output points	8 points	16 points	24 points	32 points	40 points	64 points
Connecting type	Fixed terminal block (M3 screw)	Removable terminal block (M3 screw)				
Output type/form	Transistor/source output					
External power supply	5 to 30V DC					
Max. load	Resistance load	0.5 A / point The total load current of resistance loads per common terminal should be the following value. → For details on the common terminal for each model, refer to the terminal block layout. <ul style="list-style-type: none"> 1 output point/common terminal: 0.5 A or less 4 output points/common terminal: 0.8 A or less 8 output points/common terminal: 1.6 A or less 				
	Inductive load	12W/24V DC The total of inductive loads per common terminal should be the following value. → For details on the common terminal for each model, refer to the terminal block layout. <ul style="list-style-type: none"> 1 output point/common terminal: 12W or less/24V DC 4 output points/common terminal: 19.2W or less/24V DC 8 output points/common terminal: 38.4W or less/24V DC 				
Open circuit leakage current	0.1 mA or less/30V DC					
ON voltage	1.5 V or less					
Min. load	-					
Response time	OFF→ON	Y000 to Y002: 5 μs or less/10 mA or more (5 to 24V DC) Y003 or more: 0.2 ms or less/200 mA or more (at 24V DC)				
	ON→OFF	Y000 to Y002: 5 μs or less/10 mA or more (5 to 24V DC) Y003 or more: 0.2 ms or less/200 mA or more (at 24V DC)				
Circuit insulation	Photocoupler insulation					
Display of output operation	LED on panel lights when photocoupler is driven.					
Output circuit configuration	 <p>A common number applies to the □ of [+V □].</p>					

1	Introduction
2	Features and Part Names
3	Product Introduction
4	Specifications
5	Version and Peripheral Devices
6	System Configuration
7	Input/Output Nos., Unit Nos.
8	Installation
9	Preparation and Power Supply Wiring
10	Input Wiring

4.4.5 Triac output type

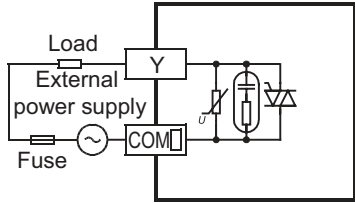
Item		Triac output specifications	
		FX3U-32MS/ES	FX3U-64MS/ES
Number of output points		16 points	32 points
Connecting type		Removable terminal block (M3 screw)	
Output type		Triac output (SSR)	
External power supply		85 to 242V AC	
Max. load	Resistance load	0.3 A / point The total load current of resistance loads per common terminal should be the following value. → For details on the common terminal for each model, refer to the terminal block layout.	
	Inductive load	15VA/100V AC, 30VA/200V AC	
Open circuit leakage current		1 mA/100V AC, 2 mA/200V AC	
Min. load		0.4VA/100V AC, 1.6VA/200V AC	
Response time	OFF→ON	1 ms or less	
	ON→OFF	10 ms or less	
Circuit insulation		Photo-thyristor insulation	
Display of output operation		LED on panel lights when photo-thyristor is driven.	
Output circuit configuration		 <p>A common number applies to the □ of [COM□].</p>	

4.5 Performance Specifications

The performance specifications are common to FX3U Series PLCs.

Item		Performance
Operation control system		Stored program repetitive operation system (dedicated LSI) with interruption function
Input/output control system		Batch processing system (when END instruction is executed) Input/output refresh instruction and pulse catch function are provided.
Programming language		Relay symbol system + step-ladder system (SFC notation possible)
Program memory	Max. memory capacity	64000-step (2k-, 4k-,8k-, 16k- or 32k-step memory can be selected by parameter settings.) Comments and file registers can be created in the program memory by parameter settings. • Comments: Up to 6350 points (50 points/500 steps) • File registers: Up to 7000 points (500 points/500 steps)
	Built-in memory capacity/type	64000-step (Symbolic information can be stored.*1)/ RAM (backed up by built-in lithium battery) • Battery life: Approx. 5 years (For details refer to Subsection 22.3.1)
	Memory cassette (Option)	Flash memory (The max. memory capacity varies depending on the model of the memory cassette.) • FX3U-FLROM-1M*2: 64000 steps (no loader function, symbolic information can be stored in the dedicated area (1300 kB).) • FX3U-FLROM-64L: 64000 steps (loader function, symbolic information can be stored.*1) • FX3U-FLROM-64: 64000 steps (no loader function, symbolic information can be stored.*1) • FX3U-FLROM-16: 16000 steps (no loader function, symbolic information can be stored.*1) Max. allowable write: 10,000 times
	Writing function during running	Provided (Program can be modified while the PLC is running.) → For the writing function during running, refer to Subsection 5.2.5.
	Password protection	Provided (with entry code function)
Real-time clock	Clock function	Built-in 1980 to 2079 (with correction for leap year) 2- or 4-digit year, accuracy within ±45 seconds/month at 25°C
Kinds of instructions	Basic instructions	Ver. 2.30 or later • Sequence instructions: 29 • Step-ladder instructions: 2 Former than Ver. 2.30 • Sequence instructions: 27 • Step-ladder instructions: 2
	Applied instructions	218 kinds, 497 instructions
Processing speed	Basic instructions	0.065 μs/instruction
	Applied instructions	0.642 μs to several hundred μs/instruction

*1. Storage of symbolic information is supported in Ver. 3.00 or later. The writable symbolic information capacity varies depending on the parameter setting contents and memory cassette type. Refer to Section 21.3 and the GX Works2 Version 1 Operating Manual (Common) for symbolic information capacity.

*2. Supported in Ver. 3.00 or later.

Item		Performance		
Number of input/output points	(1) Extension-combined number of input points	248 points	(3) total points	(1) + (2) ≤ (3) total number of points is 256 or less.
	(2) Extension-combined number of output points	248 points		
	(4) Remote I/O number of points (CC-Link)	224 points or less		Either the CC-Link or AS-i master can be used (the two cannot be used concurrently)
	(4) Remote I/O number of points (AS-i)	248 points or less		
	(3) + (4) total number of points	384 points or less		
Input/output relay	Input relay	X000 to X367	248 points	The device numbers are octal. The total number of input and output points is 256.
	Output relay	Y000 to Y367	248 points	
Auxiliary relay	For general [changeable]	M0 to M499	500 points	The retentive status can be changed by parameter settings.
	For keeping [changeable]	M500 to M1023	524 points	
	For keeping [fixed]	M1024 to M7679	6656 points	–
	For special	M8000 to M8511	512 points	–
State	Initial state (for general) [changeable]	S0 to S9	10 points	The retentive status can be changed by parameter settings.
	For general [changeable]	S10 to S499	490 points	
	For keeping [changeable]	S500 to S899	400 points	
	For annunciator (For keeping) [changeable]	S900 to S999	100 points	
	For keeping [fixed]	S1000 to S4095	3096 points	–
Timer (on-delay timer)	100 ms	T0 to T191	192 points	0.1 to 3,276.7 sec
	100 ms [for subroutine/interruption subroutine]	T192 to T199	8 points	0.1 to 3,276.7 sec
	10 ms	T200 to T245	46 points	0.01 to 327.67 sec
	1 ms accumulating type	T246 to T249	4 points	0.001 to 32.767 sec
	100 ms accumulating type	T250 to T255	6 points	0.1 to 3,276.7 sec
	1 ms	T256 to T511	256 points	0.001 to 32.767 sec
Counter	Increment for general (16 bits) [changeable]	C0 to C99	100 points	Counting from 0 to 32,767 The retentive status can be changed by parameter settings.
	Increment for keeping (16 bits) [changeable]	C100 to C199	100 points	
	Both directions for general (32 bits) [changeable]	C200 to C219	20 points	Counting from -2,147,483,648 to +2,147,483,647 The retentive status can be changed by parameter settings.
	Increment for keeping (32 bits) [changeable]	C220 to C234	15 points	

Item		Performance		
High-speed counter	1-phase 1-count input in both directions (32 bits) [changeable]	C235 to C245	Up to 8 points can be used in range from C235 to C255.	Counting from -2,147,483,648 to +2,147,483,647 [For keeping] The retentive status can be changed by parameter settings. → For the high-speed counter operating frequency, refer to the table shown in the next page.
	1-phase 2-count input in both directions (32 bits) [changeable]	C246 to C250		
	2-phase 2-count input in both directions (32 bits) [changeable]	C251 to C255		
Data register (32 bits when paired)	For general (16 bits) [changeable]	D0 to D199	200 points	The retentive status can be changed by parameter settings.
	For keeping (16 bits) [changeable]	D200 to D511	312 points	
	For keeping (16 bits) [fixed] <File register>	D512 to D7999 <D1000 to D7999>	7488 points <7000 points>	D1000 and later in 7488 points of fixed data register for keeping can be set as file register points in 500-point units by changing the parameter settings.
	For special (16 bits)	D8000 to D8511	512 points	-
	For index (16 bits)	V0 to V7 Z0 to Z7	16 points	-
Extension register (16 bits)		R0 to R32767	32768 points	Retained by battery during power failure
Extension file register (16 bits)		ER0 to ER32767	32768 points	Usable only when memory cassette is mounted
Pointer	For branching of JUMP and CALL	P0 to P4095	4096 points	For CJ instructions and CALL instructions
	Input interruption and input delay interruption	I0□□ to I5□□	6 points	-
	Timer interruption	I6□□ to I8□□	3 points	-
	Counter interruption	I010 to I060	6 points	For HSCS instructions
Nesting	For master control	N0 to N7	8 points	For MC instructions
Constant	Decimal number (K)	16 bits	-32,768 to +32,767	
		32 bits	-2,147,483,648 to +2,147,483,647	
	Hexadecimal number (H)	16 bits	0 to FFFF	
		32 bits	0 to FFFFFFFF	
	Real number (E)	32 bits	-1.0 x 2 ¹²⁸ to -1.0 x 2 ⁻¹²⁶ , 0, 1.0 x 2 ⁻¹²⁶ to 1.0 x 2 ¹²⁸ Decimal-point and exponential notations are possible.	
Character string (" ")	Character string	Up to 32 one-byte characters can be used for a constant in an instruction.		

Operating frequency of high-speed counter

For hardware and software counter device numbers, refer to the following section.

→ Refer to Section 11.5.

Kind of high-speed counter		Input terminals (X000 to X007) of main unit	High-speed input special adapter (FX3U-4HSX-ADP)
Hardware counter	1-phase	100 kHz x 6 points, 10 kHz x 2 points	200 kHz x 8 points
	2-phase	50 kHz (multiply by 1), 50 kHz (multiply by 4)	100 kHz (multiply by 1), 100 kHz (multiply by 4)
Software counter	1-phase	40 kHz	40 kHz
	2-phase	40 kHz (multiply by 1), 10 kHz (multiply by 4)	40 kHz (multiply by 1), 10 kHz (multiply by 4)

1	Introduction
2	Features and Part Names
3	Product Introduction
4	Specifications
5	Version and Peripheral Devices
6	System Configuration
7	Input/Output Nos., Unit Nos.
8	Installation
9	Preparation and Power Supply Wiring
10	Input Wiring

4.6 External Dimensions (Weight and Installation)

The external dimensions of the main unit are explained.

4.6.1 FX3U-16M□, FX3U-32M□

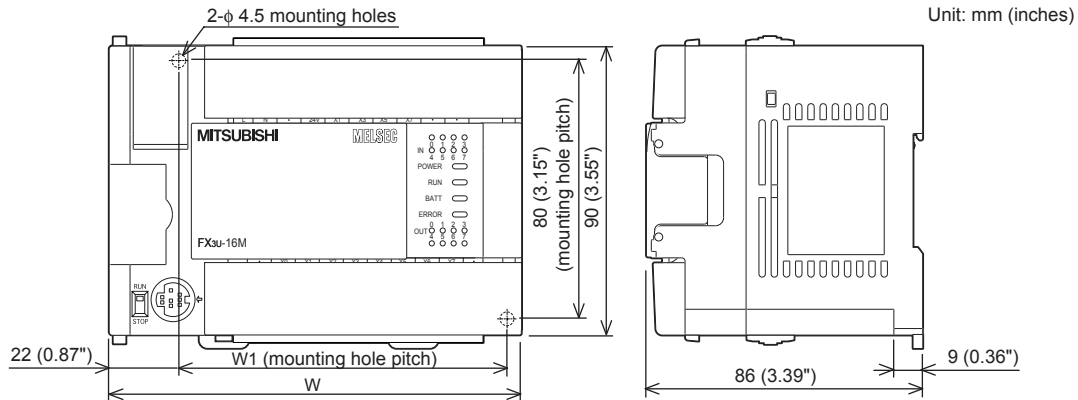

Series	Model name	W: mm (inches)	W1: mm (inches)	MASS (weight): kg (lbs)
FX3U-16M□	FX3U-16MR/ES	130 (5.12")	103 (4.06")	0.6 (1.32 lbs)
	FX3U-16MT/ES			
	FX3U-16MT/ESS			
	FX3U-16MR/DS			
	FX3U-16MT/DS			
	FX3U-16MT/DSS			
FX3U-32M□	FX3U-32MR/ES	150 (5.91")	123 (4.85")	0.65 (1.43 lbs)
	FX3U-32MT/ES			
	FX3U-32MT/ESS			
	FX3U-32MS/ES			
	FX3U-32MR/DS			
	FX3U-32MT/DS			
	FX3U-32MT/DSS			
	FX3U-32MR/UA1*1	182 (7.17")	155 (6.11")	0.85 (1.87 lbs)

*1. FX3U-32MR/UA1 uses 4-φ4.5 mounting holes.
The position of the mounting hole is equivalent to FX3U-48M□.

- 1) Accessories
 - Dust proof protection sheet
 - Manual supplied with product
- 2) Installation
 - 35 mm (1.38") wide DIN rail or Direct installation (with screws) (M4 x 2)

4.6.2 FX3U-48M□, FX3U-64M□, FX3U-80M□, FX3U-128M□

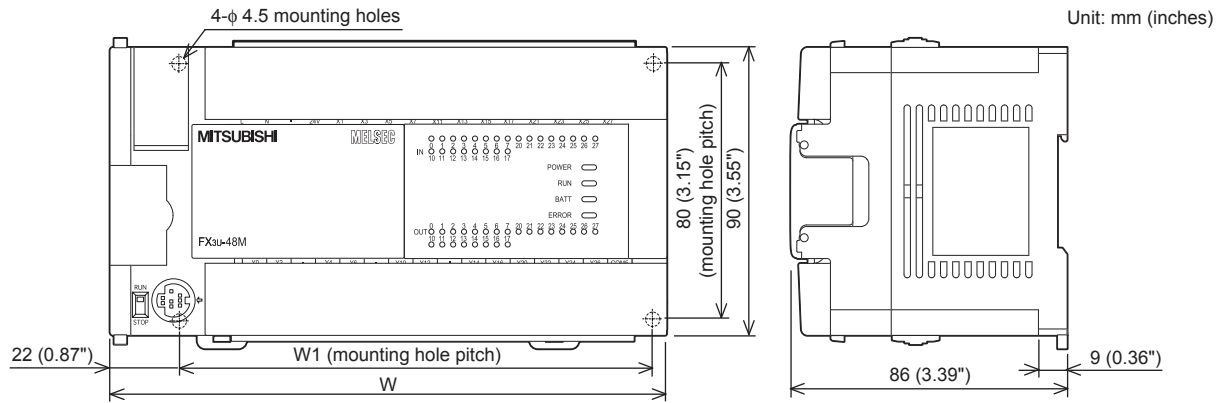

Series	Model name	W: mm (inches)	W1: mm (inches)	MASS (weight): kg (lbs)
FX3U-48M□	FX3U-48MR/ES	182 (7.17")	155 (6.11")	0.85 (1.87 lbs)
	FX3U-48MT/ES			
	FX3U-48MT/ESS			
	FX3U-48MR/DS			
	FX3U-48MT/DS			
	FX3U-48MT/DSS			
FX3U-64M□	FX3U-64MR/ES	220 (8.67")	193 (7.6")	1.00 (2.2 lbs)
	FX3U-64MT/ES			
	FX3U-64MT/ESS			
	FX3U-64MS/ES			
	FX3U-64MR/DS			
	FX3U-64MT/DS			
	FX3U-64MT/DSS			
FX3U-64MR/UA1	285 (11.23")	258 (10.16")	1.20 (2.64 lbs)	
FX3U-80M□	FX3U-80MR/ES	285 (11.23")	258 (10.16")	1.20 (2.64 lbs)
	FX3U-80MT/ES			
	FX3U-80MT/ESS			
	FX3U-80MR/DS			
	FX3U-80MT/DS			
	FX3U-80MT/DSS			
FX3U-128M□	FX3U-128MR/ES	350 (13.78")	323 (12.72")	1.80 (3.96 lbs)
	FX3U-128MT/ES			
	FX3U-128MT/ESS			

- 1) Accessories
 - Dust proof protection sheet
 - Manual supplied with product
- 2) Installation
 - 35 mm (1.38") wide DIN rail or Direct installation (with screws) (M4 x 4)

1	Introduction
2	Features and Part Names
3	Product Introduction
4	Specifications
5	Version and Peripheral Devices
6	System Configuration
7	Input/Output Nos., Unit Nos.
8	Installation
9	Preparation and Power Supply Wiring
10	Input Wiring

4.7 Terminal Layout

The terminal layout in the main unit is shown below.

4.7.1 Interpretation

Interpretation of terminal block layout

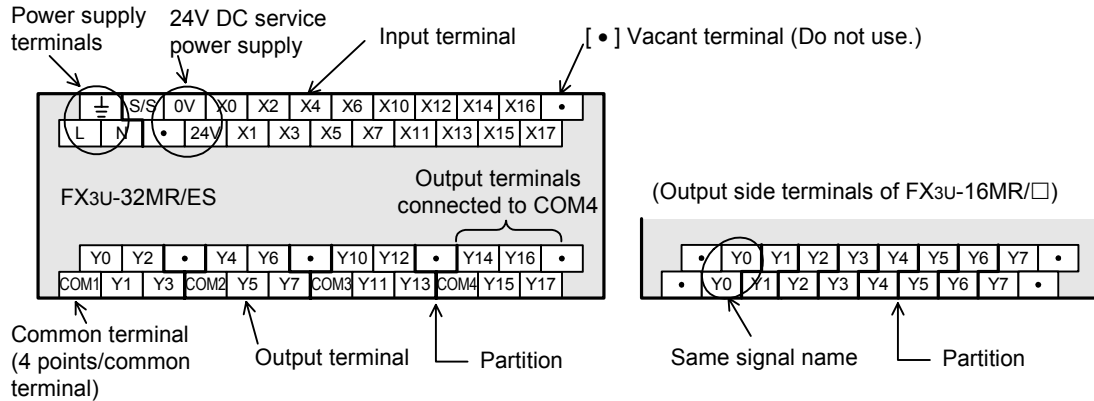

- Indication of Power supply terminals
The AC power type has [L] and [N] terminals, whereas the DC power type has [\oplus] and [\ominus] terminals.
For external wiring, make sure to read the power supply wiring described later.
→ Refer to Chapter 9.
- Indication of 24V DC service power supply
The AC power type has [0V] and [24V] terminals, whereas the DC power type shows [(0V)] and [(24V)] since the DC power type does not have the service power supply.
Do not connect with [(0V)] and [(24V)] terminals.
For external wiring, make sure to read the power supply wiring described later.
→ Refer to Chapter 9.
- Indication of Input terminal
Both AC and DC power type have the same input terminals, however, the external input wiring differs from each other.
For external wiring, make sure to read the input wiring described later.
→ Refer to Chapter 10.
- Indication of output terminals connected to common terminal (COM□)
One common terminal covers 1, 4 or 8 output points.
The output numbers (Y) connected to a common terminal are enclosed with heavy partition lines.
For transistor output (source) type, [COM□] is [+V□].
- Output terminals of FX3U-16MR/□ (top right figure)
One output point is connected to one common terminal.
Both ends of a relay output contact are wired, and the same signal name is shown on both sides.
For external wiring, make sure to read the output wiring described later.
→ Refer to Chapter 12.

4.7.2 FX3U-16M□

- AC power supply/DC input type

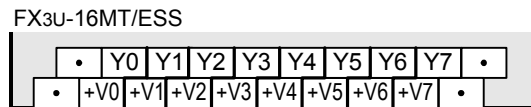
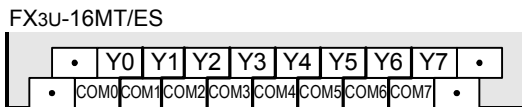
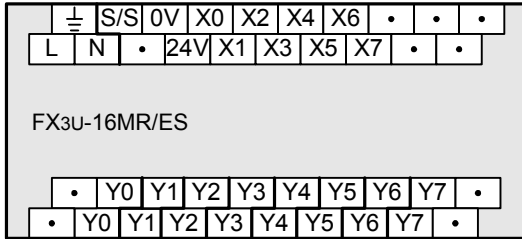

- DC power supply/DC input type

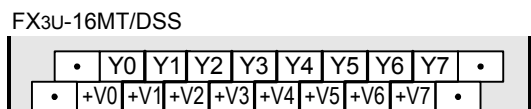
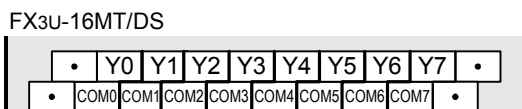
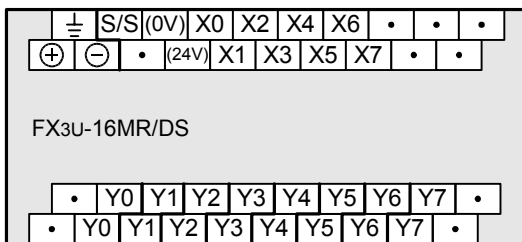

1	Introduction
2	Features and Part Names
3	Product Introduction
4	Specifications
5	Version and Peripheral Devices
6	System Configuration
7	Input/Output Nos., Unit Nos.
8	Installation
9	Preparation and Power Supply Wiring
10	Input Wiring

4.7.3 FX3U-32M□

- AC power supply/DC input type

\perp	S/S	0V	X0	X2	X4	X6	X10	X12	X14	X16	•
L	N	•	24V	X1	X3	X5	X7	X11	X13	X15	X17

FX3U-32MR/ES, FX3U-32MT/ES, FX3U-32MS/ES

Y0	Y2	•	Y4	Y6	•	Y10	Y12	•	Y14	Y16	•
COM1	Y1	Y3	COM2	Y5	Y7	COM3	Y11	Y13	COM4	Y15	Y17

FX3U-32MT/ESS

Y0	Y2	•	Y4	Y6	•	Y10	Y12	•	Y14	Y16	•
+V0	Y1	Y3	+V1	Y5	Y7	+V2	Y11	Y13	+V3	Y15	Y17

- DC power supply/DC input type

\perp	S/S	(0V)	X0	X2	X4	X6	X10	X12	X14	X16	•
⊕	⊖	•	(24V)	X1	X3	X5	X7	X11	X13	X15	X17

FX3U-32MR/DS, FX3U-32MT/DS

Y0	Y2	•	Y4	Y6	•	Y10	Y12	•	Y14	Y16	•
COM1	Y1	Y3	COM2	Y5	Y7	COM3	Y11	Y13	COM4	Y15	Y17

FX3U-32MT/DSS

Y0	Y2	•	Y4	Y6	•	Y10	Y12	•	Y14	Y16	•
+V0	Y1	Y3	+V1	Y5	Y7	+V2	Y11	Y13	+V3	Y15	Y17

- AC power supply/AC input type

\perp	•	COM	COM	X0	X2	X4	X6	•	•	X10	X12	X14	X16	•	•
L	N	•	•	X1	X3	X5	X7	•	•	X11	X13	X15	X17	•	•

FX3U-32MR/UA1

Y0	Y2	•	•	Y4	Y6	•	•	•	Y10	Y12	•	•	Y14	Y16	•
COM1	Y1	Y3	•	COM2	Y5	Y7	•	•	COM3	Y11	Y13	•	COM4	Y15	Y17

4.7.4 FX3U-48M□

- AC power supply/DC input type

\perp	S/S	0V	X0	X2	X4	X6	X10	X12	X14	X16	X20	X22	X24	X26	•
L	N	•	24V	X1	X3	X5	X7	X11	X13	X15	X17	X21	X23	X25	X27

FX3U-48MR/ES, FX3U-48MT/ES

Y0	Y2	•	Y4	Y6	•	Y10	Y12	•	Y14	Y16	Y20	Y22	Y24	Y26	COM5
COM1	Y1	Y3	COM2	Y5	Y7	COM3	Y11	Y13	COM4	Y15	Y17	Y21	Y23	Y25	Y27

FX3U-48MT/ESS

Y0	Y2	•	Y4	Y6	•	Y10	Y12	•	Y14	Y16	Y20	Y22	Y24	Y26	+V4
+V0	Y1	Y3	+V1	Y5	Y7	+V2	Y11	Y13	+V3	Y15	Y17	Y21	Y23	Y25	Y27

- DC power supply/DC input type

\perp	S/S	(0V)	X0	X2	X4	X6	X10	X12	X14	X16	X20	X22	X24	X26	•
⊕	⊖	•	(24V)	X1	X3	X5	X7	X11	X13	X15	X17	X21	X23	X25	X27

FX3U-48MR/DS, FX3U-48MT/DS

Y0	Y2	•	Y4	Y6	•	Y10	Y12	•	Y14	Y16	Y20	Y22	Y24	Y26	COM5
COM1	Y1	Y3	COM2	Y5	Y7	COM3	Y11	Y13	COM4	Y15	Y17	Y21	Y23	Y25	Y27

FX3U-48MT/DSS

Y0	Y2	•	Y4	Y6	•	Y10	Y12	•	Y14	Y16	Y20	Y22	Y24	Y26	+V4
+V0	Y1	Y3	+V1	Y5	Y7	+V2	Y11	Y13	+V3	Y15	Y17	Y21	Y23	Y25	Y27

1	Introduction
2	Features and Part Names
3	Product Introduction
4	Specifications
5	Version and Peripheral Devices
6	System Configuration
7	Input/Output Nos., Unit Nos.
8	Installation
9	Preparation and Power Supply Wiring
10	Input Wiring

4.7.5 FX3U-64M□

- AC power supply/DC input type

$\frac{\perp}{\perp}$	S/S	0V	0V	X0	X2	X4	X6	X10	X12	X14	X16	X20	X22	X24	X26	X30	X32	X34	X36	•
L	N	•	24V	24V	X1	X3	X5	X7	X11	X13	X15	X17	X21	X23	X25	X27	X31	X33	X35	X37

FX3U-64MR/ES, FX3U-64MT/ES, FX3U-64MS/ES

Y0	Y2	•	Y4	Y6	•	Y10	Y12	•	Y14	Y16	•	Y20	Y22	Y24	Y26	Y30	Y32	Y34	Y36	COM6
COM1	Y1	Y3	COM2	Y5	Y7	COM3	Y11	Y13	COM4	Y15	Y17	COM5	Y21	Y23	Y25	Y27	Y31	Y33	Y35	Y37

FX3U-64MT/ESS

Y0	Y2	•	Y4	Y6	•	Y10	Y12	•	Y14	Y16	•	Y20	Y22	Y24	Y26	Y30	Y32	Y34	Y36	+V5
+V0	Y1	Y3	+V1	Y5	Y7	+V2	Y11	Y13	+V3	Y15	Y17	+V4	Y21	Y23	Y25	Y27	Y31	Y33	Y35	Y37

- DC power supply/DC input type

$\frac{\perp}{\perp}$	S/S	(0V)	(0V)	X0	X2	X4	X6	X10	X12	X14	X16	X20	X22	X24	X26	X30	X32	X34	X36	•
⊕	⊖	•	(24V)	(24V)	X1	X3	X5	X7	X11	X13	X15	X17	X21	X23	X25	X27	X31	X33	X35	X37

FX3U-64MR/DS, FX3U-64MT/DS

Y0	Y2	•	Y4	Y6	•	Y10	Y12	•	Y14	Y16	•	Y20	Y22	Y24	Y26	Y30	Y32	Y34	Y36	COM6
COM1	Y1	Y3	COM2	Y5	Y7	COM3	Y11	Y13	COM4	Y15	Y17	COM5	Y21	Y23	Y25	Y27	Y31	Y33	Y35	Y37

FX3U-64MT/DSS

Y0	Y2	•	Y4	Y6	•	Y10	Y12	•	Y14	Y16	•	Y20	Y22	Y24	Y26	Y30	Y32	Y34	Y36	+V5
+V0	Y1	Y3	+V1	Y5	Y7	+V2	Y11	Y13	+V3	Y15	Y17	+V4	Y21	Y23	Y25	Y27	Y31	Y33	Y35	Y37

- AC power supply/AC input type

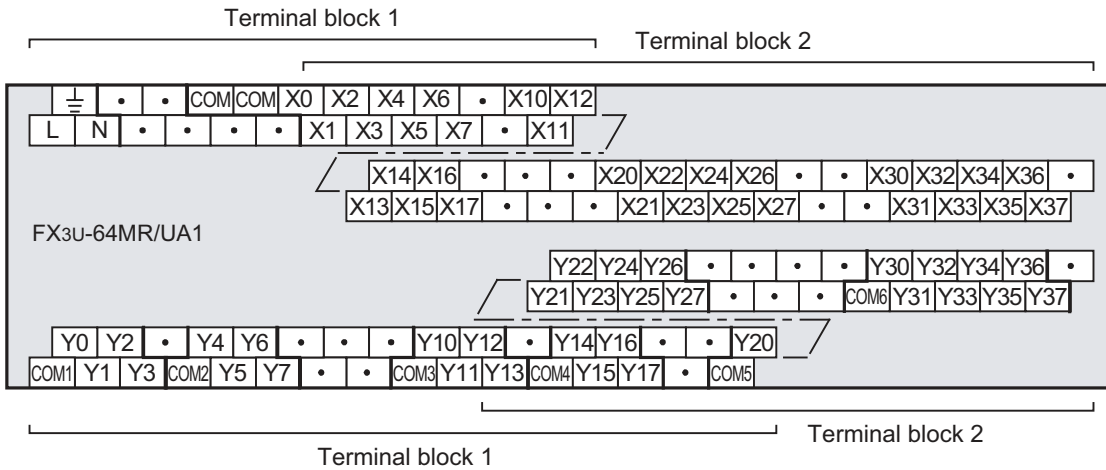

4.7.6 FX3U-80M□

- AC power supply/DC input type

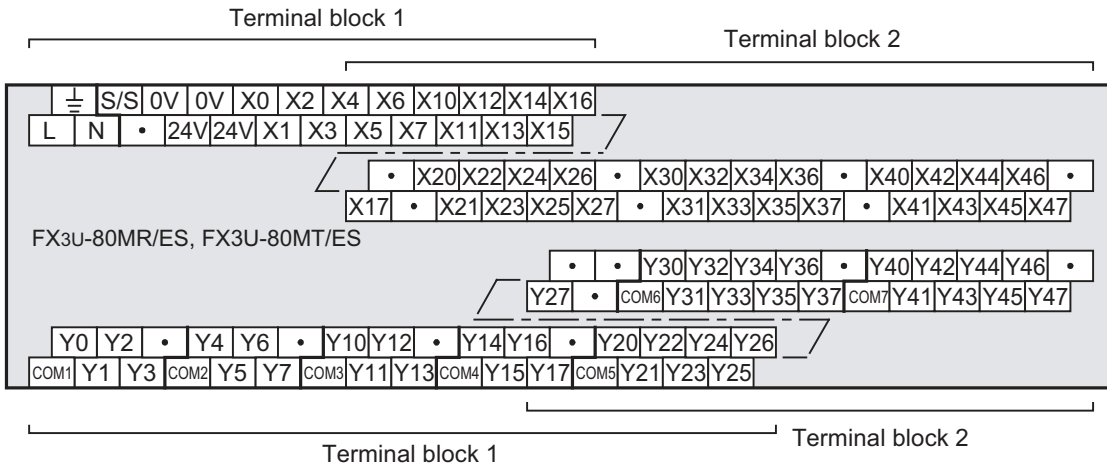

FX3U-80MT/ESS

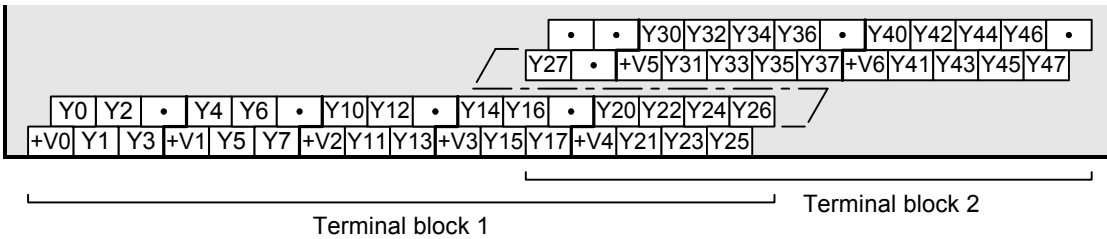

- DC power supply/DC input type

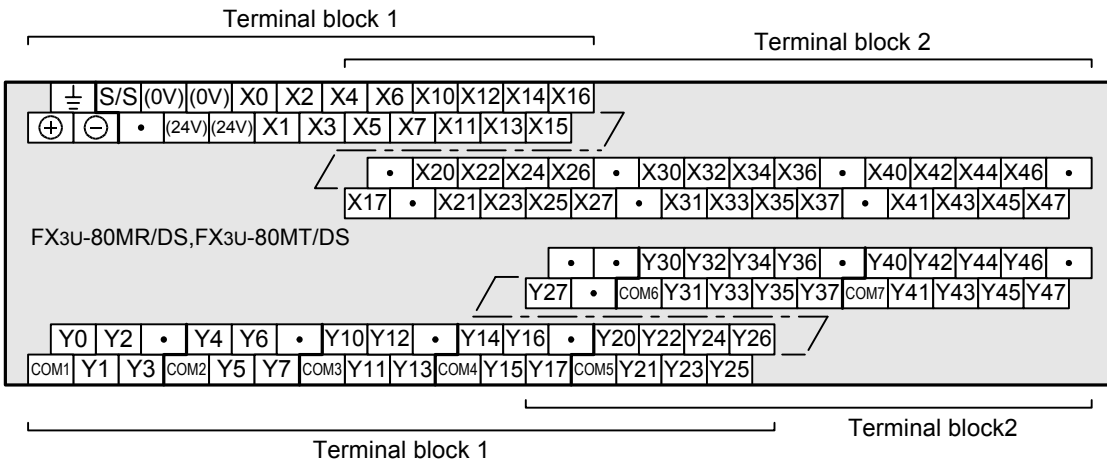

FX3U-80MT/DSS

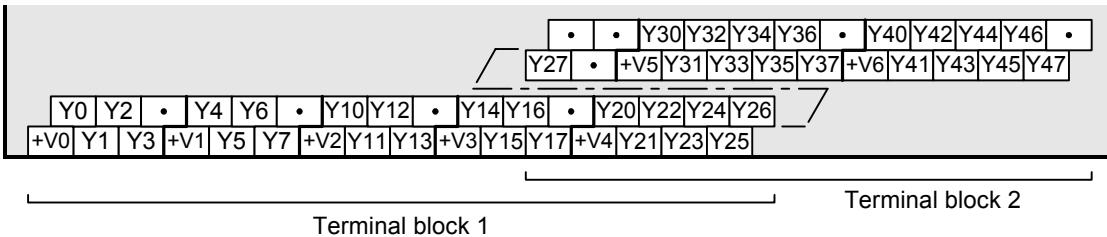

1	Introduction
2	Features and Part Names
3	Product Introduction
4	Specifications
5	Version and Peripheral Devices
6	System Configuration
7	Input/Output Nos., Unit Nos.
8	Installation
9	Preparation and Power Supply Wiring
10	Input Wiring

4.7.7 FX3U-128M□

- AC power supply/DC input type

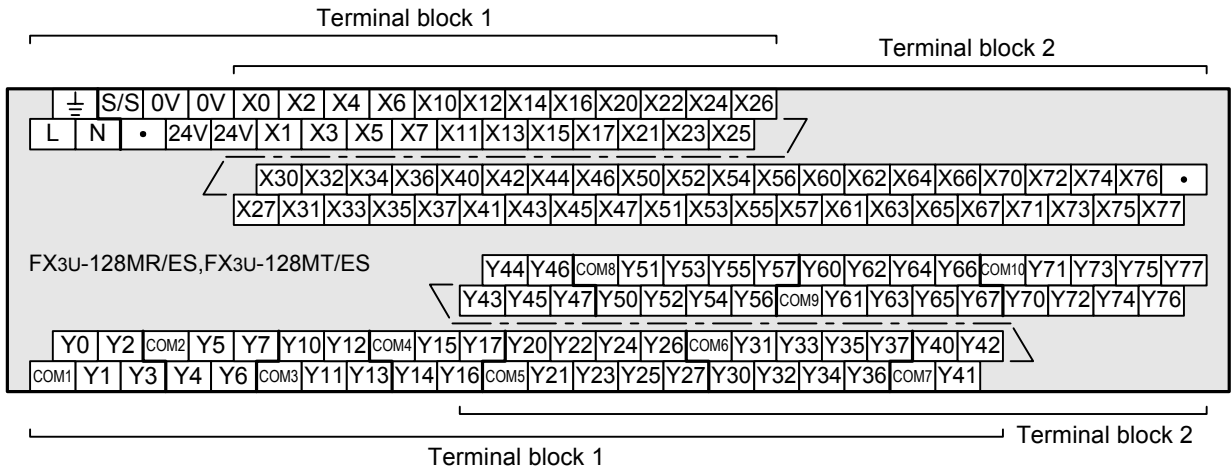

FX3U-128MT/ESS

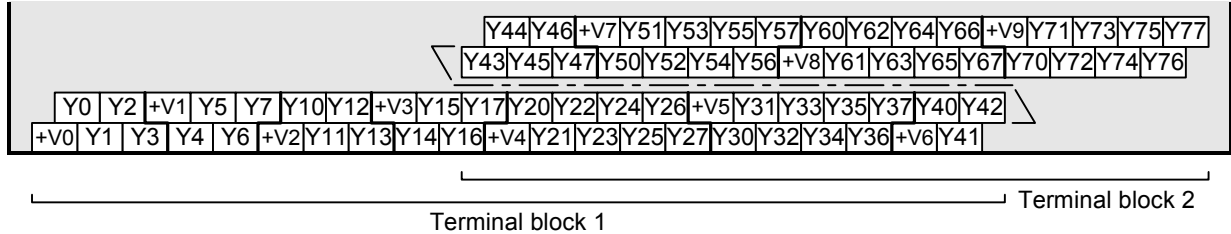

5. Version Information and Peripheral Equipment Connectivity

5.1 Version Upgrade History

5.1.1 How to look at manufacturer's serial number

The year and month of production of the product can be checked on the nameplate, and "LOT" indicated on the front of the product.

1. Checking the nameplate

The year and month of production of the product can be checked from the manufacturer's serial number "S/N" indicated on the label adhered to the right side of the product.

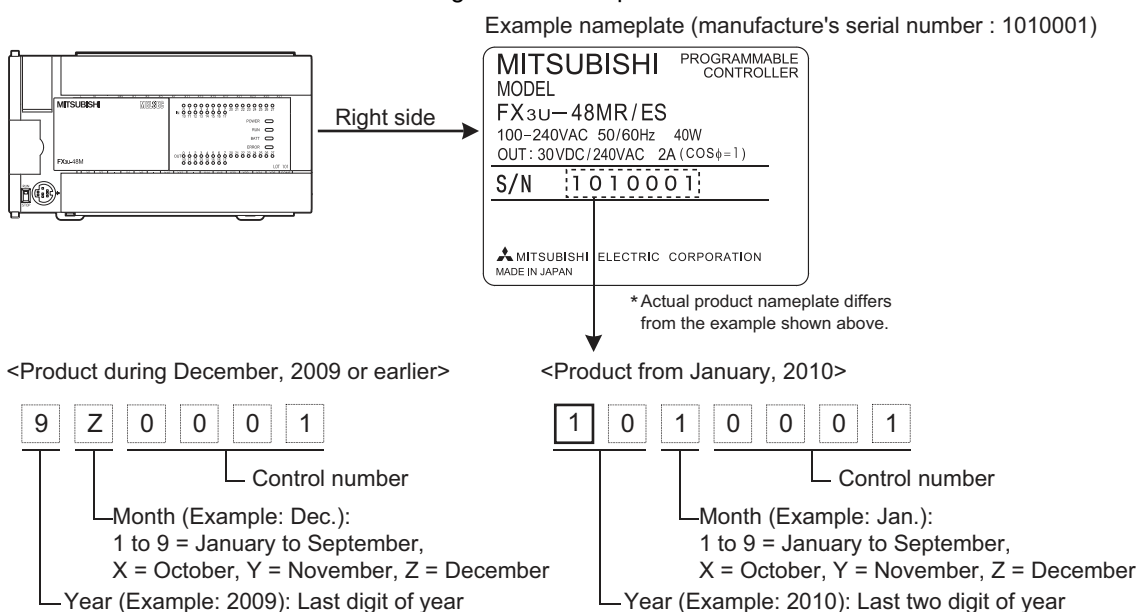

2. Checking the front of the product

The year and month of production of the product can be checked from the manufacturer's serial number "LOT" on the front (at the bottom) of the product.

* Products manufactured in and after January 2009 or later.

Example: FX3U-48MR/ES

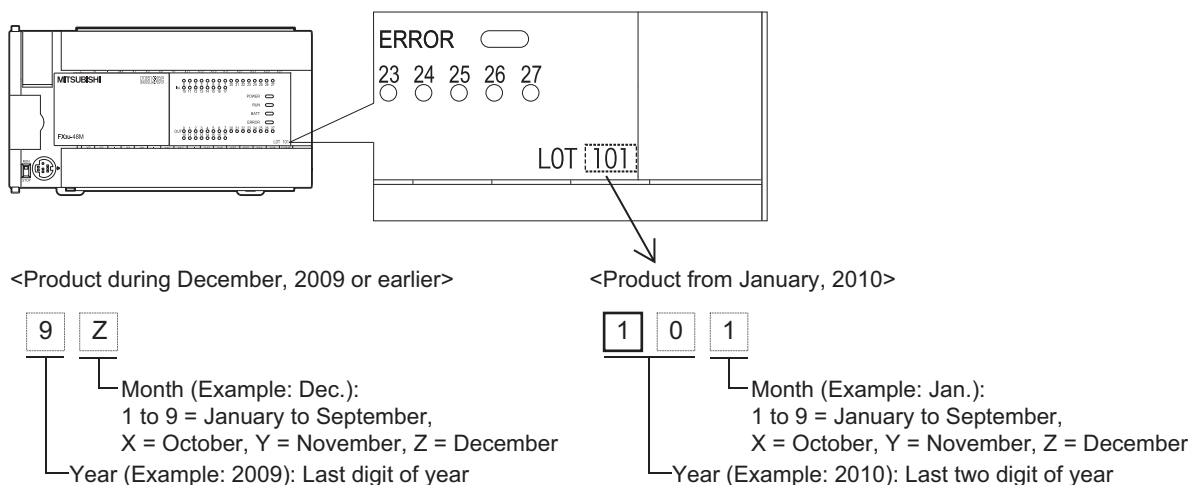

5.1.2 Version check method

In FX3U PLCs, users can obtain the PLC version information by monitoring special data register D8001 (decimal number), or the PLC version can be checked in "PLC Status" in the display module.

→ For the operating procedure of the display module, refer to Chapter 19.

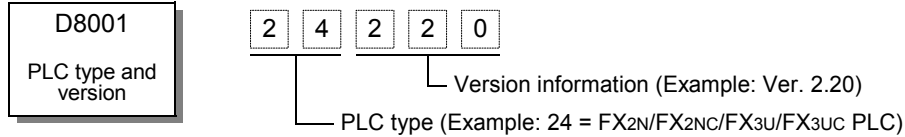

5.1.3 Version upgrade history

Version	Manufacturer's serial number	Contents of version upgrade
Ver. 2.20	55**** (May, 2005)	First product Corresponds to FX3UC PLC Ver. 2.20.
Ver. 2.30	5Y**** (November, 2005)	The following instructions are added or their functions are enhanced: MEP and MEF instructions are added. The functions of the MUL (FNC 22), DIV (FNC 23) and RS2 (FNC 87) instructions are enhanced.
Ver. 2.41	7Y**** (November, 2007)	The functions of the following instructions are enhanced: The baud rate "38400 bps" is supported in RS and RS2 instructions, inverter communication instructions and computer link.
Ver. 2.61	97**** (July, 2009)	<ul style="list-style-type: none"> Support of the following 6 instructions: FLCRT (FNC300), FLDEL (FNC301), FLWR (FNC302), FLRD (FNC303), FLCMD (FNC304), FLSTRD (FNC305) Supports customer keyword and permanent PLC lock. Supports connection of following special adapters: <ul style="list-style-type: none"> - FX3U-3A-ADP - FX3U-CF-ADP Supports the hardware error function of FX3U-4DA-ADP.
Ver. 2.70	107**** (July, 2010)	<ul style="list-style-type: none"> Support of the following 3 instructions: VRRD (FNC 85), VRSC (FNC 86), IVMC (FNC275) Supports connection of following analog volume expansion board: <ul style="list-style-type: none"> - FX3U-8AV-BD Supports the under-scale detection function of the FX3U-4AD-ADP and FX3U-3A-ADP.
Ver. 3.00	115**** (May, 2011)	<ul style="list-style-type: none"> Supports storage of symbolic information. Supports the setting "Read-protect the execution program." for block passwords. Special block error condition (D8166) is added. Supports connection of following memory cassette: <ul style="list-style-type: none"> - FX3U-FLROM-1M
Ver. 3.10	11Y**** (November, 2011)	<ul style="list-style-type: none"> Supports the following functions of the FX3U-16CCL-M: <ul style="list-style-type: none"> - Network parameter - Accessing the other station from CC-Link - Remote device station initialization procedure registration - CC-Link diagnostics Special parameter error (M8489 and D8489) is added.

5.2 Programming Tool Applicability

5.2.1 Applicable versions of programming tool

1. GX Works2

- GX Works2 Japanese version (SW□DNC-GXW2-J) is applicable to FX3u PLCs from the following versions.

FX3u PLC version	Model name (Media model name is shown below.)	Applicable GX Works2 version	Remarks
Before Ver. 2.70	GX Works2 SW□DNC-GXW2-J	Ver. 1.07H or later	• Model selection: FX3U/FX3UC
Before Ver. 3.00		Ver. 1.45X or later	
Before Ver. 3.10		Ver. 1.56J or later	
Ver. 3.10		Ver. 1.73B or later	

- GX Works2 English version (SW□DNC-GXW2-E) is applicable to FX3u PLCs from the following versions.

FX3u PLC version	Model name (Media model name is shown below.)	Applicable GX Works2 version	Remarks
Before Ver. 2.70	GX Works2 SW□DNC-GXW2-E	Ver. 1.08J or later	• Model selection: FX3U/FX3UC
Before Ver. 3.00		Ver. 1.48A or later	
Before Ver. 3.10		Ver. 1.62Q or later	
Ver. 3.10		Ver. 1.73B or later	

2. GX Developer

- GX Developer Japanese version (SW□D5C-GPPW-J) is applicable to FX3u PLCs from the following versions.

FX3u PLC version	Model name (Media model name is shown below.)	Applicable GX Developer version	Remarks
Before Ver. 2.30	GX Developer SW□D5C-GPPW-J	Ver. 8.23Z or later	• Model selection: FX3U(C) ^{*1}
Before Ver. 2.41		Ver. 8.29F or later	
Before Ver. 2.61		Ver. 8.29F or later ^{*2}	• Model selection: FX3U(C)
Ver. 2.61		Ver. 8.82L or later ^{*2}	

*1. For Ver. 8.23Z or 8.24A of GX Developer, the PLC type is FX3UC.

*2. Ver. 8.88S and later versions support the baud rate "38400 bps" in the communication setting for RS and RS2 instructions, inverter communication and computer link.

- GX Developer English version (SW□D5C-GPPW-E) is applicable to FX3u PLCs from the following versions.

FX3u PLC version	Model name (Media model name is shown below.)	Applicable GX Developer version	Remarks
Before Ver. 2.30	GX Developer SW□D5C-GPPW-E	Ver. 8.24A or later	• Model selection: FX3U(C) ^{*3}
Before Ver. 2.41		Ver. 8.29F or later	
Before Ver. 2.61		Ver. 8.29F or later ^{*4}	• Model selection: FX3U(C)
Ver. 2.61		Ver. 8.82L or later ^{*4}	

*3. For Ver. 8.24A of GX Developer, the PLC type is FX3UC.

*4. Ver. 8.89T and later versions support the baud rate "38400 bps" in the communication setting for RS and RS2 instructions, inverter communication and computer link.

3. FX-30P

FX-30P is applicable to FX3U PLCs from the following version.

FX3U PLC version	Model name	Applicable FX-30P version	Remarks
Before Ver. 2.41	FX-30P	Ver. 1.00 or later	Model selection: Not selected (Online mode)
Ver. 2.70		Ver. 1.20 or later	Model selection: FX3U(C) (Offline mode)

5.2.2 In case of programming tool (version) not applicable

Inapplicable programming tools can programme by setting alternative model.

1. Alternative model setting

Model to be programmed	Model to be set	Priority High → Low
FX3U PLC	FX3U(C) → FX3UC → FX2N → FX2	

2. Contents of restrictions

- Programming is enabled only in the function ranges such as instructions, device ranges and program sizes available in a PLC selected as the alternative model.
- When "FX3UC" is selected, programs and functions of applied instructions added from the corresponding version are different.
- Change the parameters such as the memory capacity and file register capacity using a programming tool allowing selection of "FX3U(C)" or "FX3UC".

5.2.3 Program transfer speed and programming tools

1. RS-422/RS-232C/USB communication

The FX3U PLC can write and read programs and perform monitoring at 115.2 kbps through RS-422/RS-232C/USB communication.

- 1) 115.2 kbps supported programming tools
GX Works2 (Ver. 1.08J or later), GX Developer (Ver. 8.18U or later), FX-30P (Ver. 1.00 or later)
- 2) 115.2 kbps supported interfaces
 - Standard built-in port or expansion board FX3U-422-BD for RS-422
When the RS-232C/RS-422 converter FX-232AWC-H or USB/RS-422 converter FX-USB-AW is connected.
 - Expansion board FX3U-232-BD for RS-232C
 - Special adapter FX3U-232ADP(-MB) for RS-232C
 - Expansion board FX3U-USB-BD for USB
- 3) In programming tools not supporting 115.2 kbps
Communication is executed at 9,600 or 19,200 bps.

5.2.4 Cautions on connecting peripheral equipment by way of expansion board or special adapter

When connecting peripheral equipment (programming tool or GOT [CPU direct connection]) by way of the FX3U-232-BD, FX3U-422-BD, FX3U-USB-BD or FX3U-232ADP(-MB), set the connection channel (CH1 or CH2) as follows. If the connection channel is not specified with the status below, communication error may occur in the connected peripheral equipment.

→ For details, refer to the Data Communication Edition.

- Set to "K0" the special data register for communication format setting of the channel connecting the peripheral equipment (CH1: D8400 or D8120, CH2: D8420).
- Set the communication parameter "PLC system [2]" of the channel connecting the peripheral equipment to "Not set" (as shown in the window below).

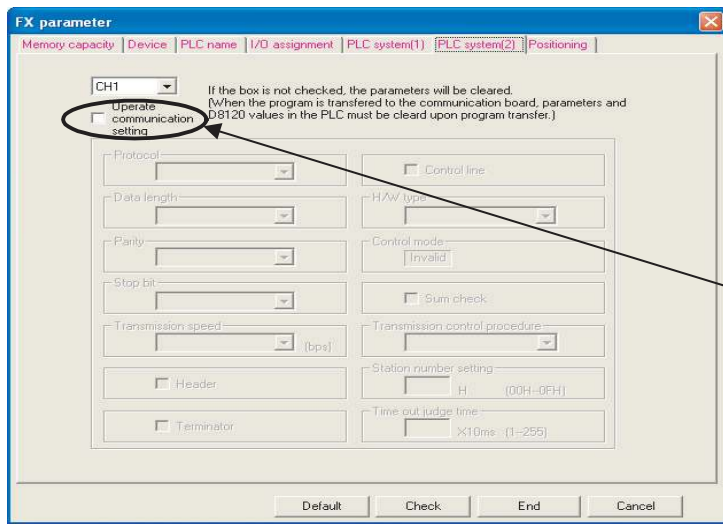

Leave this unchecked.

1	Introduction
2	Features and Part Names
3	Product Introduction
4	Specifications
5	Version and Peripheral Devices
6	System Configuration
7	Input/Output Nos., Unit Nos.
8	Installation
9	Preparation and Power Supply Wiring
10	Input Wiring

5.2.5 Cautions on write during RUN

In FX3U PLCs, write during RUN (program changes in the RUN mode) is enabled using the following programming tools.

→ For the operating procedure of and cautions on write during RUN, refer to the manual of the used programming tool.

Programming tools supporting write during RUN

- Japanese version

Programming tool	PLC	Version	Remarks
GX Works2*1 (SW□DNC-GXW2-J)	FX3U	Ver. 1.07H or later	Writing in the instruction and device ranges during RUN is supported in FX3U and FX3UC PLCs earlier than Ver. 2.70.
		Ver. 1.45X or later	Writing in the instruction and device ranges during RUN is supported in FX3U and FX3UC PLCs Ver. 2.70.
GX Developer*2 (SW□D5C-GPPW-J)	FX3U	Ver. 7.00A or later	Writing in the instruction and device ranges during RUN is supported in FX2N PLCs Ver. 3.00.
		Ver. 8.13P or later	Writing in the instruction and device ranges during RUN is supported in FX3UC PLCs earlier than Ver. 1.30.
		Ver. 8.18U or later	Writing in the instruction and device ranges during RUN is supported in FX3UC PLCs earlier than Ver. 2.20.
		Ver. 8.23Z or later	Writing in the instruction and device ranges during RUN is supported in FX3U and FX3UC PLCs earlier than Ver. 2.30.
		Ver. 8.29F or later	Writing in the instruction and device ranges during RUN is supported in FX3U and FX3UC PLCs earlier than Ver. 2.61.
		Ver. 8.82L or later	Writing in the instruction and device ranges during RUN is supported in FX3U and FX3UC PLCs Ver. 2.61.
FX-PCS/WIN*2	FX3U	Ver. 1.00 or later	Writing in the instruction and device ranges during RUN is supported in FX2 PLCs Ver. 3.30.
		Ver. 2.00 or later	Writing in the instruction and device ranges during RUN is supported in FX2N PLCs Ver. 1.00.
		Ver. 4.20 or later	Writing in the instruction and device ranges during RUN is supported in FX2N PLCs Ver. 3.00.

- English version

Programming tool	PLC	Version	Remarks
GX Works2*1 (SW□DNC-GXW2-E)	FX3U	Ver. 1.08J or later	Writing in the instruction and device ranges during RUN is supported in FX3U and FX3UC PLCs earlier than Ver. 2.70.
		Ver. 1.48A or later	Writing in the instruction and device ranges during RUN is supported in FX3U and FX3UC PLCs Ver. 2.70.
GX Developer*2 (SW□D5C-GPPW-E)	FX3U	Ver. 7.00A or later	Writing in the instruction and device ranges during RUN is supported in FX2N PLCs Ver. 3.00.
		Ver. 8.18U or later	Writing in the instruction and device ranges during RUN is supported in FX3UC PLCs earlier than Ver. 2.20.
		Ver. 8.24A or later	Writing in the instruction and device ranges during RUN is supported in FX3U and FX3UC PLCs earlier than Ver. 2.30.
		Ver. 8.29F or later	Writing in the instruction and device ranges during RUN is supported in FX3U and FX3UC PLCs earlier than Ver. 2.61.
		Ver. 8.82L or later	Writing in the instruction and device ranges during RUN is supported in FX3U and FX3UC PLCs Ver. 2.61.
FX-PCS/WIN-E*2	FX3U	Ver. 1.00 or later	Writing in the instruction and device ranges during RUN is supported in FX2N PLCs Ver. 1.00.
		Ver. 3.10 or later	Writing in the instruction and device ranges during RUN is supported in FX2N PLCs Ver. 3.00.

*1. Write during RUN is not possible with a SFC program.

*2. Write during RUN is not possible with a list program or a SFC program.

Cautions on write during RUN

Item	Caution	
Program memories which can be written in RUN mode	Built-in RAM and optional memory cassette (whose write protect switch is set to OFF)	
Number of program steps which can be written for circuit change in RUN mode	<ul style="list-style-type: none"> GX Works2 Ver. 1.08J or later GX Developer Ver. 8.24A or later 	256 steps or less after edition (addition/deletion) (including NOP immediately after circuit blocks except final circuit)
	<ul style="list-style-type: none"> GX Developer Ver. 8.22Y or former FX-PCS/WIN(-E) 	127 steps or less after edition (addition/deletion) (including NOP immediately after circuit blocks except final circuit)
Circuit blocks which cannot be written in RUN mode	Circuit blocks ^{*1} in which labels P and I are added, deleted or changed in edited circuits Circuit blocks in which 1-ms timers (T246 to T249 and T256 to T511) are added in edited circuits Circuit blocks in which the following instructions are included in edited circuits <ul style="list-style-type: none"> Instruction to output high-speed counters C235 to C255 (OUT instruction) SORT2 (FNC149), TBL (FNC152), RBFM (FNC278) and/or WBFM (FNC279) instructions 	

*1. Circuit blocks cannot be edited to insert a label as shown below when written during RUN.

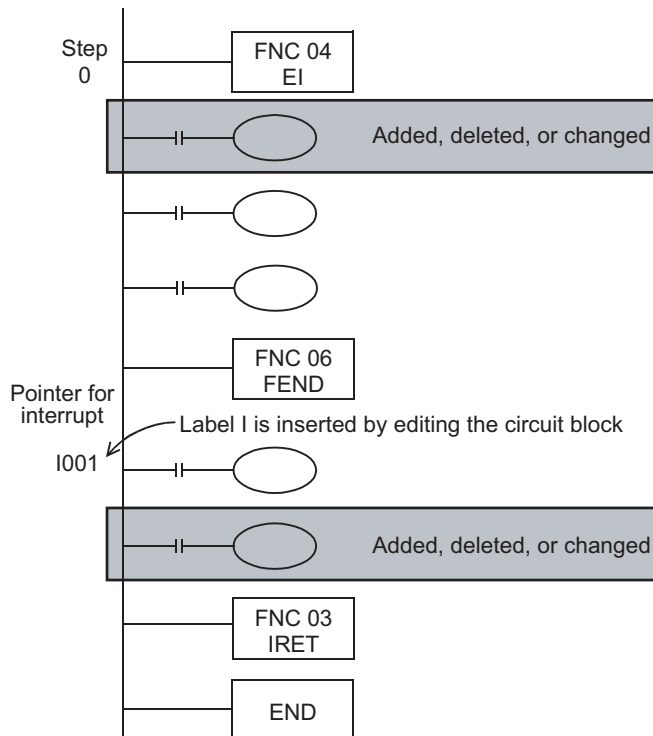

1	Introduction
2	Features and Part Names
3	Product Introduction
4	Specifications
5	Version and Peripheral Devices
6	System Configuration
7	Input/Output Nos., Unit Nos.
8	Installation
9	Preparation and Power Supply Wiring
10	Input Wiring

Item	Caution								
Circuit blocks which require attention on operation after write during RUN	<p>Avoid write during RUN to a circuit block including the following instructions during execution. If write during RUN is executed to such a circuit block, the PLC decelerates and stops pulse output.</p> <ul style="list-style-type: none"> • DSZR (FNC150), DVIT (FNC151), ZRN (FNC156), PLSV (FNC157) instructions [with acceleration/deceleration operation], DRVI (FNC158) and/or DRVA (FNC159) instructions 								
	<p>Avoid write during RUN to a circuit block including the following instruction during execution. If write during RUN is executed to such a circuit block, the PLC immediately stops pulse output.</p> <ul style="list-style-type: none"> • PLSV (FNC157) instruction [without acceleration/deceleration operation] 								
	<p>Avoid write during RUN to a circuit block including the following instructions during execution of communication. If write during RUN is executed to such a circuit block, the PLC may stop communication after that. If the PLC stops communication, set the PLC to the STOP mode once, and then set it to the RUN mode again.</p> <ul style="list-style-type: none"> • IVCK (FNC270), IVDR (FNC271), IVRD (FNC272), IVWR (FNC273), IVBWR (FNC274) and IVMC (FNC275) instructions 								
	<p>During RUN, avoid writing to a circuit block including the following instruction under execution. If such writing is executed during RUN, instructions being executed are canceled.</p> <ul style="list-style-type: none"> • FLCRT (FNC300), FLDEL (FNC301), FLWR (FNC302), FLRD (FNC303), FLCMD (FNC304) and FLSTRD (FNC305) instructions 								
	<p>When writing to a circuit block during RUN, which includes the following instructions, the following results.</p> <ul style="list-style-type: none"> • Instructions for falling edge pulse When write during RUN is completed for a circuit including an instruction for falling edge pulse (LDF, ANDF, or ORF instruction), the instruction for falling edge pulse is not executed without regard to the ON/OFF status of the target device. When write during RUN is completed for a circuit including an instruction for falling edge pulse (PLF instruction), the instruction for falling edge pulse is not executed without regard to the ON/OFF status of the device that is set as the operation condition. It is necessary to set to ON the target device or operation condition device once and then set it to OFF for executing the instruction for falling edge pulse. • Instructions for rising edge pulse When write during RUN is completed for a circuit including an instruction for rising edge pulse, the instruction for rising edge pulse is executed if a target device of the instruction for rising edge pulse or the operation condition device is ON. Target instructions for rising edge pulse: LDP, ANDP, ORP, and pulse operation type applied instructions (such as MOV_P) <table border="1" style="width: 100%; text-align: center;"> <thead> <tr> <th>Contact ON/OFF status (while write during RUN is executed)</th> <th>Instruction for rising edge pulse</th> <th>Instruction for falling edge pulse</th> </tr> </thead> <tbody> <tr> <td>OFF</td> <td>Not executed</td> <td>Not executed</td> </tr> <tr> <td>ON</td> <td>Executed*1</td> <td>Not executed</td> </tr> </tbody> </table> <p>*1. The PLS instruction is not executed.</p>	Contact ON/OFF status (while write during RUN is executed)	Instruction for rising edge pulse	Instruction for falling edge pulse	OFF	Not executed	Not executed	ON	Executed*1
Contact ON/OFF status (while write during RUN is executed)	Instruction for rising edge pulse	Instruction for falling edge pulse							
OFF	Not executed	Not executed							
ON	Executed*1	Not executed							

Item	Caution									
<p>Circuit blocks which require attention on operation after write during RUN</p>	<p>When writing to a circuit block during RUN, which includes the following instructions, the following results.</p> <ul style="list-style-type: none"> MEP instruction (Conversion of operation result to leading edge pulse instruction) When completing Write during RUN to a circuit including the MEP instruction, the execution result of the MEP instruction turns ON (conducting state) if the operation result up to the MEP instruction is ON. MEF instruction (Conversion of operation result to trailing edge pulse instruction) When completing Write during RUN to a circuit including the MEF instruction, the execution result of the MEF instruction turns OFF (nonconducting state) regardless of the operation result (ON or OFF) up to the MEF instruction. When the operation result up to the MEF instruction is set to ON once and then set to OFF, the execution result of the MEF instruction turns ON (conducting state). <table border="1" data-bbox="722 685 1457 813"> <thead> <tr> <th data-bbox="722 685 986 741">Operation result up to MEP/MEF instruction</th> <th data-bbox="986 685 1222 741">MEP instruction</th> <th data-bbox="1222 685 1457 741">MEF instruction</th> </tr> </thead> <tbody> <tr> <td data-bbox="722 741 986 775">OFF</td> <td data-bbox="986 741 1222 775">OFF (nonconducting)</td> <td data-bbox="1222 741 1457 775">OFF (nonconducting)</td> </tr> <tr> <td data-bbox="722 775 986 813">ON</td> <td data-bbox="986 775 1222 813">ON (conducting)</td> <td data-bbox="1222 775 1457 813">OFF (nonconducting)</td> </tr> </tbody> </table>	Operation result up to MEP/MEF instruction	MEP instruction	MEF instruction	OFF	OFF (nonconducting)	OFF (nonconducting)	ON	ON (conducting)	OFF (nonconducting)
Operation result up to MEP/MEF instruction	MEP instruction	MEF instruction								
OFF	OFF (nonconducting)	OFF (nonconducting)								
ON	ON (conducting)	OFF (nonconducting)								
<p>Others</p>	<ul style="list-style-type: none"> When writing during RUN with GX Works2 Ver. 1.08J or later, GX Developer Ver. 8.18U or later, the program is as follows. When the number of program steps is reduced by deletion of contacts, coils and applied instructions, the program capacity becomes smaller by as many as the reduced number of steps. FX3U Ver. 3.00 or later, GX Works2 Ver. 1.62Q or later. Writing during RUN is enabled only when the protection status (valid or invalid) by the setting "Read-protect the execution program." for the block password is same as the protection status of the PLC designated as the target of writing during RUN. 									

1	Introduction
2	Features and Part Names
3	Product Introduction
4	Specifications
5	Version and Peripheral Devices
6	System Configuration
7	Input/Output Nos., Unit Nos.
8	Installation
9	Preparation and Power Supply Wiring
10	Input Wiring

5.3 Cautions on using transparent function by way of USB in GOT1000 Series

When monitoring circuits, device registration, etc. or reading/writing programs in an FX3u PLC from GX Developer Ver. 8.22Y or later using the transparent function by way of USB in the GOT1000 Series, make sure to execute the following setting.

If the following setting is not provided, a communication error occurs.

	GX Developer Ver. 8.21X or former	GX Developer Ver. 8.22Y or later*1
When using transparent function by way of USB in GOT1000 Series	Not supported (not available)	Setting shown below is required.
When using transparent function by way of RS-232 in GOT1000 Series	Set "COM port" and "Transmission speed" on "PC side I/F Serial setting" dialog box.	Select "RS-232C" in setting shown below, and set "COM port" and "Transmission speed".
When directly connecting GX Developer to PLC		

*1. GX Developer Ver. 8.24A or later supports the FX3u Series.

Setting in GX Developer (Ver. 8.22Y or later)

- 1 Select [Online] → [Transfer setup...] to open the "Transfer setup" dialog box.
- 2 Double-click [Serial] in [PC side I/F] to open the "PC side I/F Serial setting" dialog box.
- 3 Select "USB (GOT Transparent mode)".

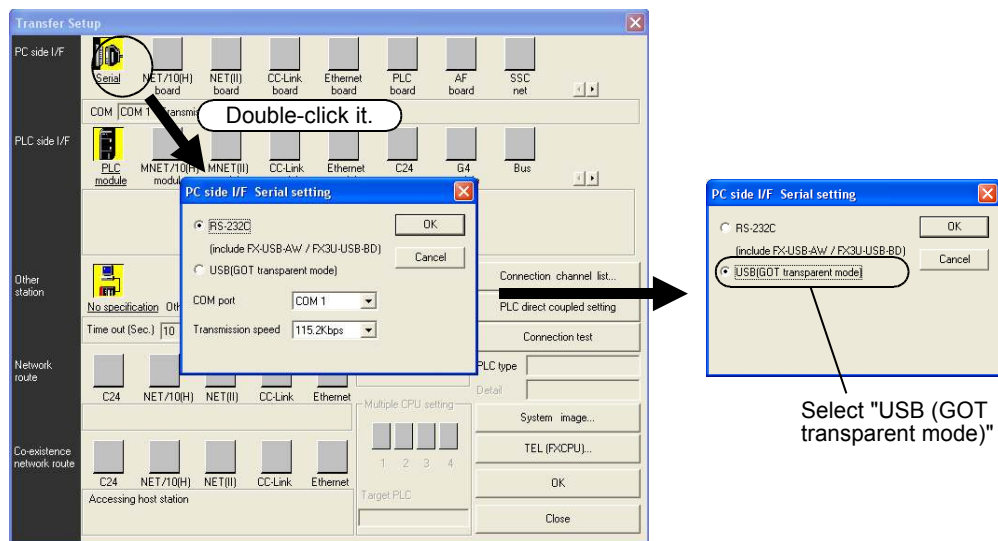

- 4 Click the [OK] button to finish the setting.

5.4 Cautions on using transparent port (2-port) function of GOT-F900 Series

When monitoring circuits, device registration, etc. in an FX3U PLC from GX Developer Ver. 8.18U or later using the transparent (2-port) function in the GOT-F900 Series, make sure to execute the following setting. If the following setting is not provided, write to PLC, read from PLC, verify with PLC, etc. operate normally, but monitoring (ladder monitor, entry datemonitor, etc.) cannot be normally executed.

	GX Developer Ver. 8.12N or earlier	GX Developer Ver. 8.18U or later	GX Developer Ver. 8.22Y or later
When directly connecting GX Developer to PLC	Set "COM port" and "Transmission speed" on "PC side I/F Serial setting" dialog box.		Select "RS-232C" on "PC side I/F Serial setting" dialog box, and set "COM port" and "Transmission speed."
When using transparent function in GOT-F900 Series	Setting shown below is required.	Setting shown below is not required.	Select "RS-232C" on "PC side I/F Serial setting" dialog box, and execute setting shown below.

Setting in GX Developer (Ver. 8.18U or later)

- 1 Select [Online] → [Transfer setup...] to open the "Transfer Setup" dialog box.
- 2 Double-click [PLC module] in [PLC side I/F] to open the [PLC side I/F Detailed setting of PLC module] dialog box.
- 3 Put a check mark to the check box [via GOT-F900 transparent mode] as shown below.

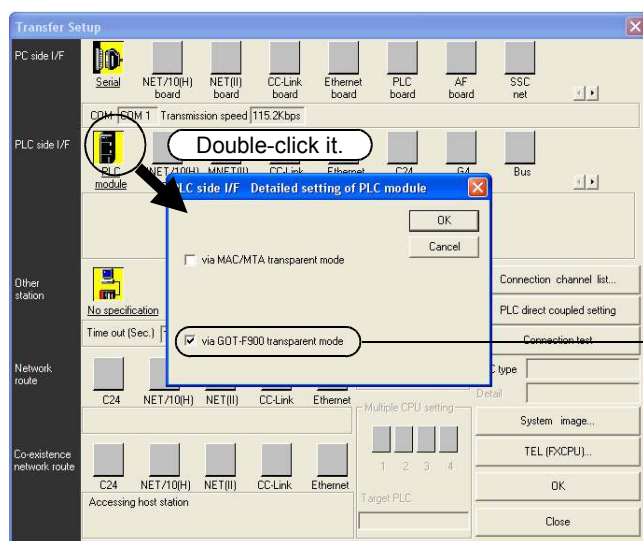

Put a check mark to the check box "via GOT-F900 transparent mode."

- 4 Click the [OK] button to finish the setting.

5.5 Other Peripheral Equipment Applicability

5.5.1 Other Peripheral Equipment Applicability

Model name	Applicability	Remarks
GOT1000 Series	Applicable (From first product)	The GOT1000 Series is applicable to the device ranges in the FX3U PLCs. Check the applicability of other items in the GOT manual.
F940WGOT	Applicable	For connection using the 2-port interface function*1, refer to Section 5.4. The following restriction applies when connected.
F940GOT F940 Handy GOT	Applicable	
F930GOT(-K)	Applicable	
F920GOT(-K)	Applicable	
ET-940	Applicable	Contents of restrictions Programming is enabled only in the function ranges such as instructions, device ranges and program sizes available in the FX2N and FX2NC PLCs. → For applicable models, refer to the GOT manual.
FX-10DM (-SET0)	Applicable	The following restriction applies when connected. Contents of restrictions Programming is enabled only in the function ranges such as instructions, device ranges and program sizes available in the FX2N and FX2NC PLCs. → For supported models and device ranges, refer to the FX-10DM USER'S MANUAL (Manual No. JY992D86401).
FX-10DU(-E)	Applicable	The following restriction applies when connected. Contents of restrictions It is limited to the device range and function range supported by the highest class model (FX2N or FX2) applicable in the product version. → For supported models and device ranges, refer to the FX-10DU-E/FX-20DU-E User's Manual (Manual No. JY992D54801).

*1. The F940GOT and ET-940 whose version is former than Ver. 1.10 do not support the transparent (2-port) function of the GX Developer.

6. Examination of System Configuration

6.1 Configuration of a Whole System

The configuration of a whole system is shown below as an example.

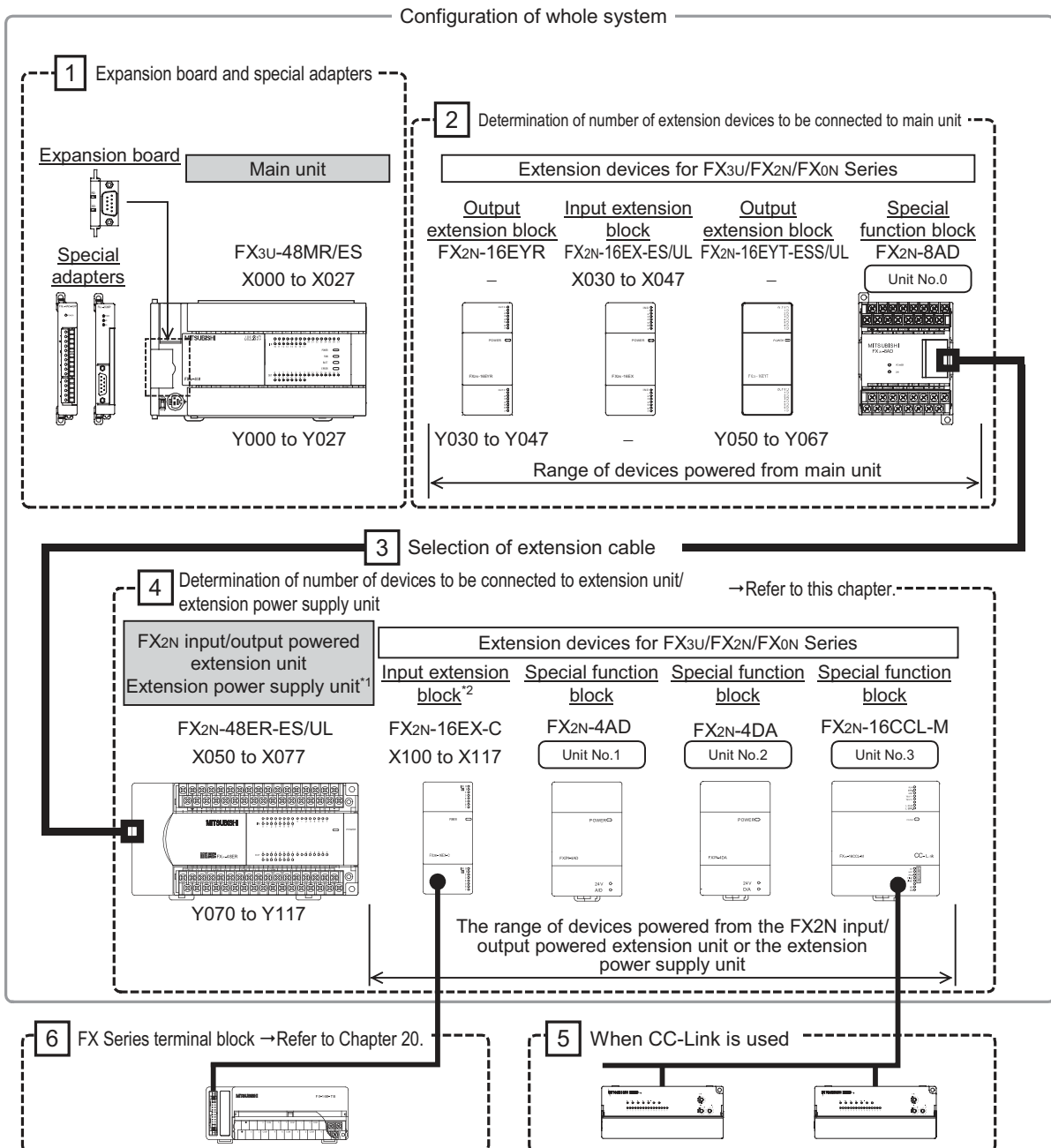

*1. Applicable when the main unit is AC power type.

*2. If an extension power supply unit is connected on the upstream side of an input extension block, the power must be supplied from the main unit's 24V DC service power to the input extension block.

Caution

When using an extension unit, select a power supply type that is the same as the main unit.

1	Introduction
2	Features and Part Names
3	Product Introduction
4	Specifications
5	Version and Peripheral Devices
6	System Configuration
7	Input/Output Nos., Unit Nos.
8	Installation
9	Preparation and Power Supply Wiring
10	Input Wiring

6.1.1 List of system components

Classification	Types (extracted) *1	Max. number of connect- able units	Other items to be considered				Reference	
			Max. number of input/ output points	Number of input/output (occupied) points	5V DC power supply	24V DC power supply		
A Main unit	FX3U-16MR/ES ⋮ FX3U-80MR/ES	1 unit	✓ 256 points or less	✓*6	–	–	Subsection 6.8.1	
D Input/output powered extension unit	FX2N-32ER FX2N-48ER	Not specified	✓ 256 points or less	✓*6	–	–	Subsection 6.8.4	
D Input/output extension block	FX2N-8EX FX2N-8EYR FX2N-16EX FX2N-16EYR	Not specified	✓ 256 points or less	✓*6	–	✓		
B Expansion board	FX3U-232-BD FX3U-422-BD FX3U-CNV-BD	1 unit	–	–	✓	–	Subsection 6.8.2	
C Special adapter	Analog	FX3U-4AD-ADP FX3U-4AD-TC-ADP	Up to 4 units	–	–	✓	✓*4	Subsection 6.8.3
	Communi- cation	FX3U-232ADP(-MB) FX3U-485ADP(-MB)	Up to 2 units*2	–	–	✓	–	
	CF card	FX3U-CF-ADP	1 unit*2	–	–	✓	✓*4	
	High- speed input	FX3U-4HSX-ADP	Up to 2 units	–	–	✓	✓	
	High- speed output	FX3U-2HSY-ADP	Up to 2 units	–	–	✓	✓	
E Special function unit/block	Analog	FX0N-3A FX2N-2AD FX2N-2DA	Up to 8 units*2	✓ 256 points or less	✓*7	✓	✓	Subsection 6.8.5
		FX2N-4AD FX2N-8AD FX2N-2LC		✓ 256 points or less				
	Communi- cation	FX2N-232IF		✓ 256 points or less	✓*7	✓	✓*4	
	Position- ing	FX2N-10PG FX2N-10GM FX2N-1RM-SET		✓ 256 points or less	✓*7	✓	✓*4	
	Network	FX2N-64CL-M		✓ 256 points or less	✓*7	–	✓*4	
		FX2N-16CCL-M		✓*3 384 points or less	✓*7	–	✓*4	
		FX2N-32ASI-M		✓		✓		
H Extension power supply unit	FX3U-1PSU-5V	Up to 2 units	–	–	–	–	Chapter 17	
Extension cable	FX0N-30EC FX0N-65EC FX2N-GM-65EC	One of them*5	–	–	✓	–	Subsection 6.4.3	

*1. For connectable product type, refer to the following chapter.
→ For details, refer to Chapter 3 "Introduction of Products (Compliant with Overseas Standards)".

- *2. For some products, there are restrictions on combination and number of connected units.
 - For details on the special adapters, refer to Subsection 6.4.1.
 - For details on the special function units/blocks, refer to Subsection 6.4.2.
- *3. When CC-Link master or AS-i master is used, the maximum number of input/output points is 384.
 - For an outline of CC-Link master, refer to Subsection 6.3.2 "Maximum number of input/output points when CC-Link master is used".
 - For an outline of AS-i master, refer to Subsection 6.3.3 "Maximum number of input/output points when AS-i master is used".
- *4. When the special function units/blocks and special adapters are externally wired to 24V DC power supply, the current consumed by them is added to the current consumption.
- *5. One extension cable can be used on a system. The cable to be used depends on the products to be added. The extension cable must be selected carefully.
 - For an outline of the extension cable, refer to Subsection 6.4.3 "Extension cable".
- *6. The number of input/output points varies depending on the type.
- *7. The special function units/blocks (except for the FX2N-16LNK-M) occupy eight input/output points each.
 - For details on the special function units/blocks, refer to Subsection 6.4.2.

1

Introduction

2

Features and
Part Names

3

Product
Introduction

4

Specifications

5

Version and
Peripheral
Devices

6

System
Configuration

7

Input/Output
Nos., Unit Nos.

8

Installation

9

Preparation and
Power Supply
Wiring

10

Input Wiring

6.1.2 System configuration with special adapters

1. When high-speed input/output special adapters are used

When only high-speed input/output special adapters are connected, the adapters can be used without an expansion board.

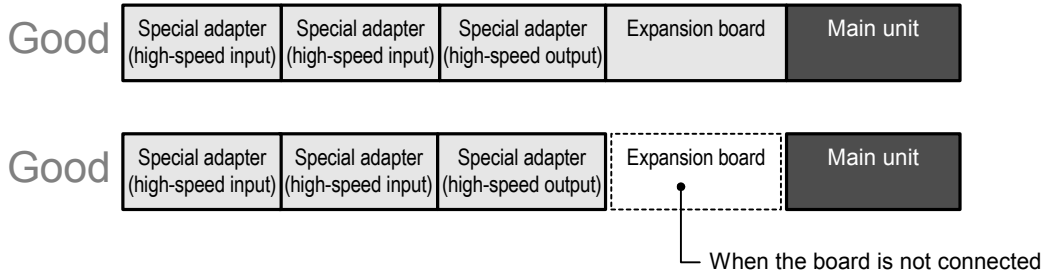

2. When analog, communication and CF card special adapters are used

1) Analog, communication and CF card special adapters must be used with an expansion board.

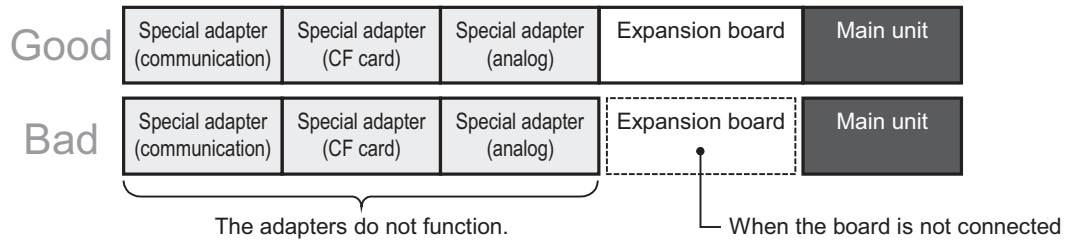

2) When an expansion board (other than the FX3U-CNV-BD) is used, one communication and CF card special adapter may be used.

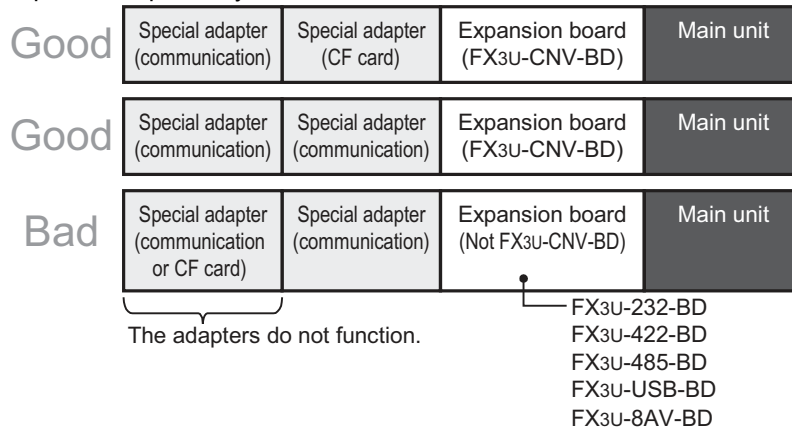

3. When high-speed input/output, analog, communication and CF card adapters are used

When these adapters are used, connect the high-speed input/output special adapters on the left side of the main unit.

The high-speed input/output special adapters cannot be connected on the downstream side of any communication, analog and CF card special adapter.

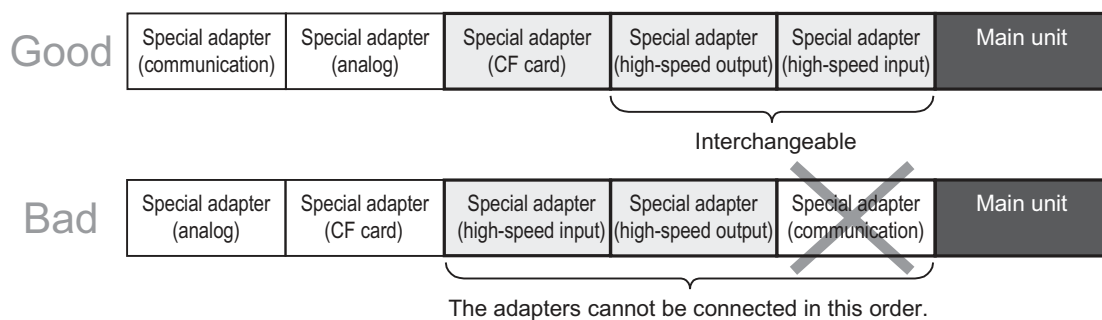

6.2 Rules of System Configuration

The system configuration must meet the following three requirements.

1 Number of input/output points

The total number of input/output points and remote I/O points on CC-Link or AS-i system must be 384 points or less on the whole system.

→ For details, refer to Section 6.3 "Number of Input/Output Points and Maximum Number of Input/Output Points".

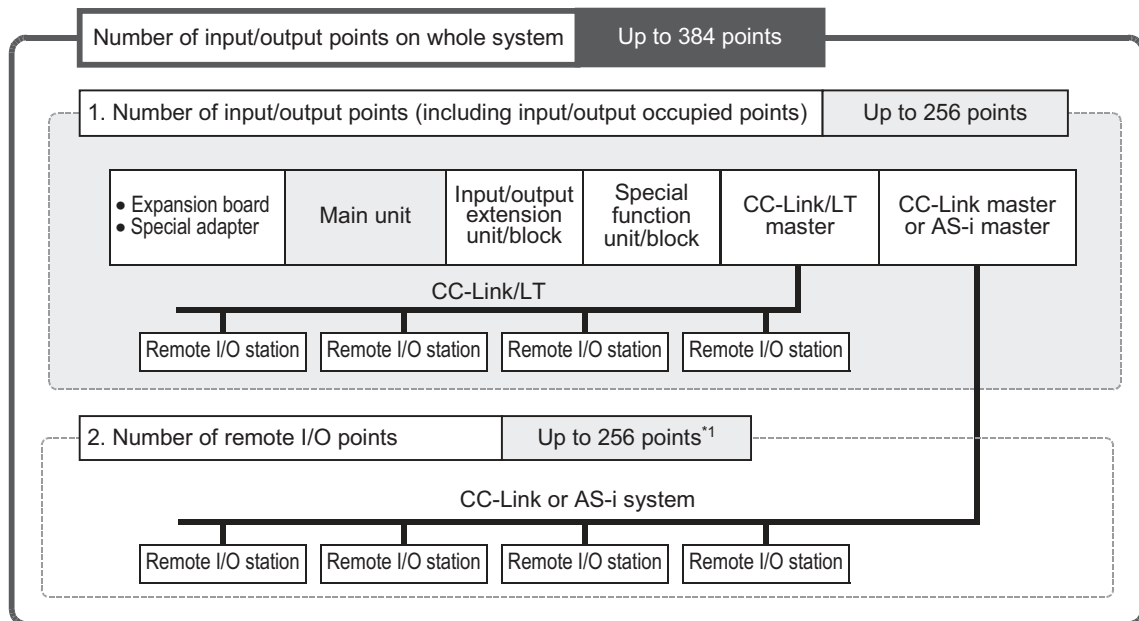

*1. The maximum number of remote input/output points varies depending on the network type. For details, refer to the following.

→ When CC-Link master is used, refer to Subsection 6.3.2.
→ When AS-i master is used, refer to Subsection 6.3.3.

2 Number of connected special extension devices

The numbers of connectable expansion boards, special adapters and special function units/blocks are shown below.

→ For details, refer to Section 6.4 "Number of Connected Special Extension Devices (Including Extension Cable)".

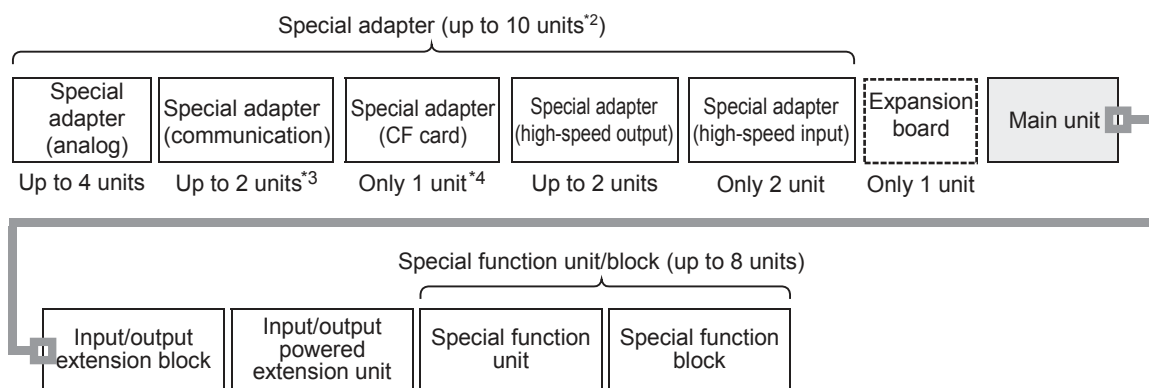

*2. When an expansion board other than FX3U-CNV-BD is used, up to 9 adapters can be connected.

*3. When an expansion board other than the FX3U-CNV-BD or a CF card special adapter is used, only 1 unit can be connected.

*4. When the total number of expansion boards used other than the FX3U-CNV-BD and/or communication special adapters is 2, no unit can be connected.

3 Calculation of current consumption

The power is supplied to each connected device from the built-in power supply of the main unit, the input/output powered extension unit or the extension power supply unit.

There are three types of built-in power supplies; 24V DC service power, 5V DC power and internal 24V DC power. The power to be consumed varies depending on the type of product to be added.

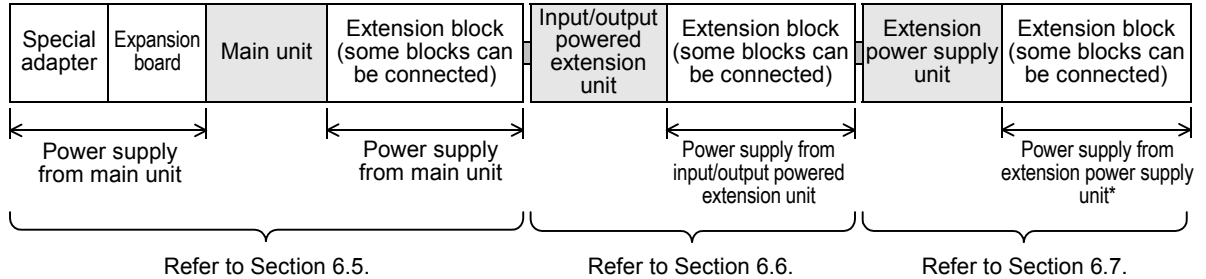

* When connecting an input extension block on the downstream side of an extension power supply unit, supply the power to the input extension block from the nearest main unit on the upstream side, or from an input/output powered extension unit on the upstream side of the extension power supply unit.

In the example above, the input/output powered extension unit supplies the power to extension blocks.

- For details, refer to Section 6.5 "Expansion of Main Unit (Calculation of Current Consumption)".
- For details, refer to Section 6.6 "Expansion of FX2N Series I/O Powered Extension Unit (Calculation of Current Consumption)".
- For details, refer to Section 6.7 "Expansion of Extension Power Supply Unit (FX3U-1PSU-5V)".

6.3 Number of Input/Output Points and Maximum Number of Input/Output Points

6.3.1 Calculation of number of input/output points

To obtain the total number of input/output points, count the input/output points of input/output powered extension units/blocks and the input/output occupied points of special function units/blocks. The number of remote I/O points on CC-Link or AS-i master network must be excluded.

1 Total the number of input/output points on the main unit and the number of those on the input/output powered extension units/blocks.

To obtain the total number of input/output points, count the input points (X000 and more) and output points (Y000 and more) of the main unit and input/output powered extension units/blocks. The number of input/output points of each type of device is shown on the list below.

→ The list of numbers of input/output points is shown in Section 6.8.

2 Count the input/output points of the remote I/O stations connected on FX2N-64CL-M or FX2N-16LNK-M network.

Add the number of remote I/O points to the number of input/output points from the main unit and input/output powered extension units/blocks calculated in the above step.

→ For the method of calculating the number of remote I/O points, refer to the manual of each master.

3 Count the number of input/output occupied points of special function units/blocks.

The number of occupied input/output points per unit is 8.

The number of occupied input/output points of each type of device can be obtained by the following formula or from the list shown below.

→ For a list of occupied input/output points, refer to Section 6.8.

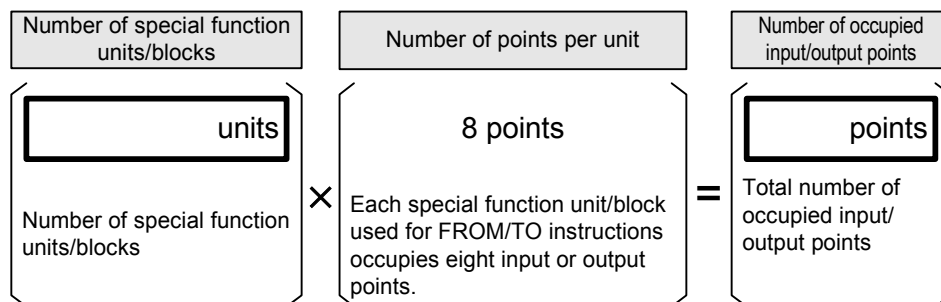

Observe the following instructions when using the following products.

- FX2N-1RM(-SET)
Up to 3 units can be sequentially connected to the end of one system. However, when three units are connected, they are counted as one unit, and the number of input/output occupied points is 8.
- FX3U-16CCL-M (CC-Link master)
Only one FX3U-16CCL-M unit can be connected to a single PLC main unit. This master cannot be used together with FX2N-16CCL-M and/or FX2N-32ASI-M.
- FX2N-16CCL-M (CC-Link master)
When more than one master station is connected, a remote I/O station cannot be connected to the 2nd and following master stations. This master cannot be used together with FX3U-16CCL-M and/or FX2N-32ASI-M.

1	Introduction
2	Features and Part Names
3	Product Introduction
4	Specifications
5	Version and Peripheral Devices
6	System Configuration
7	Input/Output Nos., Unit Nos.
8	Installation
9	Preparation and Power Supply Wiring
10	Input Wiring

- FX2N-32ASI-M (AS-i master)
Only one FX2N-32ASI-M unit can be connected to a single PLC main unit.
This master cannot be used together with FX3U-16CCL-M and/or FX2N-16CCL-M.
- FX3U-64CCL
Only one FX3U-64CCL unit can be connected to a single PLC main unit.

4 Calculate the total number of input/output points.

Total the number of points counted in Steps 1, 2 and 3, and check that it does not exceed 256 points (maximum number of input/output points).

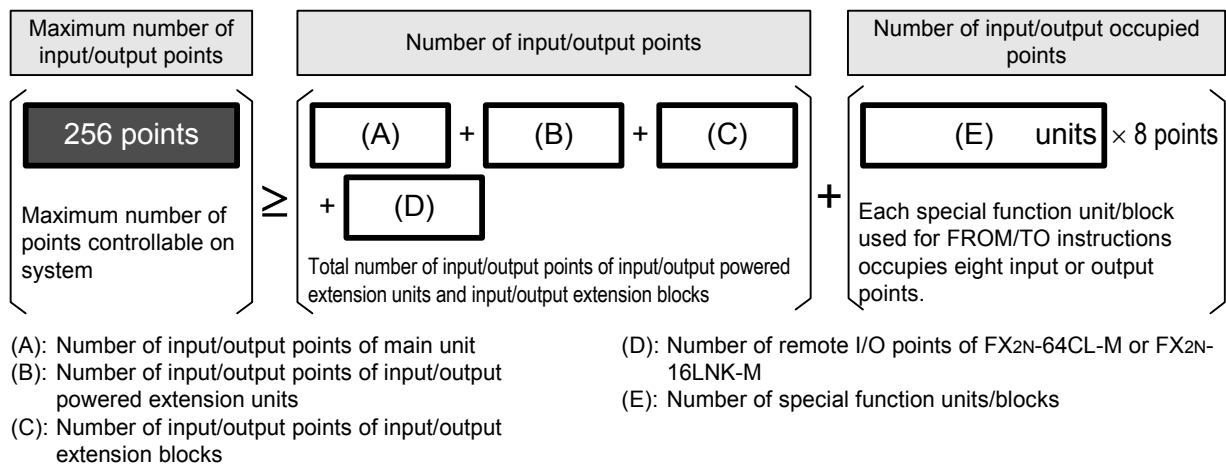

5 When CC-Link or AS-i master is used, count the remote I/O points.

When CC-Link or AS-i master is used, the total number of input/output points of the remote I/O stations connected on the network and the number of input/output points calculated in the previous step are 384 or less.

For details, refer to the following subsection.

1. FX3U-16CCL-M, FX2N-16CCL-M (CC-Link master)

Calculate the number of remote I/O points connected on the network in the following step.

→ When CC-Link master is used, refer to Subsection 6.3.2.

2. FX2N-32ASI-M (AS-i master)

Calculate the number of remote I/O points connected on the network in the following step.

→ When AS-i master is used, refer to Subsection 6.3.3.

6.3.2 Maximum number of input/output points when CC-Link master is used

1. Calculation of maximum number of input/output points

When CC-Link master block is used, the following maximum number of input/output points can be connected.

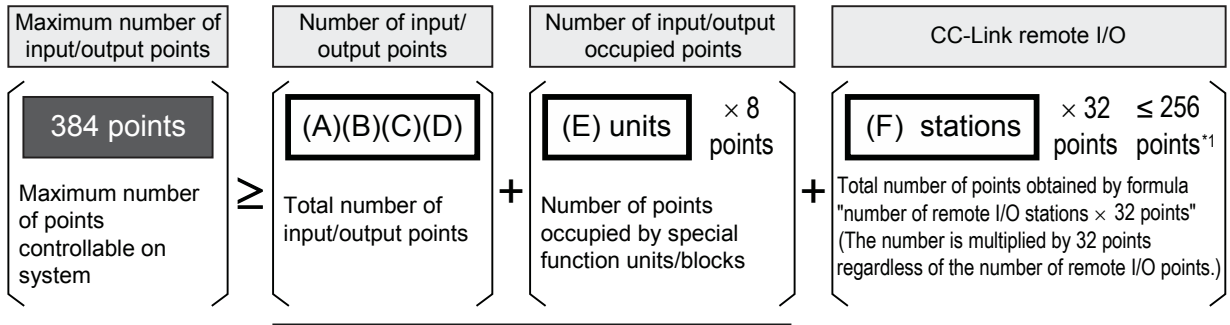

For details, refer to Subsection 6.3.1.

- (A): Number of input/output points of main unit
- (B): Number of input/output points of input/output powered extension units
- (C): Number of input/output points of input/output extension blocks
- (D): Number of remote I/O points of FX2N-64CL-M or FX2N-16LNK-M
- (E): Number of input/output points occupied by special function units/blocks
- (F): Number of remote I/O stations (units) connected to CC-Link master

*1. 224 points when the FX2N-16CCL-M is used.
The number of CC-Link points is calculated by the formula "32 points × number of stations" even when remote I/O stations having less than 32 points are used.
For details, refer to the manual of the CC-Link master block used.

2. Procedures for calculating number of input/output points based on example of system configuration

For the main unit, input/output powered extension units/blocks and CC-Link remote I/O stations, the number of input/output points and the total number of points are restricted.

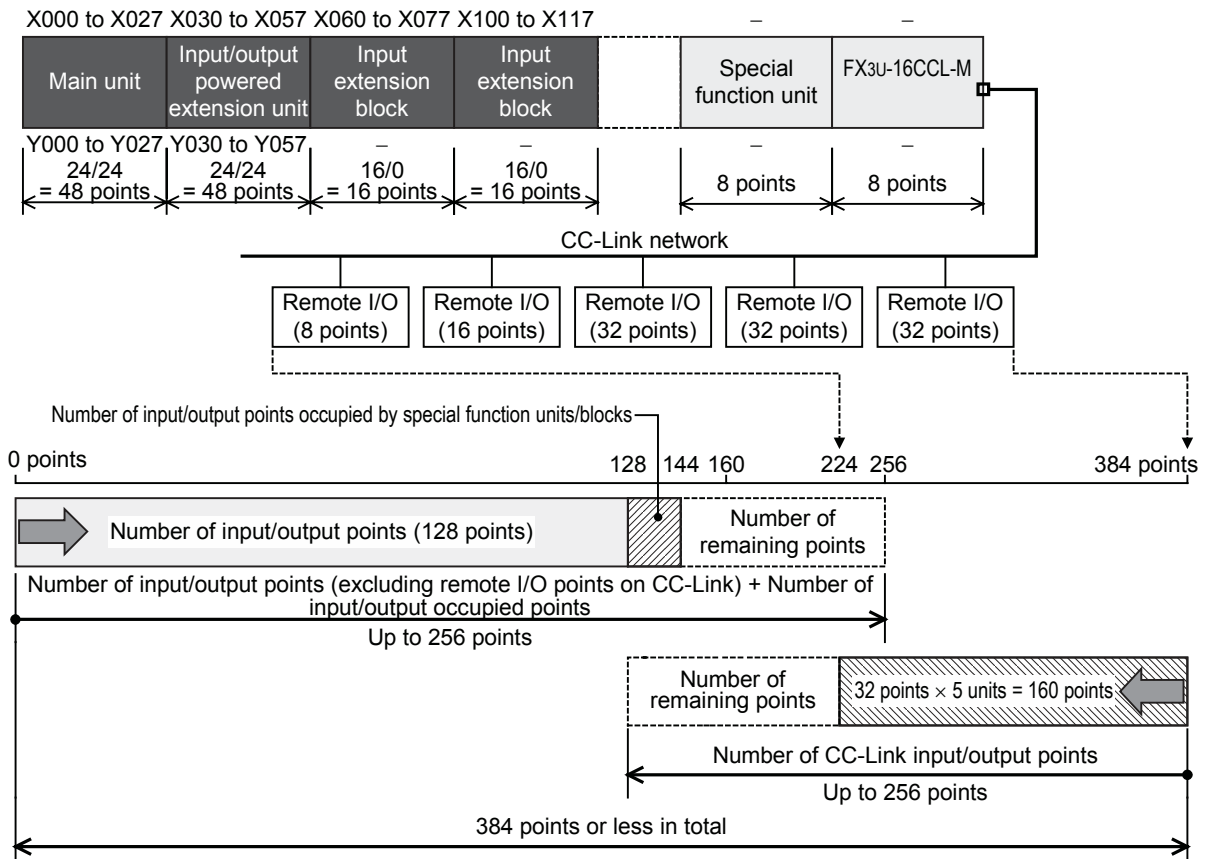

- 1 Introduction
- 2 Features and Part Names
- 3 Product Introduction
- 4 Specifications
- 5 Version and Peripheral Devices
- 6 System Configuration
- 7 Input/Output Nos., Unit Nos.
- 8 Installation
- 9 Preparation and Power Supply Wiring
- 10 Input Wiring

6.3.3 Maximum number of input/output points when AS-i master is used

1. Calculation of maximum number of input/output points

When AS-i system master block is used, the following maximum number of input/output points can be connected.

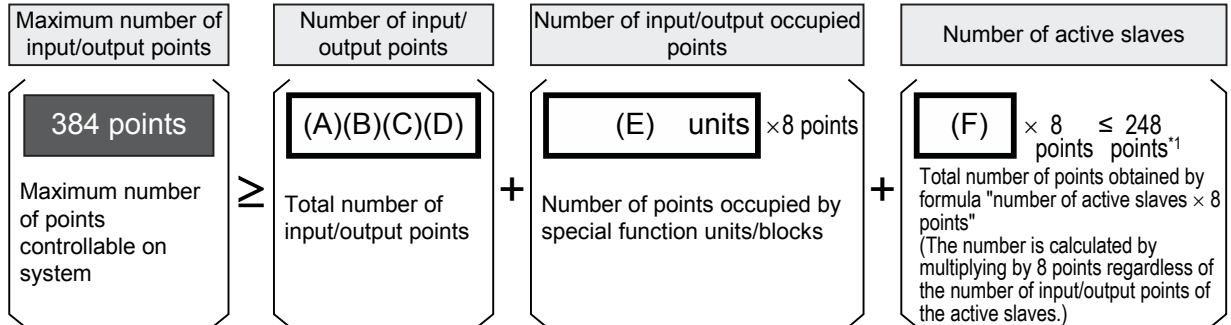

For details, refer to Subsection 6.3.1.

- (A): Number of input/output points of main unit
- (B): Number of input/output points of input/output powered extension units
- (C): Number of input/output points of input/output extension blocks

- (D): Number of remote I/O points of FX2N-64CL-M or FX2N-16LNK-M
- (E): Number of input/output points occupied by special function units/blocks
- (F): Number of active slaves connected to AS-i system master block

*1. Up to 31 slaves can be connected to the AS-i system master block.
The maximum number is calculated by the formula "8 points × number of slaves" regardless of the number of I/O points used on one slave.
For details, refer to AS-i System User's Manual.

2. Procedures for calculating number of input/output points based on example of system configuration

For the main unit, input/output powered extension units/blocks and AS-i system, the number of input/output points and the total number of points are restricted.

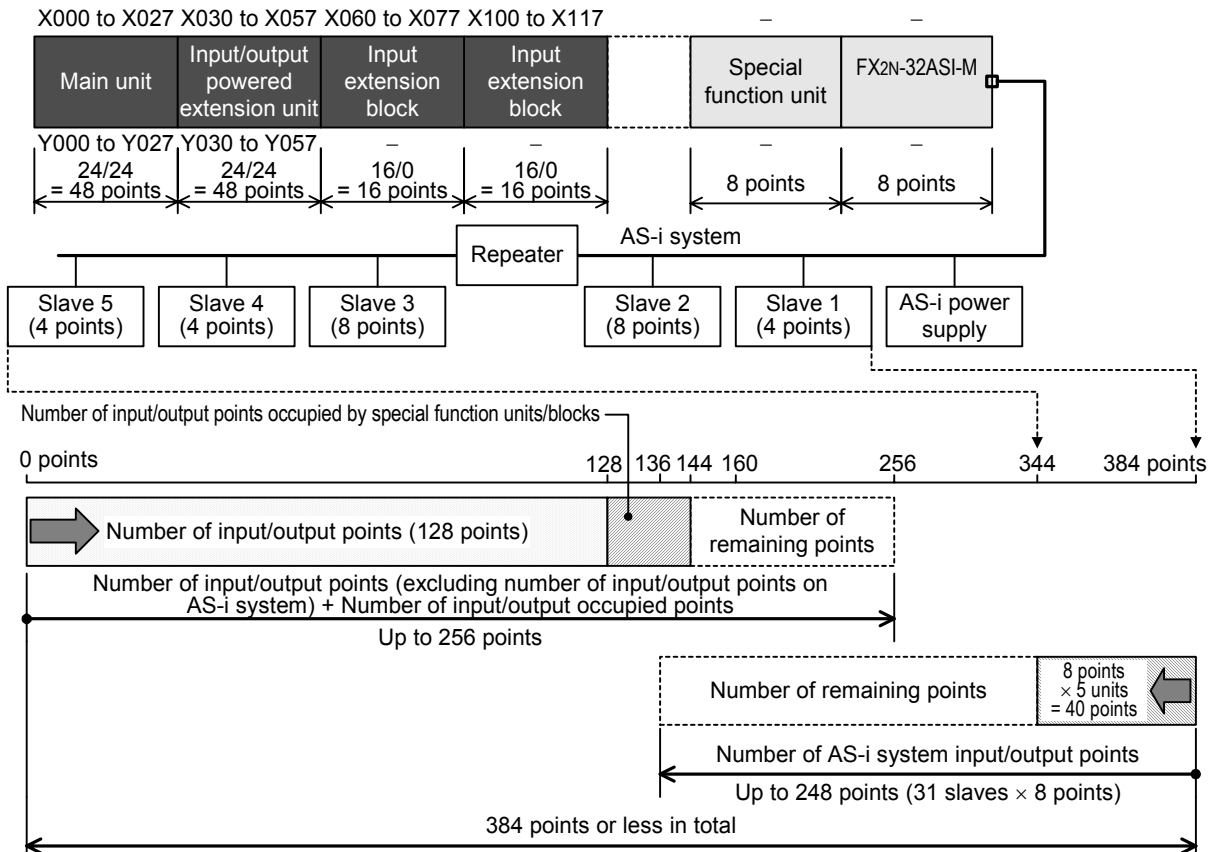

6.4 Number of Connected Special Extension Devices (Including Extension Cable)

6.4.1 Expansion board and special adapter

The number of connected special adapters is restricted depending on the type of special adapters attached as explained below.

The number of communication and CF card special adapters is restricted depending on the combination of an expansion board.

The number of special adapters other than communication and CF card adapters is restricted as shown in the following table.

Type and function of expansion board to be used	Number of connectable special adapters of each type				
	Communi- cation	CF card	Analog	High-speed input	High-speed output
When expansion board is not used	Cannot be connected.			2 unit	2 unit
When FX3U-232-BD, FX3U-422-BD, FX3U-485-BD, FX3U-USB-BD or FX3U-8AV-BD is used	Only 1unit		4 unit	2 unit	2 unit
When FX3U-CNV-BD is used	2 unit*1	1unit	4 unit	2 unit	2 unit

*1. When a CF card special adapter is used, only 1 unit can be connected.

6.4.2 Special function units/blocks, High-speed input/output special adapter

Up to eight special function units/blocks can be connected in one system.

When connecting the following products, take into consideration the combination, number of units/blocks and connecting order.

Type	Limitations
FX3U-16CCL-M	<ul style="list-style-type: none"> Only one unit can be connected to a single PLC main unit. This master cannot be used together with FX2N-16CCL-M and/or FX2N-32ASI-M.
FX2N-16CCL-M	<ul style="list-style-type: none"> When some units are used, a remote I/O station cannot be connected to the second and following master stations. This master cannot be used together with FX3U-16CCL-M and/or FX2N-32ASI-M.
FX2N-32ASI-M	<ul style="list-style-type: none"> Only one unit can be connected to a single PLC main unit. This master cannot be used together with FX3U-16CCL-M and/or FX2N-16CCL-M.
FX3U-64CCL	<ul style="list-style-type: none"> Only one unit can be connected to a single PLC main unit.
FX2N-1RM(-E)-SET	<ul style="list-style-type: none"> Up to 3 units can be sequentially connected to the end of a system. However, when three units are connected, they are counted as one unit, and the number of input/output occupied points is 8.
FX0N-3A FX2N-2AD FX2N-2DA FX3U-4HSX-ADP FX3U-2HSY-ADP	<p>When any of these products is connected to a FX2N Series input/output powered extension unit, the current consumption is restricted.</p> <p>The total current consumption of FX0N-3A, FX2N-2AD and FX2N-2DA must be the following value or less.</p> <ul style="list-style-type: none"> FX2N-32E□:190mA or less FX2N-48E□:300mA or less <p>The 5 special function units listed on the left have restrictions in current consumption (internal 24V DC) at startup when connected to FX3U Series main units (DC power type).</p> <p>At the startup of an FX0N-3A, FX2N-2AD, FX2N-2DA, FX3U-4HSX-ADP or FX3U-2HSY-ADP, make sure to set the total current consumption (internal 24V DC) less than the following values:</p> <ul style="list-style-type: none"> FX3U-16, 32M□/DS(S) : 640mA FX3U-48, 64, 80M□/DS(S): 800mA

6.4.3 Extension cable

One extension cable can be used in a system. The type of cable varies according to the product being connected.

- FX0N-65EC
- FX0N-30EC
- FX2N-GM-65EC (for FX2N-10GM and FX2N-20GM)

6.5 Expansion of Main Unit (Calculation of Current Consumption)

The amount of connectable extension equipment to the main unit varies, depending on the main unit type. Please select equipment compatible with the main unit used.

There are three types of main units:

- AC power supply/DC input type: FX3U-□□M□/ES(S)
- DC power supply type : FX3U-□□M□/DS(S)
- AC power supply/AC input type: FX3U-□□MR/UA1

1. When an AC power supply/DC input type main unit is used

- When only input/output extension devices are added, use the quick reference matrix.

Caution

Except for the FX2N-8ER and FX2N-8ER-ES/UL.

→ Refer to Subsection 6.5.1 "Quick reference matrix - when only input/output devices are added (AC Power Supply/DC Input Type)".

- When special extension devices, FX2N-8ER or FX2N-8ER-ES/UL are added, calculate the current consumption to ensure that the total current to be consumed by the added extension devices can be supplied by the built-in power supply.

→ Refer to Subsection 6.5.2 "When special extension devices are also added [calculation of current consumption] (AC Power Supply/DC Input Type)".

2. When a DC power supply type main unit is used

- When only input/output extension devices are added, use the quick reference matrix.

Caution

Except for the FX2N-8ER and FX2N-8ER-ES/UL.

→ Refer to Subsection 6.5.3 "Quick reference matrix [when only input/output devices are added] (DC Power Type)".

- When special extension devices, FX2N-8ER or FX2N-8ER-ES/UL are added, calculate the current consumption to ensure that the 5V DC and the internal 24V DC power can supply the total current required by the added extension devices.

When the added extension devices include the FX0N-3A, FX2N-2AD, FX2N-2DA, FX3U-4HSX-ADP or FX3U-2HSY-ADP, calculate the current consumption (internal 24V DC) at startup.

→ Refer to Subsection 6.5.4 "When special extension devices are also added [calculation of current consumption] (DC Power Type)".

3. When an AC power supply/AC input type main unit is used

- When only input/output extension devices are added, use the quick reference matrix.

Caution

Except for the FX2N-8ER and FX2N-8ER-ES/UL.

→ Refer to Subsection 6.5.5 "Quick reference matrix [when only input/output devices are added] (AC Power Supply/AC Input Type)".

- When special extension devices, FX2N-8ER or FX2N-8ER-ES/UL are added, calculate the current consumption to ensure that the 5V DC and the internal 24V DC power can supply the total current required by the added extension devices.

→ Refer to Subsection 6.5.6 "When special extension devices are also added [calculation of current consumption] (AC Power Supply/AC Input Type)".

6.5.1 Quick reference matrix - when only input/output devices are added (AC Power Supply/DC Input Type)

In the following quick reference matrix, the value at the intersection of the number of input points to be added (horizontal axis) with the number of output points to be added (vertical axis) indicates the remaining power supply capacity.

Caution

When the FX2N-8ER or FX2N-8ER-ES/UL are added, refer to Subsection 6.5.2.

1 Select the input/output extension block (number of points) to be connected to the main unit.

Check that the number of input/output points can be added.

When connecting the FX3U-1PSU-5V extension power supply unit to a system where the nearest upstream unit to the FX3U-1PSU-5V is a main unit, include the current consumption by the input extension blocks connected to the FX3U-1PSU-5V when calculating the total current consumption of the main unit.

1. AC power supply/DC input type

- 1) FX3U-16MR/ES, FX3U-16MT/ES, FX3U-16MT/ESS, FX3U-32MR/ES, FX3U-32MT/ES, FX3U-32MT/ESS, FX3U-32MS/ES

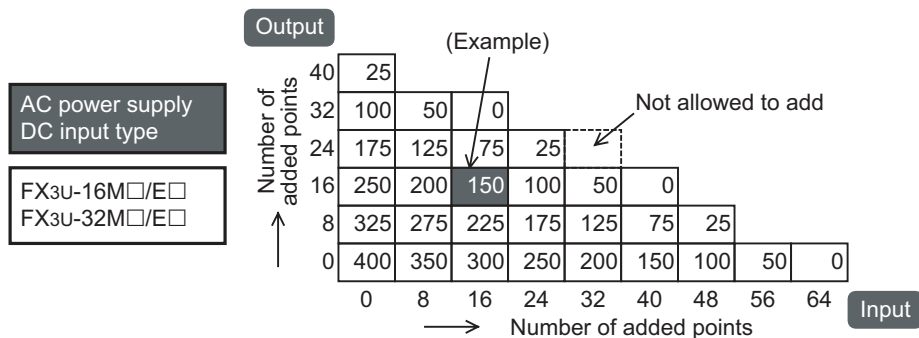

(Example) When a 16-input and 16-output point extension block is connected to FX3U-16MR/ES, the current of the 24V DC service power supply becomes 150 mA or less.

- 2) FX3U-48MR/ES, FX3U-48MT/ES, FX3U-48MT/ESS, FX3U-64MR/ES, FX3U-64MT/ES, FX3U-64MT/ESS, FX3U-64MS/ES, FX3U-80MR/ES, FX3U-80MT/ES, FX3U-80MT/ESS, FX3U-128MR/ES, FX3U-128MT/ES, FX3U-128MT/ESS

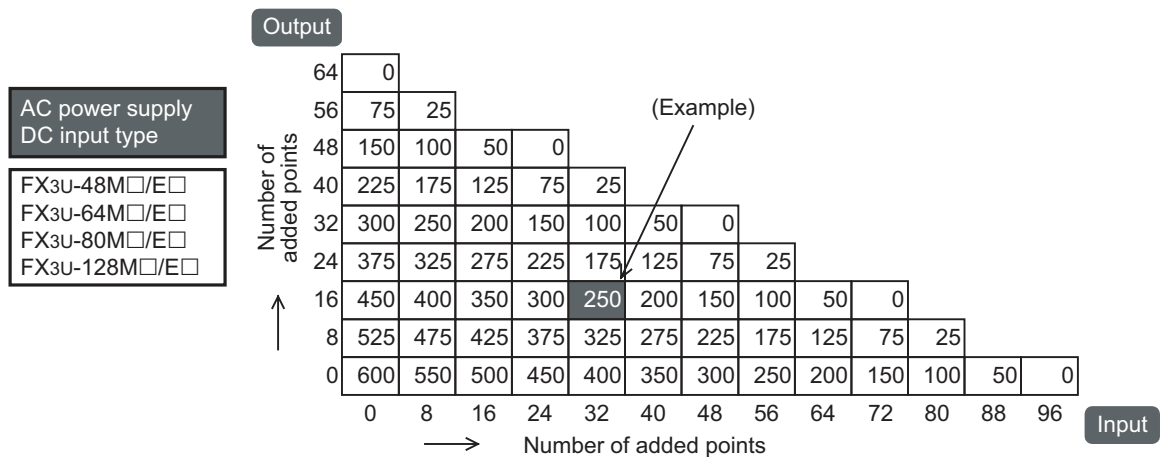

(Example) When a 32-input and 16-output point extension block is connected to FX3U-48MR/ES, the current of the 24V DC service power supply becomes 250 mA or less.

2 Confirm the current capacity of 24V DC service power supply from the value shown in the quick reference matrix.

This remaining power supply capacity (current) can be used as a power supply to external loads (sensors or the like) by the user.

When special adapters and special function units/blocks are connected, it is necessary to consider whether they can be covered by this remaining power supply capacity.

- 1 Introduction
- 2 Features and Part Names
- 3 Product Introduction
- 4 Specifications
- 5 Version and Peripheral Devices
- 6 System Configuration
- 7 Input/Output Nos., Unit Nos.
- 8 Installation
- 9 Preparation and Power Supply Wiring
- 10 Input Wiring

6.5.2 When special extension devices are also added [calculation of current consumption] (AC Power Supply/DC Input Type)

1 Select a main unit.

Select a main unit.

Select one main unit appropriate to the required number of input/output points from the following table.

Classification	Type	Input specifications	Output specifications	Number of input/output points [points]	Capacity of built-in power supply	
					5V DC power supply [mA]	24V DC service power supply [mA]
				1 -1	1 -2	1 -3
A main unit	FX3U-16MR/ES	24V DC	Relay	16	500	400
	FX3U-16MT/ES		Transistor (sink)	16		
	FX3U-16MT/ESS		Transistor (source)	16		
	FX3U-32MR/ES		Relay	32		
	FX3U-32MT/ES		Transistor (sink)	32		
	FX3U-32MT/ESS		Transistor (source)	32		
	FX3U-32MS/ES		Triac	32		
	FX3U-48MR/ES		Relay	48		
	FX3U-48MT/ES		Transistor (sink)	48		
	FX3U-48MT/ESS		Transistor (source)	48		
	FX3U-64MR/ES		Relay	64		
	FX3U-64MT/ES		Transistor (sink)	64		
	FX3U-64MT/ESS		Transistor (source)	64		
	FX3U-64MS/ES		Triac	64		
	FX3U-80MR/ES		Relay	80		
	FX3U-80MT/ES		Transistor (sink)	80		
	FX3U-80MT/ESS		Transistor (source)	80		
	FX3U-128MR/ES		Relay	128		
	FX3U-128MT/ES		Transistor (sink)	128		
	FX3U-128MT/ESS		Transistor (source)	128		
						600

When the number of input/output points is insufficient, add input/output extension blocks.

2 Enter the specifications for the selected main unit.

Enter the number of input/output points and power supply type of the main unit according to the above table.

	Classification	Number of connected units	Type	Number of input/output points [points]	Capacity of built-in power supply	
					5V DC power supply [mA]	24V DC service power supply [mA]
				1 -1	1 -2	1 -3
1 With built-in power supply	A main unit	1	FX3U-			
		Example of entry→	FX3U-32MR/ES	32	500	400

3 Enter the specifications for the products to be added.

Enter the data on the input/output extension blocks and special function units/blocks to be connected to the main unit in the following table, and calculate the current.

→ For data on the number of input/output occupied points and current consumption of each type, refer to Section 6.8.

	Classification	Number of connected units	Type	Number of input/output (occupied) points [points]	Calculation of current consumption of built-in power supply	
					5V DC power supply [mA]	24V DC power supply [mA]
Enter the products connected to the main unit	B Expansion board	1	FX3U-	-		-
	C Special adapter	10	FX3U-	-		
			FX3U-	-		
			FX3U-	-		
			FX3U-	-		
			FX3U-	-		
			FX3U-	-		
			FX3U-	-		
			FX3U-	-		
			FX3U-	-		
			FX3U-	-		
	D2 Input/output extension block*	-	FX2N-		-	
			FX2N-		-	
			FX2N-		-	
			FX2N-		-	
			FX2N-		-	
			FX2N-		-	
			FX2N-		-	
			FX2N-		-	
			FX2N-		-	
FX2N-				-		
E Special function unit/block	8	FX0N/FX2N/FX3U-				
		FX0N/FX2N/FX3U-				
		FX0N/FX2N/FX3U-				
		FX0N/FX2N/FX3U-				
		FX0N/FX2N/FX3U-				
		FX0N/FX2N/FX3U-				
		FX0N/FX2N/FX3U-				
		FX0N/FX2N/FX3U-				
G Display module	1	FX3U-7DM	-		-	
				2 -1	2 -2	2 -3
Calculate the totals						

* When connecting the FX3U-1PSU-5V extension power supply unit to a system where the nearest upstream unit to the FX3U-1PSU-5V is a main unit, also enter the current consumption and number of occupied I/O points for the input extension blocks (including FX2N-8ER-ES/UL and FX2N-8ER) that are connected to the FX3U-1PSU- 5V.

2

1	Introduction
2	Features and Part Names
3	Product Introduction
4	Specifications
5	Version and Peripheral Devices
6	System Configuration
7	Input/Output Nos., Unit Nos.
8	Installation
9	Preparation and Power Supply Wiring
10	Input Wiring

4 Determine whether the devices can be connected to the main unit.

Calculate the current to confirm whether the selected extension devices can be connected.

1. Calculate the current consumption of the built-in 24V DC power supply (24V DC service power supply).

The value obtained by this calculation (when the value is positive) indicates the remaining capacity of 24V DC service power supply, and the capacity can be used for external loads.

Capacity of 24V DC power supply	Current consumption	Calculation result
Main unit	Total of current consumed by extension devices	
1 -3 mA	2 -3 mA	= [] mA \geq 0mA

2. Calculate the current consumption of the built-in 5V DC power supply.

Capacity of 5V DC power supply	Current consumption	Calculation result
Main unit	Total of current consumed by extension devices	
1 -2 mA	1 -3 mA	= [] mA \geq 0mA

If the calculation results for the current consumption for the 24V DC power supply and 5V DC power supply are negative values, the current consumption exceeds the capacity of the built-in power supply. Reconfigure the system configuration, adding input/output powered extension units or extension power supply units.

If the calculation results for the current consumption for the 24V DC power supply and 5V DC power supply are negative values, add an input/output powered extension unit.

→ Refer to Section 6.6 "Expansion of FX2N Series I/O Powered Extension Unit (Calculation of Current Consumption)"

If the calculation results for the current consumption by 5V DC is a negative value, add an extension power supply unit (FX3U-1PSU-5V).

→ Refer to Section 6.7 "Expansion of Extension Power Supply Unit (FX3U-1PSU-5V)"

6.5.3 Quick reference matrix [when only input/output devices are added] (DC Power Type)

The following matrix shows the expandable units up to the ○ mark, where the desired inputs (horizontal axis) and outputs (vertical axis) intersect. System are expandable up to ● mark when the supply voltage is 16.8V to 19.2V.

Caution

When FX2N-8ER and FX2N-8ER-ES/UL are added, refer to Subsection 6.5.4.

Select the input/output extension block (number of points) to be connected to the main unit

The DC power type main units have restrictions in expandable I/O points since they lack a built-in service power supply.

DC power supply/DC input type

- 1) FX3U-16MR/DS, FX3U-16MT/DS, FX3U-16MT/DSS, FX3U-32MR/DS, FX3U-32MT/DS, FX3U-32MT/DSS
(These main units do not have a built-in 24V DC service power supply.)

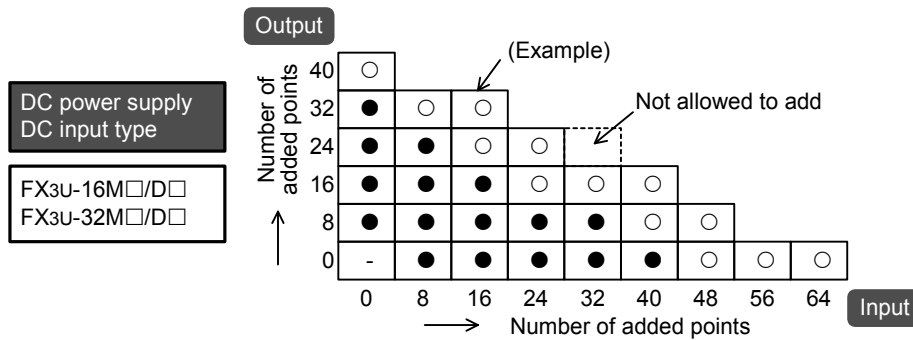

- (Example) When adding 16 inputs to FX3U-16MR/DS, a maximum of 32 outputs are expandable.
Note : When adding 16 inputs under the supply voltage 16.8V to 19.2V, a maximum of 16 outputs are expandable.

- 2) FX3U-48MR/DS, FX3U-48MT/DS, FX3U-48MT/DSS, FX3U-64MR/DS, FX3U-64MT/DS, FX3U-64MT/DSS, FX3U-80MR/DS, FX3U-80MT/DS, FX3U-80MT/DSS
(These main units do not have a built-in 24V DC service power supply.)

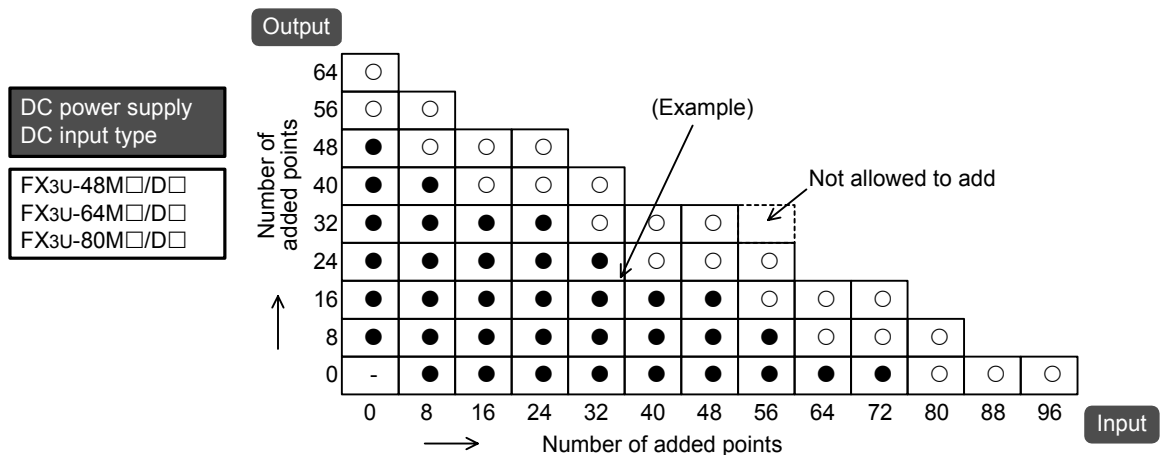

- (Example) When adding 32 inputs to FX3U-48MR/DS, a maximum of 40 outputs are expandable.
Note : When adding 32 inputs under the supply voltage 16.8V to 19.2V, a maximum of 24 outputs are expandable.

1	Introduction
2	Features and Part Names
3	Product Introduction
4	Specifications
5	Version and Peripheral Devices
6	System Configuration
7	Input/Output Nos., Unit Nos.
8	Installation
9	Preparation and Power Supply Wiring
10	Input Wiring

6.5.4 When special extension devices are also added [calculation of current consumption] (DC Power Type)

1 Select a main unit.

Select a main unit.

Select one main unit appropriate to the required number of input/output points from the following table.

Classification	Type	Input specifications	Output specifications	Number of input/output points [points]	Current supply at startup [mA]	Capacity of built-in power supply	Power supply for internal 24V DC [mA]
						5V DC power supply [mA]	
				1 -1	1 -2	1 -3	1 -4
A main unit	FX3U-16MR/DS	24V DC	Relay	16	640	500	400*1
	FX3U-16MT/DS		Transistor (sink)	16			
	FX3U-16MT/DSS		Transistor (source)	16			
	FX3U-32MR/DS		Relay	32			
	FX3U-32MT/DS		Transistor (sink)	32			
	FX3U-32MT/DSS		Transistor (source)	32			
	FX3U-48MR/DS		Relay	48	800		600*2
	FX3U-48MT/DS		Transistor (sink)	48			
	FX3U-48MT/DSS		Transistor (source)	48			
	FX3U-64MR/DS		Relay	64			
	FX3U-64MT/DS		Transistor (sink)	64			
	FX3U-64MT/DSS		Transistor (source)	64			
	FX3U-80MR/DS		Relay	80			
	FX3U-80MT/DS		Transistor (sink)	80			
	FX3U-80MT/DSS		Transistor (source)	80			

*1. When the supply voltage of the main unit is 16.8V to 19.2V DC, the power supply for the internal 24V DC is 250mA.

*2. When the supply voltage of the main unit is 16.8V to 19.2V DC, the power supply for the internal 24V DC is 450mA.

2 Enter the specifications for the selected main unit.

Enter the number of input/output points and power supply type of the main unit according to the above table.

	Classification	Number of connected units	Type	Number of input/output points [points]	Current supply at startup [mA]	Capacity of built-in power supply	Power supply for internal 24V DC [mA]
						5V DC power supply [mA]	
				1 -1	1 -2	1 -3	1 -4
1 With built-in power supply	A main unit	1	FX3U-				
Example of entry→ FX3U-32MR/DS				32	640	500	400

3 Enter the specifications for the products to be added.

Enter the data on the special function units/blocks to be connected to the main unit in the following table, and calculate the current.

→ For data on the number of input/output occupied points and current consumption of each type, refer to Section 6.8.

	Classification	Number of connected units	Type	Number of input/output (occupied) points [points]	Current consumption at startup [mA]	Calculation of current consumption of built-in power supply	
						5V DC power supply [mA]	Internal 24V DC [mA]
Enter the products connected to the main unit.	B Expansion board	1	FX3U-	-	-		-
	C Special adapter	10	FX3U-	-			
			FX3U-	-			
			FX3U-	-			
			FX3U-	-			
			FX3U-	-			
			FX3U-	-			
			FX3U-	-			
			FX3U-	-			
			FX3U-	-			
			FX3U-	-			
	D2 Input/output extension block	-	FX2N-		-	-	
			FX2N-		-	-	
			FX2N-		-	-	
			FX2N-		-	-	
			FX2N-		-	-	
			FX2N-		-	-	
			FX2N-		-	-	
			FX2N-		-	-	
			FX2N-		-	-	
			FX2N-		-	-	
	E Special function unit/block	8	FX0N/FX2N/FX3U-				
			FX0N/FX2N/FX3U-				
			FX0N/FX2N/FX3U-				
			FX0N/FX2N/FX3U-				
FX0N/FX2N/FX3U-							
FX0N/FX2N/FX3U-							
FX0N/FX2N/FX3U-							
FX0N/FX2N/FX3U-							
G Display module	1	FX3U-7DM	-	-		-	
				2 -1	2 -2	2 -3	2 -4
Calculate the totals.							

2

1	Introduction
2	Features and Part Names
3	Product Introduction
4	Specifications
5	Version and Peripheral Devices
6	System Configuration
7	Input/Output Nos., Unit Nos.
8	Installation
9	Preparation and Power Supply Wiring
10	Input Wiring

4 Determine whether the devices can be connected to the main unit.

Calculate the current to confirm whether the selected extension devices can be connected.

1. Calculate the current consumption at startup.

Current supply at startup [mA]	Current consumption at startup [mA]	Calculation result
Main unit	Total of current consumed by extension devices	
1 -2 mA	2 -2 mA	= [] mA \geq 0mA

2. Calculate the current consumption of the internal 24V DC.

The positive value from the calculation means it is expandable.

Power supply capacity for internal 24V DC	Current consumption	Calculation result
Main unit	Total of current consumed by extension devices	
1 -4 mA	2 -4 mA	= [] mA \geq 0mA

3. Calculate the current consumption of the built-in 5V DC power supply.

Capacity of 5V DC power supply	Current consumption	Calculation result
Main unit	Total of current consumed by extension devices	
1 -3 mA	2 -3 mA	= [] mA \geq 0mA

If the calculation results for the current consumption for the startup, the internal 24V DC power supply and 5V DC power supply are negative values, the current consumption exceeds the capacity of the built-in power supply.

Reexamine the system configuration adding input/output powered extension units.

→ Refer to Section 6.6 "Expansion of FX2N Series I/O Powered Extension Unit (Calculation of Current Consumption)".

6.5.5 Quick reference matrix [when only input/output devices are added] (AC Power Supply/AC Input Type)

The following matrix shows the expandable units up to the ○ mark, where the desired inputs (horizontal axis) and outputs (vertical axis) intersect.

Caution

When FX2N-8ER and FX2N-8ER-ES/UL are added, refer to Subsection 6.5.6.

Select the input/output extension block (number of points) to be connected to the main unit

Since the AC power supply/AC input type main unit does not have a built-in service power supply, use an external power supply to connect a DC input type extension block.

Also take into account the limitations on the number of expansion I/O points that can be added to an AC power supply/AC input type main unit. When connecting the FX3U-1PSU-5V extension power supply unit to a system where the nearest upstream unit to the FX3U-1PSU-5V is a main unit, include the current consumption by the input extension blocks connected to the FX3U-1PSU-5V when calculating the total current consumption of the main unit.

AC power supply/AC input type

1) FX3U-32MR/UA1

(These main units do not have a built-in 24V DC service power supply.)

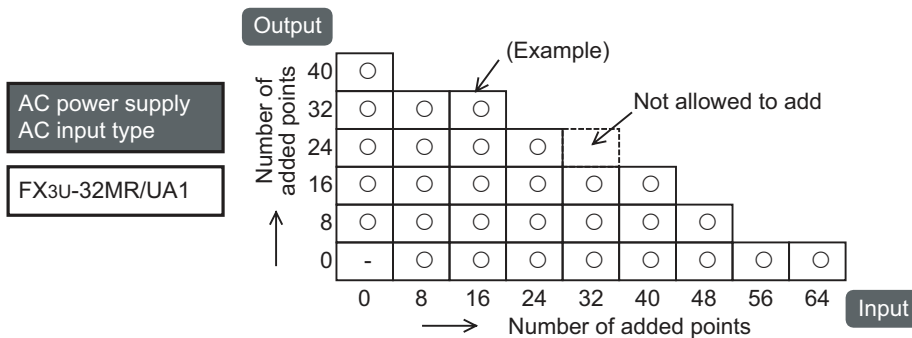

(Example) When adding 16 inputs to FX3U-32MR/UA1, a maximum of 32 outputs are expandable.

2) FX3U-64MR/UA1

(These main units do not have a built-in 24V DC service power supply.)

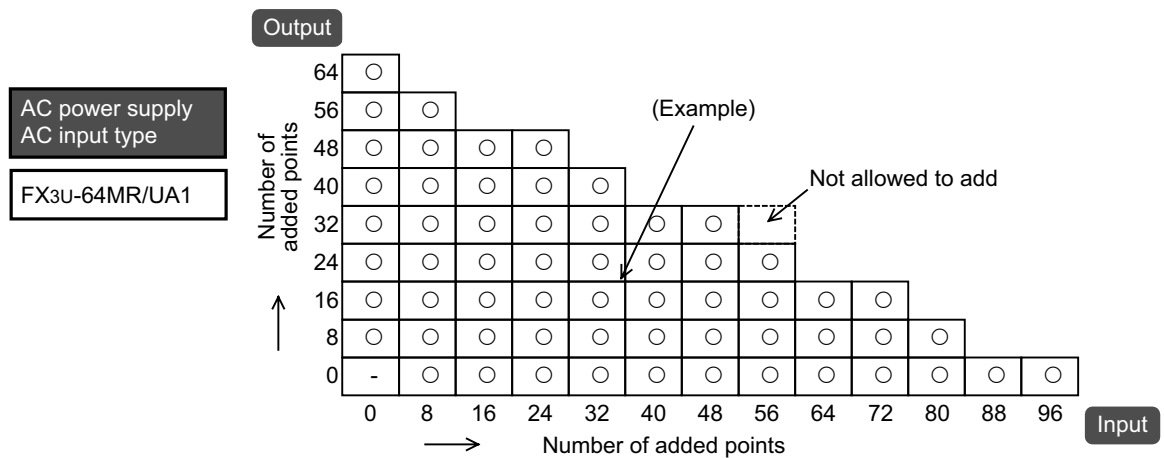

(Example) When adding 32 inputs to FX3U-64MR/UA1, a maximum of 40 outputs are expandable.

1 Introduction

2 Features and Part Names

3 Product Introduction

4 Specifications

5 Version and Peripheral Devices

6 System Configuration

7 Input/Output Nos., Unit Nos.

8 Installation

9 Preparation and Power Supply Wiring

10 Input Wiring

6.5.6 When special extension devices are also added [calculation of current consumption] (AC Power Supply/AC Input Type)

1 Select a main unit.

Select a main unit.

Select one main unit appropriate to the required number of input/output points from the following table.

A	Classification	Type	Input specifications	Output specifications	Number of input/output points [points]	Capacity of built-in power supply	Power supply for internal 24V DC [mA]
						5V DC power supply[mA]	
					1 -1	1 -2	1 -3
A main unit	FX3U-32MR/UA1	100V AC	Relay	32	500	400	
	FX3U-64MR/UA1			64			600

2 Enter the specifications for the selected main unit.

Enter the number of input/output points and power supply type of the main unit according to the above table.

1	Classification	Number of connected units	Type	Number of input/output points [points]	Capacity of built-in power supply	Power supply for internal 24V DC [mA]
					5V DC power supply [mA]	
				1 -1	1 -2	1 -3
With built-in power supply	A main unit	1	FX3U-			
Example of entry→ FX3U-32MR/UA1				32	500	400

3 Enter the specifications for the products to be added.

Enter the data on the special function units/blocks to be connected to the main unit in the following table, and calculate the current.

→ For data on the number of input/output occupied points and current consumption of each type, refer to Section 6.8.

	Classification	Number of connected units	Type	Number of input/output points [points]	Calculation of current consumption of built-in power supply	
					5V DC power supply [mA]	Internal 24V DC [mA]
Enter the products connected to the main unit.	B Expansion board	1	FX3U-	-		-
	C Special adapter	10	FX3U-	-		
			FX3U-	-		
			FX3U-	-		
			FX3U-	-		
			FX3U-	-		
			FX3U-	-		
			FX3U-	-		
			FX3U-	-		
			FX3U-	-		
			FX3U-	-		
	D2 Input/output extension block*	-	FX2N-		-	
			FX2N-		-	
			FX2N-		-	
			FX2N-		-	
			FX2N-		-	
			FX2N-		-	
			FX2N-		-	
			FX2N-		-	
			FX2N-		-	
FX2N-				-		
FX2N-				-		
FX2N-				-		
E Special function unit/block	8	FX0N/FX2N/FX3U-				
		FX0N/FX2N/FX3U-				
		FX0N/FX2N/FX3U-				
		FX0N/FX2N/FX3U-				
		FX0N/FX2N/FX3U-				
		FX0N/FX2N/FX3U-				
		FX0N/FX2N/FX3U-				
		FX0N/FX2N/FX3U-				
G Display module	1	FX3U-7DM	-		-	
				2 -1	2 -2	2 -3
Calculate the totals.						

* When connecting the FX3U-1PSU-5V extension power supply unit to a system where the nearest upstream unit to the FX3U-1PSU-5V is a main unit, also enter the current consumption and number of occupied I/O points for the input extension blocks (including FX2N-8ER-ES/UL and FX2N-8ER) that are connected to the FX3U-1PSU- 5V.

2

1	Introduction
2	Features and Part Names
3	Product Introduction
4	Specifications
5	Version and Peripheral Devices
6	System Configuration
7	Input/Output Nos., Unit Nos.
8	Installation
9	Preparation and Power Supply Wiring
10	Input Wiring

4 Determine whether the devices can be connected to the main unit.

Calculate the current to confirm whether the selected extension devices can be connected.

1. Calculate the current consumption of the internal 24V DC.

The positive value from the calculation means it is expandable.

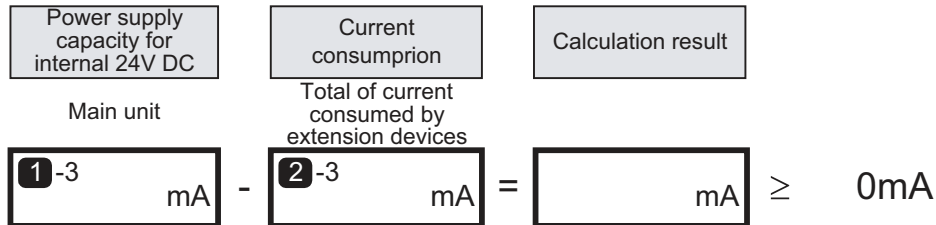

2. Calculate the current consumption of the built-in 5V DC power supply.

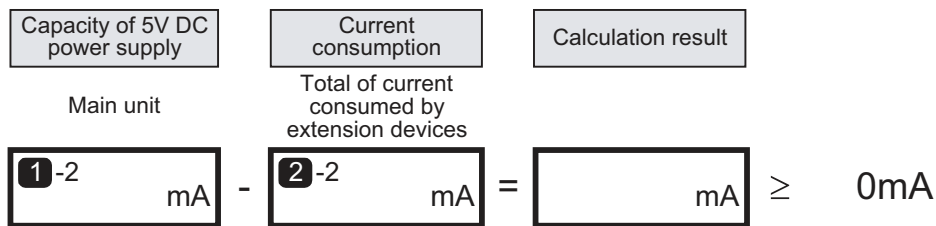

If the calculation results for the current consumption for the startup, the internal 24V DC power supply and 5V DC power supply are negative values, the current consumption exceeds the capacity of the built-in power supply.

Reexamine the system configuration adding input/output powered extension units.

→ Refer to Section 6.6 "Expansion of FX2N Series I/O Powered Extension Unit (Calculation of Current Consumption)".

If the calculation results for the current consumption for the internal 24V DC power supply and 5V DC power supply are negative values, add an input/output powered extension unit.

→ Refer to Section 6.6 "Expansion of FX2N Series I/O Powered Extension Unit (Calculation of Current Consumption)".

If the calculation results for the current consumption by 5V DC is a negative value, add an extension power supply unit (FX3U-1PSU-5V).

→ Refer to Section 6.7 "Expansion of Extension Power Supply Unit (FX3U-1PSU-5V)".

6.6 Expansion of FX2N Series I/O Powered Extension Unit (Calculation of Current Consumption)

If the selected devices in the previous section cannot be connected due to a shortage of current from the main unit's built-in 24V DC service power supply, add an input/output powered extension unit. Since input/output powered extension units have built-in input/output terminals, reexamine the input/output devices connected to the main unit to ensure the required number of points.

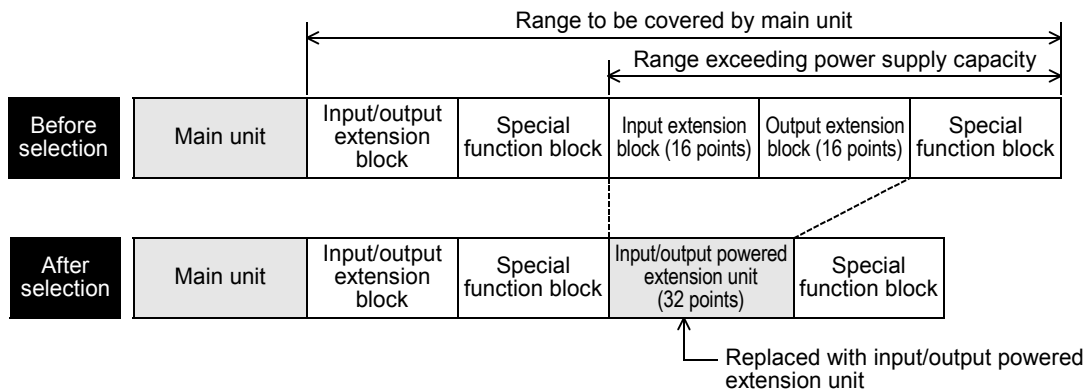

Determine whether extension devices can be connected to the input/output powered extension unit by the following method.

- When only input/output extension devices are added, use the quick reference matrix.
→ Refer to Subsection 6.6.1 "Quick reference matrix (when only input/output devices are added)".
- When also special extension devices are added, calculate the current consumption to ensure that the total current to be consumed by the added extension devices can be supplied by the built-in power supply.
→ Refer to Subsection 6.6.2 "When special extension devices are also added (calculation of current consumption)".

6.6.1 Quick reference matrix (when only input/output devices are added)

In the following quick reference matrix, the value at the intersection of the number of input points to be added (horizontal axis) with the number of output points to be added (vertical axis) indicates the remaining power supply capacity.

1 Select the input/output points extension block (number of points) to be connected to the main unit.

Check that the number of input/output points can be added.

When connecting the FX3U-1PSU-5V extension power supply unit to a system where the nearest upstream unit to the FX3U-1PSU-5V is an input/output powered extension unit, include the current consumption by the input extension blocks (including FX2N-8ER-ES/UL and FX2N-8ER) connected to the FX3U-1PSU-5V when calculating the total current consumption of the input/output powered extension unit.

1. AC power supply/DC input type

- 1) FX2N-32ER, FX2N-32ET, FX2N-32ES
FX2N-32ER-ES/UL, FX2N-32ET-ESS/UL

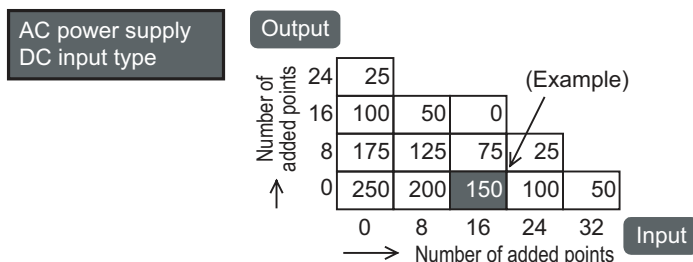

(Example) When a 16-input and 0-output point extension block is connected to FX2N-32ER, the current of the 24V DC service power supply becomes 150 mA or less.

- 2) FX2N-48ER, FX2N-48ET
 FX2N-48ER-ES/UL, FX2N-48ET-ESS/UL

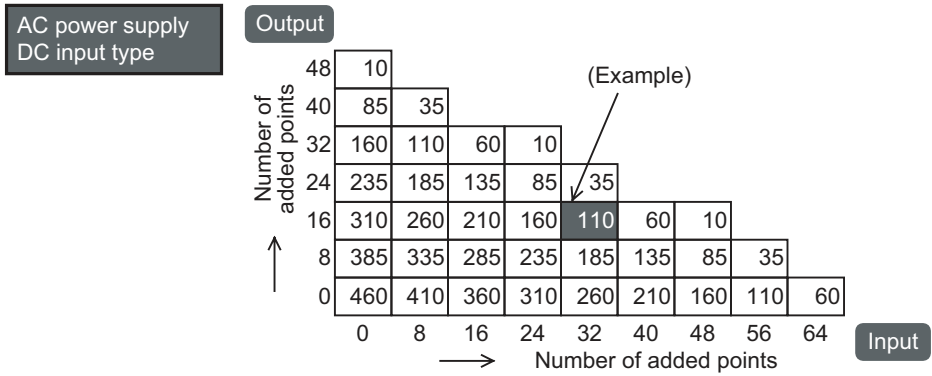

(Example) When a 32-input and 16-output point extension block is connected to FX2N-48ER, the current of 24V DC service power supply becomes 110 mA or less.

2. DC power supply/DC input type

- 1) FX2N-48ER-DS, FX2N-48ET-DSS, FX2N-48ER-D, FX2N-48ET-D
 (24V DC service power supply is not provided.)

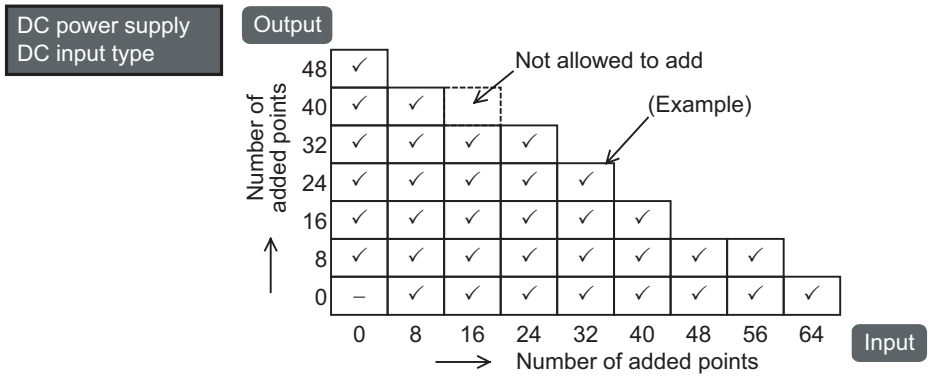

(Example) When adding 32 inputs to FX2N-48ER-DS, a maximum of 24 outputs are expandable.

3. AC power supply/AC input type

- 1) FX2N-48ER-UA1/UL
 (24V DC service power supply is not provided. To connect a DC input type extension block, an external power supply is necessary.)

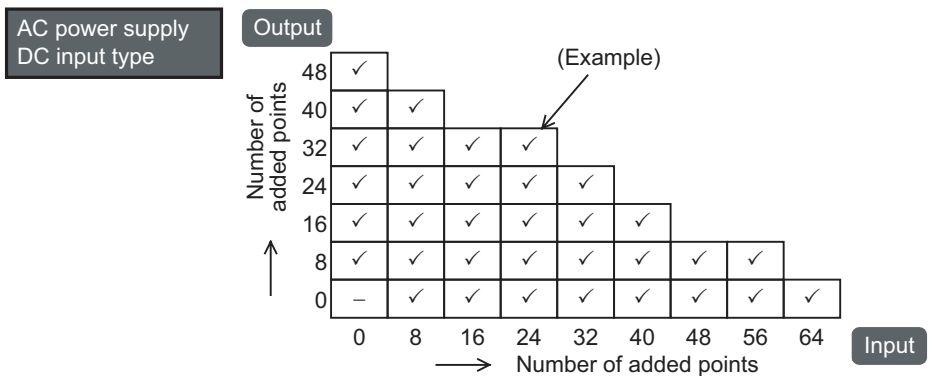

(Example) When adding 24 inputs to FX2N-48ER-UA1/UL, a maximum of 32 outputs are expandable.

2 Check the current capacity of the 24V DC service power supply based on the value shown in the quick reference matrix.

1. In case of AC power supply/DC input type

The remaining power supply capacity (current) can be used as a power supply to loads (sensors or the like). When special adapters and special function units/blocks are connected by external wiring, it is necessary to consider whether they can be covered by the remaining power supply capacity.

2. In case of DC power supply/DC input type

24V DC service power supply is not provided.

3. In case of AC power supply/AC input type

24V DC service power supply is not provided.

3 When the power supply capacity is insufficient, connect another input/output powered extension unit.

When two input/output powered extension units or more are connected, calculate the power supply capacities of the input/output extension blocks and special function units/blocks connected to them, and check the capacity.

1

Introduction

2

Features and Part Names

3

Product Introduction

4

Specifications

5

Version and Peripheral Devices

6

System Configuration

7

Input/Output Nos., Unit Nos.

8

Installation

9

Preparation and Power Supply Wiring

10

Input Wiring

6.6.2 When special extension devices are also added (calculation of current consumption)

1 Select an input/output powered extension unit.

→ For data on the number of input/output occupied points and current consumption of each type, refer to Section 6.8.

3

Power supply classification	Classification	Number of connected units	Type	Number of input/output points [points]	Capacity of built-in power supply	
					5V DC power supply [mA]	24V DC service power supply [mA]
				3-1	3-2	3-3
With built-in power supply	D1 Input/output powered extension unit	-	FX2N-			
Example of entry → FX2N-48ER-ES/UL				48	690	460

2

2 Enter the specifications for the products to be added.

Enter the data for the input/output extension blocks and special function units/blocks to be connected to the input/output powered extension unit, and calculate the current.

→ For data on the number of input/output occupied points and current consumption of each type, refer to Section 6.8.

4

Power supply classification	Classification	Number of connected units	Type	Number of input/output points [points]	Calculation of current consumption of built-in power supply	
					5V DC power supply [mA]	24V DC power supply [mA]
Enter the products connected to the input/output powered extension unit	D2 Input/output extension block*1	-	FX2N-		-	
			FX2N-		-	
			FX2N-		-	
			FX2N-		-	
			FX2N-		-	
			FX2N-		-	
			FX2N-		-	
			FX2N-		-	
			FX2N-		-	
			FX2N-		-	
			FX2N-		-	
	E Special function unit/block	8*2	FX0N/FX2N/FX3U-			
			FX0N/FX2N/FX3U-			
			FX0N/FX2N/FX3U-			
			FX0N/FX2N/FX3U-			
			FX0N/FX2N/FX3U-			
			FX0N/FX2N/FX3U-			
			FX0N/FX2N/FX3U-			
			FX0N/FX2N/FX3U-			
				4-1	4-2	4-3
Calculate the totals						

*1. When connecting the FX3U-1PSU-5V extension power supply unit to a system where the nearest upstream unit to the FX3U-1PSU-5V is input/output powered extension unit, also enter the current consumption and number of occupied I/O points for the input extension blocks (including FX2N-8ER-ES/UL and FX2N-8ER) that are connected to the FX3U-1PSU-5V.

*2. A maximum of 8 special function units/blocks are connectable, including the main unit and extension power supply unit.

3 Determine whether FX0N-3A, FX2N-2AD and FX2N-2DA can be added.

Determine the number of analog special function blocks (FX0N-3A, FX2N-2AD and FX2N-2DA) to be connected to the input/output powered extension unit by the following method.

- When connecting to FX2N-32E□

Analog special function block			Total current consumption
FX0N-3A	FX2N-2AD	FX2N-2DA	
$90\text{mA} \times \boxed{\text{units}}$	$+ 50\text{mA} \times \boxed{\text{units}}$	$+ 85\text{mA} \times \boxed{\text{units}}$	$= \boxed{\text{mA}} \leq 190\text{mA}$

- When connecting to FX2N-48E□

Analog special function block			Total current consumption
FX0N-3A	FX2N-2AD	FX2N-2DA	
$90\text{mA} \times \boxed{\text{units}}$	$+ 50\text{mA} \times \boxed{\text{units}}$	$+ 85\text{mA} \times \boxed{\text{units}}$	$= \boxed{\text{mA}} \leq 300\text{mA}$

4 Determine whether the devices can be added to the input/output powered extension unit.

Calculate the current to confirm whether the selected extension devices can be connected.

1. Calculate the current consumption of the built-in 24V DC power supply (24V DC service power supply).

The value obtained by this calculation (when the value is positive) indicates the remaining capacity of 24V DC service power supply, and the capacity can be used for external loads.

Capacity of 24V DC power supply	Current consumption	Calculation result
Input/output powered extension unit	Total of current consumed by extension devices	
$\boxed{3-3} \text{ mA}$	$-\ \boxed{4-3} \text{ mA}$	$= \boxed{\text{mA}} \geq 0\text{mA}$

2. Calculate the current consumption of the built-in 5V DC power supply.

Capacity of 5V DC power supply	Current consumption	Calculation result
Input/output powered extension unit	Total of current consumed by extension devices	
$\boxed{3-2} \text{ mA}$	$-\ \boxed{4-2} \text{ mA}$	$= \boxed{\text{mA}} \geq 0\text{mA}$

If the calculation results for the current consumption of the 24V DC power supply and 5V DC power supply are negative values, the current consumption exceeds the capacity of the built-in power supply. Reconfigure the system, adding input/output powered extension units or extension power supply units.

6.7 Expansion of Extension Power Supply Unit (FX3U-1PSU-5V)

If the selected devices in section 6.5 are not connectable due to the built-in 5V DC power shortage, add an extension power supply unit.

1 Enter the current supply specification of the extension power supply unit.

The output current of the extension power supply unit is proportional to the ambient temperature as shown by the derating curve below. Enter the output current value, based on this derating curve. Also verify that the number of occupied input/output points from input/output extension block(s) connected to the extension power supply unit is less than 32.

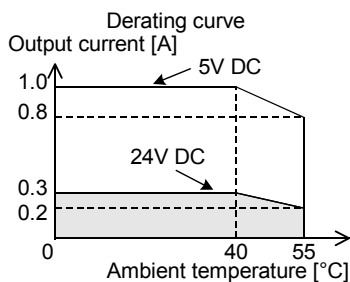

5

Power supply classification	Classification	Number of connected units	Type	Capacity of built-in power supply		Connectable I/O occupied points [points]
				5V DC power supply [mA]	Power supply for internal 24V DC [mA]	
				5-1	5-2	5-3
With built-in power supply	H1 Extension power supply unit	-	FX3U-1PSU-5V			32

2 Enter the specifications for the products to be added.

Enter the data on the input/output extension blocks and special function units/blocks to be connected to the input/output powered extension unit, and calculate the current.

→ For data on the number of input/output occupied points and current consumption of each type, refer to Section 6.8.

Power supply classification	Classification	Number of connected units	Type	Capacity of built-in power supply		Number of I/O occupied points *1 {points}
				5V DC power supply [mA]	Power supply for internal 24V DC [mA]	
Enter the products connected to the extension power supply unit	D2 Input/output extension block*2	-	FX2N-	-		
			FX2N-	-		
			FX2N-	-		
			FX2N-	-		
	E Special function unit/block	8*3	FX0N/FX2N/FX3U-			-
			FX0N/FX2N/FX3U-			-
			FX0N/FX2N/FX3U-			-
			FX0N/FX2N/FX3U-			-
			FX0N/FX2N/FX3U-			-
			FX0N/FX2N/FX3U-			-
			FX0N/FX2N/FX3U-			-
			FX0N/FX2N/FX3U-			-
				6-1	6-2	6-3
Calculate the totals						

6

- *1. Input/output occupied points by special function units/blocks are excluded.
- *2. For input extension blocks (including FX2N-8ER-ES/UL, FX2N-8ER), do not include the current consumption by the internal 24V DC. Subtract the internal 24V DC current consumption from the service power supply of the input/output powered extension unit or the nearest main unit (except AC power supply/AC input type) on the upstream side of extension power supply unit.
To connect a DC input type extension block to an AC power supply/AC input type main unit, it is necessary to provide power to the extension block from an external source. Subtract the 24V DC power supply current consumption from the internal 24V DC power supply of the main unit.
→ When the main unit is on the upstream side, refer to Subsection 6.5.1 and 6.5.2.
→ When the input/output powered extension unit is on the upstream side, refer to Subsection 6.6.1 and 6.6.2.
- *3. A maximum of 8 special function units/blocks are connectable, including the main unit and the input/output powered extension unit.

1	Introduction
2	Features and Part Names
3	Product Introduction
4	Specifications
5	Version and Peripheral Devices
6	System Configuration
7	Input/Output Nos., Unit Nos.
8	Installation
9	Preparation and Power Supply Wiring
10	Input Wiring

3 Determine whether the devices can be added to the extension power supply unit.

Calculate the current to confirm whether the selected extension devices can be connected.

1. Calculate the current consumption of the built-in 5V DC power supply.

Capacity of 5V DC power supply	Current consumption	Calculation result
Extension power supply unit	Total of current consumed by extension devices	
5-1 mA	6-1 mA	mA ≥ 0mA

2. Calculate the available current supply from the internal 24V DC power supply.

Power supply capacity for internal 24V DC	Current consumption	Calculation result
Extension power supply unit	Total of current consumed by extension devices	
5-2 mA	6-2 mA	mA ≥ 0mA

3. Calculate the available input/output occupied points (excluding the occupied input/output by special function units/blocks).

Connectable I/O occupied points	Number of I/O occupied points	Calculation result
Extension power supply unit	Total of I/O occupied points by extension devices	
5-3 points	6-3 points	points ≥ 0points

If the calculation result for the 5V DC power supply is a negative value, the current consumption exceeds the power supply capacity.

Reconfigure the system with an extension power supply unit.

If the calculation results for the internal 24V DC power supply and input/output occupied points are negative values, the actual input/output occupied points exceed the connectable input/output occupied points.

Reconfigure the system with an input/output powered extension unit.

6.8 Number of Input/Output (Occupied) Points and Current Consumption

The following tables show the number of input/output points or the number of input/output occupied points for each type of device, along with the power supply type and current consumption values needed for selecting a product.

- Number of input/output points or input/output occupied points on each type of device
- Output current of 5V DC power supply and 24V DC service power supply*¹ of main unit and input/output powered extension units
- Current consumed by expansion boards, special adapters, input/output extension blocks, special function units/blocks and display module

*1. The DC power type and AC power supply/AC input type main unit does not have a 24V DC service power supply. Instead, it has an internal 24V DC power supply.

The current consumption is determined differently in the following cases.

- 5V DC and internal 24V DC are supplied to the products through an extension cable, and the current consumption must be calculated
Subtract the current consumption at the internal 24V DC as follows.
 - For the AC power supply/AC input type main unit, subtract the current consumption at the internal 24V DC from the 24V DC service power supply.
 - For the DC power type and AC power supply/AC input type main unit, subtract the current consumption at the internal 24V DC from the power supply for the internal 24V DC.
- The special function units/blocks connected to the AC power supply/AC input type main unit or to the 24V DC service power supply terminal of the input/output powered extension unit consume the external 24V DC. Include the current in the calculation of current consumption.

When the terminal is connected with an external power supply, the current is not included in the calculation of current consumption.

1

Introduction

2

Features and Part Names

3

Product Introduction

4

Specifications

5

Version and Peripheral Devices

6

System Configuration

7

Input/Output Nos., Unit Nos.

8

Installation

9

Preparation and Power Supply Wiring

10

Input Wiring

6.8.1 [A] Main units

No.	Type	Input/output		Output current (mA)	
		Number of input/output points [points]	Input/output [points]	5V DC power supply	24V DC service power supply
A					
AC power supply/24V DC input/relay output type					
A1	FX3U-16MR/ES	16	8/8	500	400
	FX3U-32MR/ES	32	16/16		600
	FX3U-48MR/ES	48	24/24		
	FX3U-64MR/ES	64	32/32		
	FX3U-80MR/ES	80	40/40		
	FX3U-128MR/ES	128	64/64		
AC power supply/24V DC input/transistor output type					
A1	FX3U-16MT/ES	16	8/8	500	400
	FX3U-16MT/ESS	16	8/8		
	FX3U-32MT/ES	32	16/16		
	FX3U-32MT/ESS	32	16/16		
	FX3U-48MT/ES	48	24/24		
	FX3U-48MT/ESS	48	24/24		
	FX3U-64MT/ES	64	32/32		600
	FX3U-64MT/ESS	64	32/32		
	FX3U-80MT/ES	80	40/40		
	FX3U-80MT/ESS	80	40/40		
	FX3U-128MT/ES	128	64/64		
	FX3U-128MT/ESS	128	64/64		
AC power supply/24V DC input/triac output type					
A1	FX3U-32MS/ES	32	16/16	500	400
	FX3U-64MS/ES	64	32/32		600
A					
No.	Type	Input/output		Output current (mA)	
		Number of input/output points [points]	Input/output [points]	5V DC power supply	24V DC service power supply
AC power supply/100V AC input/relay output type					
A2	FX3U-32MR/UA1	32	16/16	500	400
	FX3U-64MR/UA1	64	32/32		600

A

No.	Type	Input/output		Output current (mA)		Current supply at startup [mA] ^{*3}
		Number of input/output points [points]	Input/output [points]	5V DC power supply	Power supply capacity for internal 24V DC	
DC power supply/24V DC input/relay output type						
A3	FX3U-16MR/DS	16	8/8	500	400 ^{*1}	640
	FX3U-32MR/DS	32	16/16			
	FX3U-48MR/DS	48	24/24		600 ^{*2}	800
	FX3U-64MR/DS	64	32/32			
	FX3U-80MR/DS	80	40/40			
DC power supply/24V DC input/transistor output type						
A3	FX3U-16MT/DS	16	8/8	500	400 ^{*1}	640
	FX3U-16MT/DSS	16	8/8			
	FX3U-32MT/DS	32	16/16			
	FX3U-32MT/DSS	32	16/16		600 ^{*2}	800
	FX3U-48MT/DS	48	24/24			
	FX3U-48MT/DSS	48	24/24			
	FX3U-64MT/DS	64	32/32			
	FX3U-64MT/DSS	64	32/32			
	FX3U-80MT/DS	80	40/40			
FX3U-80MT/DSS	80	40/40				

- *1. When the supply voltage of the main unit is 16.8V to 19.2V DC, the power supply for the internal 24V DC is 250mA.
- *2. When the supply voltage of the main unit is 16.8V to 19.2V DC, the power supply for the internal 24V DC is 450mA.
- *3. When adding the high-speed input/output special adapters (FX3U-4HSX-ADP/FX3U-2HSY-ADP) and the analog special function blocks (only FX0N-3A/FX2N-2AD/FX2N-2DA), calculate the current supply at startup.

1	Introduction
2	Features and Part Names
3	Product Introduction
4	Specifications
5	Version and Peripheral Devices
6	System Configuration
7	Input/Output Nos., Unit Nos.
8	Installation
9	Preparation and Power Supply Wiring
10	Input Wiring

6.8.2 [B] Expansion boards

–: No need to calculate

No.	Type	Number of input/ output occupied points	Current consumed (mA)	
			5V DC	Internal 24V DC
B1	FX3U-232-BD	–	20	–
	FX3U-422-BD	–	20*1	–
	FX3U-485-BD	–	40	–
	FX3U-USB-BD	–	15	–
	FX3U-8AV-BD	–	20	–
	FX3U-CNV-BD	–	–	–

*1. When FX3U-422-BD is connected, add the current consumed by GOT/programming tool F.

GOT/programming tool

–: No need to calculate

No.	Type	Number of input/ output occupied points	Current consumed (mA)	
			5V DC	Internal 24V DC
F1	FX-30P	–	115*2	–
	FX-20P(-E)	–	150*3	–
	FX-10P(-E)	–	120	–
	FX-232AW	–	220	–
	FX-232AWC	–	220	–
	FX-232AWC-H	–	120	–
	FX-USB-AW	–	15	–
	FX-10DM(-SET0)(-E)	–	220	–
	F920GOT-BBD5-K(-E)	–	220	–

*2. When the intensity of the LCD backlight is set at the initial value 4.
If the LCD backlight is set at the maximum value 8, it is handled as "155mA".

*3. When FX-20P-RWM is used, the current is 180 mA.

6.8.3 [C] Special adapters

–: No need to calculate

No.	Type	Number of input/ output occupied points	Current consumed (mA)			Current supply at startup (mA)*1
			5V DC	Internal 24V DC	External 24V DC	
C1	FX3U-4HSX-ADP	–	30	30	0	30
	FX3U-2HSY-ADP	–	30	60	0	120
C2	FX3U-4AD-ADP	–	15	0	40	–
	FX3U-4DA-ADP	–	15	0	150	–
	FX3U-3A-ADP	–	20	0	90	–
	FX3U-4AD-PT-ADP	–	15	0	50	–
	FX3U-4AD-PTW-ADP	–	15	0	50	–
	FX3U-4AD-PNK-ADP	–	15	0	50	–
	FX3U-4AD-TC-ADP	–	15	0	45	–
	FX3U-4AD-TC-ADP	–	15	0	45	–
C3	FX3U-232ADP(-MB)	–	30	0	0	–
	FX3U-485ADP(-MB)	–	20	0	0	–
C4	FX3U-CF-ADP	–	50	0	130	–

*1. When applying the DC power type main unit, calculate the current consumption at startup.

6.8.4 [D] Input/output powered extension units/blocks

1. Input/output powered extension units

No.	Type	Input/output		Output current (mA)	
		Number of input/output points [points]	Input/output [points]	5V DC power supply	24V DC service power supply
D1	FX2N-32ER-ES/UL	32	16/16	690	250
	FX2N-32ET-ESS/UL	32	16/16		
	FX2N-32ER	32	16/16		
	FX2N-32ES	32	16/16		
	FX2N-32ET	32	16/16		
	FX2N-48ER-ES/UL	48	24/24		460
	FX2N-48ET-ESS/UL	48	24/24		
	FX2N-48ER	48	24/24		
	FX2N-48ET	48	24/24		
	FX2N-48ER-UA1/UL	48	24/24		
	FX2N-48ER-DS	48	24/24		-
	FX2N-48ET-DSS	48	24/24		
	FX2N-48ER-D	48	24/24		
	FX2N-48ET-D	48	24/24		

2. Input/output extension blocks

–: No need to calculate

No.	Type	Number of input/output points	Current consumed (mA)		
			5V DC	Internal 24V DC	External 24V DC
Types for addition of input/output					
	FX2N-8ER-ES/UL	16*	–	62.5	0
	FX2N-8ER	16*	–	62.5	0
Types for addition of input					
	FX2N-8EX-ES/UL	8	–	50	0
	FX2N-8EX	8	–	50	0
	FX2N-8EX-UA1/UL	8	–	50	0
	FX2N-16EX-ES/UL	16	–	100	0
	FX2N-16EX	16	–	100	0
	FX2N-16EX-C	16	–	100	0
	FX2N-16EXL-C	16	–	100	0
Types for addition of output					
D2	FX2N-8EYR-ES/UL	8	–	75	0
	FX2N-8EYR-S-ES/UL	8	–	75	0
	FX2N-8EYT-ESS/UL	8	–	75	0
	FX2N-8EYR	8	–	75	0
	FX2N-8EYT	8	–	75	0
	FX2N-8EYT-H	8	–	75	0
	FX2N-16EYR-ES/UL	16	–	150	0
	FX2N-16EYT-ESS/UL	16	–	150	0
	FX2N-16EYR	16	–	150	0
	FX2N-16EYT-C	16	–	150	0
	FX2N-16EYT	16	–	150	0
	FX2N-16EYS	16	–	150	0

* Four inputs and four outputs are occupied as unused numbers.

1	Introduction
2	Features and Part Names
3	Product Introduction
4	Specifications
5	Version and Peripheral Devices
6	System Configuration
7	Input/Output Nos., Unit Nos.
8	Installation
9	Preparation and Power Supply Wiring
10	Input Wiring

6.8.5 [E] Special extension devices

1. Special function blocks

E	No.	Type	Number of input/occupied output points	Current consumed (mA)			Current supply at startup [mA]*8
				5V DC	Internal 24V DC	External 24V DC	
E1		FX3U-4AD	8	110	0	90	–
		FX3U-4DA	8	120	0	160	–
		FX3U-4LC	8	160	0	50	–
		FX3U-2HC	8	245	0	0	–
		FX3U-20SSC-H	8	100	0	220	–
		FX3U-16CCL-M	8*2	0	0	240	–
		FX3U-64CCL	8	0	0	220	–
E2		FX2N-2AD	8	20	50*7	0	170
		FX2N-2DA	8	30	85*7	0	190
		FX2N-4AD	8	30	0	55	–
		FX2N-4DA	8	30	0	200	–
		FX2N-4AD-TC	8	30	0	50	–
		FX2N-4AD-PT	8	30	0	50	–
		FX2N-8AD	8	50	0	80	–
		FX2N-5A	8	70	0	90	–
		FX2N-2LC	8	70	0	55	–
		FX2N-1HC	8	90	0	0	–
		FX2N-1PG(-E)	8	55	0	40	–
		FX2N-10PG	8	120	0	70*1	–
		FX2N-232IF	8	40	0	80	–
		FX2N-16CCL-M	8*3	0	0	150	–
		FX2N-32CCL	8	130	0	50	–
		FX2N-64CL-M	8*4	190	Supplied from power supply for CC-Link/LT		–
		FX2N-16LNK-M	0*5	200	0	90	–
	FX2N-32ASI-M	8*6	150	0	70	–	
E3		FX0N-3A	8	30	90*7	0	165

- *1. When the voltage of the external DC power supply is 24V DC and 5V DC, the current is 70 mA and 100 mA, respectively.
- *2. This master cannot be used together with FX2N-16CCL-M and/or FX2N-32ASI-M.
The following number of points is added according to the products connected to the network.
Number of remote I/O stations × 32 points
- *3. This master cannot be used together with FX3U-16CCL-M and/or FX2N-32ASI-M.
The following number of points is added according to the products connected to the network.
Number of remote I/O stations × 32 points
- *4. The following number of points is added according to the products connected to the network.
Total number of input/output points of remote I/O stations
- *5. The number of points varies according to the products connected to the network.
For details, refer to FX2N-16LNK-M Manual.
- *6. This master cannot be used together with FX3U-16CCL-M and/or FX2N-16CCL-M. Only one unit can be added to the whole system.
The following number of points is added according to the products connected to the network.
Number of active slaves × 8 points

- *7. When analog special function blocks (FX_{0N}-3A, FX_{2N}-2AD and FX_{2N}-2DA) are connected to an input/output powered extension unit (FX_{2N}-32E□ or FX_{2N}-48E□), the following limitation must be taken into consideration. (When the blocks are connected to the main unit, this limitation is not applied.)
The total current consumption of the analog special function blocks (FX_{0N}-3A, FX_{2N}-2AD and FX_{2N}-2DA) should be less than the following current values.
- Total current consumption of blocks connected to FX_{2N}-32E□: 190 mA or less
 - Total current consumption of blocks connected to FX_{2N}-48E□: 300 mA or less
- *8. When applying the DC power type main unit, calculate the current consumption at startup.

2. Special function units

No.	Type	Number of input/occupied output points	Current consumed (mA)		
			5V DC	Internal 24V DC	External 24V DC
E3	FX _{2N} -10GM	8	–	–	5
	FX _{2N} -20GM	8	–	–	10
	FX _{2N} -1RM(-E)-SET	8	–	–	5

6.8.6 [G] Display module

–: No need to calculate

No.	Type	Number of input/occupied output points	Current consumed (mA)		
			5V DC	Internal 24V DC	External 24V DC
G1	FX _{3U} -7DM	–	20	0	0

6.8.7 [H] Extension power supply unit

–: No need to calculate

No.	Type	Number of input/occupied output points	Current consumed (mA) ^{*1}	
			5V DC	Internal 24V DC
H1	FX _{3U} -1PSU-5V	–	1000	300

- *1. The ambient temperature restricts the output current. For details, refer to the derating curve in Section 6.7.

6.9 Example of System Configuration and System Modification

The procedures for evaluating the suitability of the system configuration are explained using an example system configuration consisting of an expansion board, special adapters, input/output powered extension units/blocks and special function blocks.

6.9.1 Example system configuration

A system configuration is examined using the following example.

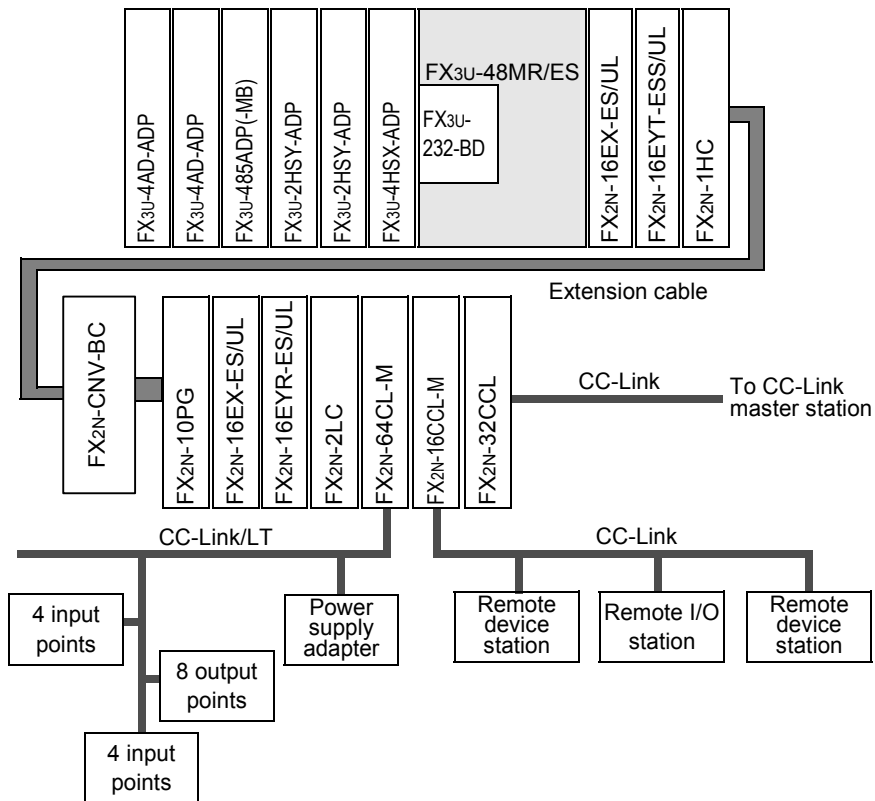

6.9.2 Expansion of main unit

The suitability of the above system configuration is evaluated as shown below.

1 Enter the specifications for the main unit.

	Classification	Number of connected units	Type	Number of input/output points [points]	Capacity of built-in power supply	
					5V DC power supply [mA]	24V DC service power supply [mA]
				1-1	1-2	1-3
With built-in power supply	A Main unit	1	FX3U-48MR/ES	48	500	600

2 Enter the specifications for the products to be connected to the main unit.

	Classification	Number of connected units	Type	Number of input/output (occupied) points [points]	Calculation of current consumption of built-in power supply	
					5V DC power supply [mA]	24V DC power supply [mA]
Enter the products connected to the main unit.	B Expansion board	1	FX3U-232-BD	-	20	0
	C Special adapter	6	FX3U-4HSX-ADP	-	30	30
			FX3U-2HSY-ADP	-	30	60
			FX3U-2HSY-ADP	-	30	60
			FX3U-485ADP(-MB)	-	20	0
			FX3U-4AD-ADP	-	15	0
			FX3U-4AD-ADP	-	15	0
	D2 Input/output extension block	4	FX2N-16EX-ES/UL	16	-	100
			FX2N-16EYT-ESS/UL	16	-	150
			FX2N-16EX-ES/UL	16	-	100
			FX2N-16EYR-ES/UL	16	-	150
	E Special function unit/block	6	FX2N-1HC	8	90	0
			FX2N-10PG	8	120	0
			FX2N-2LC	8	70	0
			FX2N-64CL-M	8+16 ^{*1}	190	0
			FX2N-16CCL-M	8	0	0
			FX2N-32CCL	8	130	0
				2-1	2-2	2-3
Calculate the totals.				128	760	650

*1. The number for FX2N-64CL-M is calculated by adding the number of input/output points at the connected remote I/O station to 8 points.

1	Introduction
2	Features and Part Names
3	Product Introduction
4	Specifications
5	Version and Peripheral Devices
6	System Configuration
7	Input/Output Nos., Unit Nos.
8	Installation
9	Preparation and Power Supply Wiring
10	Input Wiring

3 Calculate the number of input/output points.

Calculate the number of input/output points on the whole system.

1. Calculate the number of input/output points of the main unit and extension devices.

Number of input/output points			
Main unit	Total input/output points of extension devices	Calculation result	Max. number of input/output points
<div style="border: 1px solid black; padding: 2px; display: inline-block;">1-1</div> 48 points	<div style="border: 1px solid black; padding: 2px; display: inline-block;">2-1</div> 128 points	<div style="border: 1px solid black; padding: 2px; display: inline-block;">A</div> 176 points	≤ 256 points OK

2. Calculate the number of remote I/O points on the network.

Since this system uses CC-Link, calculate the number of the remote I/O stations.

Input/output on network	Calculation result	Max. number of input/output points
Number of CC-Link remote I/O stations <div style="border: 1px solid black; padding: 2px; display: inline-block; width: 100px; height: 30px; margin: 5px auto;">1 station</div>	$\times 32 \text{ points} =$ <div style="border: 1px solid black; padding: 2px; display: inline-block; width: 100px; height: 30px; margin: 5px auto;">B</div> 32 points	$\leq 224 \text{ points}$ OK
<div style="display: flex; align-items: center;"> <div style="border-left: 1px solid black; border-bottom: 1px solid black; width: 100px; height: 15px; margin-right: 5px;"></div> <div style="font-size: 0.8em;">FX2N-16CCL-M: up to 7 stations</div> </div>		

3. Calculate the total number of input/output occupied points (number of input/output points).

Total number of input/output points		Calculation result	Max. number of input/output points
Number of input/output occupied points <div style="border: 1px solid black; padding: 2px; display: inline-block; width: 100px; height: 30px; margin: 5px auto;">A</div> 176 points <small>Total obtained in Step 1</small>	$+$ Input/output on network <div style="border: 1px solid black; padding: 2px; display: inline-block; width: 100px; height: 30px; margin: 5px auto;">B</div> 32 points <small>Total obtained in Step 2</small>	$=$ <div style="border: 1px solid black; padding: 2px; display: inline-block; width: 100px; height: 30px; margin: 5px auto;">208 points</div>	$\leq 384 \text{ points}$ OK

4 Determine whether the devices can be added to the main unit.

Calculate the current consumption to confirm whether the extension devices selected in the above step can be connected.

4. Calculate the current consumption of the built-in 5V DC power supply.

Capacity of 5V DC power supply	Current consumption	Calculation result
Main unit	Total of current consumed by extension devices	
1-2 500mA	2-2 760mA	= -260mA

NG

5. Calculate the current consumption of the built-in 24V DC power supply (24V DC service power supply).

The value obtained by this calculation (when the value is positive) indicates the remaining capacity of the 24V DC service power supply, that can be used for external loads.

Capacity of 24V DC power supply	Current consumption	Calculation result
Main unit	Total of current consumed by extension devices	
1-3 600mA	2-3 650mA	= -50mA

NG

Since the calculated values of the current consumption of the 5V DC and 24V DC power supplies are negative, it is necessary to reexamine the configuration.

The next subsection explains the procedures for evaluating a reexamined and modified configuration.

1	Introduction
2	Features and Part Names
3	Product Introduction
4	Specifications
5	Version and Peripheral Devices
6	System Configuration
7	Input/Output Nos., Unit Nos.
8	Installation
9	Preparation and Power Supply Wiring
10	Input Wiring

6.9.3 Re-examination of suitability for configuration

When the main unit is short of 5V DC or 24V DC current, use an input/output powered extension unit.
 Reexamine the system configuration using an input/output powered extension unit.

Example of reexamined system configuration

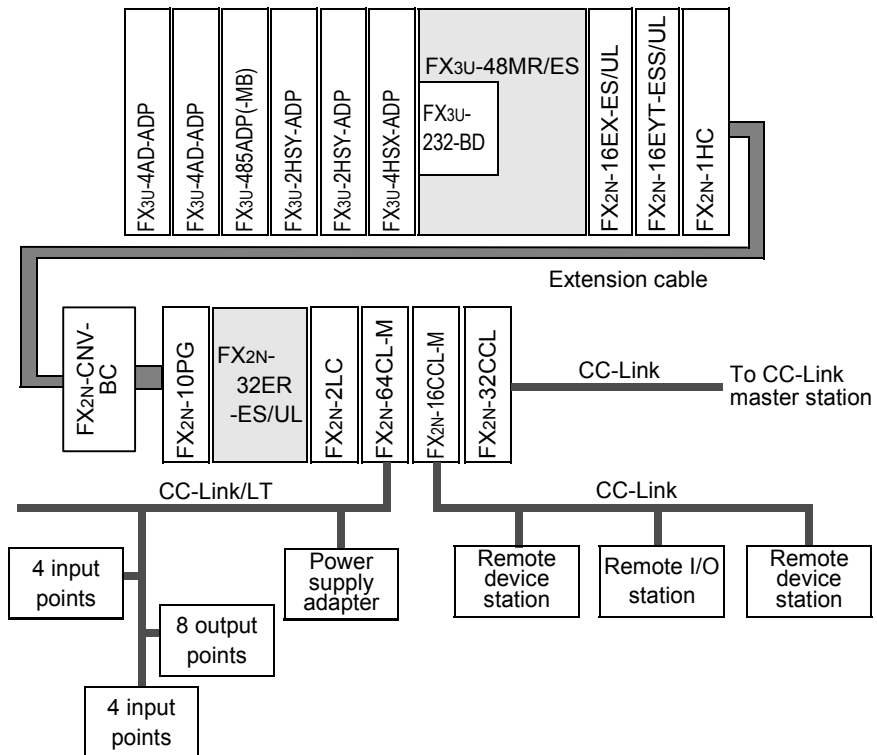

1 Enter the specifications for the main unit.

	Classification	Number of connected units	Type	Number of input/output points [points]	Capacity of built-in power supply	
					5V DC power supply [mA]	24V DC service power supply [mA]
				1-1	1-2	1-3
With built-in power supply	A Main unit	1	FX3U-48MR/ES	48	500	600

2 Enter the specifications for the products to be added to the main unit.

	Classification	Number of connected units	Type	Number of input/output (occupied) points [points]	Calculation of current consumption of built-in power supply	
					5V DC power supply [mA]	Internal 24V DC power supply [mA]
Enter the products connected to the main unit.	B Expansion board	1	FX3U-232-BD	–	20	0
	C Special adapter	6	FX3U-4HSX-ADP	–	30	30
			FX3U-2HSY-ADP	–	30	60
			FX3U-2HSY-ADP	–	30	60
			FX3U-485ADP(-MB)	–	20	0
			FX3U-4AD-ADP	–	15	0
			FX3U-4AD-ADP	–	15	0
	D2 Input/output extension block	2	FX2N-16EX-ES/UL	16	–	100
			FX2N-16EYT-ESS/UL	16	–	150
	E Special function unit/block	2	FX2N-1HC	8	90	0
FX2N-10PG			8	120	0	
				2-1	2-2	2-3
Calculate the totals.				48	370	400

3 Enter the specifications for the input/output powered extension unit.

Power supply classification	Classification	Number of connected units	Type	Number of input/output points [points]	Capacity of built-in power supply	
					5V DC power supply [mA]	24V DC service power supply [mA]
				3-1	3-2	3-3
With built-in power supply	D1 Input/output powered extension unit	1	FX2N-32ER-ES/UL	32	690	250

4 Enter the specifications for the products to be added to the input/output powered extension unit.

	Classification	Number of connected units	Type	Number of input/output occupied points [points]	Calculation of current consumption of built-in power supply	
					5V DC power supply [mA]	Internal 24V DC power supply [mA]
Enter the products connected to the Input/output powered extension unit	E Special function unit/block	4	FX2N-2LC	8	70	0
			FX2N-64CL-M	8+16*1	190	0
			FX2N-16CCL-M	8	0	0
			FX2N-32CCL	8	130	0
				4-1	4-2	4-3
Calculate the totals				48	390	0

*1. The number for FX2N-64CL-M is calculated by adding the number of input/output points at the connected remote I/O station to 8 points.

5 Calculate the number of input/output points.

Calculate the number of input/output points on the whole system.

1. Calculate the number of input/output points of the main unit and extension devices.

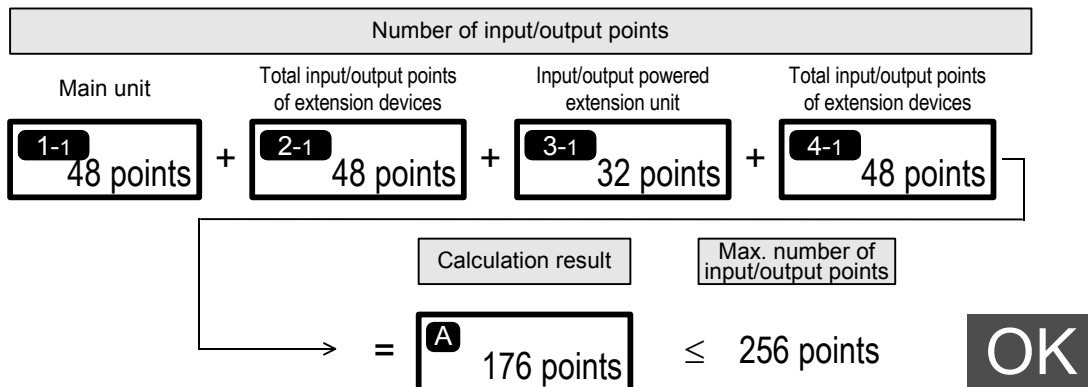

2. Calculate the number of remote I/O points on the network.

Since this system uses CC-Link, calculate the number of the remote I/O stations.

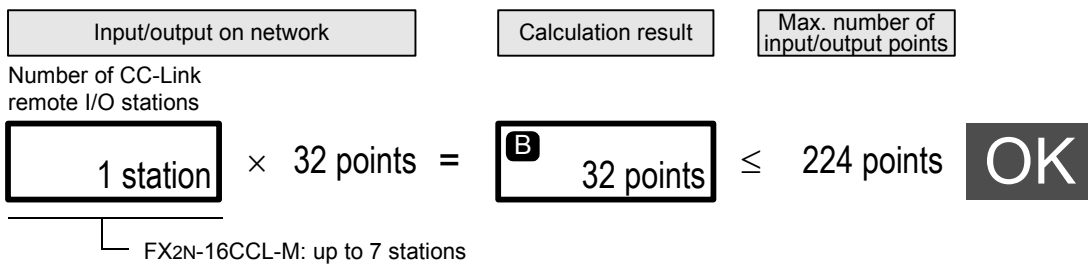

3. Calculate the total number of input/output occupied points (number of input/output points).

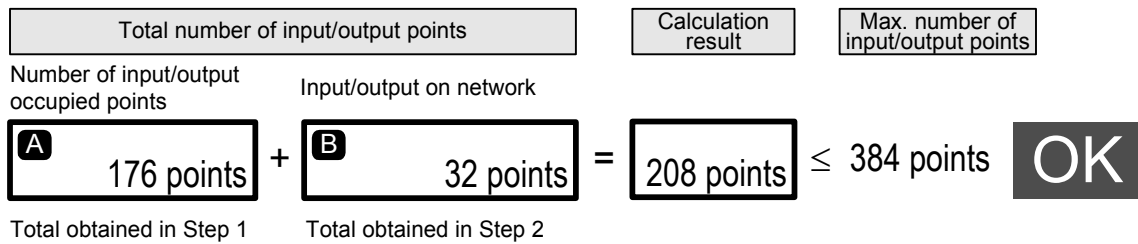

6 Determine whether the devices can be added to the main unit.

Calculate the current by the following formula to confirm whether the extension devices selected in Step 2 can be connected.

1. Calculate the current consumption of the built-in 5V DC power supply.

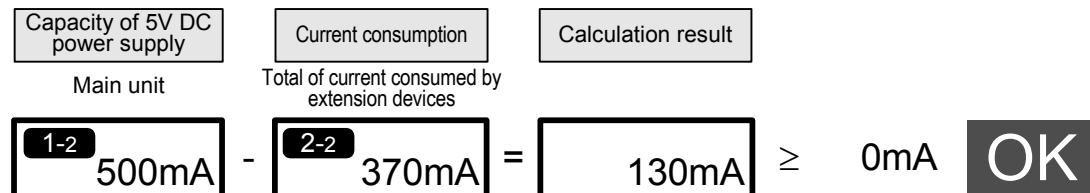

2. Calculate the current consumption of the built-in 24V DC power supply (24V DC service power supply).

The value obtained by this calculation (when the value is positive) indicates the remaining capacity of the 24V DC service power supply, that can be used for external loads.

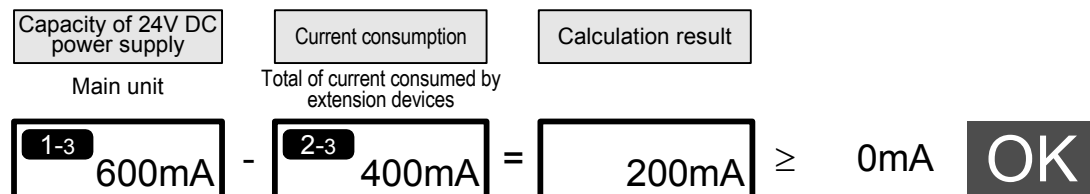

1 Introduction

2 Features and Part Names

3 Product Introduction

4 Specifications

5 Version and Peripheral Devices

6 System Configuration

7 Input/Output Nos., Unit Nos.

8 Installation

9 Preparation and Power Supply Wiring

10 Input Wiring

7 Determine whether the devices can be connected to the input/output powered extension unit.

Calculate the current by the following formula to confirm whether the extension devices selected in Step 4 can be connected.

1. Calculate the current consumption of the built-in 5V DC power supply.

Capacity of 5V DC power supply Input/output powered extension unit	Current consumption Total of current consumed by extension devices	Calculation result
3-2 690mA	4-2 390mA	300mA

$$690\text{mA} - 390\text{mA} = 300\text{mA} \geq 0\text{mA} \quad \text{OK}$$

2. Calculate the current consumption of the built-in 24V DC power supply (24V DC service power supply).

The value obtained by this calculation (when the value is positive) indicates the remaining capacity of 24V DC service power supply, and the capacity can be used for external loads

Capacity of 24V DC power supply Input/output powered extension unit	Current consumption Total of current consumed by extension devices	Calculation result
3-3 250mA	4-3 0mA	250mA

$$250\text{mA} - 0\text{mA} = 250\text{mA} \geq 0\text{mA} \quad \text{OK}$$

8 Verify the evaluation results.

Since the capacities of the 5V DC and 24V DC power supplies and the number of input/output points are within the specified ranges, the reexamined system configuration is feasible.

1	Introduction
2	Features and Part Names
3	Product Introduction
4	Specifications
5	Version and Peripheral Devices
6	System Configuration
7	Input/Output Nos., Unit Nos.
8	Installation
9	Preparation and Power Supply Wiring
10	Input Wiring

7. Assignment of Input/Output Numbers (X/Y) and Unit Numbers

7.1 Assignment of Input/Output Numbers (X/Y)

If input/output powered extension units/blocks have been connected when the power is turned on, the main unit automatically assigns the input/output numbers (X/Y) (octal) to the units/blocks.

Therefore, it is unnecessary to specify the input/output numbers with parameters.

Accordingly, it is not necessary to specify input/output numbers using parameters.

It is necessary to assign input and output numbers in the following special extension unit/block:

- FX2N-64CL-M
- FX2N-16LNK-M

7.1.1 Concept of assigning

When the power is turned on, input/output numbers (X/Y) are assigned according to the following rules. For special function blocks, such as FX2N-64CL-M and FX2N-16LNK-M, that assign input/output numbers to connected remote I/O stations, refer to the manual for each block.

1. Input/output numbers (X/Y) are octal.

Octal numbers are assigned as input/output numbers (X/Y) as shown below.

- X000 to X007, X010 to X017, X020 to X027....., X070 to X077, X100 to 107...
- Y000 to Y007, Y010 to Y017, Y020 to Y027....., Y070 to Y077, Y100 to Y107...

2. Numbers for added input/output unit/block

To an added input/output powered extension unit/block, input numbers and output numbers following the input numbers and output numbers given to the preceding device are assigned.

The last digit of the assigned numbers must begin with 0.

For example, when the last number on the preceding device is X043, the input numbers are assigned to the next device starting from X050.

(When the FX2N-8ER is used, some input/output numbers are not used.)

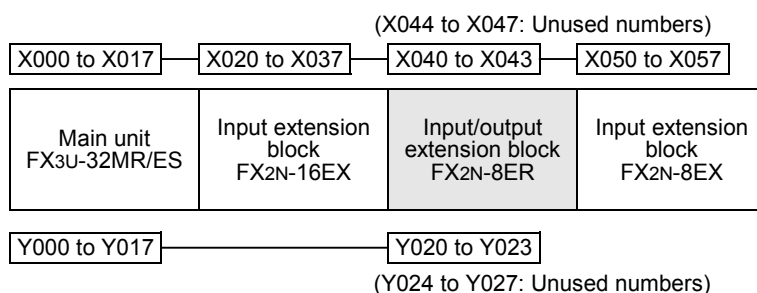

7.1.2 Example of assigning

An example of assignment of input/output numbers (X/Y) is shown below.

1. Example of configuration

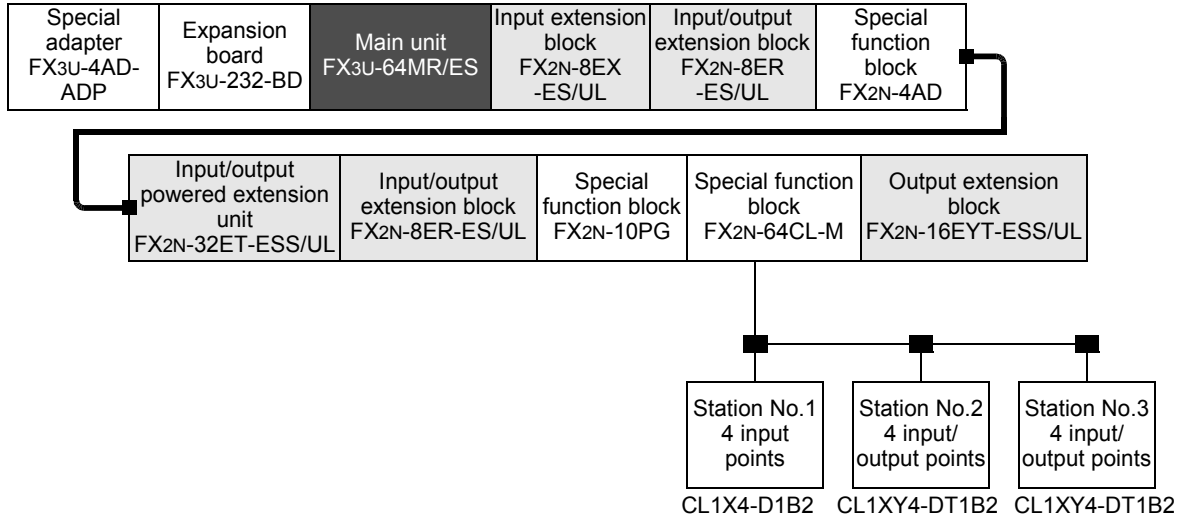

2. Assignment of input/output numbers

Input/output numbers are assigned to the above example configuration as shown below.

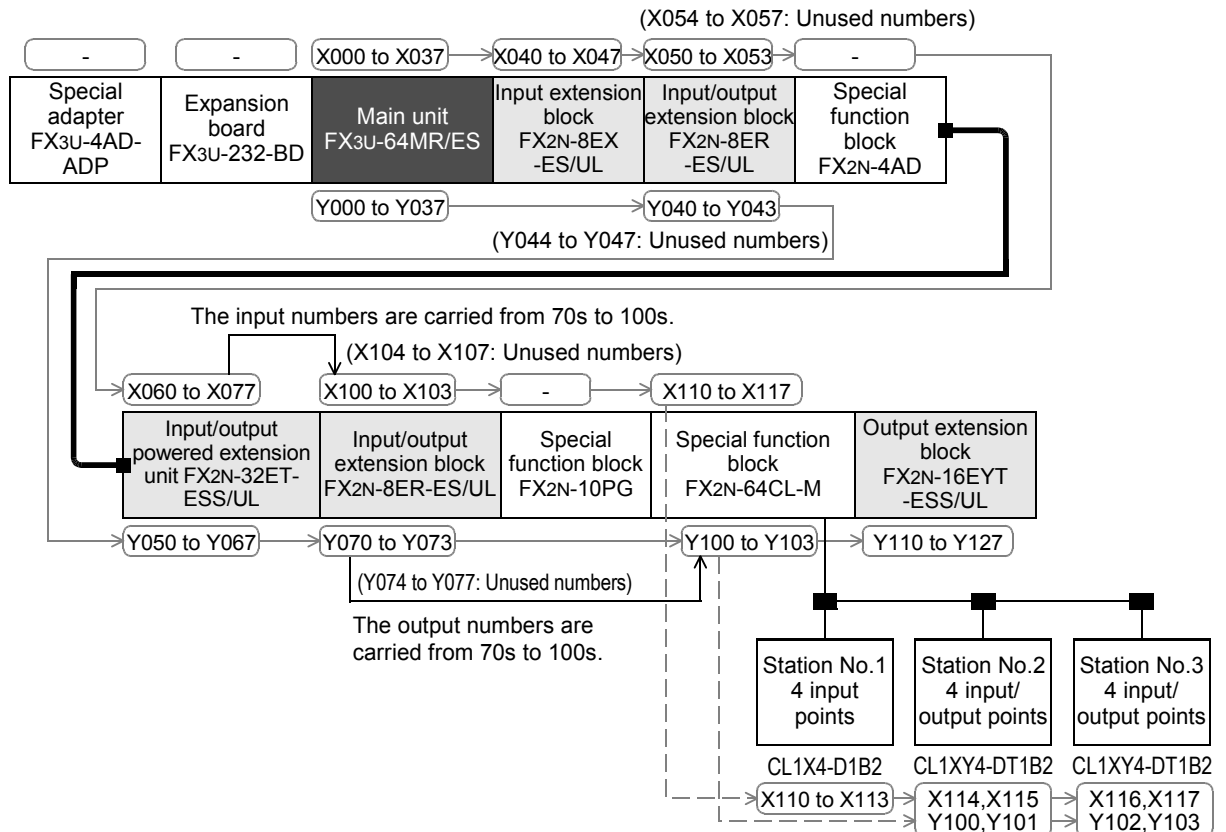

7.1.3 Application of I/O number label

The input/output powered extension units/blocks come with an I/O number label.
 Apply the I/O number label to spaces on the enclosure (see the following figure) so that the input/output numbers can be identified.

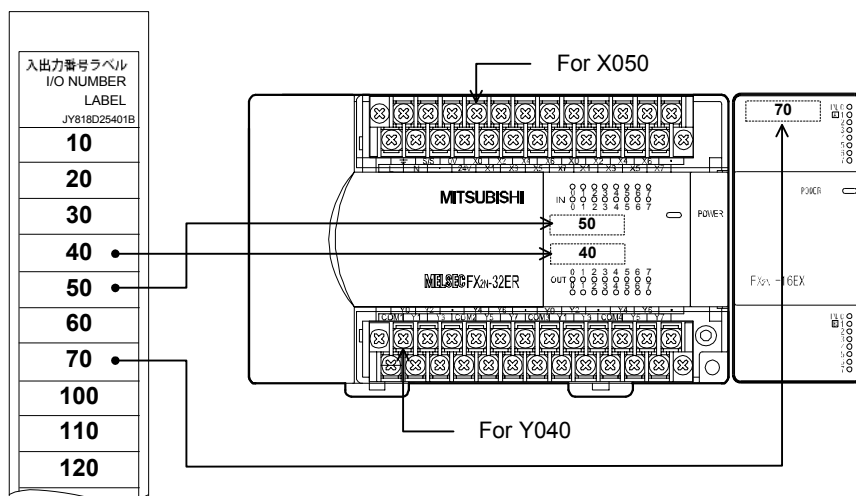

1	Introduction
2	Features and Part Names
3	Product Introduction
4	Specifications
5	Version and Peripheral Devices
6	System Configuration
7	Input/Output Nos., Unit Nos.
8	Installation
9	Preparation and Power Supply Wiring
10	Input Wiring

7.2 Unit Numbers of Special Function Units/Blocks

7.2.1 Concept of assigning

When power is turned on, the main unit (CPU) automatically assigns the numbers 0 to 7 to special function units/blocks starting from the one closest to the main unit.

Unit numbers are not given to input/output powered extension units/blocks.

1. Special function units/blocks connected to main unit

The numbers 0 to 7 are assigned to the special function units/blocks starting from the one closest to the main unit.

2. FX2N-1RM(-E)-SET

Up to three FX2N-1RM(-E)-SET can be sequentially connected to the end of one system.

All these connected units have the same number as the unit number of the first unit (FX2N-1RM(-E)-SET).

→ For FX2N-1RM-E-SET, refer to FX2N-1RM-E-SET USER'S MANUAL.

3. Products to which unit numbers are not assigned

- Input/output powered extension units: FX2N-32ER-ES/UL, FX2N-48ET-ESS/UL, etc.
- Input/output extension blocks: FX2N-16EX-ES/UL, FX2N-16EYR-ES/UL, etc.
- Special function block: FX2N-16LNK-M
- Connector conversion adapter: FX2N-CNV-BC
- Expansion boards: FX3U-232-BD, etc.
- Special adapters: FX3U-232ADP, etc.
- Extension power supply unit: FX3U-1PSU-5V

7.2.2 Example of assigning

Unit numbers are assigned to the special function units/blocks in the following configuration.

→ For assignment of input/output numbers, refer to Section 7.1.

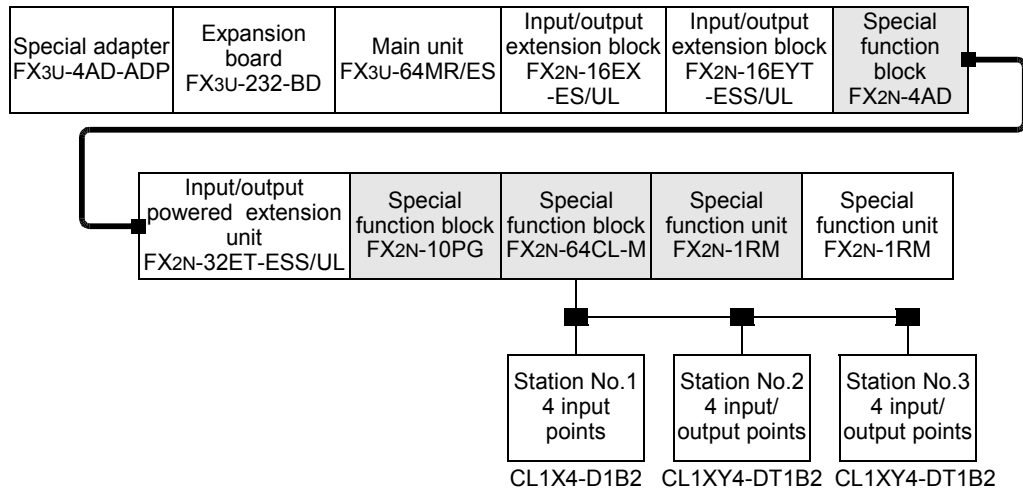

Unit numbers are assigned to the special function units/blocks in the above configuration as shown below.

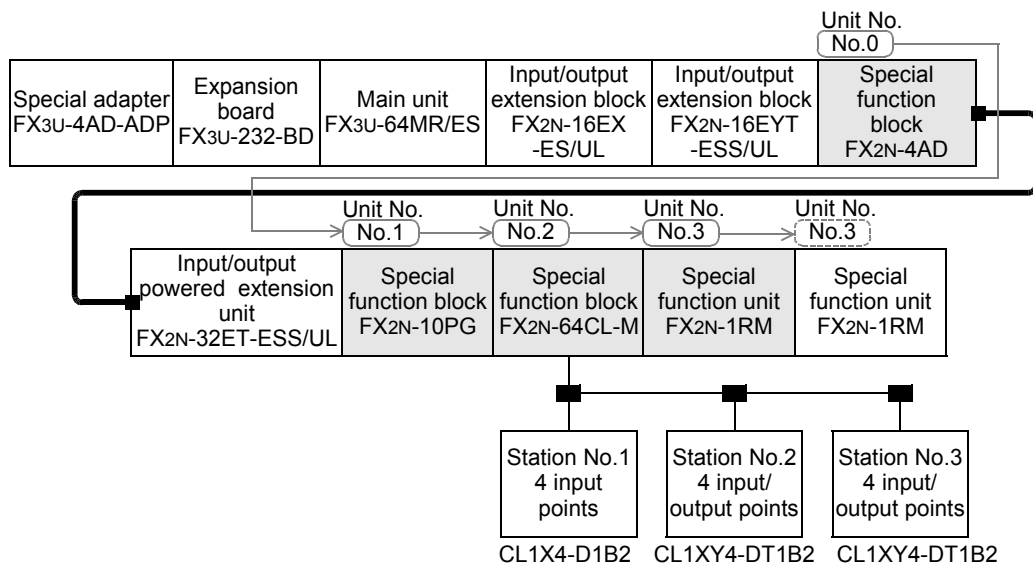

1	Introduction
2	Features and Part Names
3	Product Introduction
4	Specifications
5	Version and Peripheral Devices
6	System Configuration
7	Input/Output Nos., Unit Nos.
8	Installation
9	Preparation and Power Supply Wiring
10	Input Wiring

7.2.3 Application of unit number labels

The special function units/blocks come with unit number labels. Apply the unit number labels to spaces on the enclosure (see the following figure) so that the unit numbers can be identified.

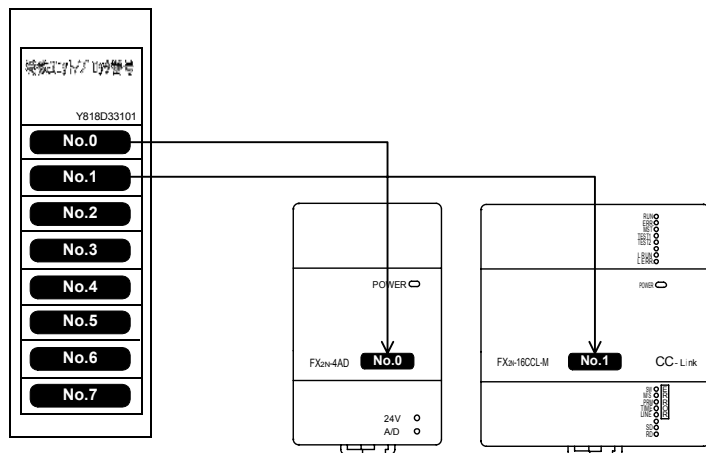

7.3 Application of the trimmer layout label

The analog volume expansion board (FX3U-8AV-BD) comes with a trimmer layout label. Apply the trimmer layout label in a position (see the following figure) so that the each trimmer can be identified.

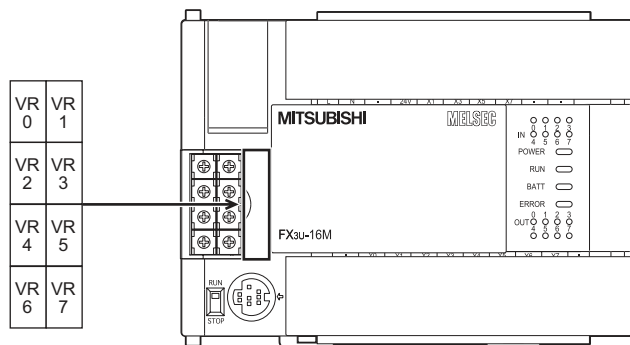

8. Installation In Enclosure

DESIGN PRECAUTIONS



- Make sure to have the following safety circuits outside of the PLC to ensure safe system operation even during external power supply problems or PLC failure. Otherwise, malfunctions may cause serious accidents.
 - 1) Most importantly, have the following: an emergency stop circuit, a protection circuit, an interlock circuit for opposite movements (such as normal vs. reverse rotation), and an interlock circuit (to prevent damage to the equipment at the upper and lower positioning limits).
 - 2) Note that when the PLC CPU detects an error, such as a watchdog timer error, during self-diagnosis, all outputs are turned off. Also, when an error that cannot be detected by the PLC CPU occurs in an input/output control block, output control may be disabled. External circuits and mechanisms should be designed to ensure safe machinery operation in such a case.
 - 3) Note that the output current of the 24V DC service power supply varies depending on the model and the absence/presence of extension blocks. If an overload occurs, the voltage automatically drops, inputs in the PLC are disabled, and all outputs are turned off. External circuits and mechanisms should be designed to ensure safe machinery operation in such a case.
 - 4) Note that when an error occurs in a relay, triac or transistor output device, the output could be held either on or off. For output signals that may lead to serious accidents, external circuits and mechanisms should be designed to ensure safe machinery operation in such a case.

DESIGN PRECAUTIONS



- Do not bundle the control line together with or lay it close to the main circuit or power line. As a guideline, lay the control line at least 100mm (3.94") or more away from the main circuit or power line. Noise may cause malfunctions.
- Install module so that excessive force will not be applied to peripheral device connectors. Failure to do so may result in wire damage/breakage or PLC failure.

INSTALLATION PRECAUTIONS



- Make sure to cut off all phases of the power supply externally before attempting installation or wiring work. Failure to do so may cause electric shock or damage to the product.

1

Introduction

2

Features and
Part Names

3

Product
Introduction

4

Specifications

5

Version and
Peripheral
Devices

6

System
Configuration

7

Input/Output
Nos., Unit Nos.

8

Installation

9

Preparation and
Power Supply
Wiring

10

Input Wiring

INSTALLATION PRECAUTIONS



- Use the product within the generic environment specifications described in section 4.1 of this manual. Never use the product in areas with excessive dust, oily smoke, conductive dusts, corrosive gas (salt air, Cl₂, H₂S, SO₂ or NO₂), flammable gas, vibration or impacts, or expose it to high temperature, condensation, or rain and wind. If the product is used in such conditions, electric shock, fire, malfunctions, deterioration or damage may occur.
- Do not touch the conductive parts of the product directly. Doing so may cause device failures or malfunctions.
- Install the product securely using a DIN rail or mounting screws.

FX2N-10GM, FX2N-20GM, and terminal block	DIN rail only
Main unit, FX2N Series I/O extension unit/block, and FX0N/FX2N/FX3U Series special extension block/special adapter	DIN rail or direct mounting

- Install the product on a flat surface. If the mounting surface is rough, undue force will be applied to the PC board, thereby causing nonconformities.
- Make sure to affix the expansion board with tapping screws. Tightening torque should follow the specifications in the manual. Loose connections may cause malfunctions.
- When drilling screw holes or wiring, make sure that cutting and wiring debris do not enter the ventilation slits. Failure to do so may cause fire, equipment failures or malfunctions.
- Be sure to remove the dust proof sheet from the PLC's ventilation port when installation work is completed. Failure to do so may cause fire, equipment failures or malfunctions.
- Connect the extension cables, peripheral device cables, input/output cables and battery connecting cable securely to their designated connectors. Loose connections may cause malfunctions.
- Connect the display module, memory cassette, and expansion board securely to their designated connectors. Loose connections may cause malfunctions.
- Turn off the power to the PLC before attaching or detaching the following devices. Failure to do so may cause device failures or malfunctions.
 - Peripheral devices, display modules, expansion boards and special adapters
 - Extension units/blocks and FX Series terminal blocks
 - Battery and memory cassette

WIRING PRECAUTIONS



- Make sure to cut off all phases of the power supply externally before attempting installation or wiring work. Failure to do so may cause electric shock or damage to the product.
- Make sure to attach the terminal cover, offered as an accessory, before turning on the power or initiating operation after installation or wiring work. Failure to do so may cause electric shock.

WIRING PRECAUTIONS



- Do not supply power to the [24+] and [24V] terminals (24V DC service power supply) on the main unit or extension units.
Doing so may cause damage to the product.
- Perform class D grounding (grounding resistance: 100 Ω or less) to the grounding terminal on the main unit and extension units with a wire 2 mm² or thicker.
Do not use common grounding with heavy electrical systems (refer to Section 9.4).
- Connect the AC power supply wiring to the dedicated terminals described in this manual.
If an AC power supply is connected to a DC input/output terminal or DC power supply terminal, the PLC will burn out.
- Connect the DC power supply wiring to the dedicated terminals described in this manual.
If an AC power supply is connected to a DC input/output terminal or DC power supply terminal, the PLC will burn out.
- Do not wire vacant terminals externally.
Doing so may damage the product.
- When drilling screw holes or wiring, make sure that cutting and wiring debris do not enter the ventilation slits.
Failure to do so may cause fire, equipment failures or malfunctions.
- Make sure to properly wire the FX3U Series main unit and FX0N/FX2N/FX3U Series extension equipment in accordance with the following precautions.
Failure to do so may cause electric shock, equipment failures, a short-circuit, wire breakage, malfunctions, or damage to the product.
 - The disposal size of the cable end should follow the dimensions described in the manual.
 - Tightening torque should follow the specifications in the manual.
- Make sure to properly wire to the terminal block (European type) in accordance with the following precautions.
Failure to do so may cause electric shock, equipment failures, a short-circuit, wire breakage, malfunctions, or damage to the product.
 - The disposal size of the cable end should follow the dimensions described in the manual.
 - Tightening torque should follow the specifications in the manual.
 - Twist the end of strand wire and make sure that there are no loose wires.
 - Do not solder-plate the electric wire ends.
 - Do not connect more than the specified number of wires or electric wires of unspecified size.
 - Affix the electric wires so that neither the terminal block nor the connected parts are directly stressed.
- Make sure to properly wire to the FX Series terminal blocks in accordance with the following precautions.
Failure to do so may cause electric shock, equipment failures, a short-circuit, wire breakage, malfunctions, or damage to the product.
 - The disposal size of the cable end should follow the dimensions described in the manual.
 - Tightening torque should follow the specifications in the manual.

This chapter explains the procedures for installing the PLC in enclosure.

The procedures for wiring the input and output terminals are described in the following chapters.

- Installation location and layout in enclosure
- Procedures for connecting extension devices
- Procedures for power supply wiring

1

Introduction

2

Features and
Part Names

3

Product
Introduction

4

Specifications

5

Version and
Peripheral
Devices

6

System
Configuration

7

Input/Output
Nos., Unit Nos.

8

Installation

9

Preparation and
Power Supply
Wiring

10

Input Wiring

8.1 Generic Specifications

Item	Specification				
Ambient temperature	0 to 55°C (32 to 131°F) when operating and -25 to 75°C (-13 to 167°F) when stored				
Ambient humidity	5 to 95%RH (no condensation) when operating				
Vibration resistance*1	When installed on DIN rail	Frequency (Hz)	Acceleration (m/s ²)	Half amplitude (mm)	Sweep Count for X, Y, Z: 10 times (80 min in each direction)
		10 to 57	–	0.035	
	When installed directly	57 to 150	4.9	–	
		10 to 57	–	0.075	
57 to 150	9.8	–			
Shock resistance*1	147 m/s ² Acceleration, Action time: 11ms, 3 times by half-sine pulse in each direction X, Y, and Z				
Noise resistance	By noise simulator at noise voltage of 1,000 Vp-p, noise width of 1 μs, rise time of 1 ns and period of 30 to 100 Hz				
Dielectric withstand voltage*3	1.5kV AC for one minute	Between each terminals and ground terminal			
	500V AC for one minute				
Insulation resistance*3	5MΩ or more by 500V DC megger				
Grounding	Class D grounding (grounding resistance: 100 Ω or less) <Common grounding with a heavy electrical system is not allowed.>*2				
Working atmosphere	Free from corrosive or flammable gas and excessive conductive dusts				
Working altitude	<2000m*4				

*1. The criterion is shown in IEC61131-2.

*2. Ground the PLC independently or jointly.

→ Refer to Section 9.4.

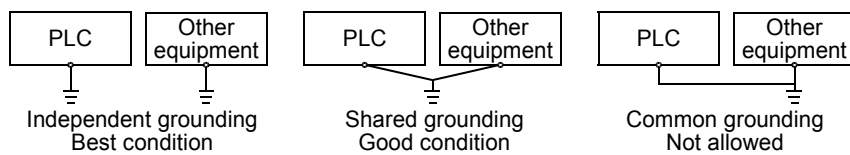

*3. For more information on the dielectric withstand voltage test and the insulation resistance test of the terminals of each product, refer to the following subsection.

→ Refer to Subsection 4.1.1.

*4. Do not use the PLC under pressure higher than the atmospheric pressure. Doing so may damage the PLC.

8.2 Installation location

Use the PLC under the environmental conditions complying with the generic specifications (Section 8.1).

Notes
<ul style="list-style-type: none">• Keep a space of 50 mm (1.97") away between the unit main body and other devices and structure. Install the unit as far away as possible from high-voltage lines, high-voltage devices and power equipment.• To prevent temperature rise, do not install the PLC on a floor or a ceiling or in the vertical direction. Install it horizontally on a wall as shown below.• Arrange the extension cable in such a way that the left connectors of the input/output powered extension units/blocks or special function units/blocks are connected on the side closer to the main unit.

8.2.1 Installation location in enclosure

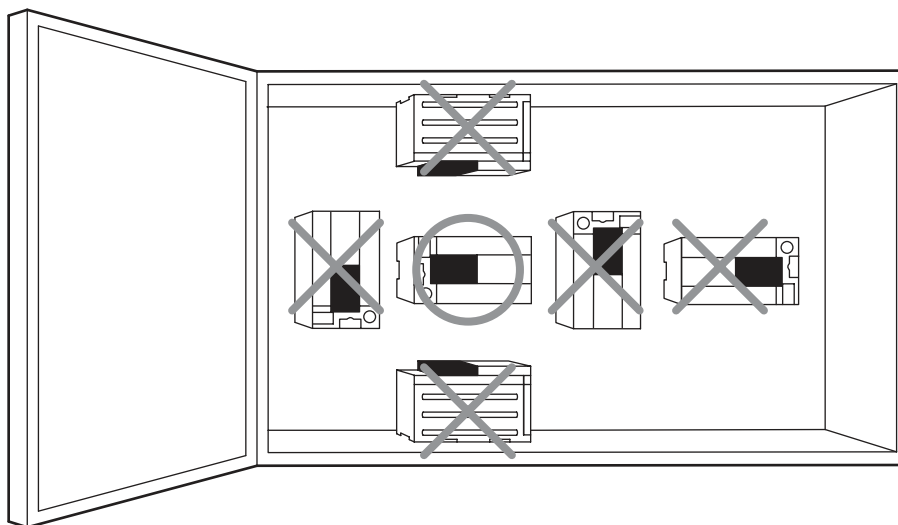

1

Introduction

2

Features and
Part Names

3

Product
Introduction

4

Specifications

5

Version and
Peripheral
Devices

6

System
Configuration

7

Input/Output
Nos., Unit Nos.

8

Installation

9

Preparation and
Power Supply
Wiring

10

Input Wiring

8.2.2 Spaces in enclosure

Extension devices can be connected on the left and right sides of the main unit of the PLC.
 If you intend to add extension devices, keep necessary spaces on the left and right sides.

1. Configuration without extension cable

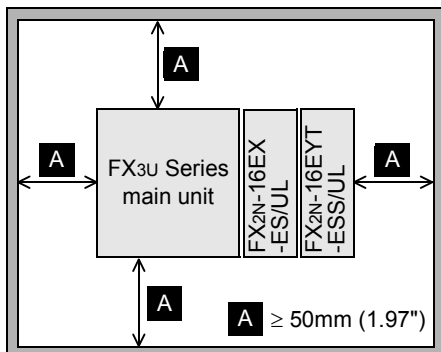

2. Configuration in 2 stages with extension cable

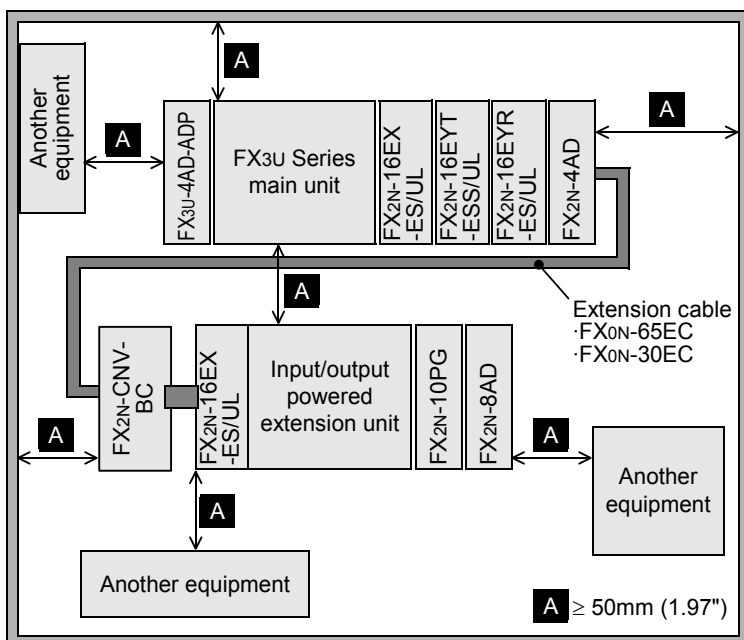

8.3 Layout in Enclosure

The PLC components can be laid out in one stage or in two stages, upper and lower. The connecting procedures in each case are explained below.

8.3.1 1-stage layout

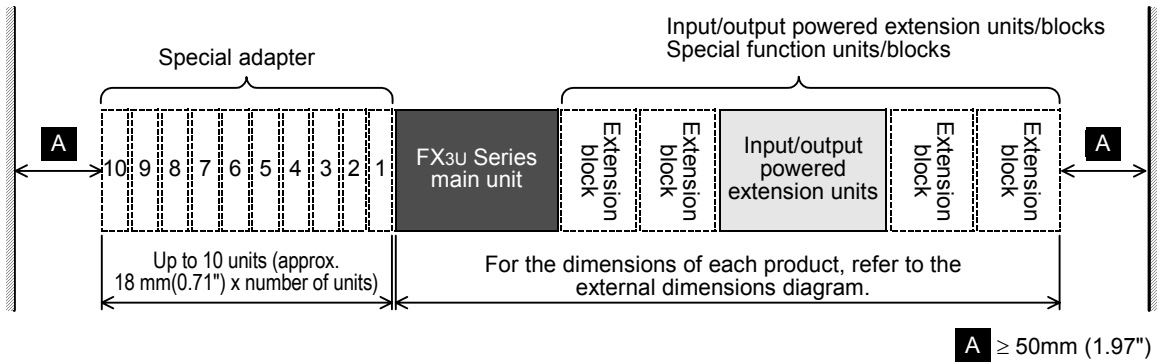

8.3.2 2-stage layout

In case of a 2-stage layout, connect the first stage and the second stage with the extension cable. When an extension block is connected at the top of the second stage, FX2N-CNV-BC (connector conversion adapter) is necessary.

1. When an input/output powered extension unit is connected at the top of the 2nd stage

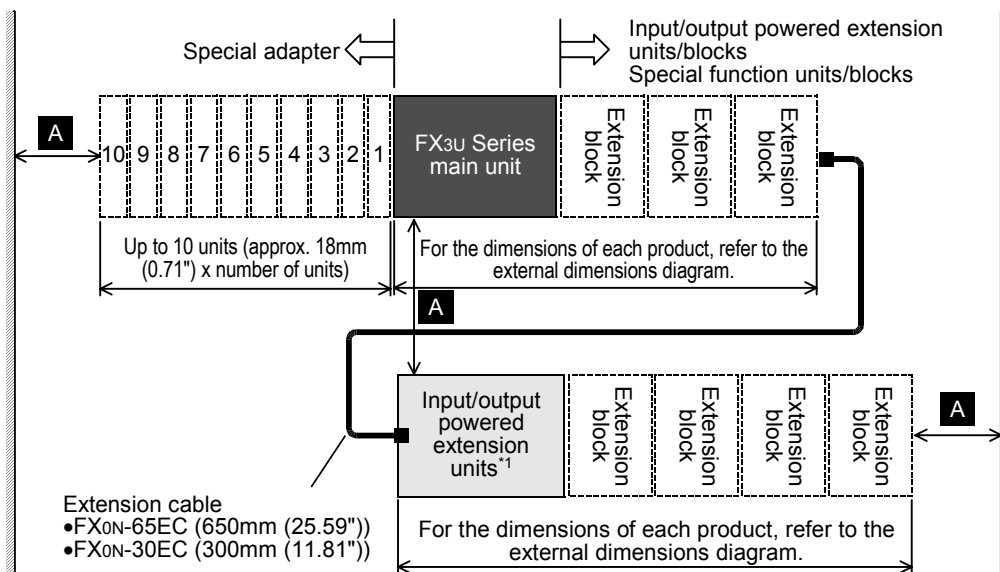

*1 The shaded part in the above figure includes FX2N-1RM(-E)-SET and FX3U-1PSU-5V, however only FX2N-1RM(-E)-SET is connectable to FX2N-1RM(-E)-SET.

$A \geq 50\text{mm (1.97")}$

1	Introduction
2	Features and Part Names
3	Product Introduction
4	Specifications
5	Version and Peripheral Devices
6	System Configuration
7	Input/Output Nos., Unit Nos.
8	Installation
9	Preparation and Power Supply Wiring
10	Input Wiring

2. When an input/output extension block or a special function block is connected at the top of the 2nd stage

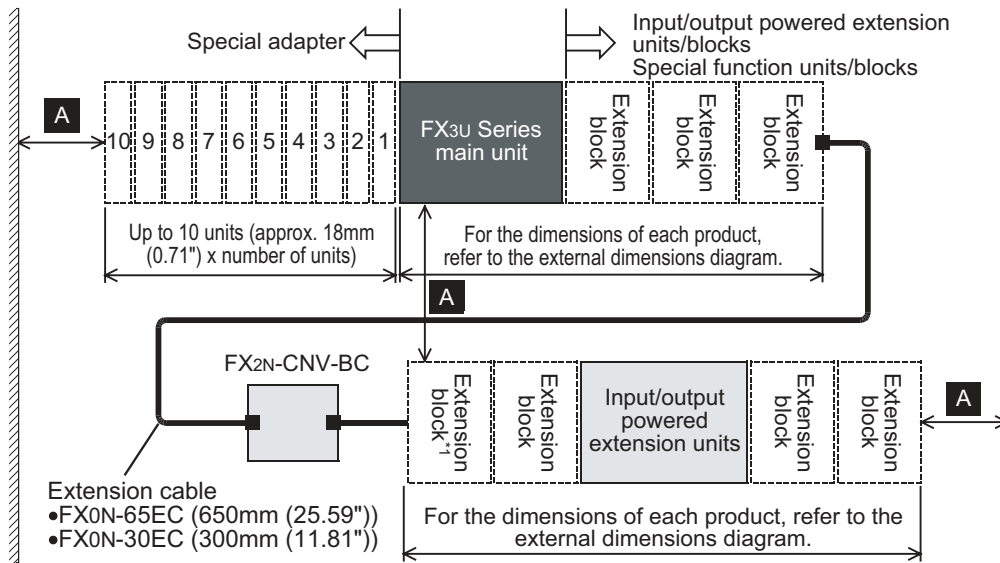

*1 Except for the FX3U-4LC or FX2N-8AD

A ≥ 50mm (1.97")

3. When a special function block (FX2N-10GM/20GM) is connected at the 2nd stage

→ Refer to the previous page for FX2N-1RM(-E)-SET information.

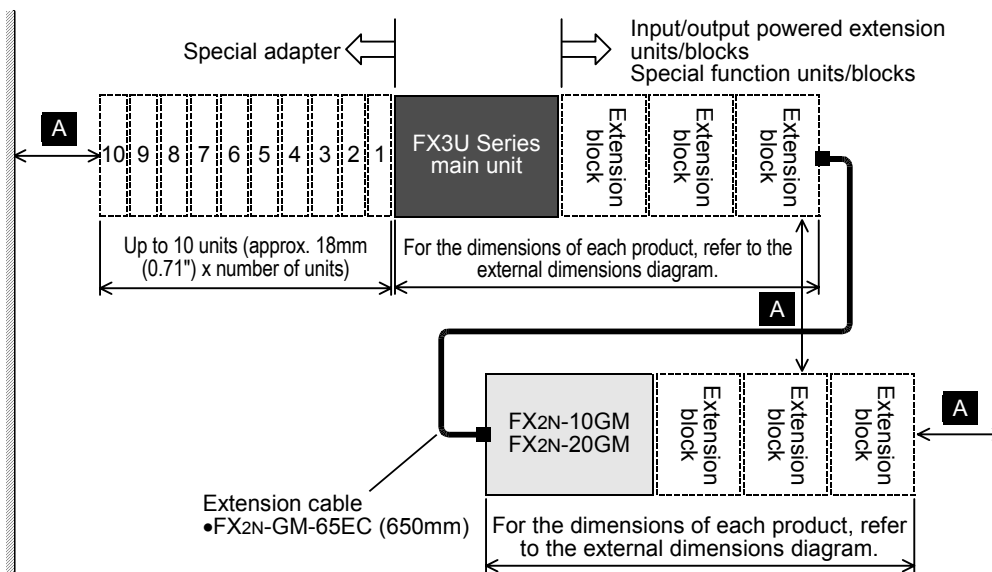

A ≥ 50mm (1.97")

8.4 Examination for Installing Method in Enclosure

Examine the installation location of PLC in consideration of the environmental conditions (generic specifications).

8.4.1 Installing methods

The PLC can be installed by the following two methods.

1. Installing on DIN rail

- The PLC can be installed on a 35 mm (1.38") wide DIN46277 rail.
- The PLC can be easily moved and removed.
- The PLC is installed higher by the height of the DIN rail.
→ For details on the procedures on mounting and removing the DIN rail, refer to Section 8.5.

2. Direct installing (with screws)

- The PLC can be installed directly in the enclosure with M4 screws.
→ For the mounting hole pitch, refer to Section 8.6.

8.4.2 Cautions on examining installing method

→ Refer to Section 8.3.

1. Cautions when FX3U-4LC or FX2N-8AD is used

When the system is laid out in two stages, do not mount the FX3U-4LC or FX2N-8AD at the start of the second stage, or else the FX2N-CNV-BC cannot be secured properly.

2. Cautions when FX2N-10GM or FX2N-20GM is used

FX2N-10GM and FX2N-20GM can be installed only on the DIN rail.
They cannot be installed directly in the enclosure.

8.4.3 Examples of installation

As shown in the following example, when the main unit is installed on the DIN rail, the extension devices connected with the extension cable can be installed directly in the enclosure.

1. Example of installation on DIN rail

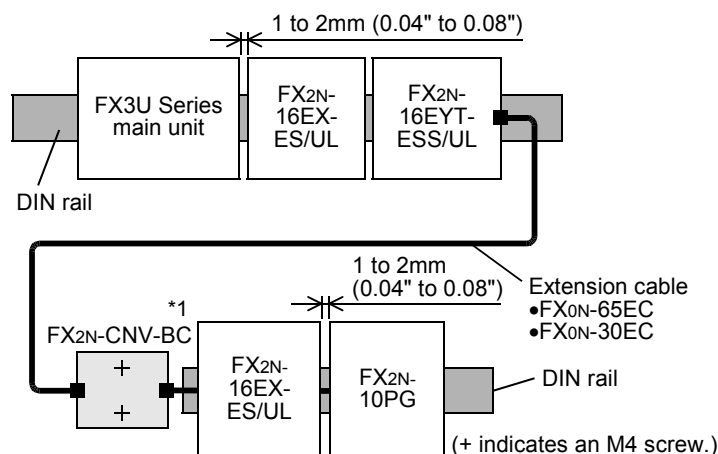

- *1. FX2N-CNV-BC can be installed directly in the enclosure but cannot be installed on the DIN rail.

2. Example of direct installation

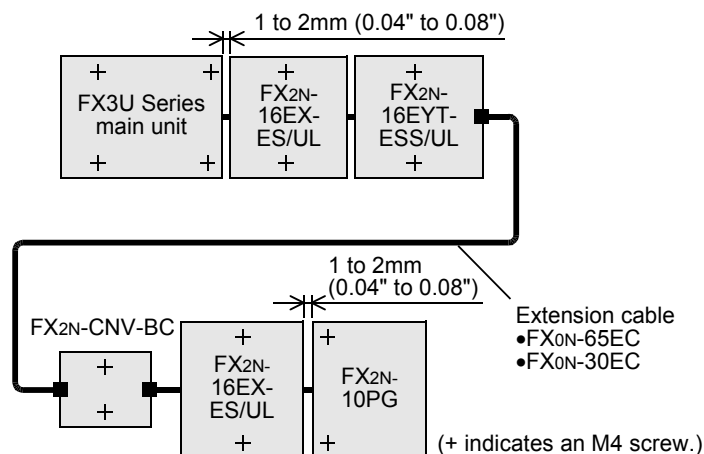

3. Example of combination of installation on DIN rail and direct installation

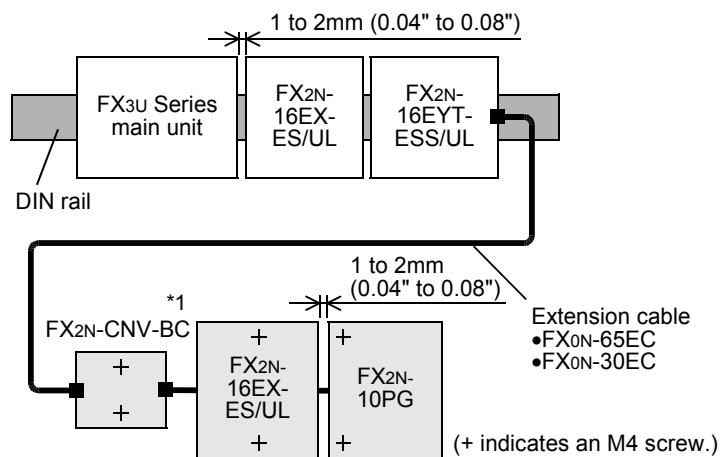

*1. FX2N-CNV-BC can be installed directly in the enclosure but cannot be installed on the DIN rail.

8.5 Procedures for Installing on and Detaching from DIN Rail

The main unit can be installed on a 35 mm (1.38") wide DIN46277 rail.

8.5.1 Preparation for installation

1. Connecting extension devices

Some extension devices must be mounted on the main unit before the unit is installed in the enclosure.

- Mount the expansion board and special adapters on the main unit before installing it in the enclosure.
- Mount the input/output powered extension units/blocks and the special function units/blocks in the enclosure after installing the main unit in the enclosure.
- The memory cassette and the display module can be fitted to the main unit after it is installed.
- The battery can be replaced with a new one in the state where the main unit is in the enclosure.

→ **For the replacement procedures, refer to Chapter 22.**

2. Affixing The Dust Proof Sheet

The dust proof sheet should be affixed to the ventilation port before beginning the installation and wiring work.

→ **For the affixing procedure, refer to the instructions on the dust proof sheet.**

Be sure to remove the dust proof sheet when the installation and wiring work is completed.

1

Introduction

2

Features and
Part Names

3

Product
Introduction

4

Specifications

5

Version and
Peripheral
Devices

6

System
Configuration

7

Input/Output
Nos., Unit Nos.

8

Installation

9

Preparation and
Power Supply
Wiring

10

Input Wiring

8.5.2 Installation of main unit

The main unit must be installed before installing an expansion board or special adapter on the enclosure.

→ For the connection procedure, refer to Subsection 8.7.2, 8.7.3, and 9.5.2.

- 1 Push out all DIN rail mounting hooks (A in the right figure).

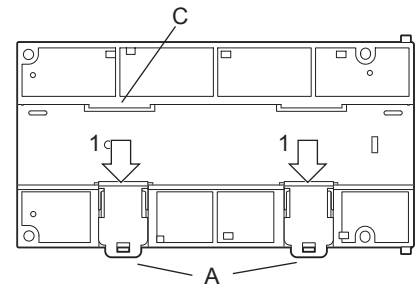
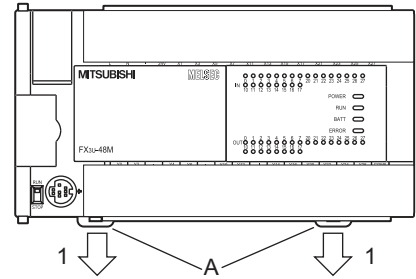

- 2 Fit the upper edge of the DIN rail mounting groove (C in the right figure) onto the DIN rail.

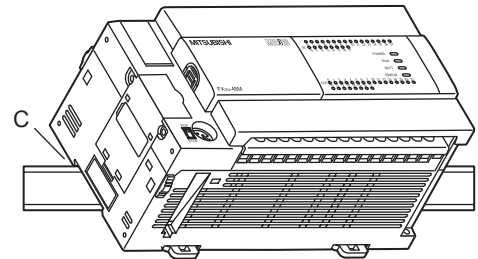

- 3 Lock the DIN rail mounting hooks (D in the following figure) while pressing the PLC against the DIN rail.

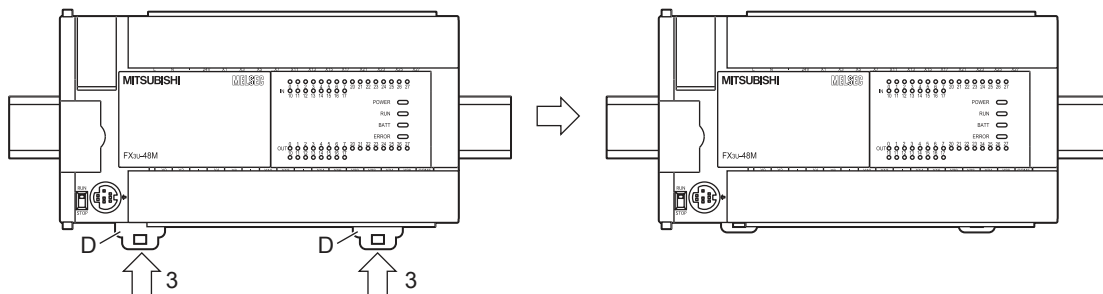

8.5.3 Installation of input/output powered extension unit/block and special function unit/block

1 Push out the DIN rail mounting hook (A in the right figure) of the input/output extension block.

- For input/output powered extension units, 8-point type input/output extension blocks (except for the FX2N-8EYR-S-ES/UL) and special extension units/blocks, this operation is unnecessary.

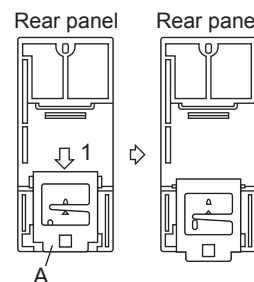

2 Fit the upper edge of the DIN rail mounting groove (B in the right figure) onto the DIN rail.

3 Push the product against the DIN rail.

- Keep a gap of 1 to 2 mm (0.04" to 0.08") between the products.

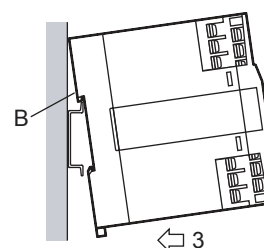

4 Connect the extension cable.

→ For the procedures on connecting the extension cable, refer to Subsection 8.7.4.

8.5.4 Removal of main unit

1 Open the terminal block covers, and remove the protective terminal covers (A in the right figure).

2 Gradually loosen the left and right terminal block mounting screws (B in the right figure), and remove the terminal blocks.

- The terminal block cannot be removed from the FX3U-16M□ main unit

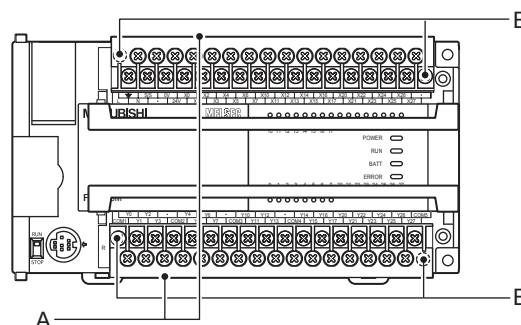

→ For anchoring of the terminal block, refer to Subsection 9.1.2.

3 Disconnect the extension cables and the connecting cables (including expansion board and special adapters).

1	Introduction
2	Features and Part Names
3	Product Introduction
4	Specifications
5	Version and Peripheral Devices
6	System Configuration
7	Input/Output Nos., Unit Nos.
8	Installation
9	Preparation and Power Supply Wiring
10	Input Wiring

4 Insert the tip of a flathead screwdriver into the hole of the DIN rail mounting hook (C in the right figure).

- This step also applies for the DIN rail mounting hooks of the special adapters.

5 Move the flathead screwdriver as shown in the right figure to draw out the DIN rail mounting hooks of all devices.

6 Remove the product from the DIN rail (D in the right figure).

7 Push in the DIN rail mounting hooks (E in the right figure).

- For input/output powered extension units, 8-point type input/output extension blocks (except for the FX_{2N}-8EYR-S-ES/UL) and special extension units/blocks, this operation is unnecessary.

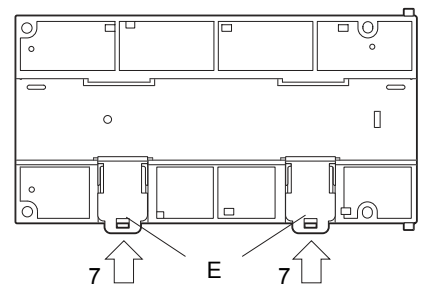
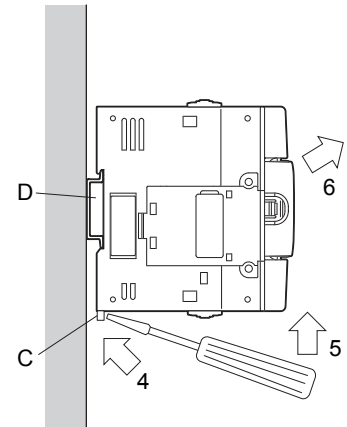

8.6 Procedures for Installing Directly (with M4 Screws)

The product can be installed directly in the enclosure (with screws).

Point

Position the holes so that there is a gap of 1 to 2 mm (0.04" to 0.08") between the products.

8.6.1 Hole pitches for direct mounting

The product mounting hole pitches are shown below.
For the pitch that varies depending on the product, refer to the table.

1. Main unit (A or B)

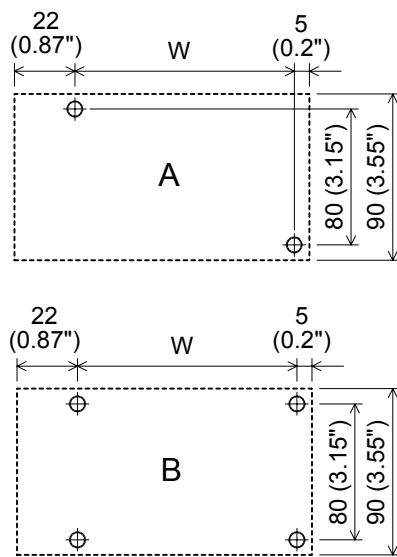

		Unit: mm (inches)
	Model name	Mounting hole pitch (W)
A	FX3U-16MR/ES	103 (4.06")
	FX3U-16MT/ES	
	FX3U-16MT/ESS	
	FX3U-16MR/DS	
	FX3U-16MT/DS	
	FX3U-16MT/DSS	123 (4.85")
	FX3U-32MR/ES	
	FX3U-32MT/ES	
	FX3U-32MT/ESS	
	FX3U-32MS/ES	
FX3U-32MR/DS	155 (6.11")	
FX3U-32MT/DS		
FX3U-32MT/DSS		
FX3U-32MR/UA1		
FX3U-48MR/ES		
B	FX3U-48MT/ES	193 (7.6")
	FX3U-48MT/ESS	
	FX3U-48MR/DS	
	FX3U-48MT/DS	
	FX3U-48MT/DSS	
	FX3U-64MR/ES	258 (10.16")
	FX3U-64MT/ES	
	FX3U-64MT/ESS	
	FX3U-64MS/ES	
	FX3U-64MR/DS	
	FX3U-64MT/DS	323 (12.72")
	FX3U-64MT/DSS	
	FX3U-64MR/UA1	
	FX3U-80MR/ES	
FX3U-80MT/ES		
FX3U-80MT/ESS	323 (12.72")	
FX3U-80MR/DS		
FX3U-80MT/DS		
FX3U-80MT/DSS		
FX3U-128MR/ES	323 (12.72")	
FX3U-128MT/ES		
FX3U-128MT/ESS		

1	Introduction
2	Features and Part Names
3	Product Introduction
4	Specifications
5	Version and Peripheral Devices
6	System Configuration
7	Input/Output Nos., Unit Nos.
8	Installation
9	Preparation and Power Supply Wiring
10	Input Wiring

2. Special adapter (C)

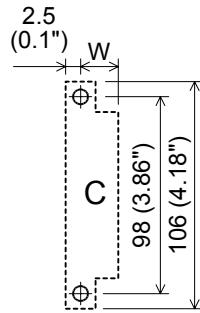

Unit: mm (inches)

	Model name	Mounting hole pitch(W)
C	FX3U-4AD-ADP	15.1 (0.6")
	FX3U-4DA-ADP	
	FX3U-3A-ADP	
	FX3U-4AD-PT-ADP	
	FX3U-4AD-PTW-ADP	
	FX3U-4AD-PNK-ADP	
	FX3U-4AD-TC-ADP	
	FX3U-232ADP(-MB)	
	FX3U-485ADP(-MB)	
	FX3U-4HSX-ADP	
FX3U-2HSY-ADP		
	FX3U-CF-ADP	42.5 (1.68")

3. Input/output powered extension unit (D or E)

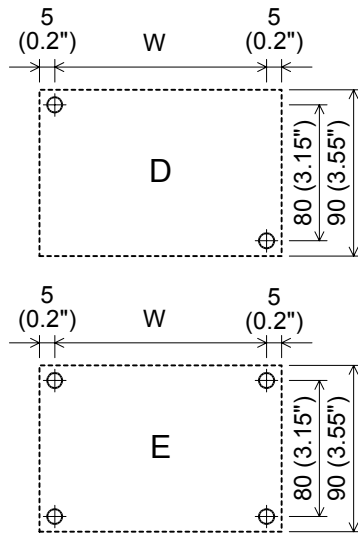

Unit: mm (inches)

	Model name	Mounting hole pitch(W)
D	FX2N-32ER-ES/UL	140 (5.52")
	FX2N-32ET-ESS/UL	
	FX2N-32ER	
	FX2N-32ET	
	FX2N-32ES	
E	FX2N-48ER-ES/UL	172 (6.78")
	FX2N-48ET-ESS/UL	
	FX2N-48ER	
	FX2N-48ET	
	FX2N-48ER-DS	
	FX2N-48ET-DSS	
	FX2N-48ER-D	
	FX2N-48ET-D	
	FX2N-48ER-UA1/UL	210 (8.27")

4. Input/output extension block (F or G)

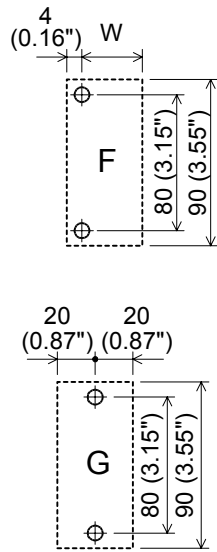

Unit: mm (inches)		
	Model name	Mounting hole pitch (W)
F	FX2N-8ER-ES/UL FX2N-8ER FX2N-8EX-ES/UL FX2N-8EX FX2N-8EX-UA1/UL FX2N-8EYR-ES/UL FX2N-8EYT-ESS/UL FX2N-8EYR FX2N-8EYT FX2N-8EYT-H	39 (1.54")
G	FX2N-8EYR-S-ES/UL FX2N-16EX-ES/UL FX2N-16EX FX2N-16EX-C FX2N-16EXL-C FX2N-16EYR-ES/UL FX2N-16EYR FX2N-16EYT-ESS/UL FX2N-16EYT FX2N-16EYT-C FX2N-16EYS	Refer to the figure shown left.

5. Special function unit/block (H, I, J or K)

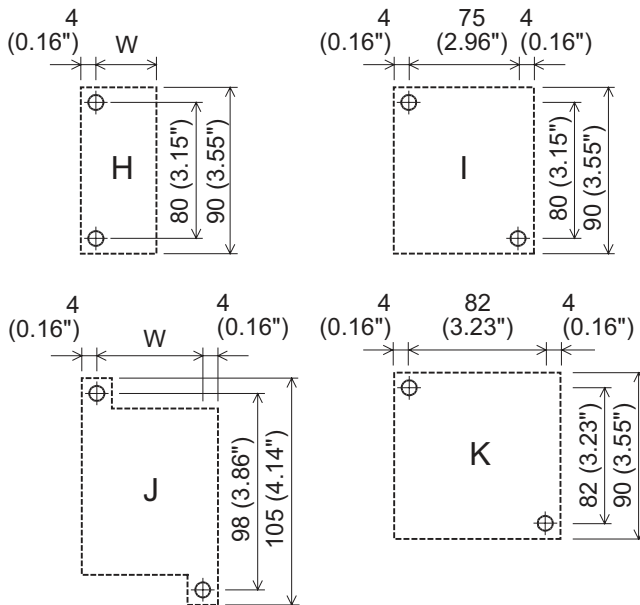

Unit: mm (inches)			
	Model name	Mounting hole pitch(W)	
H	FX0N-3A FX2N-2AD FX2N-2DA FX2N-1PG FX2N-1PG-E FX2N-10PG FX2N-64CL-M FX2N-32CCL FX2N-16LNK-M	39 (1.54")	
	FX3U-4AD FX3U-4DA FX3U-2HC FX3U-20SSC-H FX3U-16CCL-M FX3U-64CCL FX3U-1PSU-5V FX2N-4AD FX2N-4DA FX2N-4AD-PT FX2N-4AD-TC FX2N-5A FX2N-2LC FX2N-1HC FX2N-1RM-SET FX2N-1RM-E-SET FX2N-232IF FX2N-32ASI-M	51 (2.01")	
	I	FX2N-16CCL-M	Refer to the figure shown left.
	J	FX2N-8AD	67 (2'64")
		FX2N-20PSU	52 (2'05")
	K	FX3U-4LC	Refer to the figure shown left.
	-	FX2N-10GM FX2N-20GM	These units cannot be installed directly.

1	Introduction
2	Features and Part Names
3	Product Introduction
4	Specifications
5	Version and Peripheral Devices
6	System Configuration
7	Input/Output Nos., Unit Nos.
8	Installation
9	Preparation and Power Supply Wiring
10	Input Wiring

8.6.2 Example of mounting hole pitches

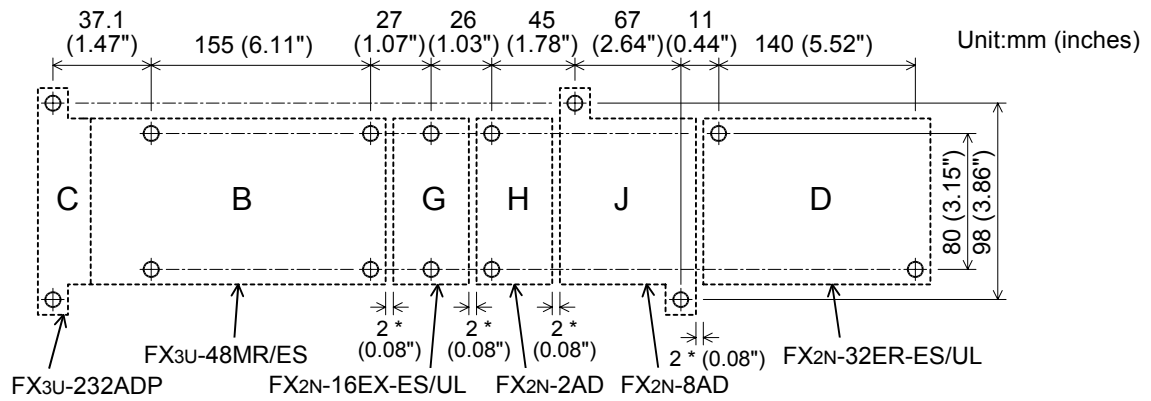

* The gap between products is 2 mm (0.08").

8.6.3 Installation of main unit

Mount the expansion board and special adapters on the main unit before installing the unit in the enclosure.
→ For the connection procedure, refer to Subsection 8.7.2, 8.7.3, and 9.5.2.

- 1 Make mounting holes in the mounting surface according to the external dimensions diagram.
- 2 Fit the main unit (A in the right figure) based on the holes, and secure it with M4 screws (B in the right figure).

The positions and number of screws depend on the product. Refer to the external dimensions diagram.
→ For the external dimensions, refer to Section 4.6.

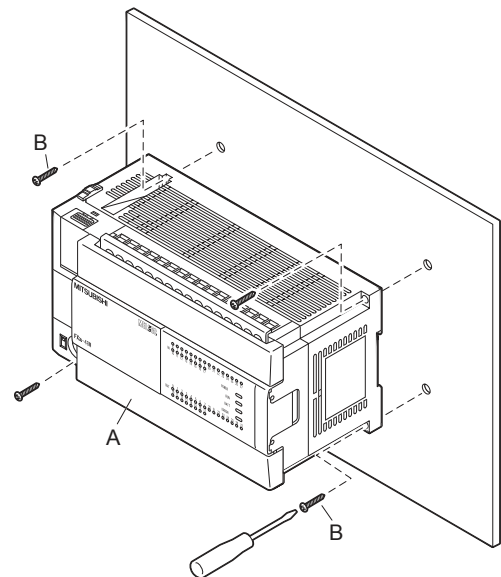

8.6.4 Installation of input/output powered extension unit/block and special function unit/block

- 1 Make mounting holes in the mounting surface according to the external dimensions diagram
- 2 Push in the DIN rail mounting hook (A in the right figure) of the input/output extension block.

If the DIN rail mounting hook is not pushed in, the screw hole is covered, and the block cannot be mounted.

For input/output powered extension units, 8-point type input/output extension blocks (except for the FX2N-8EYR-S-ES/UL) and special extension units/blocks, this operation is unnecessary.

- 3 Fit the input/output extension block (B in the right figure) based on the holes, and secure it with M4 screws (C in the right figure).

The positions and number of screws depend on the product. Refer to the external dimensions diagram.
→ For the external dimensions of the input/output powered extension unit, refer to Chapter 15.
→ For the external dimensions of the input/output extension block, see Chapter 16.
→ For the external dimensions of the special function units/blocks, see Chapter 18.

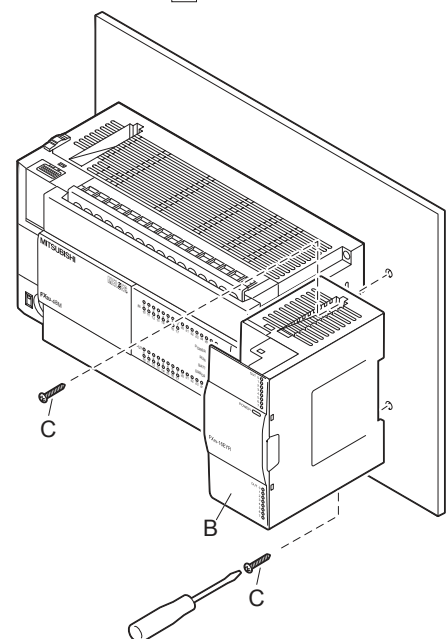
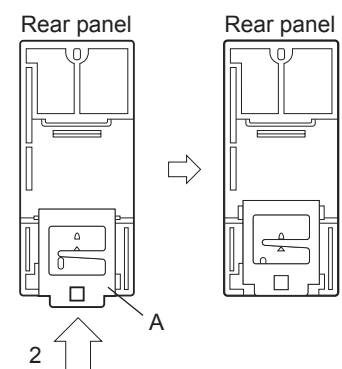

1	Introduction
2	Features and Part Names
3	Product Introduction
4	Specifications
5	Version and Peripheral Devices
6	System Configuration
7	Input/Output Nos., Unit Nos.
8	Installation
9	Preparation and Power Supply Wiring
10	Input Wiring

8.7 Connecting Methods for Main Unit and Extension Devices

This section explains the connecting methods for extension devices.

8.7.1 Connection of extension devices

The connecting method varies depending on the combination of the products, i.e. the main unit, expansion board, special adapters, input/output extension blocks and special function units/blocks. The connecting methods are explained with the following configuration examples.

Example of configuration

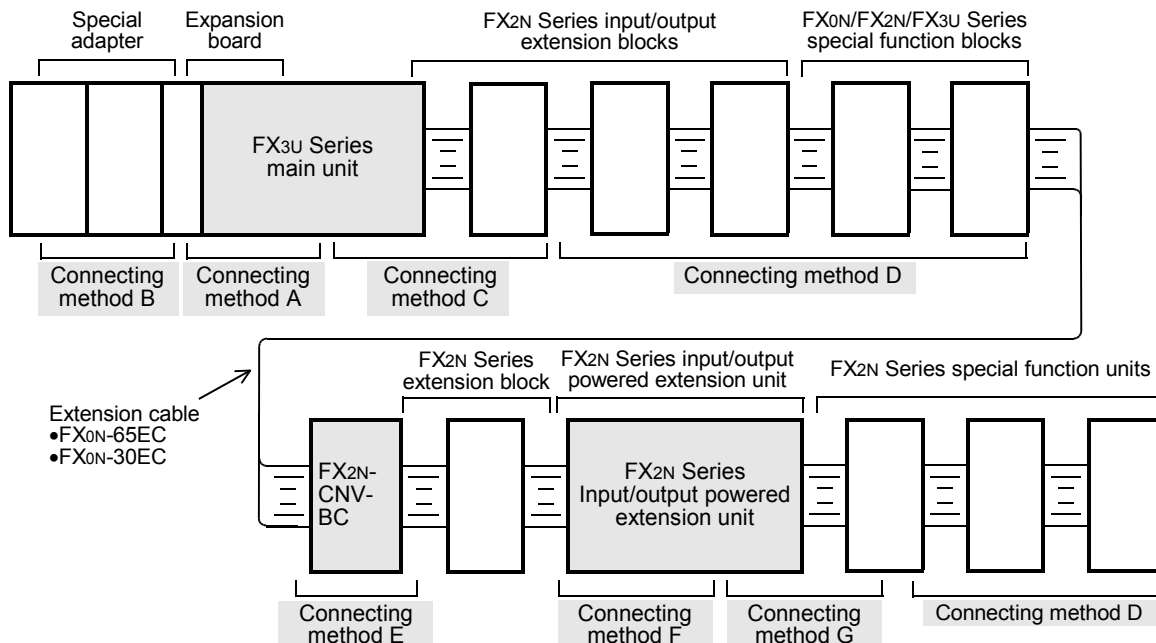

8.7.2 Connecting method A - connection of expansion board

To connect an expansion board to the main unit in the enclosure, it is necessary to remove the main unit from the enclosure.

- Refer to Subsection 8.5.4 for the "removal from DIN rail" procedure.
- Refer to Section 8.6 for the "direct mounting" removal procedure.

- 1** Insert the tip of a flathead screwdriver into the part A of the expansion board compartment dummy cover (B in the right figure) on the left side of the main unit, and slightly lift the dummy cover.

- Put the main unit on the edge of a desk or so to insert the screwdriver.

Caution

Take care not to damage the wiring board and electronic components with the screwdriver.

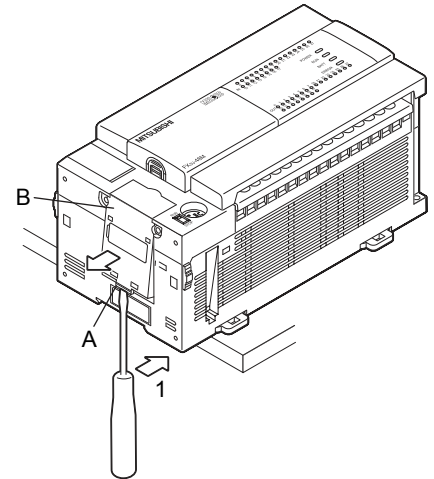

- 2** Remove the expansion board compartment dummy cover (B in the right figure).

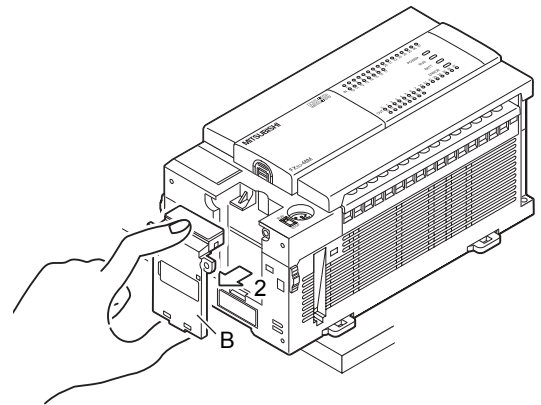

- 3** Hold the expansion board (C in the right figure) parallel to the main unit, and fit the board to the expansion board connector.

- 4** Secure the expansion board (C in the right figure) on the main unit with the supplied M3 tapping screws (D in the right figure).

- Tightening torque: 0.3 to 0.6 N·m

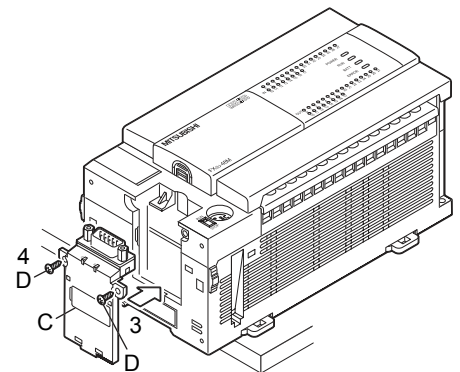

1

Introduction

2

Features and
Part Names

3

Product
Introduction

4

Specifications

5

Version and
Peripheral
Devices

6

System
Configuration

7

Input/Output
Nos., Unit Nos.

8

Installation

9

Preparation and
Power Supply
Wiring

10

Input Wiring

8.7.3 Connecting method B - connection of special adapter

When an expansion board is used, connect the board as stated in the previous subsection before connecting the special adapter.

When a high-speed input/output special adapter is used, fit the adapter before connecting other special adapters.

1 Remove the special adapter connector cover (A in the right figure) from the expansion board.

- When fitting a high-speed input/output special adapter, also remove the high-speed input/output special adapter connector cover (C in the right figure).
- When adding a special adapter to the special adapter that has been connected to the expansion board, read "expansion board" as "special adapter."

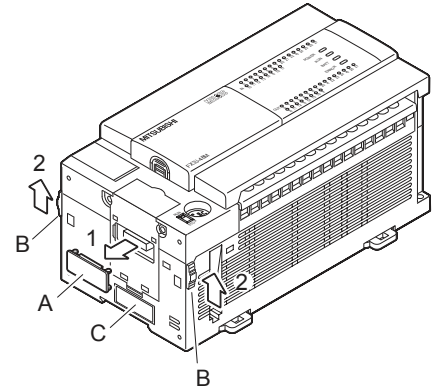

2 Slide the special adapter connecting hooks (B in the right figure) of the main unit.

- When adding a special adapter to the special adapter that has been connected to the main unit, read "main unit" as "special adapter." (This applies to the following steps.)

3 Connect the special adapter (C in the right figure) to the main unit as shown in the right figure.

4 Slide the special adapter connecting hooks (B in the right figure) of the main unit to secure the special adapter (C in the right figure).

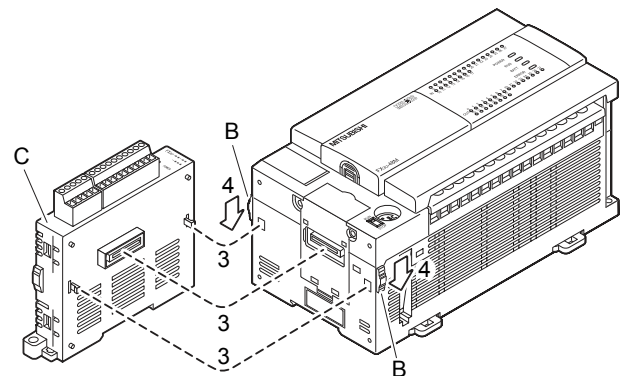

8.7.4 Connecting method C - connection of powered extension unit/block to main unit

The procedures for connecting a powered extension unit/block to the main unit are explained below.

1 Remove the extension device connector cover (A in the right figure) on the right side of the main unit.

2 Connect the extension cable (B in the right figure) from the extension block to be connected (right side) to the extension device connector of the main unit.

- When connecting FX2N Series input/output powered extension unit, FX2N-10GM, FX2N-20GM, FX2N-1RM(-E)-SET or FX3U-1PSU-5V, connect the unit to be added (right side) and the existing unit (main unit) with the supplied extension cable.

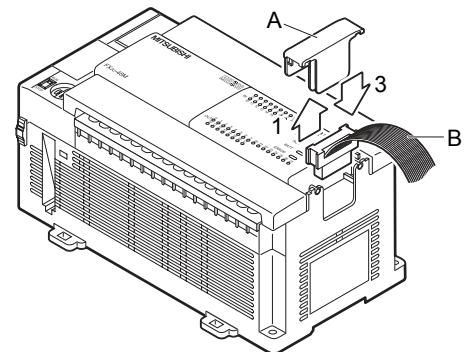

3 Fit the extension device connector cover (A in the right figure).

8.7.5 Connecting method D - connection of powered extension units/blocks

This subsection explains the procedures for connecting FX2N Series input/output powered extension units/blocks or FX0N/FX2N/FX3U Series special function units/blocks.

1 Remove the top cover (B in the right figure) of the existing unit/block (left side) (A in the right figure).

- When connecting FX2N-10GM or FX2N-20GM, remove the PLC extension block connector cover.
- When connecting FX2N-1RM(-E)-SET or FX3U-1PSU-5V, remove the top cover of FX2N-1RM(-E)-SET or FX3U-1PSU-5V.

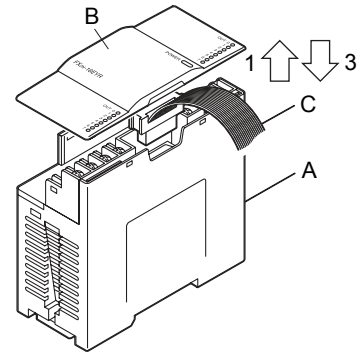

2 Connect the extension cable (C in the above figure) of the block to be connected (right side) to the existing unit/block (A in the above figure).

- When FX2N Series input/output powered extension units, FX2N-10GM, FX2N-20GM, FX2N-1RM(-E)-SET or FX3U-1PSU-5V units are connected, connect the unit to be added (right side) and the existing unit (left side) with the supplied extension cable.

3 Fit the top cover (B in the above figure) (except when connecting FX2N-10GM or FX2N-20GM).

8.7.6 Connecting method E - connection of extension cable and FX2N-CNV-BC

This subsection explains the procedures for connecting an extension cable and FX2N-CNV-BC to the extension cable of the powered extension unit/block.

1 Separate the case of FX2N-CNV-BC into two pairs as shown right.

To separate the case, use a precision flathead screwdriver.

Slightly insert the tip of the screwdriver into the part A shown in the right figure, and the hook (B in the right figure) will come off (4 places).

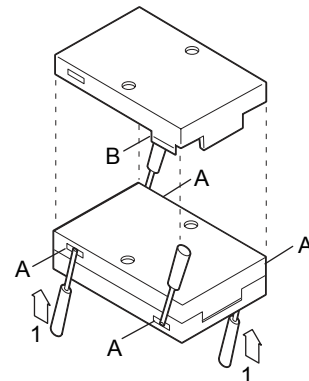

2 Connect the extension cable on the upstream side (C in the right figure).

3 Connect the extension cable on the downstream side (D in the right figure).

4 Fit the upper cover (E in the right figure) and the lower cover (F in the right figure), and press down the upper cover until it is hooked.

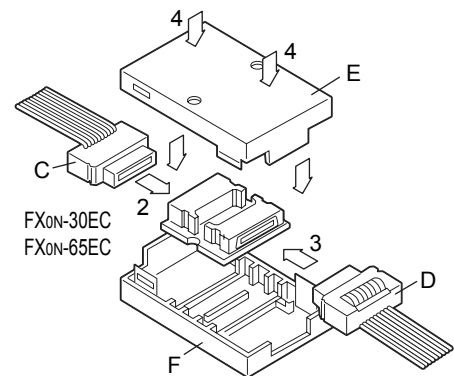

8.7.7 Connecting method F - connection of input/output powered extension unit

This subsection explains the procedures for connecting an input/output powered extension unit.

1 Remove the top cover (A in the right figure) on the left side of the input/output powered extension unit.

2 Connect the connector of the extension cable (supplied) (B in the right figure) to the extension connector.

3 Connect the connector of the extension cable (supplied) (B in the right figure) to the extension connector of the unit to be added (right side).

4 Fit the top cover (A in the right figure).

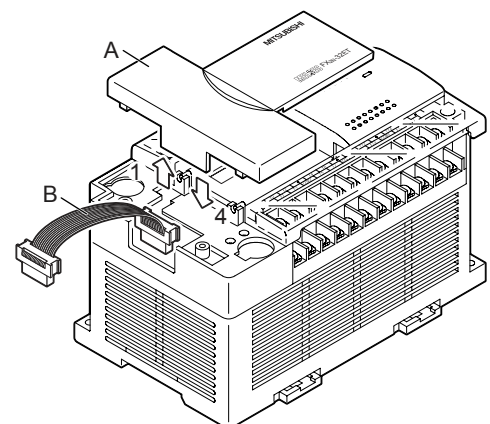

8.7.8 Connecting method G - connection of extension block to input/output powered extension unit

This subsection explains the procedures for connecting an input/output extension block to an input/output powered extension unit.

1 Remove the extension connector cover (A in the right figure) on the right side of the input/output powered extension unit.

2 Connect the extension cable (B in the right figure) from the extension block to be added (right side) to the extension connector of the input/output powered extension unit.

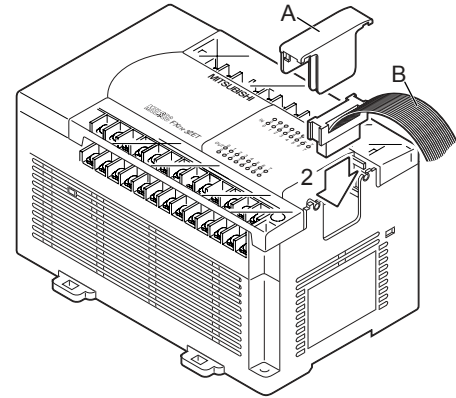

- When connecting FX2N-10GM, FX2N-20GM, FX2N-1RM(-E)-SET or FX3U-1PSU-5V, read "input/output powered extension unit" as the unit.
- When connecting FX2N Series input/output powered extension unit, FX2N-10GM, FX2N-20GM, FX2N-1RM(-E)-SET or FX3U-1PSU-5V, connect the unit to be added (right side) and the existing unit (main unit) with the supplied extension cable or the optional extension cable.
 - For FX2N Series input/output powered extension unit, FX2N-1RM(-E)-SET or FX3U-1PSU-5V, the extension cable FX0N-30EC or FX0N-65EC can be used.
 - For FX2N-10GM or FX2N-20GM, the extension cable FX2N-GM-65EC can be used.

3 Fit the extension connector cover (A in the right figure).

9. Preparation for Wiring and Power Supply Wiring Procedures

DESIGN PRECAUTIONS



DANGER

- Make sure to have the following safety circuits outside of the PLC to ensure safe system operation even during external power supply problems or PLC failure.
Otherwise, malfunctions may cause serious accidents.
 - 1) Most importantly, have the following: an emergency stop circuit, a protection circuit, an interlock circuit for opposite movements (such as normal vs. reverse rotation), and an interlock circuit (to prevent damage to the equipment at the upper and lower positioning limits).
 - 2) Note that when the PLC CPU detects an error, such as a watchdog timer error, during self-diagnosis, all outputs are turned off. Also, when an error that cannot be detected by the PLC CPU occurs in an input/output control block, output control may be disabled.
External circuits and mechanisms should be designed to ensure safe machinery operation in such a case.
 - 3) Note that the output current of the 24V DC service power supply varies depending on the model and the absence/presence of extension blocks. If an overload occurs, the voltage automatically drops, inputs in the PLC are disabled, and all outputs are turned off.
External circuits and mechanisms should be designed to ensure safe machinery operation in such a case.
 - 4) Note that when an error occurs in a relay, triac or transistor output device, the output could be held either on or off.
For output signals that may lead to serious accidents, external circuits and mechanisms should be designed to ensure safe machinery operation in such a case.

DESIGN PRECAUTIONS



CAUTION

- Do not bundle the control line together with or lay it close to the main circuit or power line. As a guideline, lay the control line at least 100mm (3.94") or more away from the main circuit or power line.
Noise may cause malfunctions.
- Install module so that excessive force will not be applied to peripheral device connectors.
Failure to do so may result in wire damage/breakage or PLC failure.

WIRING PRECAUTIONS



DANGER

- Make sure to cut off all phases of the power supply externally before attempting installation or wiring work.
Failure to do so may cause electric shock or damage to the product.
- Make sure to attach the terminal cover, offered as an accessory, before turning on the power or initiating operation after installation or wiring work.
Failure to do so may cause electric shock.

WIRING PRECAUTIONS



- Do not supply power to the [24+] and [24V] terminals (24V DC service power supply) on the main unit or extension units.
Doing so may cause damage to the product.
- Perform class D grounding (grounding resistance: 100 Ω or less) to the grounding terminal on the main unit and extension units with a wire 2 mm² or thicker.
Do not use common grounding with heavy electrical systems (refer to Section 9.4).
- Connect the AC power supply wiring to the dedicated terminals described in this manual.
If an AC power supply is connected to a DC input/output terminal or DC power supply terminal, the PLC will burn out.
- Connect the DC power supply wiring to the dedicated terminals described in this manual.
If an AC power supply is connected to a DC input/output terminal or DC power supply terminal, the PLC will burn out.
- Do not wire vacant terminals externally.
Doing so may damage the product.
- When drilling screw holes or wiring, make sure that cutting and wiring debris do not enter the ventilation slits.
Failure to do so may cause fire, equipment failures or malfunctions.
- Make sure to properly wire the FX3U Series main unit and FX0N/FX2N/FX3U Series extension equipment in accordance with the following precautions.
Failure to do so may cause electric shock, equipment failures, a short-circuit, wire breakage, malfunctions, or damage to the product.
 - The disposal size of the cable end should follow the dimensions described in the manual.
 - Tightening torque should follow the specifications in the manual.
- Make sure to properly wire to the terminal block (European type) in accordance with the following precautions.
Failure to do so may cause electric shock, equipment failures, a short-circuit, wire breakage, malfunctions, or damage to the product.
 - The disposal size of the cable end should follow the dimensions described in the manual.
 - Tightening torque should follow the specifications in the manual.
 - Twist the end of strand wire and make sure that there are no loose wires.
 - Do not solder-plate the electric wire ends.
 - Do not connect more than the specified number of wires or electric wires of unspecified size.
 - Affix the electric wires so that neither the terminal block nor the connected parts are directly stressed.
- Make sure to properly wire to the FX Series terminal blocks in accordance with the following precautions.
Failure to do so may cause electric shock, equipment failures, a short-circuit, wire breakage, malfunctions, or damage to the product.
 - The disposal size of the cable end should follow the dimensions described in the manual.
 - Tightening torque should follow the specifications in the manual.

This chapter explains the procedures for wiring, cabling and wiring the power supply.
The input/output wiring procedures are stated in the following chapter.

- Wiring procedures
- Procedures for connecting cables to various shapes of power supply and input/output terminals
- Procedures for the wiring power supply

1	Introduction
2	Features and Part Names
3	Product Introduction
4	Specifications
5	Version and Peripheral Devices
6	System Configuration
7	Input/Output Nos., Unit Nos.
8	Installation
9	Preparation and Power Supply Wiring
10	Input Wiring

9.1 Preparation for Wiring

9.1.1 Wiring procedures

Before starting wiring work, make sure that the main power is off.

1 Prepare the parts for wiring.

Prepare the solderless terminals and cables necessary for wiring.

→ For details, refer to Section 9.2.

2 Wire the power supply terminals.

In the case of AC power supply type

Connect the power supply to the terminals [L] and [N].

In the case of DC power supply type

Connect the power supply to the terminals [\oplus] and [\ominus].

Provide the power supply circuit with the protection circuit shown in this subsection.

→ For details, refer to Section 9.5.

3 Wire the ground terminal [] at a grounding resistance of 100Ω or less (Class D).

Connect a class D ground wire to the terminal.

→ For details, refer to Section 9.4 and 9.5.

4 Wire the input [X] terminals.

For a type (24V DC input type) common to sink/source input, select sink or source input by the following connection.

In the case of AC power supply type

- For sink input, connect the [24V] and [S/S] terminals.
- For source input, connect the [0V] and [S/S] terminals.

In the case of DC power supply type

- For sink input, connect the [\oplus] and [S/S] terminals.
- For source input, connect the [\ominus] and [S/S] terminals.
Connect sensors and switches to the terminals.

→ For details, refer to Chapter 10.

5 Wire the output [Y] terminals.

Connect loads to the terminals.

→ For details, refer to Chapter 12.

9.1.2 Removal and installation of quick-release terminal block (Except for the FX3U-16M□)

Removal Unscrew the terminal block mounting screws [both right and left screws] evenly, and remove the terminal block.

Installation Place the terminal block in the specified position, and tighten the terminal block mounting screws evenly [both right and left screws].

Tightening torque 0.4 to 0.5 N•m

Do not tighten the terminal block mounting screws exceeding the specified torque. Failure to do so may cause equipment failures or malfunctions.

*Pay attention so that the center of the terminal block is not lifted.

9.2 Cable Connecting Procedures

For cable connection, a terminal block or a connector is used. The cable connecting procedures are explained below.

9.2.1 Input/output terminal block (power supply and input/output wiring)

WIRING PRECAUTIONS	 DANGER
<ul style="list-style-type: none"> • Make sure to cut off all phases of the power supply externally before attempting installation or wiring work. Failure to do so may cause electric shock or damage to the product. • Make sure to attach the terminal cover offered as an accessory to the product before turning on the power or starting the operation after installation or wiring work. Failure to do so may cause electric shock. 	

WIRING PRECAUTIONS	 CAUTION
<ul style="list-style-type: none"> • Make sure to properly wire the FX3U Series main unit and FX0N/FX2N/FX3U Series extension equipment in accordance with the following precautions. Failure to do so may cause electric shock, equipment failures, a short-circuit, wire breakage, malfunctions, or damage to the product. <ul style="list-style-type: none"> - The disposal size of the cable end should follow the dimensions described in the manual. - Tightening torque should follow the specifications in the manual. • Make sure to properly wire to the FX Series terminal blocks in accordance with the following precautions. Failure to do so may cause electric shock, equipment failures, a short-circuit, wire breakage, malfunctions, or damage to the product. <ul style="list-style-type: none"> - The disposal size of the cable end should follow the dimensions described in the manual. - Tightening torque should follow the specifications in the manual. 	

For the main unit, FX2N Series input/output powered extension units/blocks and FX0N/FX2N/FX3U Series special function units/blocks, an M3 or M3.5 screw terminal block is used.

1. Applicable products

Product type	Model name
Main unit	All models of FX3U Series main units
Input/output powered extension unit	All models of FX2N Series input/output powered extension units
Input/output extension block	All models of FX2N Series input/output extension blocks (except for the FX2N-16EX-C, FX2N-16EXL-C and FX2N-16EYT-C)
Extension power supply unit	FX3U-1PSU-5V
Special function unit/block	Refer to the manual for each product.
FX Series terminal block	All models
Power supply unit	FX2N-20PSU

2. Terminal block screw size and tightening torque

The size of the terminal screws for each product is shown below. For the solderless terminals, refer to the following page.

Product	Terminal screw	Tightening torque
Main unit	M3	0.5 to 0.8N·m
FX2N Series input/output powered extension units		
FX2N Series input/output extension blocks		
FX Series terminal block	M3.5	
Special function unit/block	Refer to the manual for each product.	

3. Wire end treatment

The solderless terminal size depends on the terminal screw size and wiring method.

- Use solderless terminals of the following size.
- Tighten the terminals to a torque of 0.5 to 0.8 N•m.
 Do not tighten terminal screws exceeding the specified torque.
 Failure to do so may cause equipment failures or malfunctions.

In case of M3 terminal screw

- When one wire is connected to one terminal

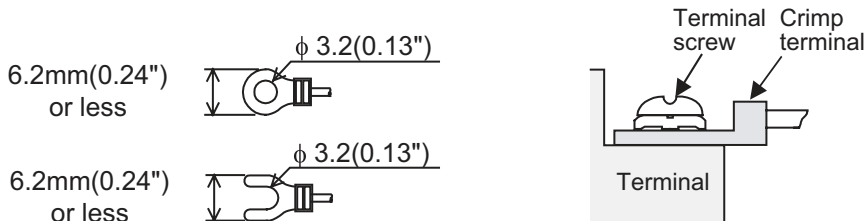

<Reference>

Terminal Manufacturer	Type No.	Certification	Pressure Bonding Tool
JAPAN SOLDERLESS TERMINAL MFG CO LTD (JST)	FV1.25-B3A	UL Listed	YA-1(JST)
	FV2-MS3		

- When two wires are connected to one terminal

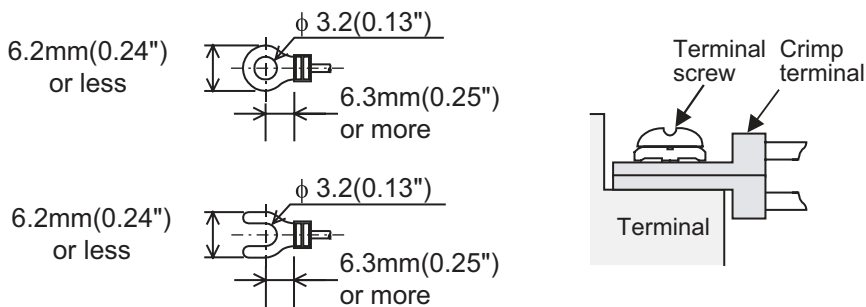

<Reference>

Terminal Manufacturer	Type No.	Certification	Pressure Bonding Tool
JAPAN SOLDERLESS TERMINAL MFG CO LTD (JST)	FV1.25-B3A	UL Listed	YA-1(JST)

In case of M3.5 terminal screw

- When one wire is connected to one terminal

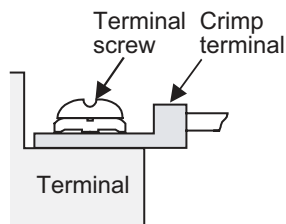
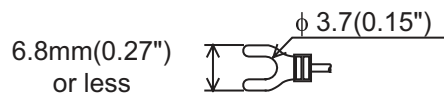
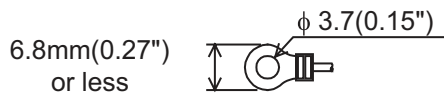

- When two wires are connected to one terminal

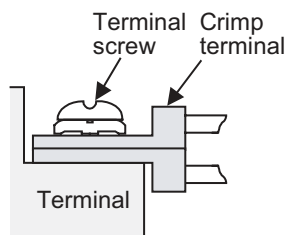
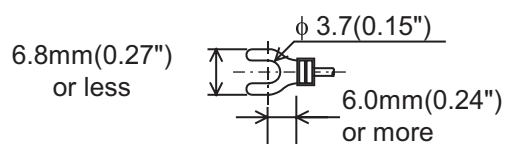
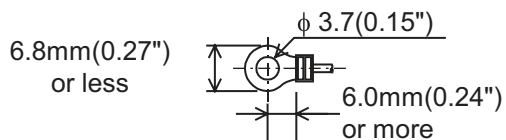

1	Introduction
2	Features and Part Names
3	Product Introduction
4	Specifications
5	Version and Peripheral Devices
6	System Configuration
7	Input/Output Nos., Unit Nos.
8	Installation
9	Preparation and Power Supply Wiring
10	Input Wiring

9.2.2 Input/output connectors

The input/output connectors of FX2N Series input/output extension blocks (connector type) and special function units/blocks (connector type) conform to MIL-C-83503.

Prepare the input/output cables, referring to the following tables.

1. Applicable products

Classification	Model names
Input/output extension blocks	FX2N-16EX-C, FX2N-16EXL-C, FX2N-16EYT-C
Special function units/blocks	FX3U-20SSC-H, FX3U-2HC, FX2N-10PG, FX2N-10GM, FX2N-20GM

2. Preparation of input/output connectors

- Compliant connectors (commercially available connectors)
Use 20-pin (1-key) or 40-pin (1-key) sockets conforming to MIL-C-83503.
In advance, make sure that no interference is caused with peripheral parts, such as the connector cover.
- Input/output cables (our options)
Input/output cables with attached connectors are available.
The following input/output cables are intended to be used only for general purpose input and output operations.

Model names	Length	Description	Shape
FX-16E-500CAB-S	5m(10'4")	General-purpose input/output cable	<ul style="list-style-type: none"> Single wire (Wire color : red) PLC side : A 20-pin connector
FX-16E-150CAB	1.5m(4'11")	Cables for connecting FX Series terminal block and input/output connector For the connection with FX Series terminal block, refer to the following chapter. → Chapter 20 "FX-16/32E*-* TB (Terminal Block)"	<ul style="list-style-type: none"> Flat cables (with tube) A 20-pin connector at both ends
FX-16E-300CAB	3m(9'10")		
FX-16E-500CAB	5m(10'4")		
FX-16E-150CAB-R	1.5m(4'11")		
FX-16E-300CAB-R	3m(9'10")		
FX-16E-500CAB-R	5m(10'4")		
FX-A32E-150CAB	1.5m(4'11")	Cables for connecting A Series Model A6TBXY36 connector/terminal block conversion unit and input/output connector type	<ul style="list-style-type: none"> Flat cables (with tube) PLC side : Two 20-pin connectors in 16-point units Terminal block side : A dedicated connector One common terminal covers 32 input/output terminals.
FX-A32E-300CAB	3m(9'10")		
FX-A32E-500CAB	5m(10'4")		

- Connectors for making input/output cables by users (our options)
The users should prepare the electric wires and pressure bonding tool.

Model name and composition of input/output connector		Applicable electric wire (UL-1061 are recommended) and tool		
Our model name	Details of part (made by DDK Ltd.)	Electric wire size	Pressure bonding tool (made by DDK Ltd.)	
FX2c-I/O-CON for flat cable	10-piece set	Solderless connector FRC2-A020-30S	AWG28 (0.1mm ²), 1.27 pitch, 20-core	357J-4674D: Main body 357J-4664N: Attachment
FX2c-I/O-CON-S for bulk wire	5-piece set	Housing HU-200S2-001 Solderless contact HU-411S	AWG22 (0.3mm ²)	357J-5538
FX2c-I/O-CON-SA for bulk wire	5-piece set	Housing HU-200S2-001 Solderless contact HU-411SA	AWG20 (0.5mm ²)	357J-13963
FX-I/O-CON2-S for bulk wire (40 Pin)	2-piece set	Housing HU-400S2-001 Solderless contact HU-411S	AWG22 (0.3mm ²)	357J-5538
FX-I/O-CON2-SA for bulk wire (40 Pin)	2-piece set	Housing HU-400S2-001 Solderless contact HU-411SA	AWG20 (0.5mm ²)	357J-13963

- Certified connectors (commercially available connectors)
Connectors made by DDK Ltd. shown in item 3).

9.2.3 Terminal block (for europe) [expansion board and special adapters]

WIRING PRECAUTIONS	 DANGER
<ul style="list-style-type: none"> • Make sure to cut off all phases of the power supply externally before attempting installation or wiring work. Failure to do so may cause electric shock or damage to the product. 	

WIRING PRECAUTIONS	 CAUTION
<ul style="list-style-type: none"> • Make sure to properly wire to the terminal block (European type) in accordance with the following precautions. Failure to do so may cause electric shock, equipment failures, a short-circuit, wire breakage, malfunctions, or damage to the product. <ul style="list-style-type: none"> - The disposal size of the cable end should follow the dimensions described in the manual. - Tightening torque should follow the specifications in the manual. - Twist the end of strand wire and make sure that there are no loose wires. - Do not solder-plate the electric wire ends. - Do not connect more than the specified number of wires or electric wires of unspecified size. - Affix the electric wires so that neither the terminal block nor the connected parts are directly stressed. 	

The expansion board and special adapters of a terminal block type have terminal blocks for Europe.

1. Applicable products

Classification	Model names
Expansion Board	FX3U-485-BD
Special Adapters	FX3U-485ADP(-MB), FX3U-4AD-ADP, FX3U-4DA-ADP, FX3U-3A-ADP, FX3U-4AD-PT-ADP, FX3U-4AD-PTW-ADP, FX3U-4AD-PNK-ADP, FX3U-4AD-TC-ADP, FX3U-4HSX-ADP, FX3U-2HSY-ADP

2. Compliant electric wires and tightening torque

	Electric wire size (stranded wire/solid wire)	Tightening torque	End treatment
One electric wire	0.3mm ² to 0.5mm ² (AWG22 to 20)	0.22 to 0.25N•m	<ul style="list-style-type: none"> • Remove the coating of the stranded wire, twist the core wires, and connect the wires directly. • Remove the coating from the solid wire, and connect the wire directly. • Bar terminal with insulating sleeve (recommended product) AI 0.5-8WH (Phoenix Contact) • Caulking tool CRIMPFOX 6^{*1} : Phoenix Contact (CRIMPFOX 6T-F^{*2} : Phoenix Contact)
Two electric wires	0.3mm ² (AWG22) × 2		
Bar terminal with insulating sleeve	0.3 mm ² to 0.5 mm ² (AWG22 to 20) (Refer to the following outline drawing of bar terminal.)		

*1. Old model name : CRIMPFOX ZA 3

*2. Old model name : CRIMPFOX UD 6

1	Introduction
2	Features and Part Names
3	Product Introduction
4	Specifications
5	Version and Peripheral Devices
6	System Configuration
7	Input/Output Nos., Unit Nos.
8	Installation
9	Preparation and Power Supply Wiring
10	Input Wiring

3. Treatment of electric wire ends

Treat the ends of stranded wires and solid wires without coating or using bar terminals with insulating sleeve. Tighten the terminals to a torque of 0.22 to 0.25 N•m.

Do not tighten terminal screws exceeding the specified torque. Failure to do so may cause equipment failures or malfunctions.

- Treatment of stranded wires and solid wires without coating
 - Twist the ends of stranded wires tightly so that loose wires will not stick out.
 - Do not solder-plate the electric wire ends.

- Treatment using bar terminal with insulating sleeve
It may be difficult to insert the electric wire into the insulating sleeve depending on the thickness of the electric wire sheath. Select the electric wire referring to the outline drawing.

<Reference>

Manufacturer	Model names	Caulking tool
Phoenix Contact	AI 0.5-8WH	CRIMPFOX 6*1 (or CRIMPFOX 6T-F*2)

*1. Old model name : CRIMPFOX ZA 3

*2. Old model name : CRIMPFOX UD 6

- Stranded wire/solid wire

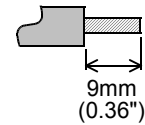

- Bar terminal with insulating sleeve

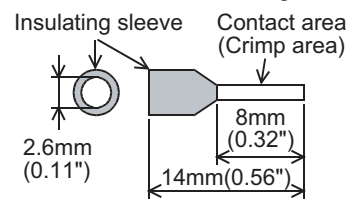

4. Tool

- For tightening the terminal, use a commercially available small screwdriver having a straight form that is not widened toward the end as shown right.

Note :

If the diameter of screwdriver grip is too small, tightening torque will not be able to be achieved. To achieve the appropriate tightening torque shown in the table on the previous page, use the following screwdriver or an appropriate replacement (grip diameter: approximately 25mm (0.98")).

<Reference>

Manufacturer	Model names
Phoenix Contact	SZS 0.4 x 2.5

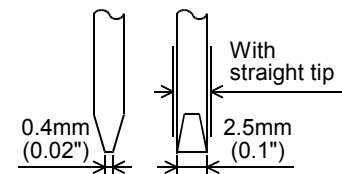

9.3 Power Supply Specifications

The specifications for power supply input to the main unit are explained below.

For the power consumption by the special function units/blocks, refer to this manual or the manual of each product.

9.3.1 AC Power Supply Type

Item	Specifications					
	FX3U-16M□/E□	FX3U-32M□/E□ FX3U-32MR/UA1	FX3U-48M□/E□	FX3U-64M□/E□ FX3U-64MR/UA1	FX3U-80M□/E□	FX3U-128M□
Supply voltage	100 to 240V AC					
Allowable supply voltage range	85 to 264V AC					
Rated frequency	50/60Hz					
Allowable instantaneous power failure time	Operation can be continued upon occurrence of instantaneous power failure for 10 ms or less. When the supply voltage is 200V AC, the time can be changed to 10 to 100 ms by editing the user program.					
Power fuse	250V, 3.15A ^{*5}		250V, 5A			
Rush current	30 A max. 5 ms or less/100V AC 65 A max. 5 ms or less/200V AC					
Power consumption ^{*1}	30W	35W	40W	45W	50W	65W
24V DC service power supply ^{*2*3}	400 mA or less		600 mA or less			
5V DC built-in power supply ^{*4}	500 mA or less					

- *1. These power consumption values are maximum values which apply to the main unit's 24V DC service power supply when there are input/output extension blocks and special function units/blocks.
→ **For input/output powered extension units/blocks power consumption information, refer to Section 15.2.**
- *2. When input/output extension blocks are connected, 24V DC service power is consumed by the blocks, and the power to be consumed by the main unit is reduced.
→ **For details on the 24V DC service power supply, refer to Section 6.5.**
- *3. 24V DC service power is not provided to FX3U-32MR/UA1 and FX3U-64MR/UA1.
- *4. The power supply is not for external use.
The current capacity specified above is for the input/output extension blocks, special function blocks, special adapters and expansion boards.
- *5. 250V 5A is specified for the power fuse of FX3U-32MR/UA1.

9.3.2 DC Power Supply Type

Item	Specifications				
	FX3U-16M□/D□	FX3U-32M□/D□	FX3U-48M□/D□	FX3U-64M□/D□	FX3U-80M□/D□
Supply voltage	24V DC				
Allowable supply voltage range	16.8 to 28.8V DC ^{*3}				
Allowable instantaneous power failure time	Operation can be continued upon occurrence of instantaneous power failure for 5 ms or less.				
Power fuse	250V, 3.15A		250V, 5A		
Power consumption ^{*1}	25W	30W	35W	40W	45W
Rush current	35 A max. 0.5 ms or less/24V DC				
24V DC service power supply	-				
5V DC built-in power supply ^{*2}	500 mA or less				

- *1. This power consumption is the value maximized by input/output extension blocks and special function units/blocks connected to the main unit.
 → **For input/output powered extension units/blocks power consumption information, refer to Section 15.2.**
- *2. The power supply is not for external use.
 The current capacity specified above is for the input/output extension blocks, special function blocks, special adapters and expansion boards.
- *3. When supply voltage is 16.8 to 19.2V DC, the connectable extension equipment decreases.
 For details, refer to Subsection 6.5.3 or 6.5.4.

9.4 Grounding

Ground the PLC as stated below.

- Perform class D grounding. (Grounding resistance: 100Ω or less)
- Ground the PLC independently if possible.
If it cannot be grounded independently, ground it jointly as shown below.

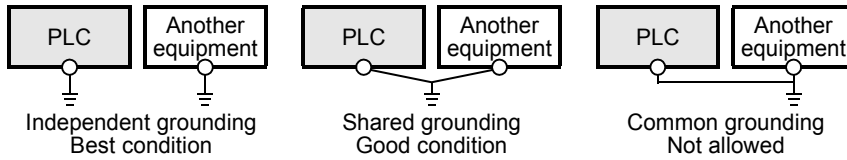

Extension devices of PLC (except expansion board and special communication/high-speed input/output adapter)

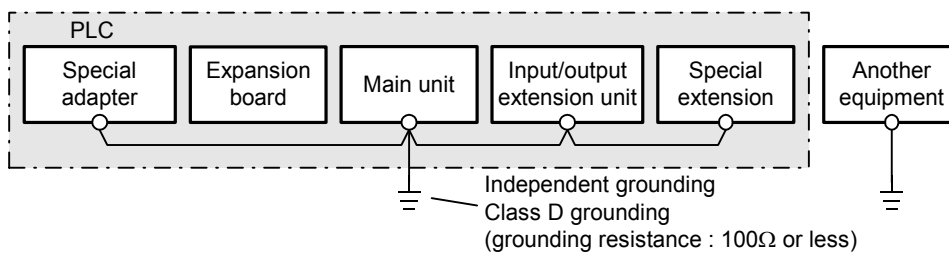

- Use ground wires thicker than AWG14 (2 mm²).
- Position the grounding point as close to the PLC as possible to decrease the length of the ground wire.

9.5 Examples of External Wiring [AC Power Supply/DC Input Type]

9.5.1 Example of input/output wiring with 24V DC service power supply

24V DC service power supply of the main unit can be used as a power supply for loads. However, the power consumed by extension devices should be subtracted from the 24V DC service power, and the remainder can be used as power for loads.

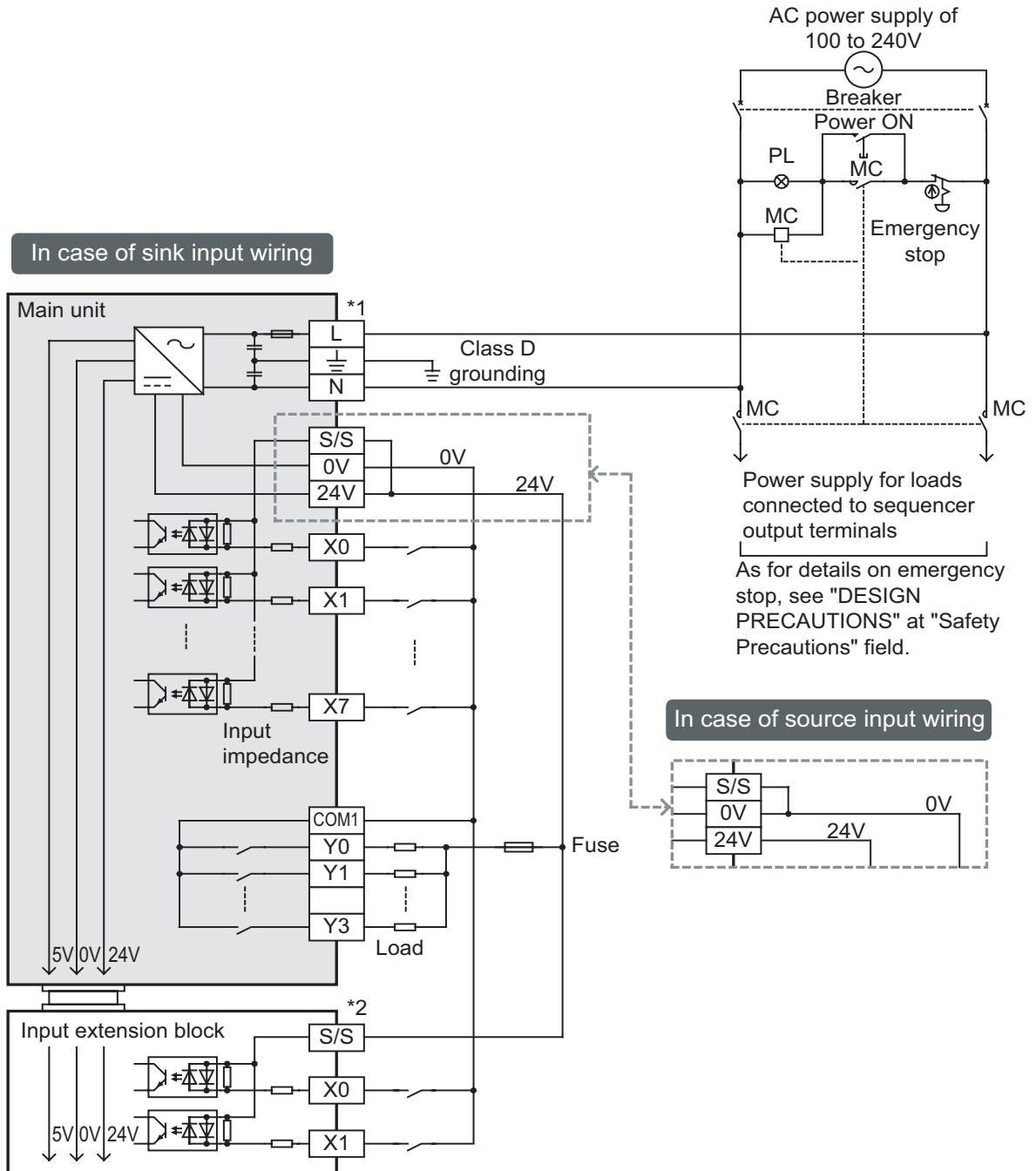

*1 Connect the AC power supply to the L and N terminals (in any case of 100V AC system and 200V AC system). As for details, see "WIRING PRECAUTIONS" at "Safety Precautions" field.

*2 Connect the 24V terminal (in case of sink input) or the 0V terminal (in case of source input) to the S/S terminal on the input extension block.

9.5.2 Example of sink input [-common] wiring

An example of sink input [-common] wiring is given below. When connecting input/output powered extension units/blocks, carefully check the signal names on the terminal block because the sink and source input type units/blocks and the sink input type units/blocks vary in signal names on the terminal block.

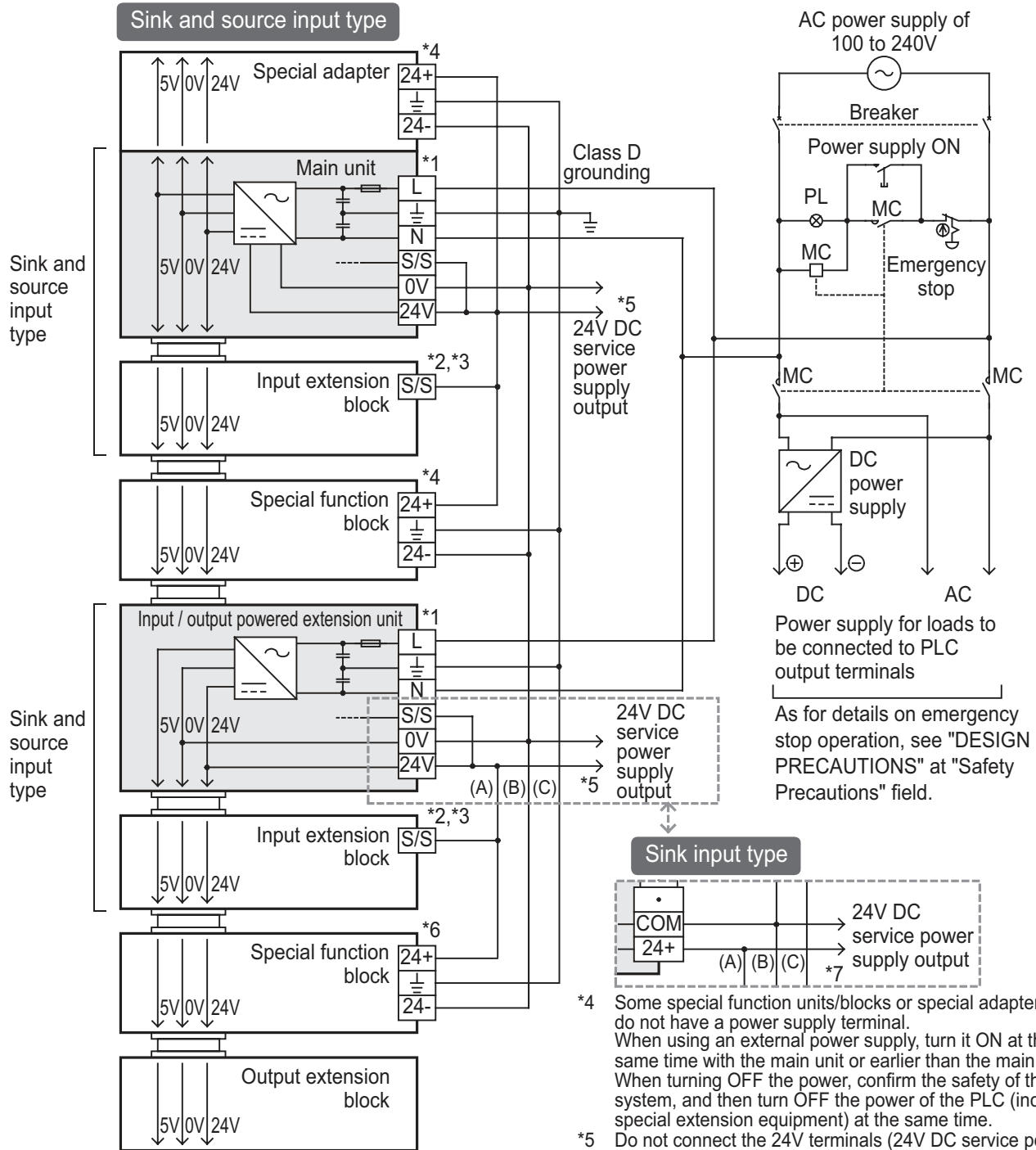

- *1 Connect the AC power supply to the L and N terminals (in any case of 100V AC system and 200V AC system). Make sure that the power is turned ON at the same time in the main unit and extension units or earlier in extension units than the main unit. For details, refer to "WIRING PRECAUTIONS" in "Safety Precautions". As for details, see "WIRING PRECAUTIONS" at "Safety Precautions" field.
- *2 Connect the 24V terminal of the main unit or the input/output extension unit to the S/S terminal of the input extension block.
- *3 In case of the sink input type, the S/S terminal is used as the 24+ terminal.

- *4 Some special function units/blocks or special adapters do not have a power supply terminal. When using an external power supply, turn it ON at the same time with the main unit or earlier than the main unit. When turning OFF the power, confirm the safety of the system, and then turn OFF the power of the PLC (including special extension equipment) at the same time.
- *5 Do not connect the 24V terminals (24V DC service power supply) of the main unit and the input/output extension unit with each other. Connect the 0V terminal.
- *6 Some special extension units/blocks do not have power terminals. When using an external power supply, turn it ON at the same time with the extension unit or earlier than the extension unit. When turning OFF the power, confirm the safety of the system, and then turn OFF the power of the PLC (including special extension equipment) at the same time.
- *7 Do not connect the 24V terminal of the main unit to the 24+ terminal (24V DC service power supply) of an input/output extension unit. Connect the 0V terminal to the COM terminal.

1	Introduction
2	Features and Part Names
3	Product Introduction
4	Specifications
5	Version and Peripheral Devices
6	System Configuration
7	Input/Output Nos., Unit Nos.
8	Installation
9	Preparation and Power Supply Wiring
10	Input Wiring

9.5.3 Example of source input [+common] wiring

An example of source input [+common] wiring is shown below.

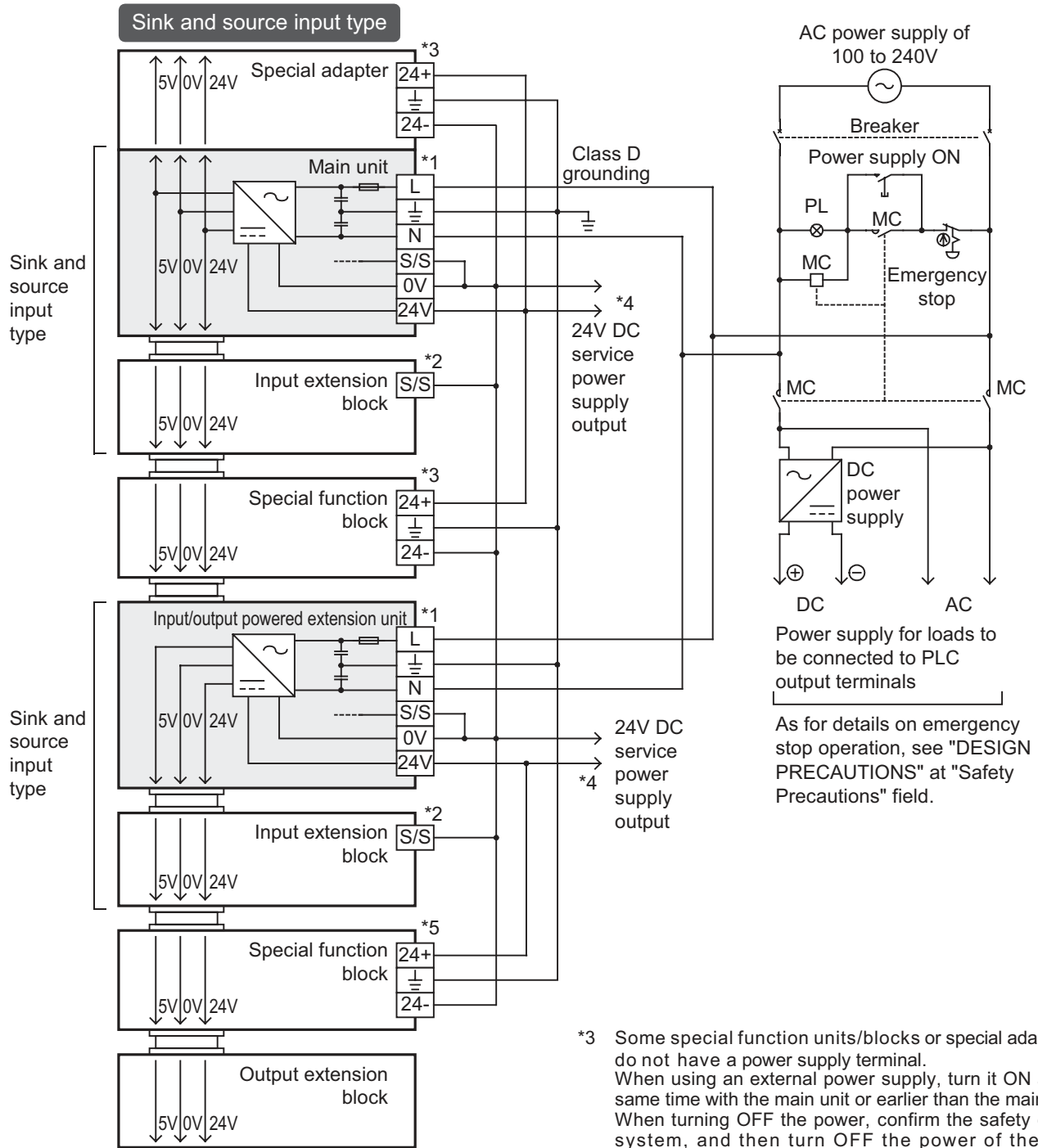

- *1 Connect the AC power supply to the L and N terminals (in any case of 100V AC system and 200V AC system). Make sure that the power is turned ON at the same time in the main unit and extension units or earlier in extension units than the main unit. For details, refer to "WIRING PRECAUTIONS" in "Safety Precautions" As for details, see "WIRING PRECAUTIONS" at "Safety Precautions" field.
- *2 Connect the 0V terminal of the main unit or extension unit to the S/S terminal of the input extension block.

- *3 Some special function units/blocks or special adapters do not have a power supply terminal. When using an external power supply, turn it ON at the same time with the main unit or earlier than the main unit. When turning OFF the power, confirm the safety of the PLC (including special extension equipment) at the same time.
- *4 Do not connect the 24V terminals (24V DC service power supply) of the main unit and the input/output extension unit with each other. Connect the 0V terminal.
- *5 Some special extension units/blocks do not have power terminals. When using an external power supply, turn it ON at the same time with the extension unit or earlier than the extension unit. When turning OFF the power, confirm the safety of the system, and then turn OFF the power of the PLC (including special extension equipment) at the same time.

9.5.4 An external wiring example for the extension power supply unit (sink input [-common])

This example shows a sink input wiring (-common), including the extension power supply unit. When adding an input extension block, check the signal name on the terminal block since the sink/source type and sink type differ from each other.

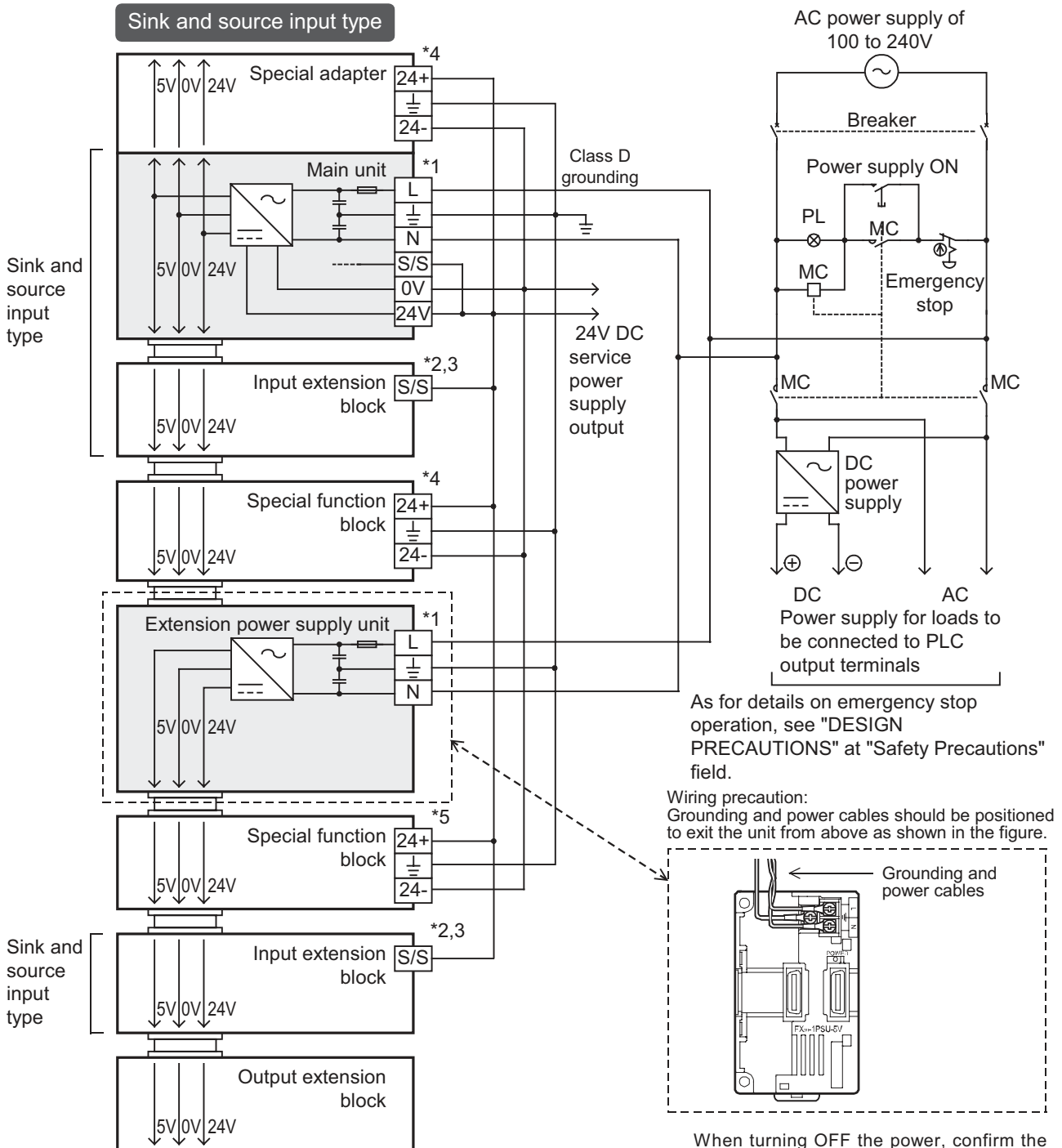

- *1 Connect the AC power supply to the L and N terminals (in any case of 100V AC system and 200V AC system). Make sure that the power is turned ON at the same time in the main unit and extension power supply units or earlier in extension power supply units than the main unit. As for details, see "WIRING PRECAUTIONS" at "Safety Precautions" field.
- *2 Connect the 24V terminal of the main unit to the S/S terminal of the input extension block.
- *3 In case of the sink input type, the S/S terminal is used as the 24+ terminal.
- *4 Some special function units/blocks or special adapters do not have a power supply terminal. When using an external power supply, turn it ON at the same time with the main unit or earlier than the main unit.

As for details on emergency stop operation, see "DESIGN PRECAUTIONS" at "Safety Precautions" field.

Wiring precaution:
Grounding and power cables should be positioned to exit the unit from above as shown in the figure.

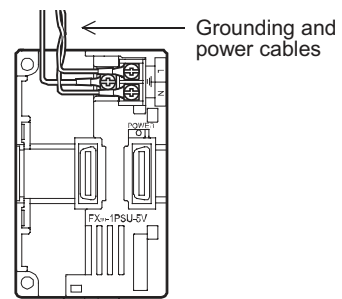

When turning OFF the power, confirm the safety of the system, and then turn OFF the power of the PLC (including special extension equipment) at the same time. Some special function units/blocks do not have a power supply terminals. When using an external power supply, turn it ON at the same time with the extension power supply unit or earlier than the extension power supply unit. When turning OFF the power, confirm the safety of the system, and then turn OFF the power of the PLC (including special extension equipment) at the same time.

1	Introduction
2	Features and Part Names
3	Product Introduction
4	Specifications
5	Version and Peripheral Devices
6	System Configuration
7	Input/Output Nos., Unit Nos.
8	Installation
9	Preparation and Power Supply Wiring
10	Input Wiring

9.5.5 An external wiring example for the extension power supply unit (source input [+common])

This example shows a source input wiring (+common), including the extension power supply unit.

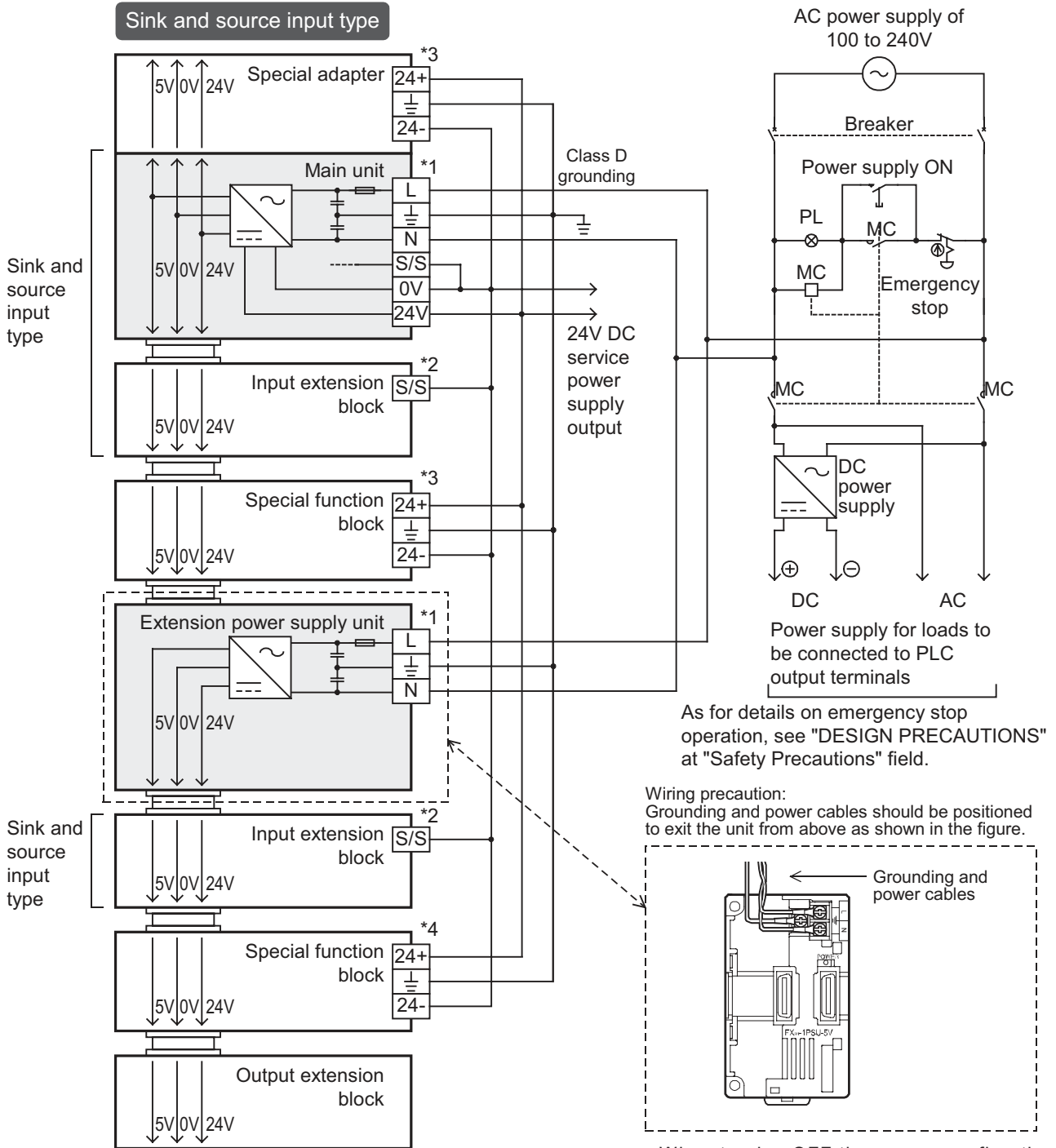

- *1 Connect the AC power supply to the L and N terminals (in any case of 100V AC system and 200V AC system). Make sure that the power is turned ON at the same time in the main unit and extension power supply units or earlier in extension power supply units than the main unit. As for details, see "WIRING PRECAUTIONS" at "Safety Precautions" field.
- *2 Connect the 0V terminal of the main unit to the S/S terminal of the input extension block.
- *3 Some special function units/blocks or special adapters do not have a power supply terminal. When using an external power supply, turn it ON at the same time with the main unit or earlier than the main unit.

- *4 Some special function units/blocks do not have a power supply terminals. When using an external power supply, turn it ON at the same time with the extension power supply unit or earlier than the extension power supply unit. When turning OFF the power, confirm the safety of the system, and then turn OFF the power of the PLC (including special extension equipment) at the same time.

9.6 Examples of External Wiring [DC Power Supply/DC Input Type]

9.6.1 Example of sink input [-common] wiring

An example of sink input [-common] wiring is given below. When connecting input/output powered extension units/blocks, carefully check the signal names on the terminal block because the sink and source input type units/blocks and the sink input type units/blocks vary in signal names on the terminal block.

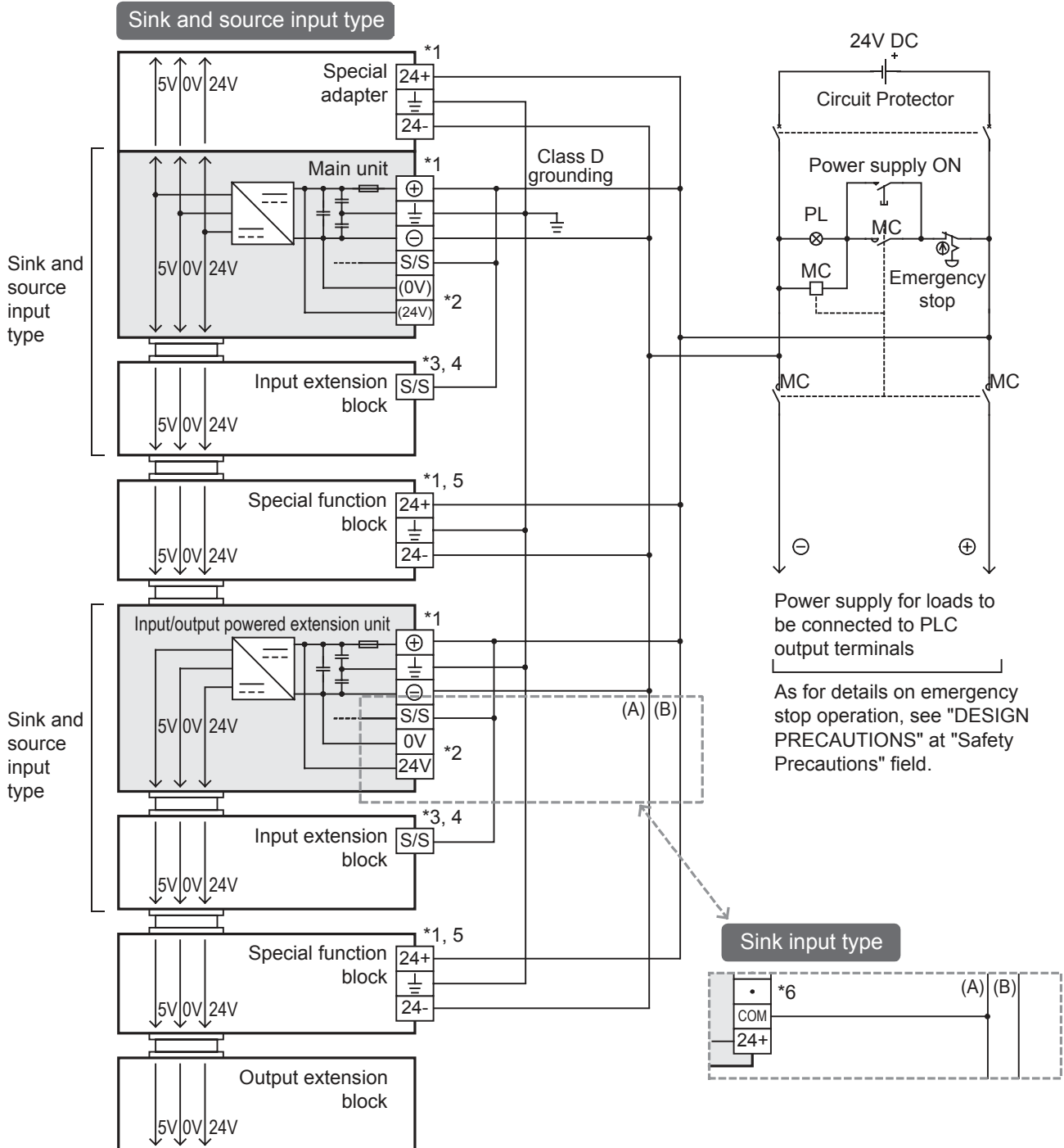

- *1 Connect DC power to [+] and [-] terminals. The same power source for the main unit, extension units, special function unit/blocks and special adapters is preferable. When using the different power source from the main unit, turn ON the peripheral devices' power simultaneously, or earlier than the main unit's. When turning OFF the power, confirm the safety of the system and then turn OFF the power of the PLC (including special extension equipment) at the same time.
- *2 Do not connect with [0V] and [24V] terminals.

- *3 24V DC [+] supplies power to the [S/S] terminal at the input extension block.
- *4 In case of the sink input type, the [S/S] terminal is used as the [24+] terminal.
- *5 Some special function units/blocks do not have a power supply terminal.
- *6 Do not connect with [24+] and [·] terminals.

1	Introduction
2	Features and Part Names
3	Product Introduction
4	Specifications
5	Version and Peripheral Devices
6	System Configuration
7	Input/Output Nos., Unit Nos.
8	Installation
9	Preparation and Power Supply Wiring
10	Input Wiring

9.6.2 Example of source input [+common] wiring

An example of source input [+common] wiring is shown below.

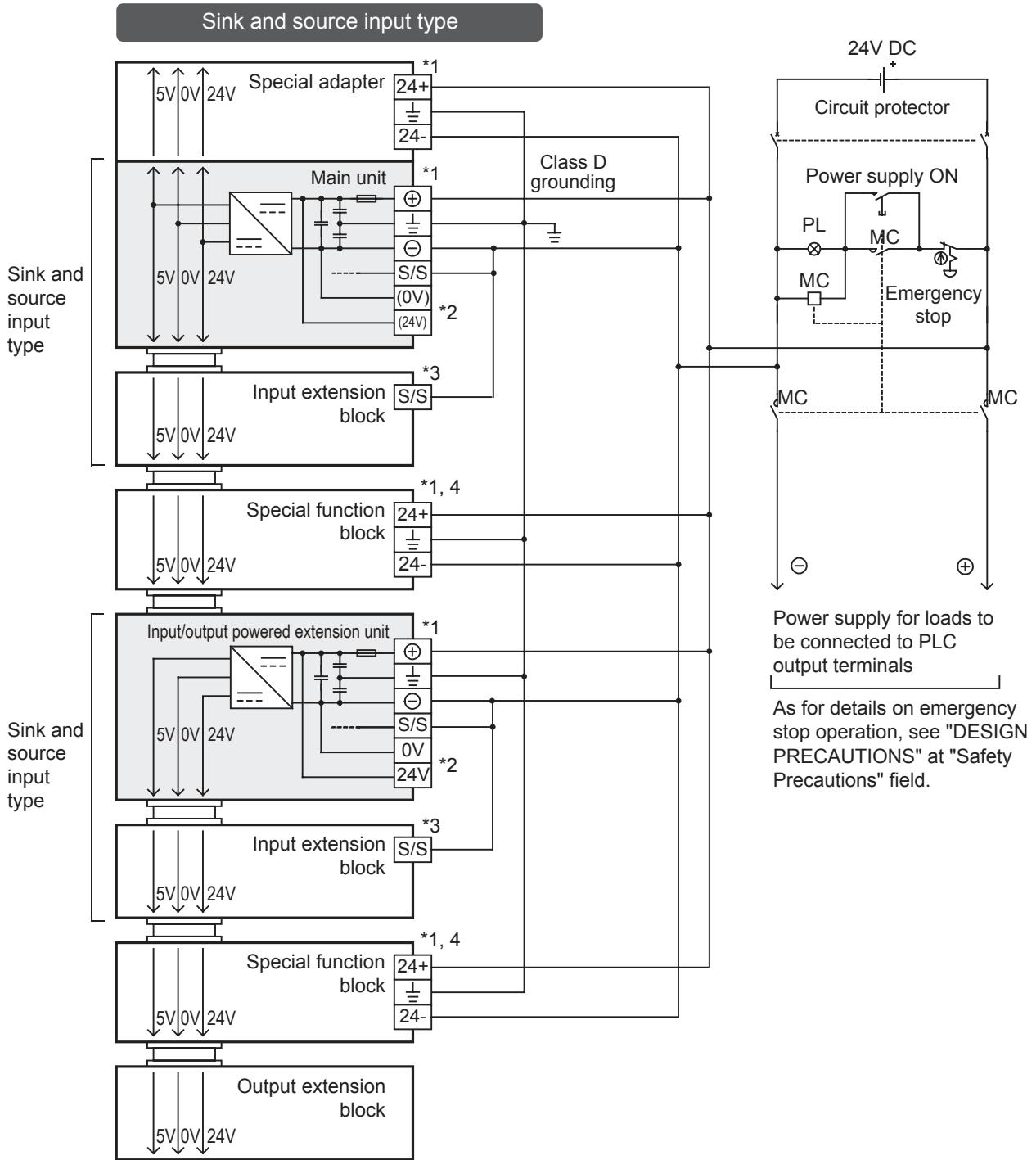

9.7 Examples of External Wiring [AC Power Supply/AC Input Type]

9.7.1 Example of AC input wiring

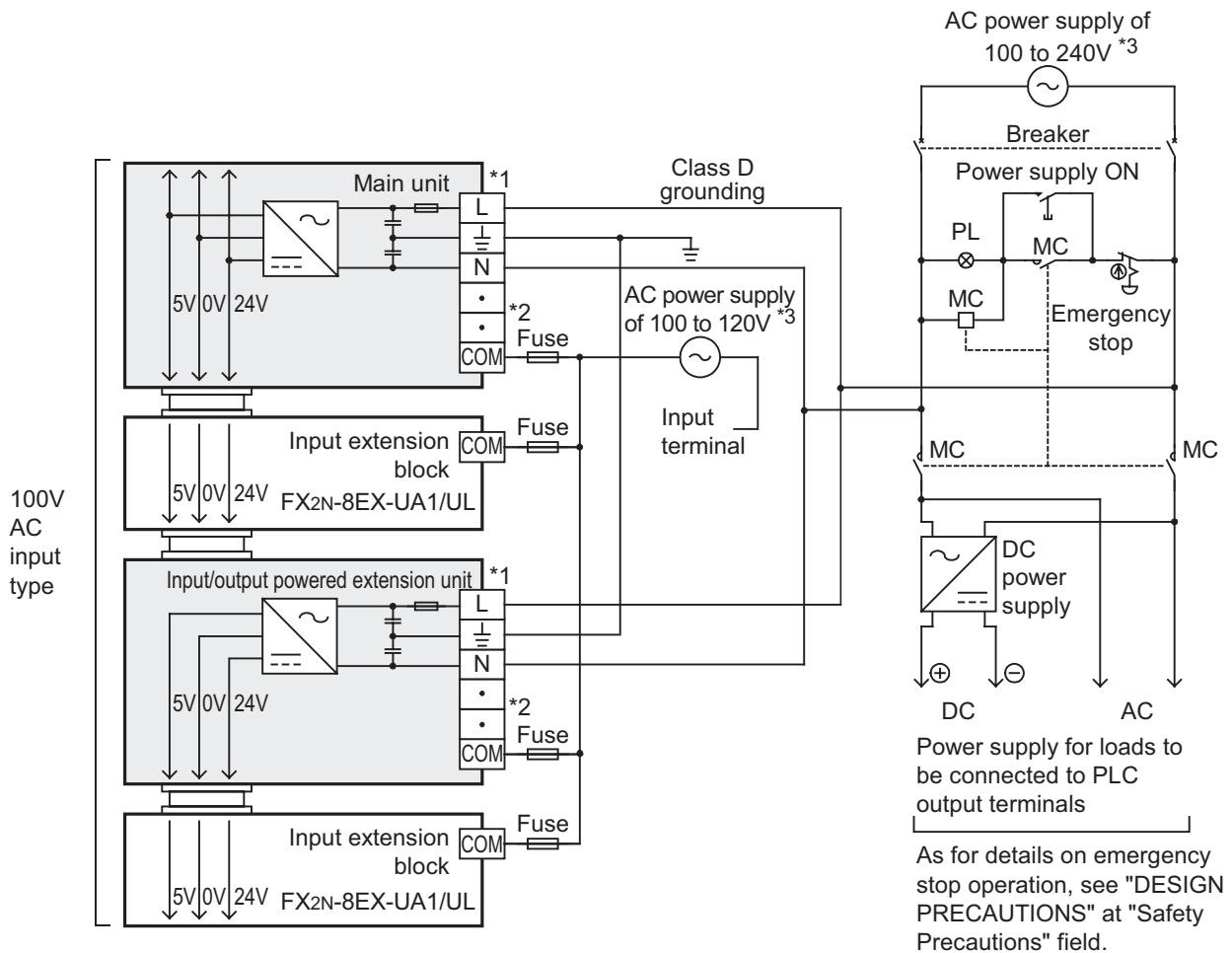

*1 Connect the AC power supply to the L and N terminals (in any case of 100V AC system and 200V AC system). Make sure that the power is turned ON at the same time in the main unit and extension units or earlier in extension units than the main unit.
As for details, see "WIRING PRECAUTIONS" at "Safety Precautions" field.

*2 Do not connect with [·] terminal.

*3 The input specification is 100V to 120V AC even though the power supply voltage specification of main unit and input/output extension unit is 100V to 240V AC.

1

Introduction

2

Features and Part Names

3

Product Introduction

4

Specifications

5

Version and Peripheral Devices

6

System Configuration

7

Input/Output Nos., Unit Nos.

8

Installation

9

Preparation and Power Supply Wiring

10

Input Wiring

10. Input Wiring Procedures (Input Interruption and Pulse Catch)

DESIGN PRECAUTIONS



DANGER

- Make sure to have the following safety circuits outside of the PLC to ensure safe system operation even during external power supply problems or PLC failure.
Otherwise, malfunctions may cause serious accidents.
 - 1) Most importantly, have the following: an emergency stop circuit, a protection circuit, an interlock circuit for opposite movements (such as normal vs. reverse rotation), and an interlock circuit (to prevent damage to the equipment at the upper and lower positioning limits).
 - 2) Note that when the PLC CPU detects an error, such as a watchdog timer error, during self-diagnosis, all outputs are turned off. Also, when an error that cannot be detected by the PLC CPU occurs in an input/output control block, output control may be disabled.
External circuits and mechanisms should be designed to ensure safe machinery operation in such a case.
 - 3) Note that the output current of the 24V DC service power supply varies depending on the model and the absence/presence of extension blocks. If an overload occurs, the voltage automatically drops, inputs in the PLC are disabled, and all outputs are turned off.
External circuits and mechanisms should be designed to ensure safe machinery operation in such a case.
 - 4) Note that when an error occurs in a relay, triac or transistor output device, the output could be held either on or off.
For output signals that may lead to serious accidents, external circuits and mechanisms should be designed to ensure safe machinery operation in such a case.

DESIGN PRECAUTIONS



CAUTION

- Do not bundle the control line together with or lay it close to the main circuit or power line. As a guideline, lay the control line at least 100mm (3.94") or more away from the main circuit or power line.
Noise may cause malfunctions.
- Install module so that excessive force will not be applied to peripheral device connectors.
Failure to do so may result in wire damage/breakage or PLC failure.

WIRING PRECAUTIONS



DANGER

- Make sure to cut off all phases of the power supply externally before attempting installation or wiring work.
Failure to do so may cause electric shock or damage to the product.
- Make sure to attach the terminal cover, offered as an accessory, before turning on the power or initiating operation after installation or wiring work.
Failure to do so may cause electric shock.

WIRING PRECAUTIONS



- Do not supply power to the [24+] and [24V] terminals (24V DC service power supply) on the main unit or extension units.
Doing so may cause damage to the product.
- Perform class D grounding (grounding resistance: 100 Ω or less) to the grounding terminal on the main unit and extension units with a wire 2 mm² or thicker.
Do not use common grounding with heavy electrical systems (refer to Section 9.4).
- Connect the AC power supply wiring to the dedicated terminals described in this manual.
If an AC power supply is connected to a DC input/output terminal or DC power supply terminal, the PLC will burn out.
- Connect the DC power supply wiring to the dedicated terminals described in this manual.
If an AC power supply is connected to a DC input/output terminal or DC power supply terminal, the PLC will burn out.
- Do not wire vacant terminals externally.
Doing so may damage the product.
- When drilling screw holes or wiring, make sure that cutting and wiring debris do not enter the ventilation slits.
Failure to do so may cause fire, equipment failures or malfunctions.
- Make sure to properly wire the FX3U Series main unit and FX0N/FX2N/FX3U Series extension equipment in accordance with the following precautions.
Failure to do so may cause electric shock, equipment failures, a short-circuit, wire breakage, malfunctions, or damage to the product.
 - The disposal size of the cable end should follow the dimensions described in the manual.
 - Tightening torque should follow the specifications in the manual.
- Make sure to properly wire to the terminal block (European type) in accordance with the following precautions.
Failure to do so may cause electric shock, equipment failures, a short-circuit, wire breakage, malfunctions, or damage to the product.
 - The disposal size of the cable end should follow the dimensions described in the manual.
 - Tightening torque should follow the specifications in the manual.
 - Twist the end of strand wire and make sure that there are no loose wires.
 - Do not solder-plate the electric wire ends.
 - Do not connect more than the specified number of wires or electric wires of unspecified size.
 - Affix the electric wires so that neither the terminal block nor the connected parts are directly stressed.
- Make sure to properly wire to the FX Series terminal blocks in accordance with the following precautions.
Failure to do so may cause electric shock, equipment failures, a short-circuit, wire breakage, malfunctions, or damage to the product.
 - The disposal size of the cable end should follow the dimensions described in the manual.
 - Tightening torque should follow the specifications in the manual.

This chapter explains the followings.

- Sink/source input (24V DC input)
- Input specifications (main unit), instructions for wiring and examples of external wiring
- Input interruption function
- Pulse catch function

1	Introduction
2	Features and Part Names
3	Product Introduction
4	Specifications
5	Version and Peripheral Devices
6	System Configuration
7	Input/Output Nos., Unit Nos.
8	Installation
9	Preparation and Power Supply Wiring
10	Input Wiring

10.1 Before Starting Input Wiring

10.1.1 Sink and source input (24V DC input type)

The input terminals (X) of the main unit are common to sink/source input of 24V DC internal power. FX2N Series input/output powered extension units/blocks have input terminals common to sink/source input or only for sink input.

1. Difference between circuits

- Sink input [-common]
Sink input means a DC input signal with current-flow from the input (X) terminal.
When a sensor with a transistor output is connected, NPN open collector transistor output can be used.

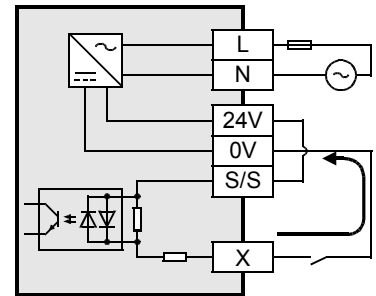

- Source input [+common]
Source input means a DC input signal with current-flow into the input (X) terminal.
When a sensor with a transistor output is connected, PNP open collector transistor output can be used.

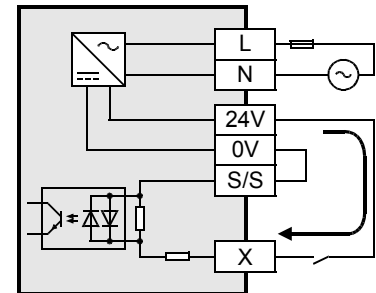

2. Method of switching between sink/source input

To switch the input type to sink or source input, wire the S/S terminal to the 0V or 24V (+ or -) terminal.

- 1) In case of AC power supply type
 - Sink input: [24V] terminal and [S/S] terminal are connected.
 - Source input: [0V] terminal and [S/S] terminal are connected.
→ Refer to Subsection 10.2.4 and 10.2.5 for wiring examples.
- 2) In case of DC power supply type
 - Sink input: [\oplus] terminal and [S/S] terminal are connected.
 - Source input: [\ominus] terminal and [S/S] terminal are connected.
→ Refer to Subsection 10.2.6 and 10.2.7 for wiring examples.

3. Instructions for using

- Concurrent use of sink/source input
It is possible to set all input terminals (X) of the main unit to the sink input mode or the source input mode. However, sink and source input terminals cannot be used concurrently.
 - The main unit and input/output powered extension units are individually set to the sink or source input mode.
 - The input mode of an input/output extension block is determined according to the selection of the sink or source input mode on the powered extension unit (power source).
- Caution in selecting model
A type common to sink/source input and a type only for sink input are both available. Select a proper type.

Differences from FX2N PLCs in input specifications (reference)

FX2N PLCs only for sink input (manuals in Japanese are supplied) and those common to sink/source input (manuals in English are supplied) have different model names.

- In FX2N PLCs only for sink input, the S/S terminal and the 24V terminal are connected unlike in FX3U PLCs. When replacing a sink input type only FX2N PLC with a FX3U PLC, short-circuit the [S/S] and [24V] terminals, and use the [0V] terminal of the FX3U as the [COM] terminal of the FX2N for wiring.
- FX2N PLCs common to sink/source input are switched to the sink or source input mode by external wiring like FX3U PLCs.

10.2 24V DC Input Type (Common to Sink/Source Input)

The input specifications for the main unit, cautions on wiring the unit and examples of wiring are given below.

10.2.1 Input specifications (main unit)

The input numbers in the table indicate the main unit terminal numbers. "X010 or more" means the numbers from X010 to the largest number that the main unit has.
(The input numbers of FX3U-16M□ are X000 to X007.)

→ For details on sink/source input, refer to Subsection 10.1.1.

Item	Specifications					
	FX3u-16M□	FX3u-32M□ /□S(S)	FX3u-48M□	FX3u-64M□ /□S(S)	FX3u-80M□	FX3u-128M□
Number of input points	8 points	16 points	24 points	32 points	40 points	64 points
Input connecting type	Fixed terminal block (M3 screw)	Removable terminal block (M3 screw)				
Input form	sink/source					
Input signal voltage	AC power type: 24V DC ±10% DC power type: 16.8 to 28.8V DC					
Input impedance	X000 to X005	3.9 kΩ				
	X006, X007	3.3 kΩ				
	X010 or more	–	4.3 kΩ			
Input signal current	X000 to X005	6 mA/24V DC				
	X006, X007	7 mA/24V DC				
	X010 or more	–	5 mA/24V DC			
ON input sensitivity current	X000 to X005	3.5 mA or more				
	X006, X007	4.5 mA or more				
	X010 or more	–	3.5 mA or more			
OFF input sensitivity current	1.5 mA or less					
Input response time	Approx. 10 ms					
Input signal form	No-voltage contact input Sink input: NPN open collector transistor Source input: PNP open collector transistor					
Input circuit insulation	Photocoupler insulation					
Input operation display	LED on panel lights when photocoupler is driven.					

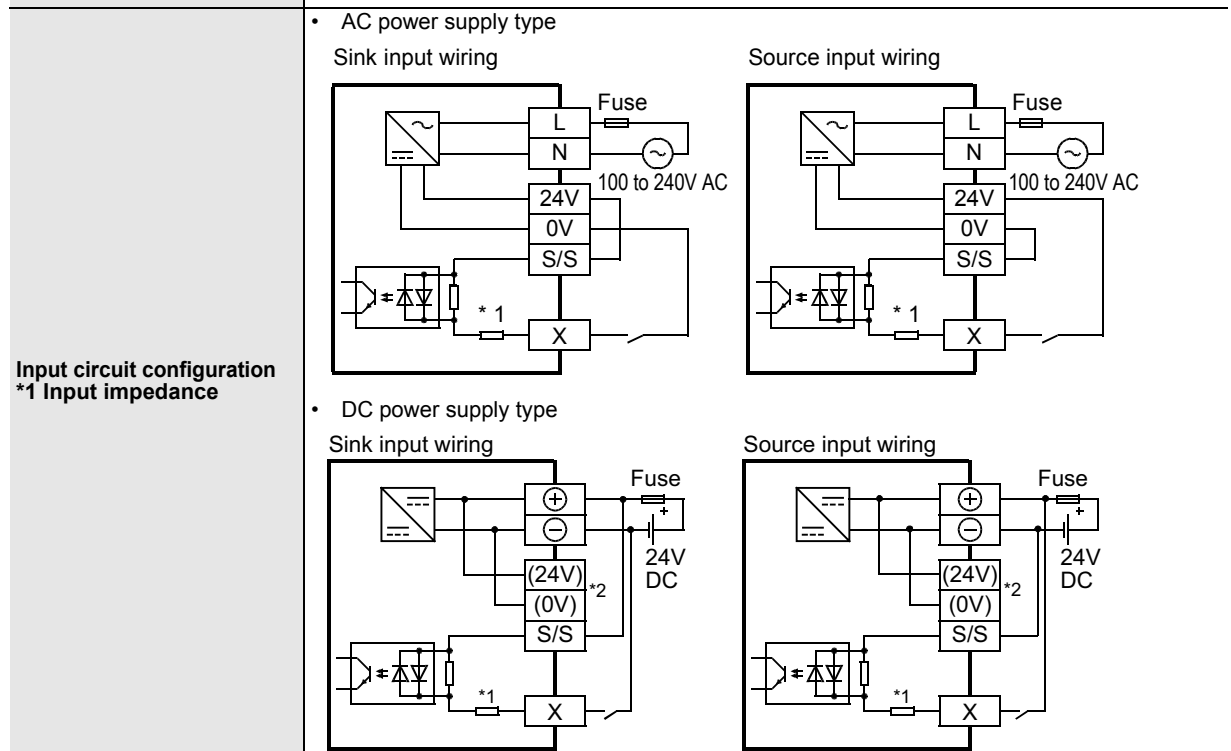

*2. Do not connect with (0V) and (24V) terminals.

10.2.2 Handling of 24V DC input

1. Input terminals

Sink input

When a no-voltage contact or NPN open collector transistor output is connected between an input (X) terminal and the 0V terminal and the circuit is closed, the input (X) turns on. Then, the input display LED is lit.

Source input

When a no-voltage contact or PNP open collector transistor output is connected between an input (X) terminal and the 24V terminal and the circuit is closed, the input (X) turns on. Then, the input display LED is lit.

Display module (option)

When the display module is mounted, the ON/OFF status can be checked on the LCD display.

RUN terminal setting

X000 to X017 (up to the largest input number in the main unit*1) of the main unit can be used as RUN input terminals by setting parameters.

*1. The FX3U-16M□ main unit input range is X000 to X007.

→ For the functions of the RUN terminals, refer to Subsection 14.2.1.

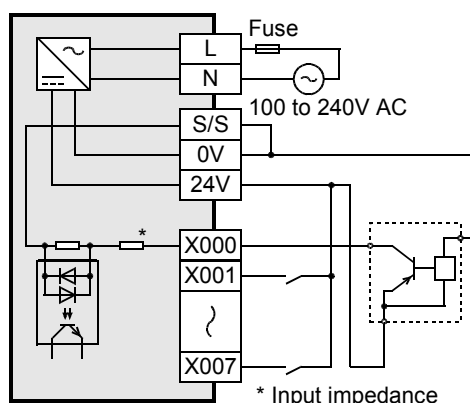
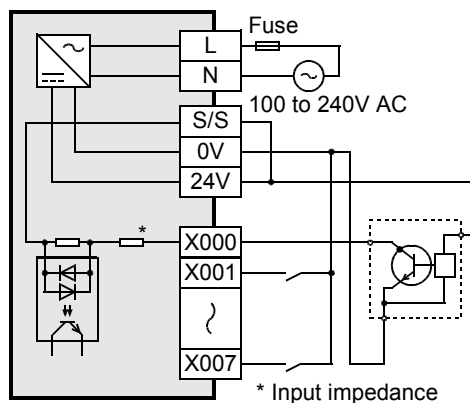

2. Input circuit

Function of input circuit

The primary and secondary circuits for input are insulated with a photocoupler, and the second circuit is provided with a C-R filter.

The C-R filter is designed to prevent malfunctions caused by chattering of the input contact and noise from the input line.

There is a delay of approx. 10ms in response to input-switching from ON to OFF and from OFF to ON.

Change of filter time

X000 to X017 (up to the largest number in the main unit) have digital filters, and the filter time can be changed in increments of 1ms in the range from 0 to 60ms through applied instructions. When 0 is specified for the time, the input filter values are set as shown in the following table.

Input number	Input filter value when 0 is specified	Remarks
X000 to X005	5 μ s ^{*1}	—
X006, X007	50 μ s	—
X010 to X017 ^{*2}	200 μ s	Except for the FX3U-16M□

*1. When the circuit is used at an input filter value of 5 μ s, be careful when wiring. (The details are stated later.)

*2. The FX3U-16M□ main unit input range is X000 to X007.

The filter time for input numbers X010 to X017 is kept 10 ms because the input filters of the input/output powered extension units/blocks are used for them.

Cautions on wiring when changing filter time

When setting the input filter to 5μs or capturing pulses of a response frequency of 50 to 100kHz with a high-speed counter, wire the terminals as stated below.

- 1) The wiring length should be 5m or less.
- 2) Connect a bleeder resistance of 1.5kΩ (1 W or more) to the input terminal, so that the sum of the load current of the open collector transistor output on the mating device and the input current of the main body is 20 mA or more.

3. Input sensitivity

The PLC input current and input sensitivity are shown in the following table. When there is a series diode or resistance at the input contact or there is a parallel resistance or leakage current at the input contact, wire the terminals according to the following table.

→ For the instructions for connecting input devices, refer to Subsection 10.2.3.

Item		X000 to X005	X006 to X007	X010 to max input number of the main unit
Input voltage		AC power type: 24V DC ±10% DC power type: 16.8 to 28.8V DC		
Input current		6 mA	7 mA	5 mA
Input sensitivity current	ON	3.5 mA or more	4.5 mA or more	3.5 mA or more
	OFF	1.5 mA or less	1.5 mA or less	1.5 mA or less

4. Examples of input wiring

For the wiring of input interruption, pulse catch and rotary encoder, refer to the following sections.

- Example of wiring of input interruption: Refer to Section 10.4.
- Example of wiring of pulse catch: Refer to Section 10.5.
- Example of wiring of rotary encoder: Refer to Section 11.10.

10.2.3 Instructions for connecting input devices

1. In case of no-voltage contact

The input current of this PLC is 5 to 7 mA/24V DC. Use input devices applicable to this minute current. If no-voltage contacts (switches) for large current are used, contact failure may occur.

Input number	Input current
X000 to X005	6 mA/24V DC
X006, X007	7 mA/24V DC
X010 or more	5 mA/24V DC

<Example> Products of OMRON

Type	Model name
Microswitch	Models Z, V and D2RV
Proximity switch	Model TL

Type	Model name
Operation switch	Model A3P
Photoelectric switch	Model E3S

2. In case of input device with built-in series diode

The voltage drop of the series diode should be approx. 4V or less. When lead switches with a series LED are used, up to two switches can be connected in series. Also make sure that the input current is over the input-sensing level while the switches are ON.

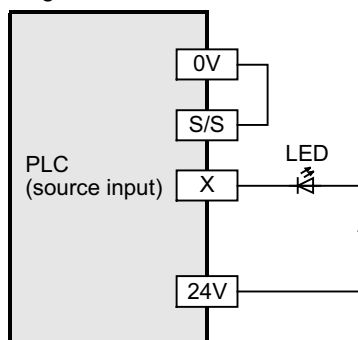
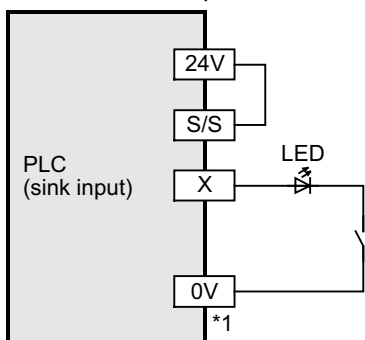

*1 In case of a type only for sink input, connect the device to the COM terminal.

1 Introduction
2 Features and Part Names
3 Product Introduction
4 Specifications
5 Version and Peripheral Devices
6 System Configuration
7 Input/Output Nos., Unit Nos.
8 Installation
9 Preparation and Power Supply Wiring
10 Input Wiring

3. In case of input device with built-in parallel resistance

Use a device with a parallel resistance, R_p , of 15k Ω or more.

If the resistance is less than 15k Ω , connect a bleeder resistance, R_b , obtained by the following formula as shown in the following figure.

$$R_b \leq \frac{4R_p}{15-R_p} \text{ (k}\Omega\text{)}$$

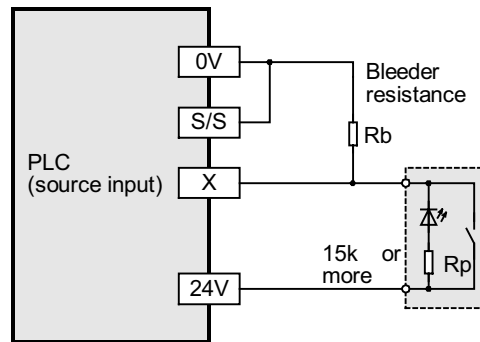
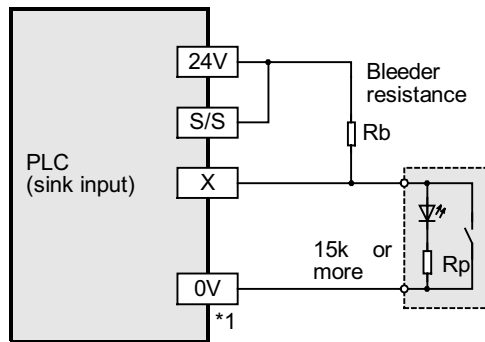

*1 In case of a type only for sink input, connect the device to the COM terminal.

4. In case of 2-wire proximity switch

Use a two-wire proximity switch whose leakage current, I_l , is 1.5 mA or less when the switch is off.

When the current is 1.5 mA or more, connect a bleeder resistance, R_b , determined by the following formula as shown in the following figure.

$$R_b \leq \frac{6}{I_l - 1.5} \text{ (k}\Omega\text{)}$$

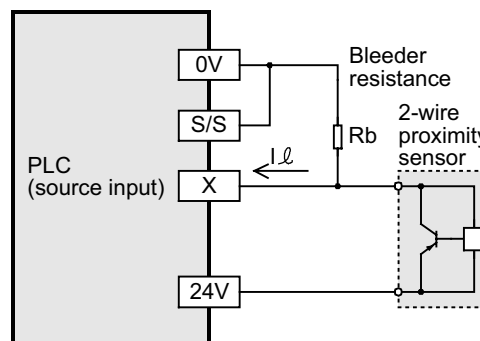
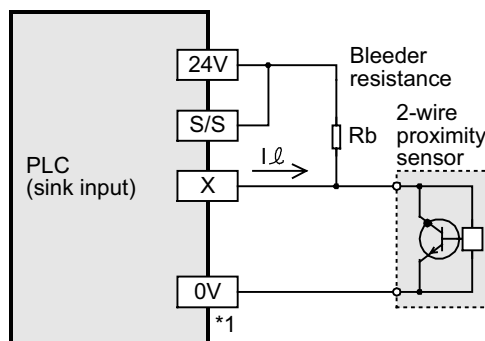

*1 In case of a type only for sink input, connect the device to the COM terminal.

10.2.4 Examples of external wiring (sink input) [AC Power Supply Type]

Sink and source input type

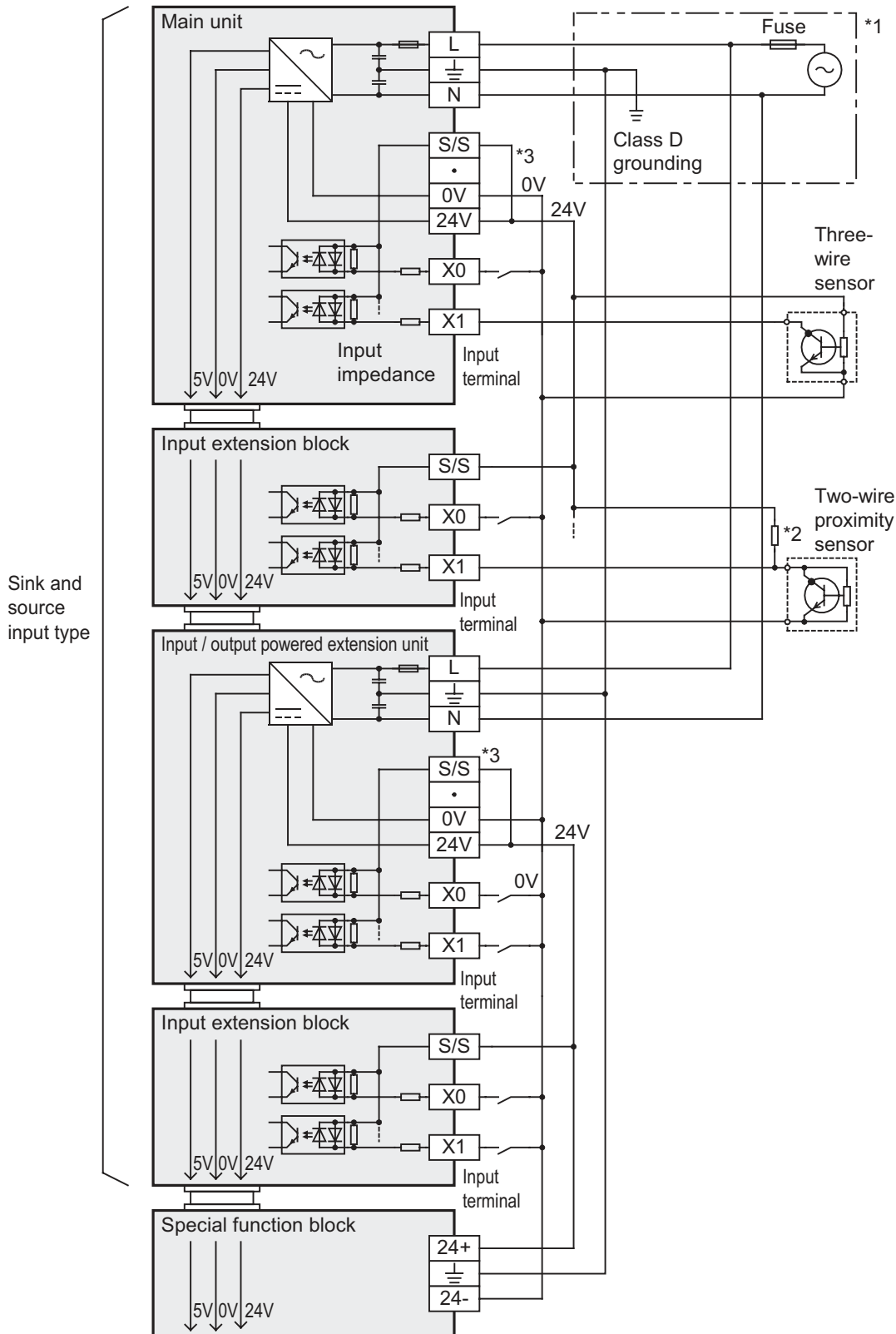

*1 Handle the power supply circuit correctly according to Chapter 9 "Preparation for Wiring and Power Supply Wiring Procedures."

*2 For an input device with a parallel resistance or a two-wire proximity switch, a bleeder resistance may be required.

*3 In case of sink input wiring, short-circuit the terminals of the extension units as well as the S/S terminal and the 24V terminal of the main unit.

1	Introduction
2	Features and Part Names
3	Product Introduction
4	Specifications
5	Version and Peripheral Devices
6	System Configuration
7	Input/Output Nos., Unit Nos.
8	Installation
9	Preparation and Power Supply Wiring
10	Input Wiring

Use of input/output extension units/blocks of sink input type

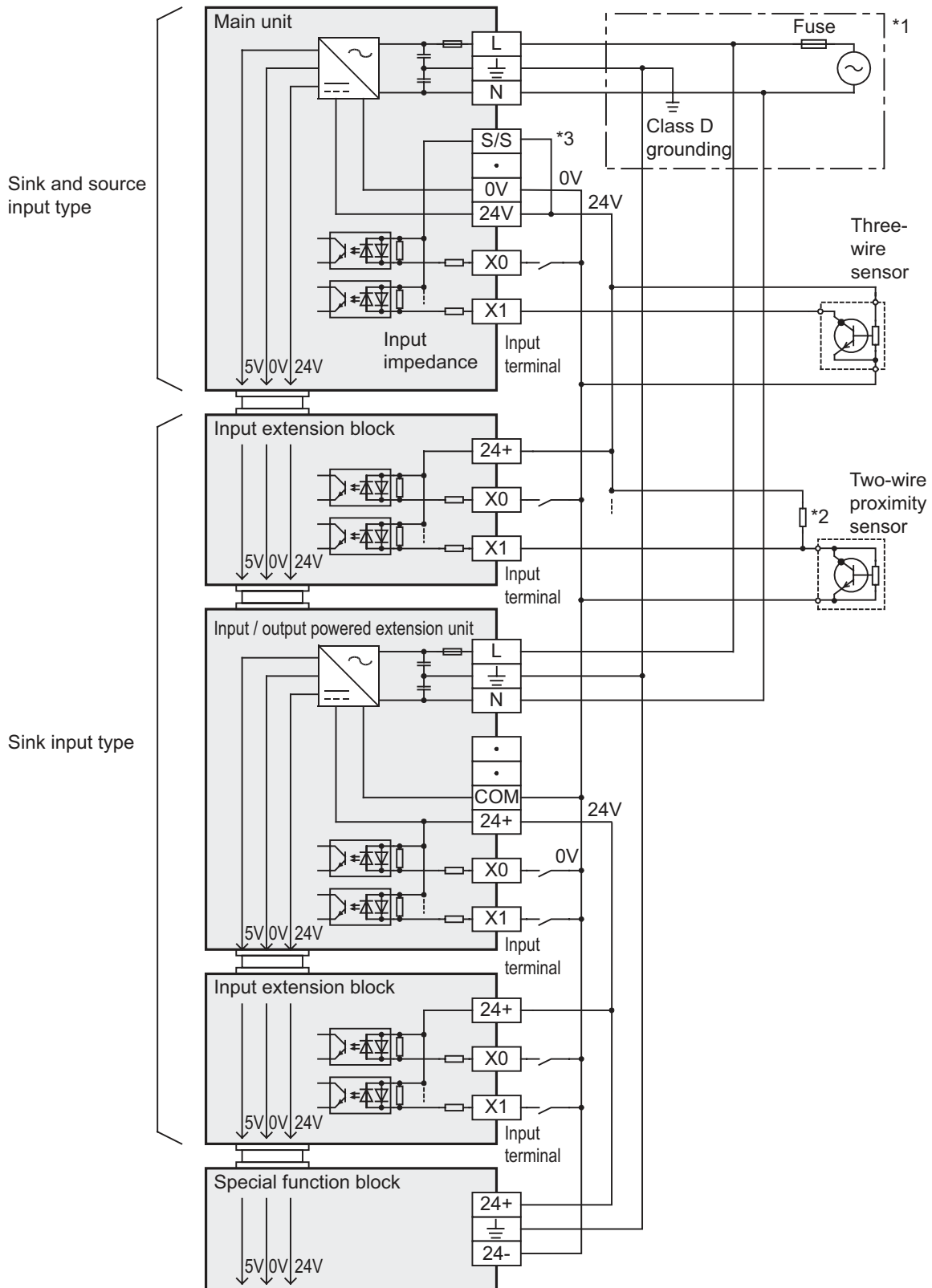

*1 Handle the power supply circuit correctly according to Chapter 9 "Preparation for Wiring and Power Supply Wiring Procedures."

*2 For an input device with a parallel resistance or a two-wire proximity switch, a bleeder resistance may be required.

*3 In case of sink input wiring, short-circuit the S/S terminal and the 24V terminal of the main unit.

10.2.5 Example of external wiring (source input) [AC Power Supply Type]

Sink and source input type

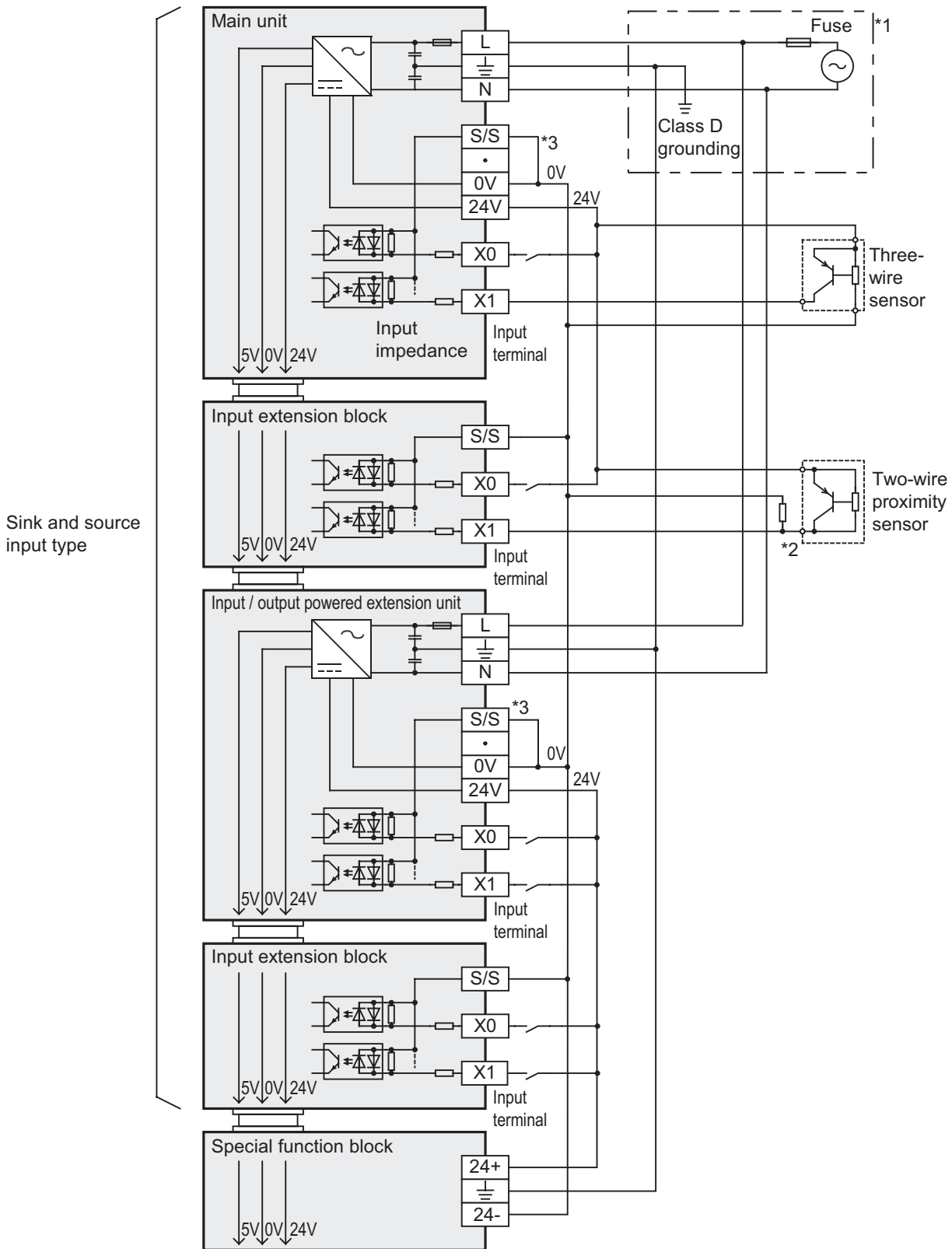

*1 Handle the power supply circuit correctly according to Chapter 9 "Preparation for Wiring and Power Supply Wiring Procedures."

*2 For an input device with a parallel resistance or a two-wire proximity switch, a bleeder resistance may be required.

*3 In case of source input wiring, short-circuit the terminals of the extension units as well as the S/S terminal and the 0V terminal of the main unit.

1	Introduction
2	Features and Part Names
3	Product Introduction
4	Specifications
5	Version and Peripheral Devices
6	System Configuration
7	Input/Output Nos., Unit Nos.
8	Installation
9	Preparation and Power Supply Wiring
10	Input Wiring

10.2.6 Examples of external wiring (sink input) [DC power supply type]

Sink and source input type

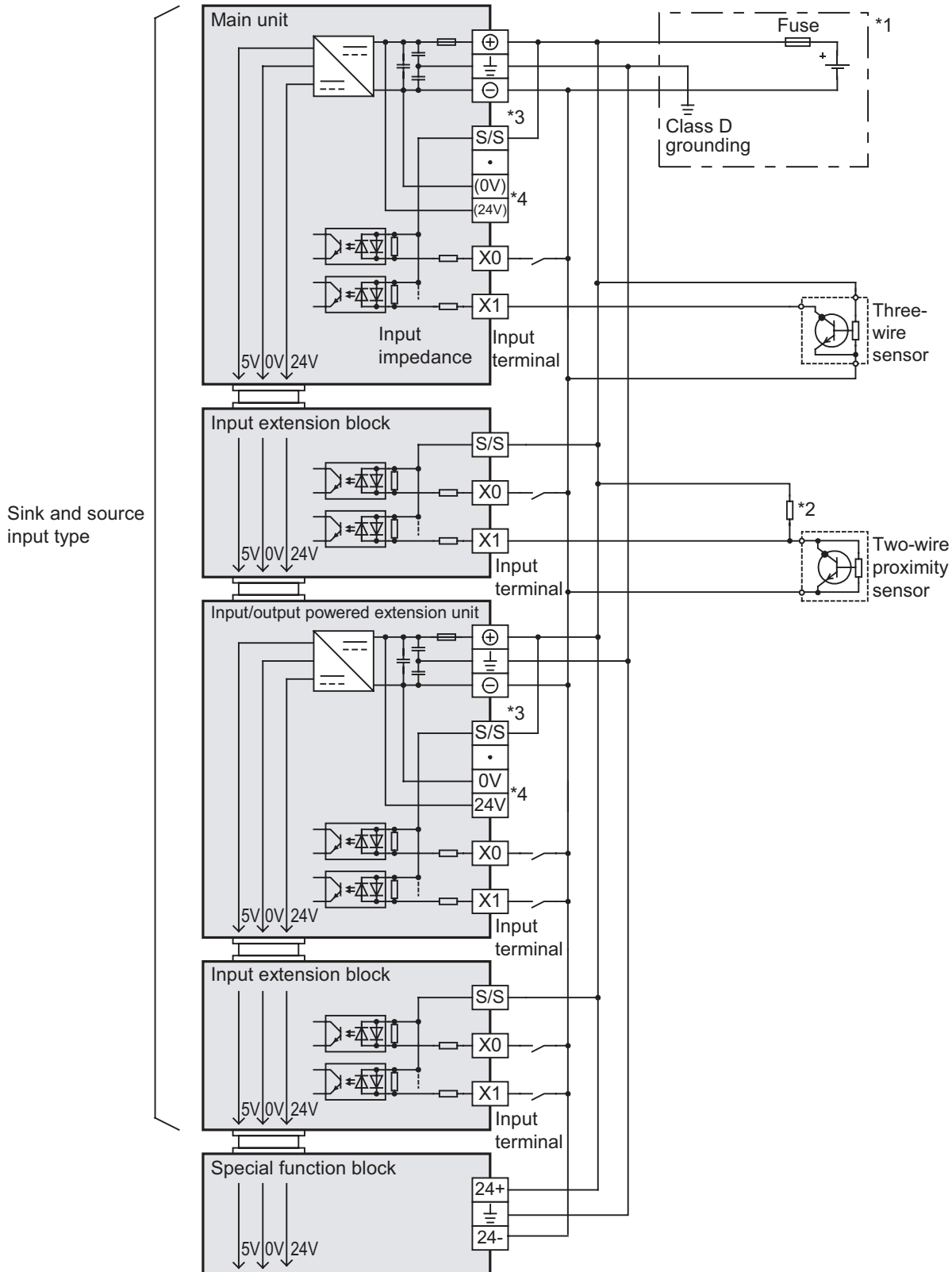

- *1 Handle the power supply circuit correctly according to Chapter 9 "Preparation for Wiring and Power Supply Wiring Procedures."
- *2 For an input device with a parallel resistance or a two-wire proximity switch, a bleeder resistance may be required.
- *3 In case of sink input wiring, short-circuit the terminals of the extension units as well as the S/S terminal and the ⊕ terminal of the main unit.
- *4 Do not connect with (0V) and (24V) terminals.

Use of input/output extension units/blocks of sink input type

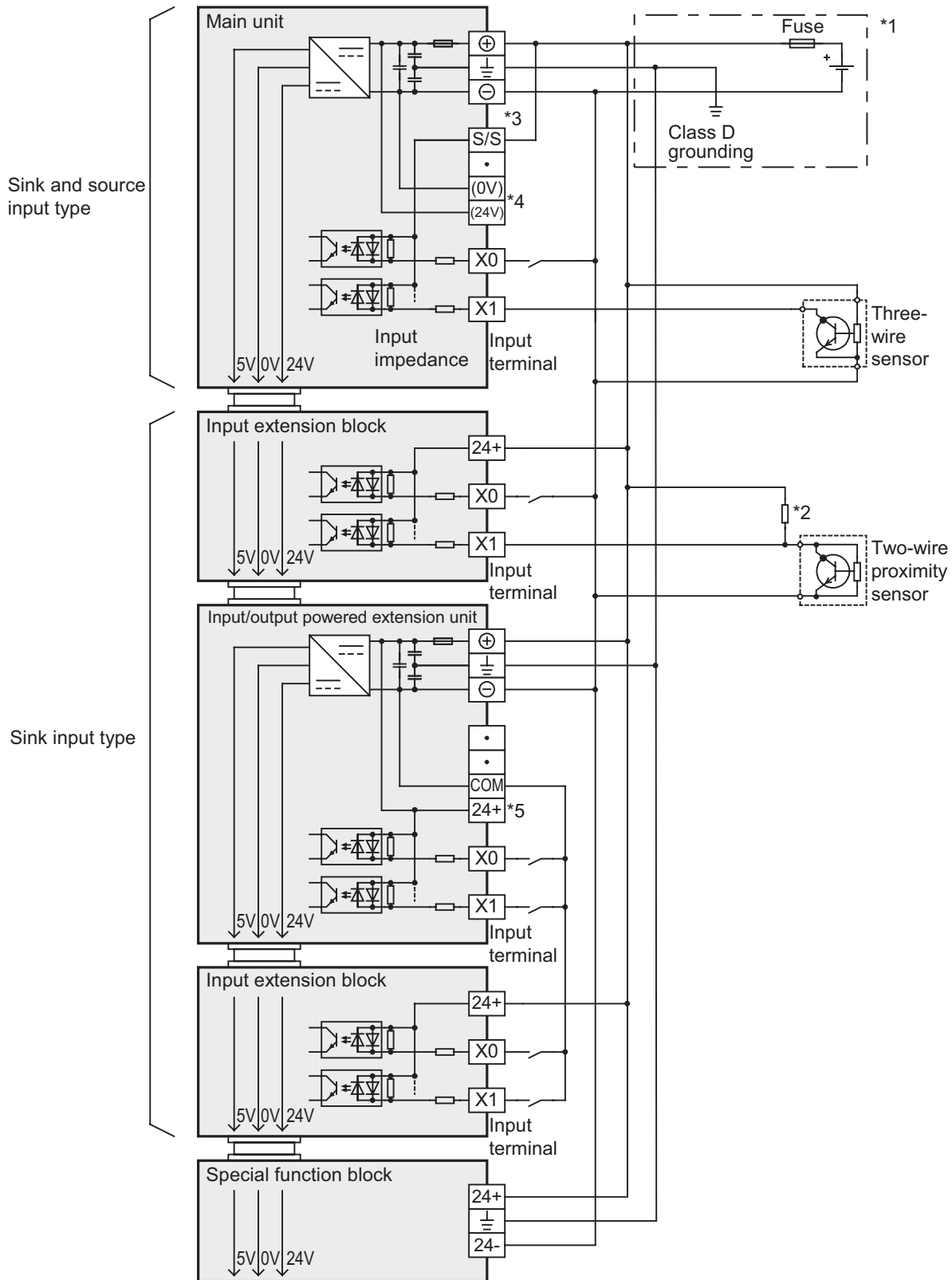

*1 Handle the power supply circuit correctly according to Chapter 9 "Preparation for Wiring and Power Supply Wiring Procedures."

*2 For an input device with a parallel resistance or a two-wire proximity switch, a bleeder resistance may be required.

*3 In case of sink input wiring, short-circuit the S/S terminal and the ⊕ terminal of the main unit.

*4 Do not connect with (0V) and (24V) terminals.

*5 Do not connect 24+ terminal.

1	Introduction
2	Features and Part Names
3	Product Introduction
4	Specifications
5	Version and Peripheral Devices
6	System Configuration
7	Input/Output Nos., Unit Nos.
8	Installation
9	Preparation and Power Supply Wiring
10	Input Wiring

10.2.7 Example of external wiring (source input) [DC Power Supply Type]

Sink and source input type

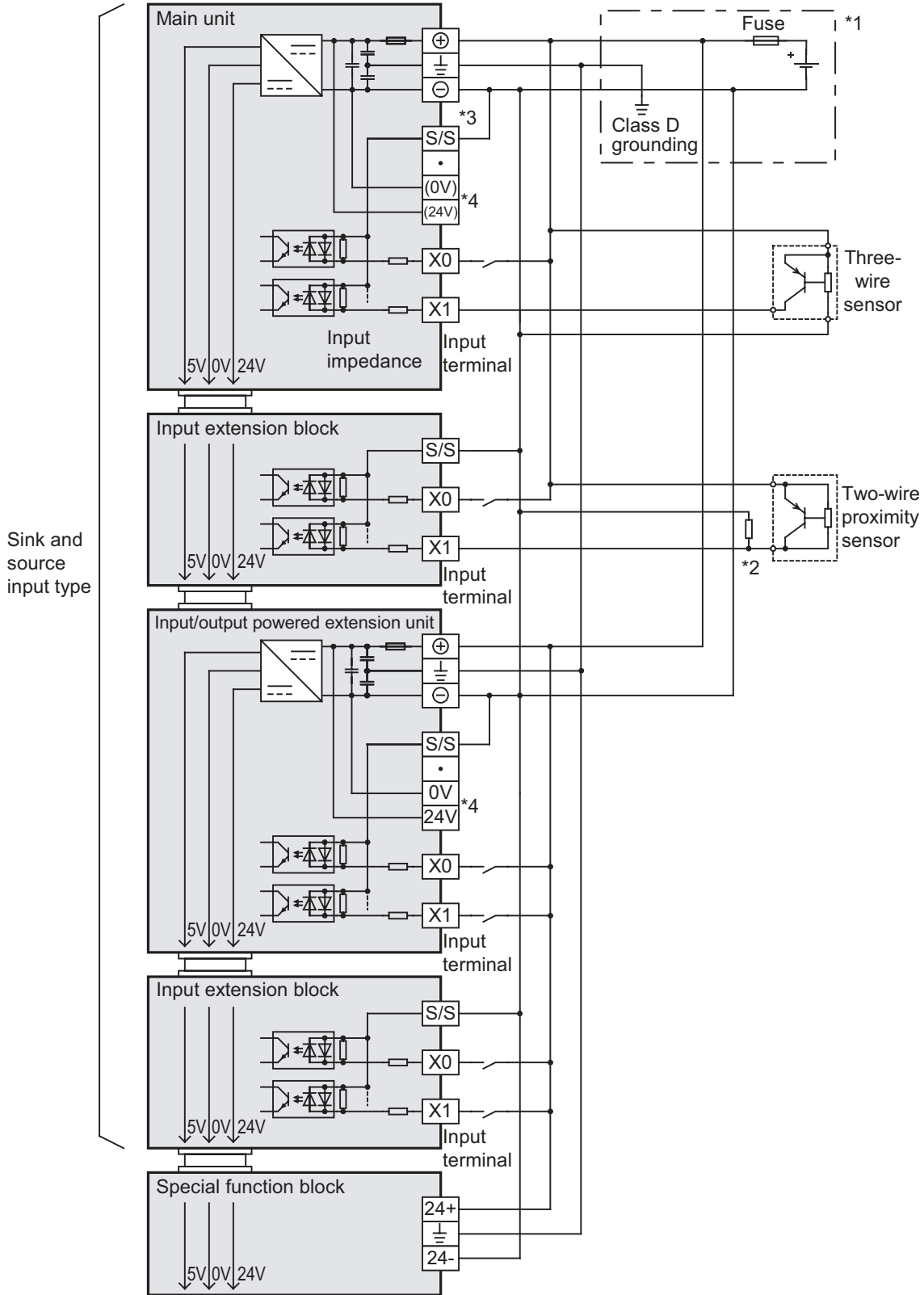

*1 Handle the power supply circuit correctly according to Chapter 9 "Preparation for Wiring and Power Supply Wiring Procedures."
 *2 For an input device with a parallel resistance or a two-wire proximity switch, a bleeder resistance may be required.
 *3 In case of source input wiring, short-circuit the terminals of the extension units as well as the S/S terminal and the ⊖ terminal of the main unit.
 *4 Do not connect with (0V) and (24V) terminals.

10.3 100V AC Input Type

The input specifications for the main unit, cautions on wiring the unit and examples of wiring are given below.

10.3.1 Input specifications (main unit)

Item	Specifications	
	FX3U-32MR/UA1	FX3U-64MR/UA1
Input points	16 points	32 points
Connection type	Removable terminal block (M3 screw)	
Input form	AC input	
Input signal voltage	100 to 120V AC +10%, -15% 50/60Hz	
Input impedance	Approx. 21 kΩ/50Hz Approx. 18 kΩ/60Hz	
Input signal current	4.7 mA/100V AC 50Hz (70% or less when turned on simultaneously) 6.2 mA/110V AC 60Hz (70% or less when turned on simultaneously)	
ON input sensitivity current	3.8 mA or more	
OFF input sensitivity current	1.7 mA or less	
Input response time	Approx. 25 to 30 ms (A high-speed receiving is improper)	
Input signal form	Contact input	
Input circuit insulation	Photocoupler insulation	
Indication of input operation	LED on panel lights when photocoupler is driven	
Input circuit diagram *1 Input impedance		

1

Introduction

2

Features and
Part Names

3

Product
Introduction

4

Specifications

5

Version and
Peripheral
Devices

6

System
Configuration

7

Input/Output
Nos., Unit Nos.

8

Installation

9

Preparation and
Power Supply
Wiring

10

Input Wiring

10.3.2 Handling of 100V AC Input

1. Input terminal

When voltage of 100 to 120V AC is applied between the input terminal and COM terminal, the input terminal is turned on. The input display LED is lit.
 Do not connect the COM terminal of an AC input type main unit and input/output powered extension unit/block with the COM terminal of a DC system.

2. Input circuit

The primary input circuit and the secondary input circuit are insulated with a photocoupler.
 There is a delay of approx. 25 to 30ms in response to input switching from ON to OFF and from OFF to ON.

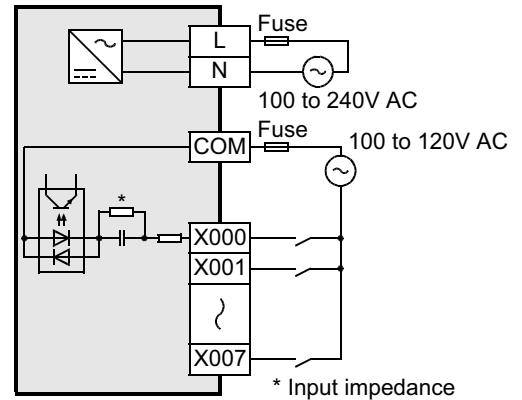

3. Input sensitivity

The input current and input sensitivity of these PLCs are shown in the following table.

Input		Specifications	
Input voltage		100 to 120V AC +10%, -15% 50/60Hz	
Input current		6.2 mA/110V 60Hz 4.7 mA/100V 50Hz	Percentage of simultaneous power-on: 70% or less
Input sensitivity	ON	3.8 mA or more	
	OFF	1.7 mA or less	

4. Cautions on use

The response time of the AC input type is slower than that of the DC input type.
 The applications shown below are not supported.

Unsupported Applications	
High-speed processing	High-speed counter, input interruption, pulse catch, speed detection (SPD) instruction
Time division input	Input matrix (MTR) instruction, hexadecimal input (HKY) instruction, digital switch (DSW) instruction, arrow switch (ARWS) instruction
Other	Refresh and filter adjust (REFF) instruction, ten key input (TKY) instruction, absolute current value read (ABS) instruction

10.3.3 Example of external wiring

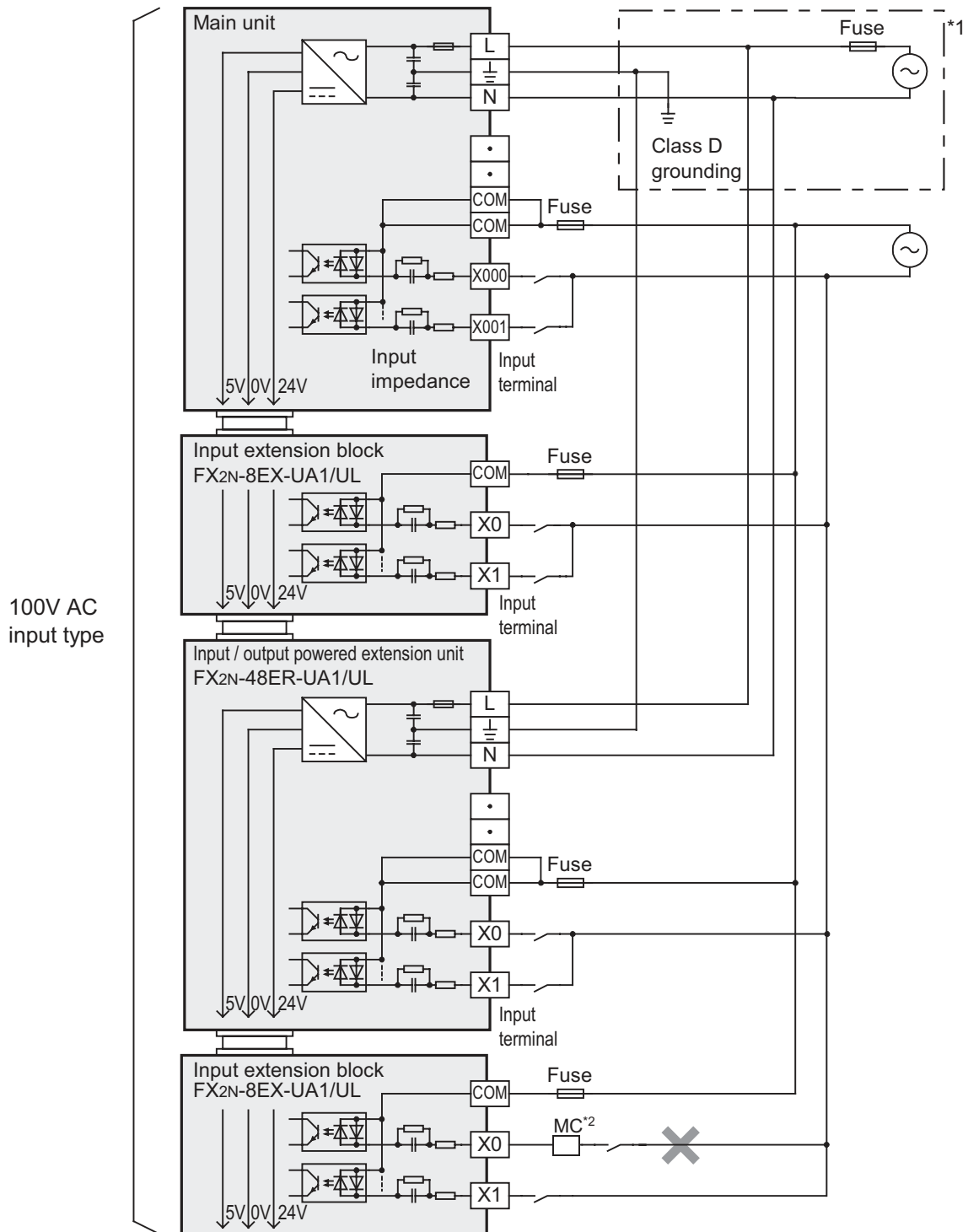

*1 Handle the power supply circuit correctly according to Chapter 9 "Preparation for Wiring and Power Supply Wiring Procedures."

*2 Do not take input signals from loads generating surge.

1	Introduction
2	Features and Part Names
3	Product Introduction
4	Specifications
5	Version and Peripheral Devices
6	System Configuration
7	Input/Output Nos., Unit Nos.
8	Installation
9	Preparation and Power Supply Wiring
10	Input Wiring

10.4 Input Interruption (I00□ to I50□) - With Delay Function

The PLC (main unit/DC input type) is provided with an input interruption function (input delay interruption function) and has six interruption input points.

The ON or OFF duration of interruption input signals should be 5μs or more.

→ For details on programming, refer to the programming manual.

10.4.1 Allocation of pointers to input numbers (input signal ON/OFF duration)

Input No.	Interrupt pointer		Interrupt disable control	ON or OFF duration of input signal
	Interruption on leading edge	Interruption on trailing edge		
X000	I001	I000	M8050	5μs or more
X001	I101	I100	M8051	
X002	I201	I200	M8052	
X003	I301	I300	M8053	
X004	I401	I400	M8054	
X005	I501	I500	M8055	

10.4.2 Input interruption delay function

This input interruption has a function to delay execution of interruption routine in 1ms units.

With this delay function, the position of the sensor used for input interruption can be adjusted in the sequence program. It is unnecessary to adjust the actual position of the sensor.

→ For the programming, refer to the programming manual.

10.4.3 Cautions for input interruption

1. Non-overlap of input numbers

The input terminals X000 to X007 can be used for high-speed counter, input interruption, pulse catch, SPD, ZRN, DSZR and DVIT instructions and general-purpose inputs.

Take care not to overlap the input numbers.

Example:

When the input interrupt pointer "I001" is used, X000 is occupied. Therefore, it is impossible to use C235, C241, C244, C246, C247, C249, C252 and C254, input interruption (including delay interruption) pointer I000, pulse catch contact M8170 and SPD, ZRN, DSZR and DVIT instructions at the same time.

2. Cautions on wiring

- The wiring length should be 5m or less.
- Connect a bleeder resistance of 1.5kΩ (1 W or more) to the input terminal, so that the sum of the load current of the open collector transistor output on the other side device and the input current of the main body is 20 mA or more.
 - Source input: PNP open collector transistor
 - Sink input: NPN open collector transistor

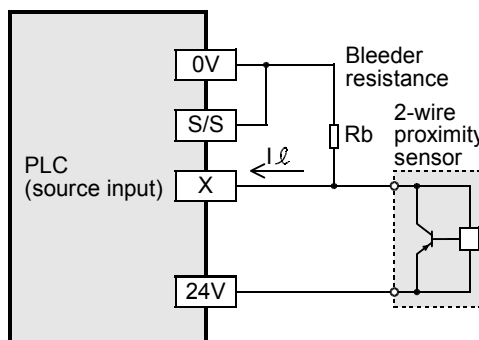
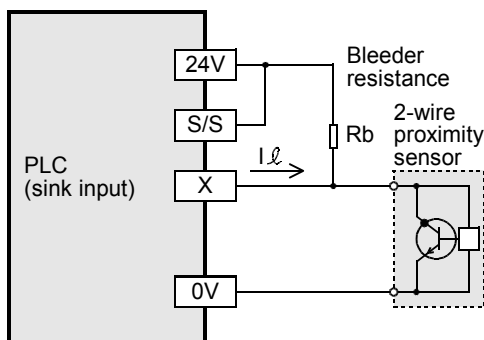

10.4.4 Examples of external wiring

Use shielded twisted-pair cables for connecting cables.
Ground the shield of each shielded cable only on the PLC side.

1. Examples of input interruption (I000 or I001) wiring using X000

When another input terminal is used, wire it according to the following diagrams.

1) When 24V DC service power supply is used

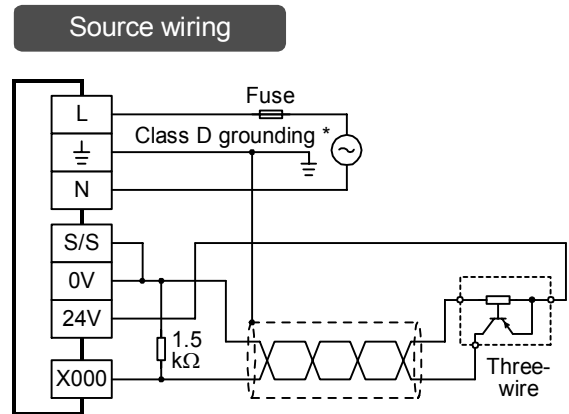
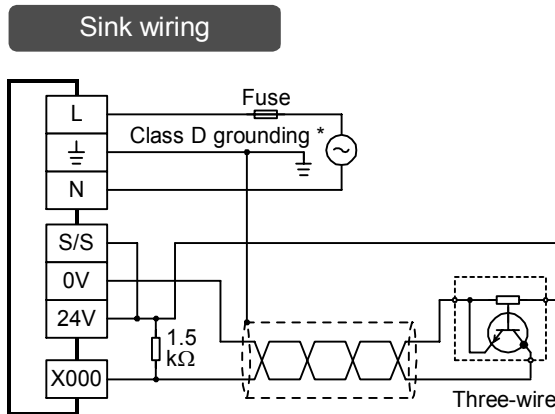

* The grounding resistance should be 100Ω or less.

2) When 24V DC external power supply is used

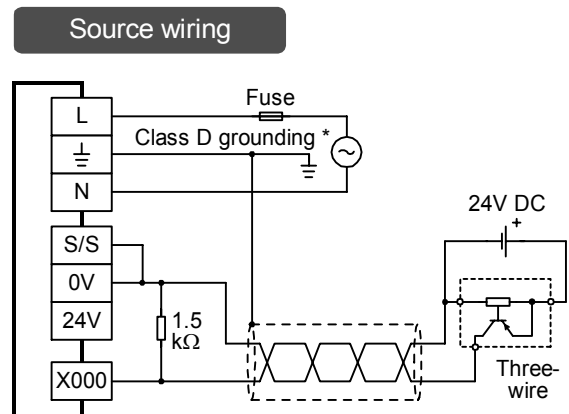
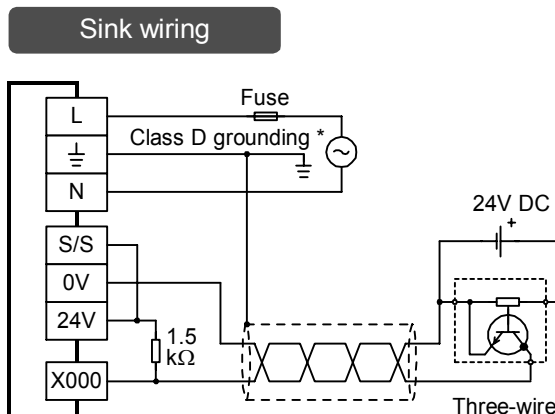

* The grounding resistance should be 100Ω or less.

1

Introduction

2

Features and
Part Names

3

Product
Introduction

4

Specifications

5

Version and
Peripheral
Devices

6

System
Configuration

7

Input/Output
Nos., Unit Nos.

8

Installation

9

Preparation and
Power Supply
Wiring

10

Input Wiring

10.5 Pulse Catch (M8170 to M8177)

The PLC (main unit/DC input type) is provided with a pulse catch function and has 8 pulse catch input points.
→ For details on programming, refer to the programming manual.

10.5.1 Allocation of special memories to input numbers (ON duration of input signals)

Input No.	Contact on sequence program	ON duration of input signal
X000	M8170	5μs or more
X001	M8171	
X002	M8172	
X003	M8173	
X004	M8174	
X005	M8175	
X006	M8176	50μs or more
X007	M8177	

10.5.2 Cautions for pulse catch

1. Non-overlap of input numbers

The input terminals X000 to X007 can be used for high-speed counter, input interruption, pulse catch, speed detection (SPD) instructions and general-purpose input.
Take care not to overlap the input numbers.

Example:

When the pulse catch input contact M8170 is used, X000 is occupied. Therefore, it is impossible to use C235, C241, C244, C246, C247, C249, C252 and C254, input interruption (including delay interruption) pointers I000 and I001 and SPD, ZRN, DSZR and DVIT instructions at the same time.

2. Cautions on wiring

- The wiring length should be 5 m (16'4") or less.
- Connect a bleeder resistance of 1.5kΩ (1 W or more) to the input terminal, so that the sum of the load current of the open collector transistor output on the other side device and the input current of the main body is 20 mA or more.

10.5.3 Examples of external wiring

Use shielded twisted-pair cables for connecting cables.
Ground the shield of each shielded cable only on the PLC side.

1. Examples of pulse catch (M8170) wiring using X000

When another input terminal is used, wire it according to the following diagrams.

1) When 24V DC service power supply is used

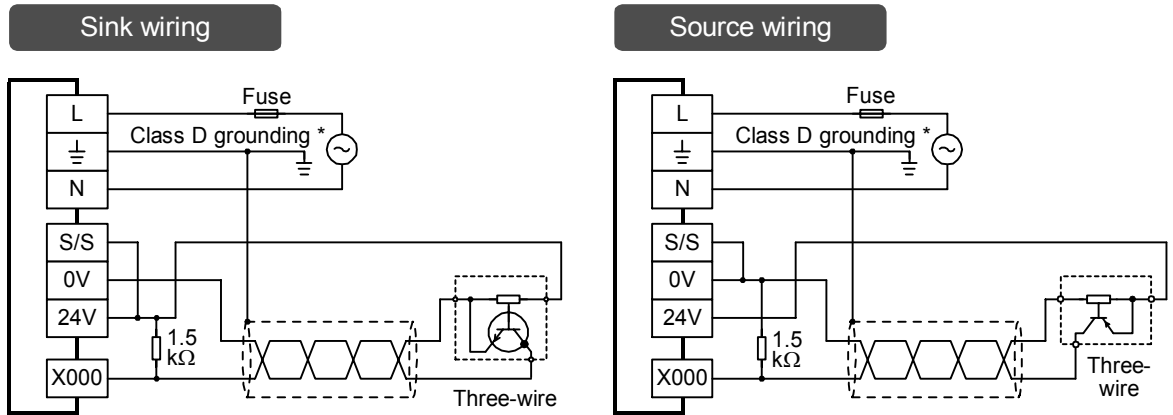

* The grounding resistance should be 100Ω or less.

2) When 24V DC external power supply is used

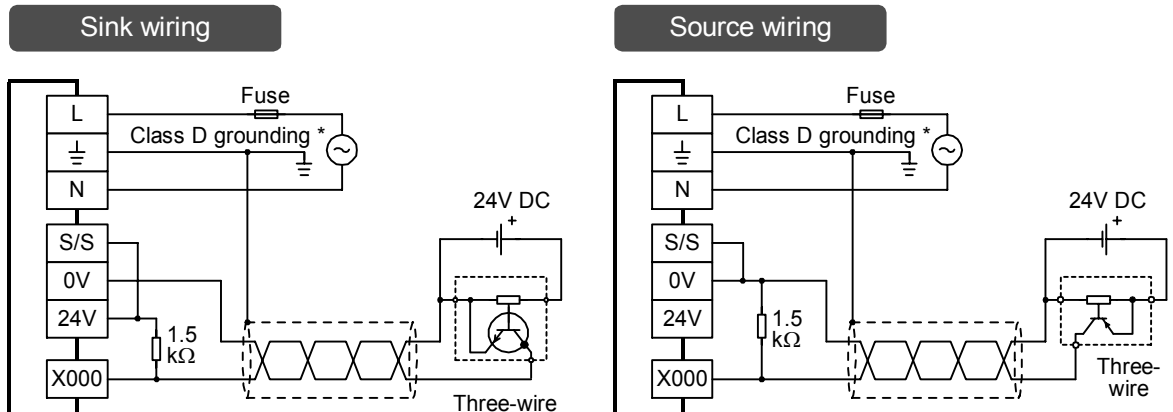

* The grounding resistance should be 100Ω or less.

1	Introduction
2	Features and Part Names
3	Product Introduction
4	Specifications
5	Version and Peripheral Devices
6	System Configuration
7	Input/Output Nos., Unit Nos.
8	Installation
9	Preparation and Power Supply Wiring
10	Input Wiring

11. Use of High-speed Counters (C235 to C255)

High-speed counters corresponds only to the DC input type main unit.

11.1 Outline

The high-speed counters can count the signals to the general-purpose input terminals to the main unit or to the high-speed input special adapters (options). These two types of counters differ in the maximum response frequency and type of input signals to be counted.

→ For details, refer to Section 11.2.

- General-purpose input terminals of main unit
Signals from an open collector transistor output can be input to the counters. The counters can count signals of up to 100kHz (1-phase).
- High-speed input special adapters
Signals from a differential line driver output can be input to the counters. The counters can count signals of up to 200kHz (1-phase).

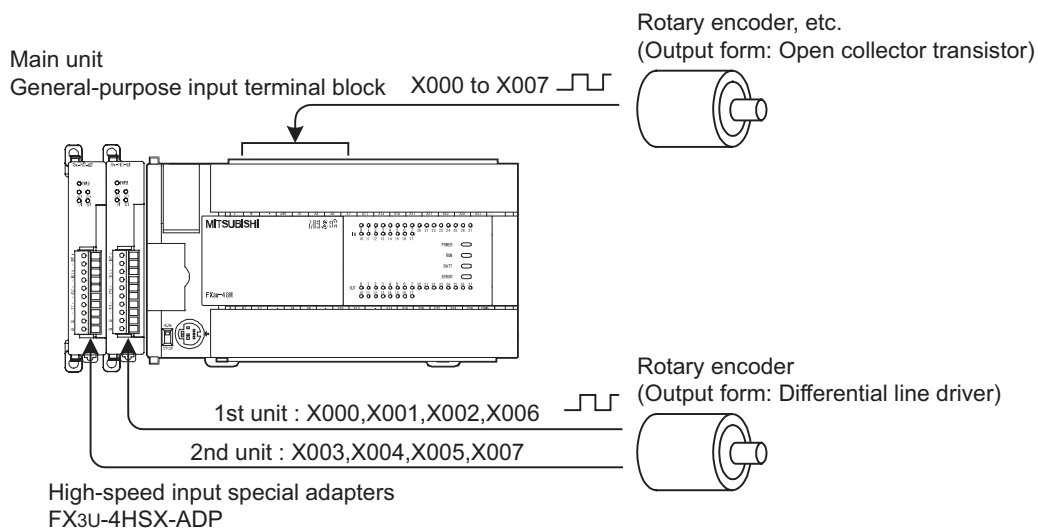

Cautions for high-speed input special adapters

Do not use the same input number for both the high-speed input special adapter terminal and the main unit terminal.

- When wiring the input numbers assigned to a high-speed input special adapter, do not wire the same input number in main unit.
- When not wiring the input numbers assigned to a high-speed input special adapter, the main unit's input terminals can be used as general inputs.

11.2 Input Specifications

For input to the high-speed counters, the input terminals X000 to X007 of the main unit or high-speed input special adapter are used.

→ For the input specifications for X000 to X007 of the main unit, refer to Section 10.2.

11.2.1 High-speed input special adapter (FX3U-4HSX-ADP)

1. Performance specifications

Item	Specification		
Number of input points	4 points (These points are not included in the total number of PLC input/output points.)		
Input form	Differential line receiver (equivalent to AM26C32)		
Max. input frequency	1-phase 1-input	200kHz	High-speed counter operating with hardware counter*1
	1-phase 2-input		
	2-phase 2-input	100kHz	
Min. pulse width	1 μs or more		
Insulation	The external wiring of the input block and the PLC are insulated with a photocoupler or a transformer.		
Wiring length	Up to 10m		

*1. The maximum input frequency to the software counters*2 is the same as that of signals to be captured to the input terminals of the main unit.
→ For details on the response frequency, refer to Subsection 11.9.2.

*2. The software counters include hardware counters that operate as software counters.
→ For the conditions under which the hardware counters operate as software counters, refer to Subsection 11.8.1.

2. Internal circuit of input interface

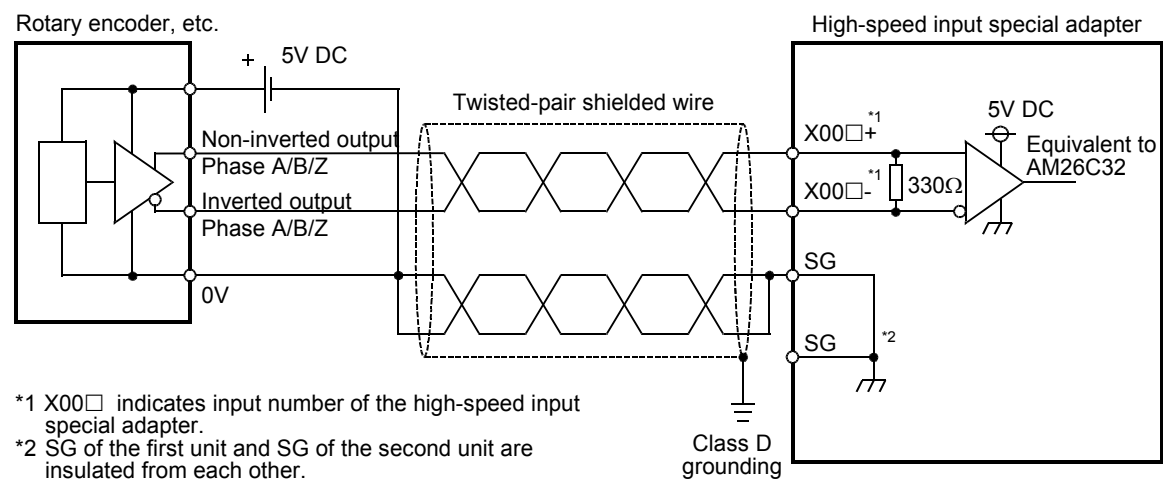

11.2.2 Cautions on connecting mating device

Encoders with the output forms in the following table can be connected to the input terminals. (The encoders may not function correctly depending on electrical compatibility. Check the specifications in advance.) Voltage output type encoders and absolute encoders cannot be connected to the high-speed counter input terminals.

Terminals for connecting	Output form that can be directly connected
Input terminals of main unit	Open collector transistor output form (applicable to 24V DC)
Input terminals of FX3U-4HSX-ADP	Differential line driver output form Set the input voltage of FX3U-4HSX-ADP to 5V DC or less.

11.3 Types of Counting and Operations

The main unit has built-in 32-bit high-speed bi-directional counters (1-phase 1-count input, 1-phase 2-count input and 2-phase 2-count input). The high-speed counters are classified into hardware counters and software counters according to the counting method.

For some high-speed counters, external reset input terminals or external start input terminals (start of counting) can be selected.

11.3.1 Classification according to counting method

Classification	Details
Hardware counters	Counting by hardware They are switched to software counters under some working conditions.
Software counters	Counting through interrupt handling by CPU Each counter must be used within limitations on maximum response frequency and overall frequency.

11.3.2 Types and input signal forms

The types and input signals (waveforms) of high-speed counters (1-phase 1-count input, 1-phase 2-count input and 2-phase 2-count input) are shown below.

Type of counter	Input signal form	Counting direction
1-phase 1-count input	UP/DOWN	Down-counting or up-counting is specified by turning on or off M8235 to M8245. ON: Down-counting OFF: Up-counting
1-phase 2-count input	UP DOWN	Up-counting or down-counting The counting direction can be checked with M8246 to M8250. ON: Down-counting OFF: Up-counting
2-phase 2-count input	1 edge count Phase A Phase B	Automatic up-counting or down-counting according to change in input status of phase A/B The counting direction can be checked with M8251 to M8255. ON: Down-counting OFF: Up-counting
	4 edge count Phase A Phase B	

11.3.3 High-speed counter device notations

The input terminal assignments for FX3U PLC high-speed counters can be switched when used in combination with a special auxiliary relay.

This section classifies these high-speed counter devices under the following notations. Note that an "(OP)" input cannot be programmed.

Standard Device Numbers	Switched Device Numbers	Standard Device Numbers	Switched Device Numbers
C244	C244(OP)	C248	C248(OP)
C245	C245(OP)	C253	C253(OP)

11.4 List of Device Numbers and Functions

→ For details on the counter number (OP), refer to Subsection 11.3.3.

Counter type	Device No. (counter)	Classification	1 edge count/ 4 edge count	Data length	External reset input terminal	External start input terminal
1-phase 1-count input	C235* ² C236* ² C237* ² C238* ² C239* ² C240* ²	Hardware counter* ¹	–	32-bit bi-directional counter	None	None
	C244(OP)* ³ C245(OP)* ³		–			
	C241 C242 C243	Software counter	–		Provided* ⁵	None
	C244* ³ C245* ³		–		Provided* ⁵	Provided
1-phase 2-count input	C246* ² C248(OP)* ^{2*3}	Hardware counter* ¹	–	32-bit bi-directional counter	None	None
	C247 C248* ³	Software counter	–		Provided* ⁵	None
	C249 C250		–		Provided* ⁵	Provided
2-phase 2-count input	C251* ² C253* ²	Hardware counter* ¹	1 edge count* ⁴	32-bit bi-directional counter	None	None
			4 edge count* ⁴			
	1 edge count* ⁴		Provided* ⁵			
	4 edge count* ⁴					
	C252 C253(OP)* ⁶ C254 C255	Software counter	1 edge count* ⁴		Provided* ⁵	None
			4 edge count* ⁴			
			1 edge count* ⁴		None	
			4 edge count* ⁴			
1 edge count* ⁴	Provided* ⁵		Provided			
4 edge count* ⁴						

- *1. These counters are handled as software counters depending on working conditions. When they are handled as software counters, they have limitations on maximum response frequency and overall frequency.
→ For the conditions under which they are handled as software counter, refer to Section 11.8.
→ For the overall frequency, refer to Section 11.9.
- *2. When the input terminals of the main unit receive pulses with a response frequency of 50 kHz to 100 kHz, wire the terminals as stated below.
- The wiring length should be 5m (16'4") or less.
- Connect a bleeder resistance of 1.5kΩ (1W or more) to the input terminal, so that the load current of the open collector transistor output on the mating device side is 20mA or more.
→ For the wiring, refer to Section 11.10.
- *3. C244, C245 and C248 are usually used as software counters. When they are used in combination with special auxiliary relays (M8388 and M8390 to M8392), they can be used as hardware counters C244(OP), C245(OP) and C248(OP).
→ For the procedures on switching the counter function, refer to Subsection 11.11.3.
- *4. The 2-phase 2-input counters are 1 edge count counters. When they are used in combination with special auxiliary relays (M8388, M8198 and M8199), they can be used as 4 edge count counters.
→ For the procedures on using them as 4 edge count counters, refer to Subsection 11.11.4.

11	High-Speed Counters
12	Output Wiring
13	Wiring for Various Uses
14	Test Run, Maintenance, Troubleshooting
15	Input/Output Powered Extension Units
16	Input/Output Extension Blocks
17	Extension Power Supply Unit
18	Other Extension Units and Options
19	Display Module
20	Terminal Block

- *5. The external reset input terminals are reset when they are turned on. When they are used in combination with special auxiliary relays (M8388 and M8389), they can be reset when turned off.
→ **For the procedures on changing the external reset input logic, refer to Subsection 11.11.3.**
- *6. C253 is usually used as a hardware counter. When it is used in combination with the special auxiliary relay (M8388 and M8392), it can be used as a counter C253(OP) without reset input.
In this case, C253(OP) is handled as a software counter.

11.5 Allocation of Device Numbers to Input Numbers

The high-speed counter numbers are allocated to the input terminals X000 to X007 as shown in the following table.

The input terminals not allocated for high-speed counters can be used as general input terminals.

11.5.1 Allocation table

The allocation of the first unit of FX3U-4HSX-ADP is shown in the heavy-line frames.

H/W: Hardware counter S/W: Software counter U: Up-count input D: Down-count input
A: A-phase input B: B-phase input R: External reset input S: External start input

Terminals to be connected		Input allocation							
		X000	X001	X002	X003	X004	X005	X006	X007
• Input terminals of main unit		✓	✓	✓	✓	✓	✓	✓	✓
• FX3U-4HSX-ADP High-speed input special adapters	1st unit	✓	✓	✓	–	–	–	✓	–
	2nd unit	–	–	–	✓	✓	✓	–	✓

Type of counter	Counter No.	Classification	Input allocation							
			X000	X001	X002	X003	X004	X005	X006	X007
1-phase 1-count input	C235* ¹	H/W* ²	U/D							
	C236* ¹	H/W* ²		U/D						
	C237* ¹	H/W* ²			U/D					
	C238* ¹	H/W* ²				U/D				
	C239* ¹	H/W* ²					U/D			
	C240* ¹	H/W* ²						U/D		
	C241	S/W	U/D	R						
	C242	S/W			U/D	R				
	C243	S/W					U/D	R		
	C244	S/W	U/D	R						S
	C244(OP)* ³	H/W* ²							U/D	
C245	S/W			U/D	R				S	
C245(OP)* ³	H/W* ²								U/D	
1-phase 2-count input	C246* ¹	H/W* ²	U	D						
	C247	S/W	U	D	R					
	C248	S/W				U	D	R		
	C248(OP)* ¹⁺³	H/W* ²				U	D			
	C249	S/W	U	D	R					S
C250	S/W				U	D	R		S	
2-phase 2-count input* ⁴	C251* ¹	H/W* ²	A	B						
	C252	S/W	A	B	R					
	C253* ¹	H/W* ²				A	B	R		
	C253(OP)* ³	S/W				A	B			
	C254	S/W	A	B	R					S
C255	S/W				A	B	R		S	

- *1. When the input terminals of the main unit receive pulses with a response frequency of 50 kHz to 100 kHz, wire the terminals as stated below.
- The wiring length should be 5m (16'4") or less.
 - Connect a bleeder resistance of 1.5kΩ (1 W or more) to the input terminal, so that the load current of the open collector transistor output on the mating device side to 20mA or more.
- For the wiring, refer to Section 11.10.

- *2. When the comparison set/reset instructions (DHSCS, DHSCR, DHSZ and DHSCT) for high-speed counters are used, the hardware (H/W) counters are switched to software (S/W) counters. When the input signal logic is inverted by the reset input signal logic switching function (M8388 and M8389), C253 is switched from a hardware counter to a software counter.
→ **For the conditions under which it is handled as a software counter, refer to Section 11.8.**
- *3. The input terminals to be used and the functions are switched by driving the special auxiliary relays in the program.
→ **For the procedures on switching to hardware counters, refer to Subsection 11.11.3.**
- *4. The 2-phase 2-count input counters are 1 edge count counters. The use of special auxiliary relays changes them to 4 edge count counters.
→ **For the procedures on operating them as 4 edge count counters, refer to Subsection 11.11.4.**

11.5.2 Inhibition of redundant use of input numbers

- The input terminals X000 to X007 can be used for high-speed counters, input interruption, pulse catch, SPD, ZRN, DSZR and DVIT instructions and general-purpose inputs. Take care not to overlap the input numbers.
For example, when C251 is used, X000 and X001 are occupied. Therefore, it is impossible to use C235, C236, C241, C244, C246, C247, C249, C252 and C254, input interruption pointers I000 and I101, pulse catch contacts M8170 and M8171 and SPD, ZRN, DSZR and DVIT instructions at the same time.
- The same input numbers are allocated to the input terminals on FX3U-4HSX-ADP and the input terminals of the main unit of FX3U PLC. Use one of the terminals with the same number. If both input terminals are being used, intended operation cannot be realized because the input terminals on FX3U-4HSX-ADP and the main unit operate in the OR relation.

11.6 Handling of High-speed Counters

11.6.1 1-phase 1-count input

Examples of program

1) For C235

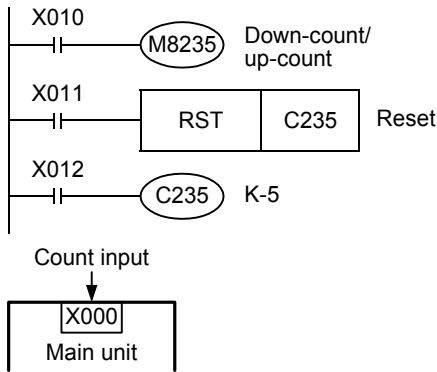

- C235 counts the number of times the input terminal X000 switches from OFF to ON while X012 is on.
- While X011 is on, the counter resets when RST instruction is executed.
- The counters C235 to C245 switch to the down-count or up-count mode by turning on or off M8235 to M8245.

2) For C244

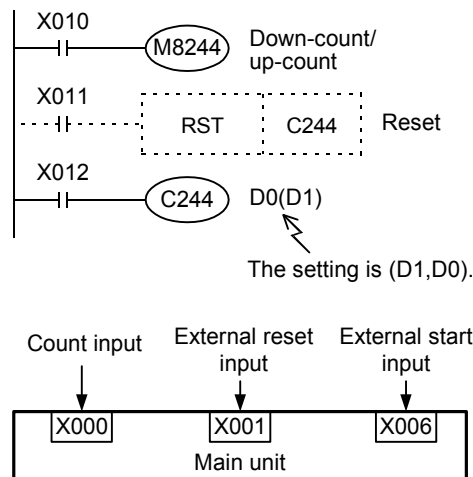

- C244 starts counting immediately when the input terminal X006 turns on while X012 is on. The count input terminal is X000. The setting for this example is the data of the indirectly designated data register (D1,D0).
- C244 can be reset by X011 on the sequence. For C244, X001 is allocated as the external reset input. The counter resets immediately when X001 turns on.
- The counters C235 to C245 switch to the down-count or up-count mode by turning on or off M8235 to M8245.

Example of operation

The above counter C235 operates as shown below.

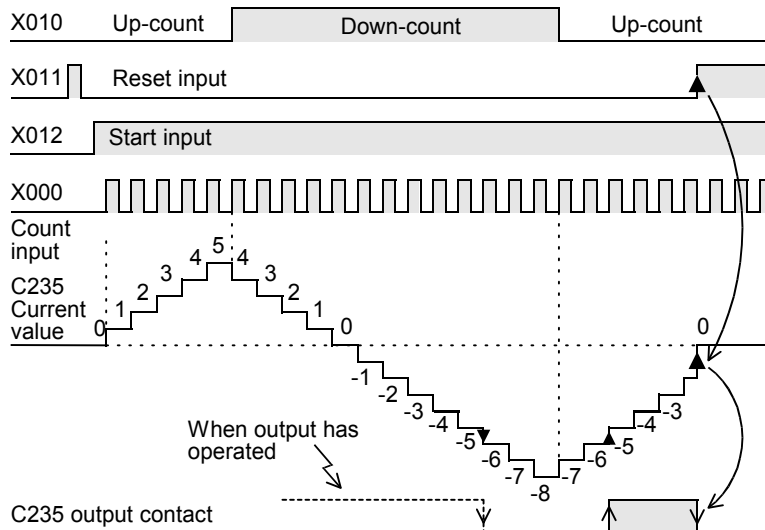

C235 is set to the up-count or down-count mode through interruption by the count input X000.

11	High-Speed Counters
12	Output Wiring
13	Wiring for Various Uses
14	Test Run, Maintenance, Troubleshooting
15	Input/Output Powered Extension Units
16	Input/Output Extension Blocks
17	Extension Power Supply Unit
18	Other Extension Units and Options
19	Display Module
20	Terminal Block

- When the current value increases from -6 to -5, the output contact is set, and when the value decreases from -5 to -6, it is reset.
- The current value increases and decreases regardless of the operation of the output contact. However, when the counter's value increments from 2,147,483,647, it changes to -2,147,483,648. In the same manner, when it decrements from -2,147,483,648, it changes to 2,147,483,647. (This type of counter is called a ring counter.)
- When RST instruction is executed after the reset input X011 turns on, the current counter's value resets to 0, and the output contact is restored.
- The current values, output contact operations and reset status of the high-speed counters for retention upon power failure are kept even if power is turned off.

11.6.2 1-phase 2-count input

These counters are 32-bit up-count/down-count binary counters. The operations of the output contact according to the current value are the same as those of the above-mentioned 1-phase 1-count input high-speed counters.

Examples of program

1) For C246

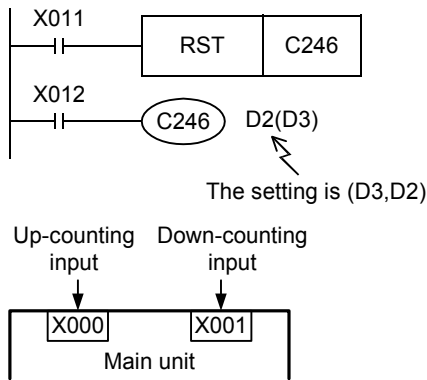

- While X012 is on, C246 increments the value when the input terminal X000 switches from OFF to ON and decrements the value when the input terminal X001 switches from OFF to ON.
- The down-count/up-count operations of C246 to C250 can be monitored through the ON/OFF operations of M8246 to M8250.
ON: Down-counting
OFF: Up-counting

2) For C249

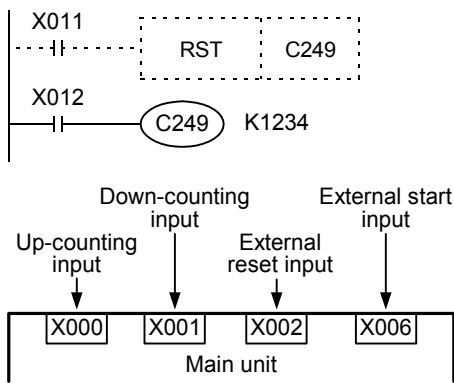

- While X012 is on, C249 starts counting immediately when the input terminal X006 turns on. The up-counting input terminal is X000, and the down-counting input terminal is X001.
- C249 can be reset on the sequence by X011. For C249, X002 is allocated as reset input. When X002 turns on, C249 is immediately reset.
- The down-count/up-count operations of C246 to C250 can be monitored through the ON/OFF operations of M8246 to M8250.
ON: Down-counting
OFF: Up-counting

11.6.3 2-phase 2-count input

These counters are 32-bit up-count/down-count binary counters. The operations of the output contact according to the current value are the same as those of the above-mentioned 1-phase 1-count input high-speed counters.

Examples of program

1) For C251

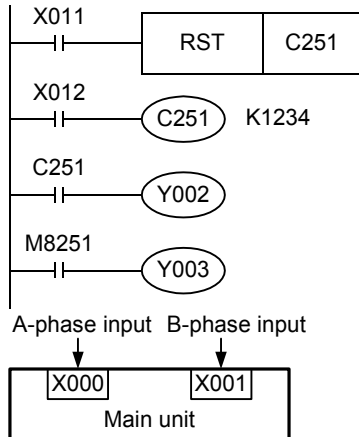

- While X012 is on, C251 counts the operation of the input terminals X000 (A-phase) and X001 (B-phase) through interruption. While X011 is turned on, the counter is reset when RST instruction is executed.
- When the current value exceeds the setting, Y002 turns on, and when the current value becomes lower than the setting, Y002 turns off.
- Y003 turns on (down-count) or off (up-count) according to the counting direction.

2) For C254

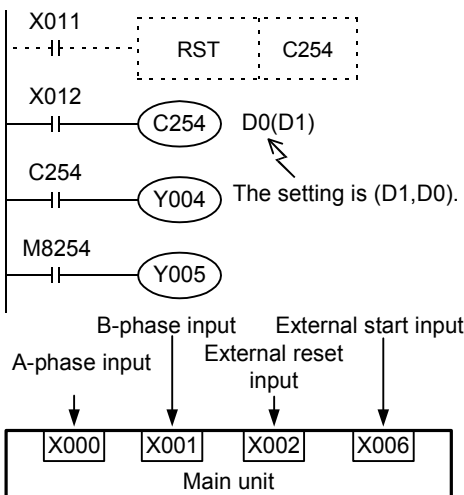

- C254 starts counting immediately when the input terminal X006 is turned on while X012 is on. The count input terminals are X000 (A-phase) and X001 (B-phase).
- C254 is reset by X011 on the sequence, and it is reset immediately when X002 is turned on.
- When the current value exceeds the setting (D1,D0), Y004 operates, and when the current value becomes lower than the setting, Y004 turns off.
- Y005 turns on (down-count) or off (up-count) according to the counting direction.

- A 2-phase encoder generates A-phase output and B-phase output between which there is a 90° phase difference. The high-speed counter automatically counts up or down according to the output as shown below.

- Operation by 1 edge count

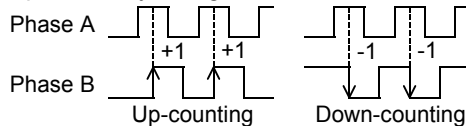

- Operation by 4 edge count

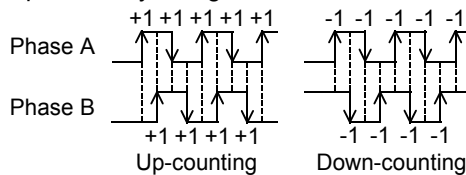

- The down-count/up-count operations of C251 to C255 can be monitored through the ON/OFF operations of M8251 to M8255.
ON: Down-counting
OFF: Up-counting

11	High-Speed Counters
12	Output Wiring
13	Wiring for Various Uses
14	Test Run, Maintenance, Troubleshooting
15	Input/Output Powered Extension Units
16	Input/Output Extension Blocks
17	Extension Power Supply Unit
18	Other Extension Units and Options
19	Display Module
20	Terminal Block

11.7 Timing of Updating of Current Value and Comparison of Current Value

11.7.1 Timing of updating of current value

When a pulse is input to a high-speed counter input terminal, the counter increments or decrements. The current value of the device is updated at the timing shown in the following table.

Therefore, when the hardware counter directly handles the current value of the high-speed counter for MOV instruction or CMP instruction or an applied instruction (such as a contact comparison instruction), it uses the current value updated at the timing shown in the following table. As a result, the counter operation is affected by the scan time.

Classification	Timing of updating of current value
Hardware counter	OUT instruction of counter HCMOV instruction
Software counter	When count is input

11.7.2 Comparison of current value

To compare and output the current value of a high-speed counter, the following two methods are available.

1. Use of comparison instruction (CMP), band comparison instruction (ZCP) or contact comparison instruction

When the comparison results are necessary for counting operation, the value can be compared with time*¹ in the main program by using HCMOV instruction just before a comparison command (CMP command/ZCP command) or a contact comparison instruction.

- *1. To compare the value with the high-speed counter's changing value and to change the output contact (Y), use Comparison instruction for high-speed counters (HSCS/HSCR/HSZ/HSCT instruction).

2. Use of Comparison instruction for high-speed counters (HSCS/HSCR/HSZ/HSCT instruction)

Comparison instructions for high-speed counters (HSCS, HSCR, HSZ and HSCT instructions) perform comparison and output the comparison results when the relevant high-speed counting operation. These instructions have limitations on the number of simultaneously driven instructions as shown in the following table. The HSCT instruction can only be used once in any program.

When the output relay (Y) has been designated for comparison results, the ON/OFF status of the output is affected directly until END instruction output is refreshed.

When the PLC is a relay output type, a mechanical delay in operation (approx. 10ms) is caused. Therefore, use a transistor output type PLC.

Applied instruction	Limitation in number of instructions driven at same time
HSCS	32 instructions including HSCT instruction
HSCR	
HSZ* ¹	
HSCT* ¹	Only 1 (This instruction can only be used once.)

- *1. When HSZ or HSCT instruction is used, the maximum response frequencies and overall frequency of all software counters becomes limited.

→ For the maximum response frequencies and overall frequency of software counters, refer to Section 11.9.

11.8 Conditions for Hardware Counter to be Handled as Software Counter

The high-speed counters are classified into hardware counters and software counters. Some hardware counters are handled as software counters depending on the operating conditions. In this case, use hardware counters within the range of maximum response frequency and total frequency determined for software counters.

11.8.1 Conditions under which counters are handled as software counters

The hardware counters can perform counting with the hardware of FX3U regardless of the overall frequency. However, under the following conditions, they are handled as software counters. When using them in the condition below, the maximum response frequencies and overall frequency of the counters are considered to be the same as those of other software counters.

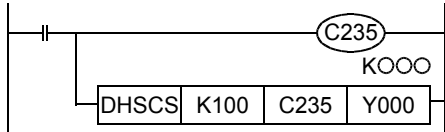
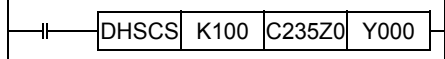
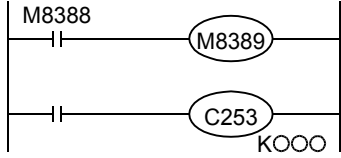
Hardware counter No.	Conditions under which counters are handled as software counters
	<p>When DHSCS (FNC 53), DHSCR (FNC 54), DHSZ (FNC 55) or DHSCT (FNC280) instruction is used for a hardware counter number, the hardware counter is handled as a software counter. Ex.: C235</p> 
<p>C235 C236 C237 C238 C239 C240 C244(OP) C245(OP) C246 C248(OP) C251 C253</p>	<p>In this case, C235 works as a software counter.</p> <p>When the index register is used for the counter number designated by DHSCS (FNC 53), DHSCR (FNC 54), DHSZ (FNC 55) or DHSCT (FNC280) instruction, all hardware counters are handled as software counters. Ex.: C235Z0</p> 
	<p>When the logic is reversed by the external rest input signal logic change function, C253 (hardware counter) is switched to a software counter. Ex.: The logic of the external reset input signal of C253 is inverted. → For the inversion of the logic of external reset input signal, refer to Subsection 11.11.2.</p> 

11.8.2 Method of confirming operation status of counters

The high-speed counter mode, hardware or software, can be confirmed by checking whether the operation status (M8380 to M8387) is on or off.

→ **For the list of operation status of high-speed counters, refer to Subsection 11.11.1.**

11	High-Speed Counters
12	Output Wiring
13	Wiring for Various Uses
14	Test Run, Maintenance, Troubleshooting
15	Input/Output Powered Extension Units
16	Input/Output Extension Blocks
17	Extension Power Supply Unit
18	Other Extension Units and Options
19	Display Module
20	Terminal Block

11.9 Calculation of Response Frequency and Overall Frequency

11.9.1 Response frequencies of hardware counters

The maximum response frequencies of the hardware counters are shown in the following table. Depending on the working conditions, the maximum response frequencies of hardware counters are the same as those of the software counters, and limitations on overall frequency are set up.

→ For the conditions under which the hardware counters are handled as software counters, refer to the previous page.

Counter type	Counter Nos.	Max. response frequency		
		Main unit	FX3U-4HSX-ADP	
1-phase 1-count input	C235,C236,C237,C238,C239,C240	100kHz	200kHz	
	C244(OP),C245(OP)	10kHz		
1-phase 2-count input	C246,C248(OP)	100kHz		
2-phase 2-count input	1 edge count 4 edge count	C251,C253	50kHz	100kHz
			50kHz	100kHz

11.9.2 Response frequencies and overall frequency of software counters

The maximum response frequencies and overall frequency of software counters are shown below. When HSZ or HSCT instruction is used in the program, limitations are put on the maximum response frequencies and overall frequency of all software counters regardless of the instruction operand. When examining the system or creating the program, use the counters within the maximum response frequency and overall frequency ranges suitable to the conditions in consideration of the limitations.

1. When FX3U Series special function units/blocks and analog special adapters are not used

Examples of calculation are given in the heavy-line frame.

Counter type	Counter Nos.	Software counters with HSCS, HSCR, HSZ or HSCT instruction*1	Magnification for calculation of overall frequency	Response frequency and overall frequency depending on conditions of instruction to be used							
				Neither HSZ nor HSCT instruction		Only HSCT instruction		Only HSZ instruction		Both HSZ and HSCT instructions	
				Max. response frequency (kHz)	Overall frequency (kHz)	Max. response frequency (kHz)	Overall frequency (kHz)	Max. response frequency (kHz)	Overall frequency (kHz)	Max. response frequency (kHz)	Overall frequency (kHz)
1-phase 1-count input	C241, C242, C243, C244, C245	C235, C236, C237, C238, C239, C240	□×1	40	80	30	60	40 - (number of instruction) *2	80 - 1.5 × (number of instruction)	30 - (number of instruction) *2	60 - 1.5 × (number of instruction)
	-	C244(OP), C245(OP)	×1	10		10					
1-phase 2-count input	C247, C248, C249, C250	C246, C248(OP)	×1	40		30					
2-phase 2-count input	1 edge count	C252, C253 (OP), C254, C255	×1	40		30		(40 - number of instruction) / 4		(30 - number of instruction) / 4	
	4 edge count	C251, C253		×4	10	7.5					

*1. When an index register is added to a counter number specified by HSCS, HSCR, HSZ or HSCT instruction, all hardware counters are switched to software counters.

*2. The high-speed counters C244(OP) and C245(OP) cannot count signals of 10kHz or more.

- 1) Calculation of overall frequency
The overall frequency is calculated by the high-speed comparison instruction used in the program based on the above table.

Overall frequency ≥ Sum of "response frequency of high-speed counter × Magnification for calculation of overall frequency"

- 2) Example of calculation
When only HSZ instruction is used six times in a program, the frequency is calculated by the formulas shown in the "Only HSZ instruction" column in the above table.

High-speed counter No. to be used		Input frequency	Calculation of max. response frequency	Magnification for calculation of overall frequency	Instruction to be used
C237	Operation as software counter	30kHz	40 - 6(times) = 34kHz	×1	HSZ instruction is used six times.
C241	Software counter	20kHz	40 - 6(times) = 34kHz	×1	
C253(OP) [4 edge count]		4kHz	{40 - 6(times)} / 4 = 8.5kHz	×4	

- 1) The overall frequency is calculated as shown below because HSZ instruction is used six times.

$$\text{Overall frequency} = 80 - 1.5 \times 6 = \underline{71\text{kHz}}$$

- 2) The sum of the response frequencies of the high-speed counters used is calculated as shown below.

$$"30\text{kHz} \times 1[\text{C237}]" + "20\text{kHz} \times 1[\text{C241}]" + "4\text{kHz} \times 4[\text{C253(OP)}]" = 66\text{kHz} \leq \underline{71\text{kHz}}$$

2. When FX3U Series special function units/blocks and analog special adapters are used

Counter type	Counter Nos.	Software counters with HSCS, HSCR, HSZ or HSCT instruction *1	Magnification for calculation of overall frequency	Response frequency and overall frequency depending on conditions of instruction to be used							
				Neither HSZ nor HSCT instruction		Only HSCT instruction		Only HSZ instruction		Both HSZ and HSCT instructions	
				Max. response frequency (kHz)	Overall frequency (kHz)	Max. response frequency (kHz)	Overall frequency (kHz)	Max. response frequency (kHz)	Overall frequency (kHz)	Max. response frequency (kHz)	Overall frequency (kHz)
1-phase 1-count input	C241, C242, C243, C244, C245	C235, C236, C237, C238, C239, C240	×1	30	60	25	50	30 - (number of instructions) *2	50 - 1.5 × (number of instructions)	25 - (number of instructions) *2	50 - 1.5 × (number of instructions)
	—	C244(OP), C245(OP)	×1	10		10					
1-phase 2-count input	C247, C248, C249, C250	C246, C248(OP)	×1	30		25					
2-phase 2-count input	1 edge count	C252, C253(OP), C254, C255	×1	30	6.2	25	(30 - number of instructions) / 4	(25 - number of instructions) / 4			
	4 edge count	C251, C253		×4		7.5					

*1. When an index register is added to a counter number specified by HSCS, HSCR, HSZ or HSCT instruction, all hardware counters are switched to software counters.

*2. The high-speed counters C244(OP) and C245(OP) cannot count signals of 10 kHz or more.

11	High-Speed Counters
12	Output Wiring
13	Wiring for Various Uses
14	Test Run, Maintenance, Troubleshooting
15	Input/Output Powered Extension Units
16	Input/Output Extension Blocks
17	Extension Power Supply Unit
18	Other Extension Options
19	Display Module
20	Terminal Block

- 1) Calculation of overall frequency
 The overall frequency is calculated by the high-speed comparison instruction used in the program based on the above table.

Overall frequency ≥ Sum of "response frequency of high-speed counter × Magnification for calculation of overall frequency"

- 2) Example of calculation
 When only HSZ instruction is used six times in a program, the frequency is calculated by the formulas shown in the "Only HSZ instruction" column in the above table.

High-speed counter No. to be used		Input frequency	Calculation of max. response frequency	Magnification for calculation of overall frequency	Instruction to be used
C237	Operation as software counter	20kHz	30 - 6(times) = 24kHz	×1	HSZ instruction is used six times.
C241	Software counter	10kHz	30 - 6(times) = 24kHz	×1	
C253(OP) [4 edge count]		2kHz	{30 - 6(times)} / 4 = 6kHz	×4	

- 1) The overall frequency is calculated as shown below because HSZ instruction is used six times.

$$\text{Overall frequency} = 50 - 1.5 \times 6 = \underline{41\text{kHz}}$$

- 2) The sum of the response frequencies of the high-speed counters used is calculated as shown below.

$$"20\text{kHz} \times 1[\text{C237}]" + "10\text{kHz} \times 1[\text{C241}]" + "2\text{kHz} \times 4[\text{C253(OP)}]" = 38\text{kHz} \leq \underline{41\text{kHz}}$$

11.10 Examples of External Wiring (Rotary Encoder)

11.10.1 1-phase 1-input [C235 to C245]

The following examples of wiring apply to the cases where C235 is used. When another high-speed counter number is used, wire the counter referring to the following diagrams.

1. When the input terminals of the main unit are used

When pulses with a response frequency of 50 kHz to 100 kHz are captured to the high-speed counter using the input terminals X000 to X005, wire the counter as stated below.

- The wiring length should be 5m (16'4") or less.
- As connecting cables, use shielded twisted-pair cables. Ground the shield of each shielded cable only on the PLC side.
- Connect a bleeder resistance of 1.5kΩ (1W or more) to the input terminal, so that the sum of the load current of the open collector transistor output on the mating device side and the input current of the main unit is 20 mA or more.

1) NPN open collector transistor output rotary encoder

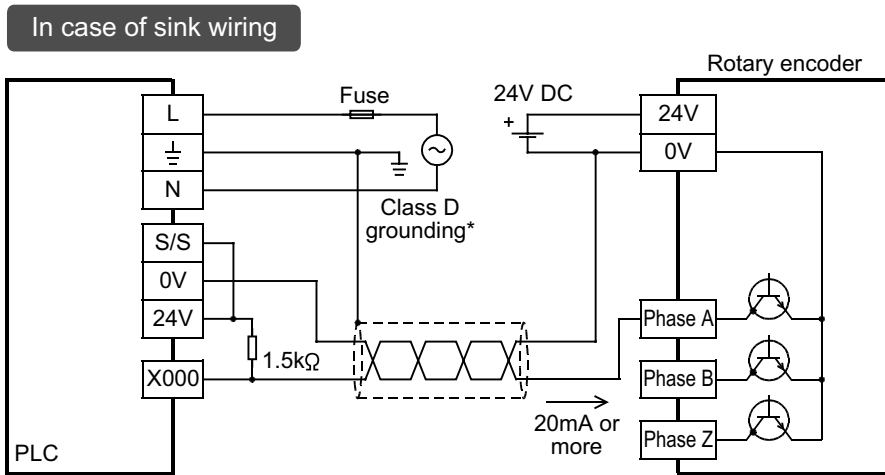

* The grounding resistance should be 100Ω or less.

2) PNP open collector transistor output rotary encoder

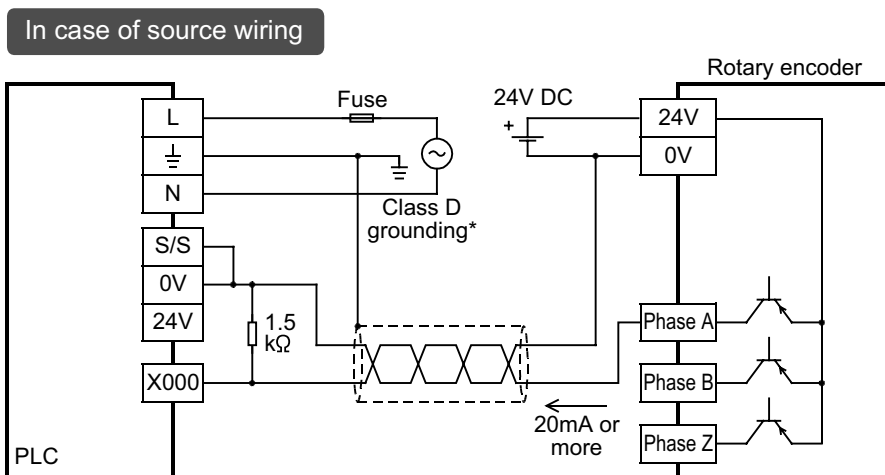

* The grounding resistance should be 100Ω or less.

11	High-Speed Counters
12	Output Wiring
13	Wiring for Various Uses
14	Test Run, Maintenance, Troubleshooting
15	Input/Output Powered Extension Units
16	Input/Output Extension Blocks
17	Extension Power Supply Unit
18	Other Extension Units and Options
19	Display Module
20	Terminal Block

2. When high-speed input special adapter (FX3U-4HSX-ADP) is used

1) Differential line driver output rotary encoder

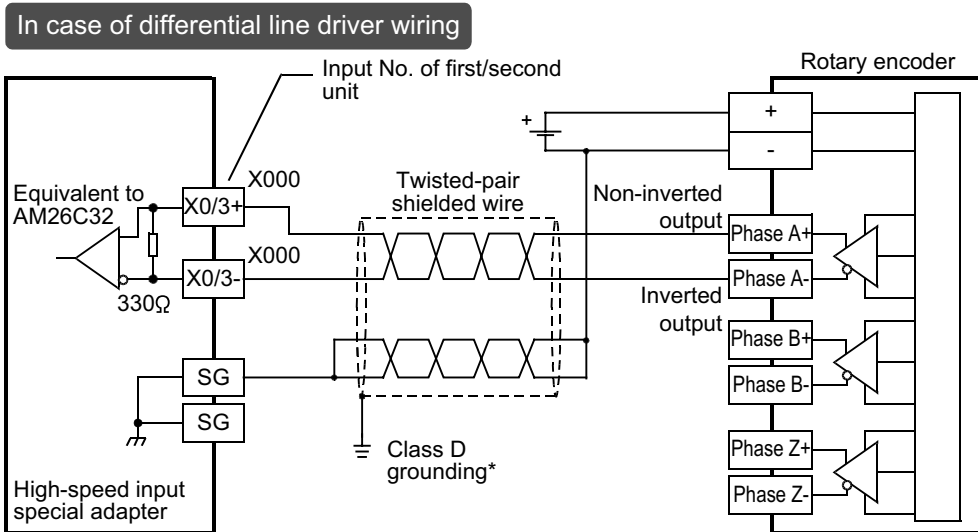

* The grounding resistance should be 100Ω or less.

11.10.2 2-phase 2-input [C251 to C255]

The following examples of wiring apply to the cases where C251 is used. When another high-speed counter number is used, wire the counter referring to the following diagrams.

1. When the input terminals of the main unit are used

When pulses with a response frequency of 50 kHz to 100 kHz are captured to the high-speed counter using the input terminals X000 to X005, wire the counter as stated below.

- The wiring length should be 5m (16'4") or less.
- For connecting cables, use shielded twisted-pair cables. Ground the shield of each shielded cable only on the PLC side.
- Connect a bleeder resistance of 1.5kΩ (1W or more) to the input terminal, so that the sum of the load current of the open collector transistor output on the mating device side and the input current of the main unit is 20mA or more.

1) NPN open collector transistor output rotary encoder

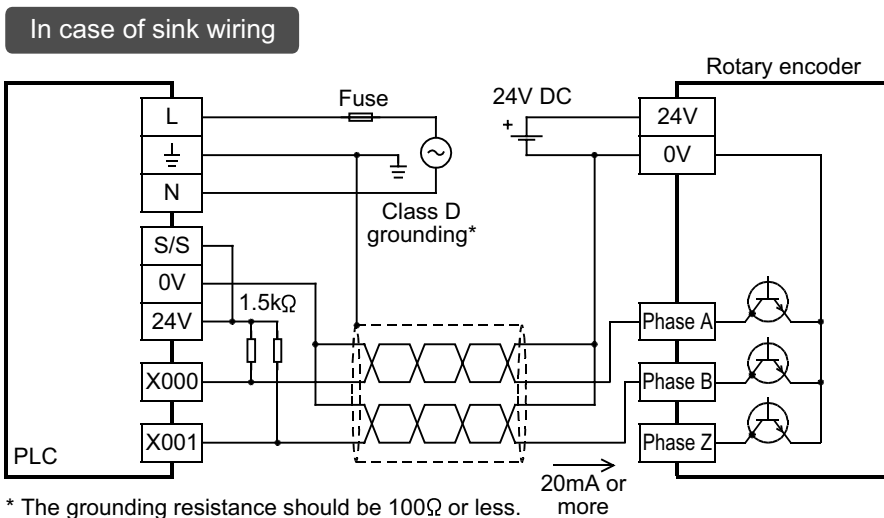

* The grounding resistance should be 100Ω or less. 20mA or more

2) PNP open collector transistor output rotary encoder

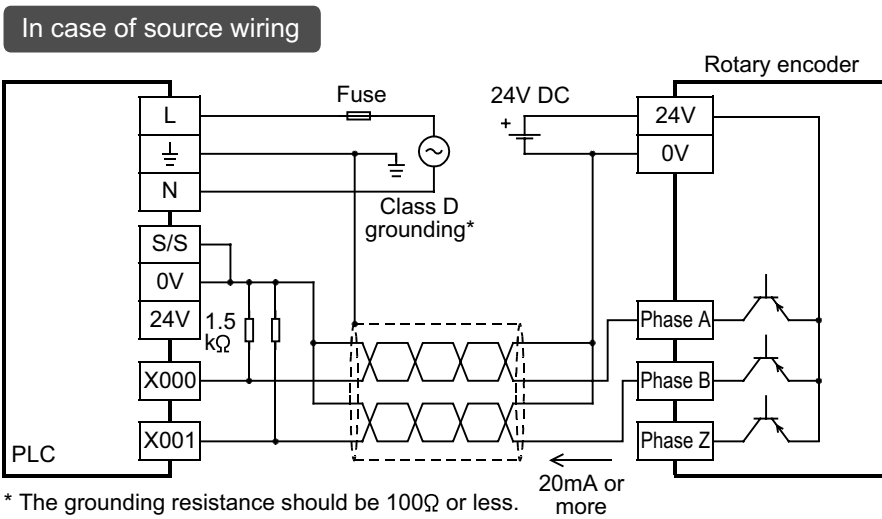

2. When high-speed input special adapter (FX3U-4HSX-ADP) is used

1) Differential line driver output rotary encoder

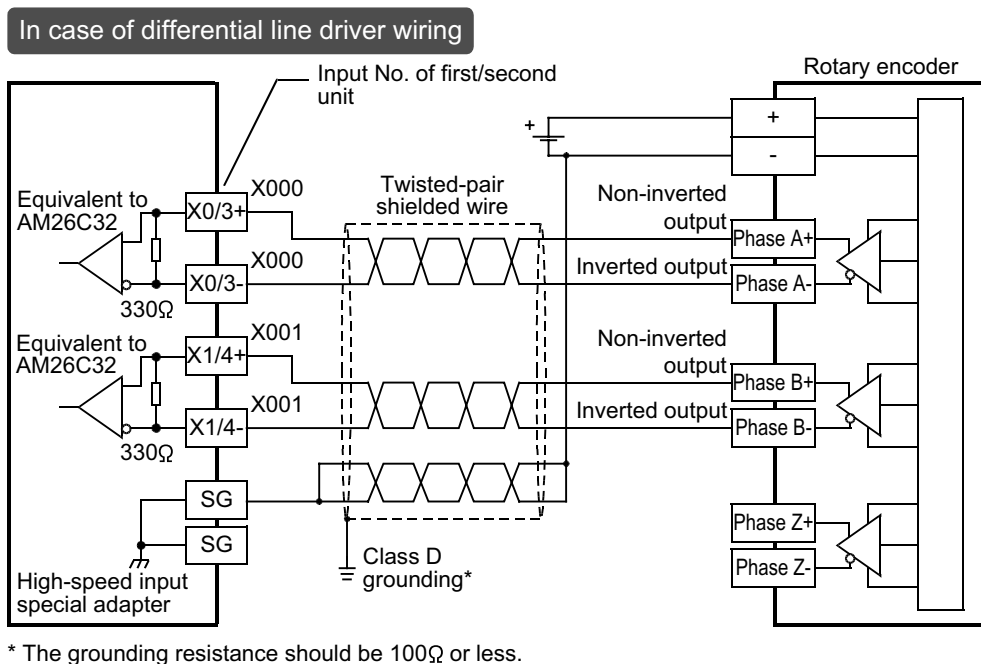

11.10.3 Cautions for the other side device

Encoders having the output forms shown in the following table can be connected to the terminals. (The encoders may not function correctly depending on electrical compatibility. Check the specifications in advance.)

Voltage output type encoders and absolute encoders cannot be connected to the high-speed counter input terminals.

Terminal for connecting	Output form that can be directly connected
Input terminals of main unit	Open collector transistor output form (applicable to 24V DC)
Input terminals of FX3U-4HSX-ADP	Differential line driver output form Set the input voltage of FX3U-4HSX-ADP to 5V DC or less.

11 High-Speed Counters

12 Output Wiring

13 Wiring for Various Uses

14 Test Run, Maintenance, Troubleshooting

15 Input/Output Powered Extension Units

16 Input/Output Extension Blocks

17 Extension Power Supply Unit

18 Other Extension Units and Options

19 Display Module

20 Terminal Block

11.11 Related Devices and Function Switching Procedures

11.11.1 Related devices

1. For switching 1-phase 1-count input counter mode to up-count or down-count

Counter type	Counter No.	Specifying device	Up-counting	Down-counting
1-phase 1-count input	C235	M8235	OFF	ON
	C236	M8236		
	C237	M8237		
	C238	M8238		
	C239	M8239		
	C240	M8240		
	C241	M8241		
	C242	M8242		
	C243	M8243		
	C244	M8244		
C245	M8245			

2. For monitoring of up-count/down-count counting direction of 1-phase 2-count input and 2-phase 2-count input counters

Counter type	Counter No.	Monitoring device	OFF	ON	Counter type	Counter No.	Monitoring device	OFF	ON
1-phase 2-count input	C246	M8246	Up-counting	Down-counting	2-phase 2-count input	C251	M8251	Up-counting	Down-counting
	C247	M8247							
	C248	M8248							
	C249	M8249							
	C250	M8250							
						C252	M8252		
						C253	M8253		
						C254	M8254		
						C255	M8255		

3. For switching high-speed counter function

Device No.	Name	Description	Reference
M8388	Contact for changing high-speed counter function	Contact for changing the high-speed counter function	-
M8389	Function switching devices	Switching of logic of external reset input	Subsection 11.11.2
M8390		Function switching device for C244	Subsection 11.11.3
M8391		Function switching device for C245	Subsection 11.11.3
M8392		Function switching device for C248 and 253	Subsection 11.11.3
M8198		Device for switching C251, C252 and C254 to single or 4 edge count	Subsection 11.11.4
M8199		Device for switching C253, C255 and C253 (OP) to single or 4 edge count	Subsection 11.11.4

4. Operation status of hardware counter/software counter

Device No.	Name	Description	ON	OFF
M8380*1	Operation status	Operation status of C235, C241, C244, C246, C247, C249, C251, C252 and C254	Software counter	Hardware counter
M8381*1		Operation status of C236		
M8382*1		Operation status of C237, C242 and C245		
M8383*1		Operation status of C238, C248, C248(OP), C250, C253 and C255		
M8384*1		Operation status of C239 and C243		
M8385*1		Operation status of C240		
M8386*1		Operation status of C244(OP)		
M8387*1		Operation status of C245(OP)		

*1. To be cleared when the device turns RUN from STOP.

11	High-Speed Counters
12	Output Wiring
13	Wiring for Various Uses
14	Test Run, Maintenance, Troubleshooting
15	Input/Output Powered Extension Units
16	Input/Output Extension Blocks
17	Extension Power Supply Unit
18	Other Extension Units and Options
19	Display Module
20	Terminal Block

11.11.2 [Function switching] switching of logic of external reset input signal

The external reset input for the counters C241 to C245, C247 to C250 and C252 to C255 resets the counters when it is turned ON. If the logic is inverted by the following program, the counters can be reset by turning OFF the input.

Counter No.	Inversion of logic of external reset input signal	Details of change
C241 to C245 C247 to C250 C252 to C255		The logic of external reset input is inverted to reset the counters when the input is turned OFF. (The logic for all applicable counter numbers is inverted.)

Cautions on inverting the logic of the external reset input signal

Although C253 is a hardware counter, it is switched to a software counter by inverting the logic of the external reset input signal.

11.11.3 [Function switching] switching of allocation and functions of input terminals

When the software counters C244, C245, C248 and C253 are combined with the following special auxiliary relays, the allocation of the input terminals and functions are changed. Program the special auxiliary relays just before the counters.

Counter No.	Function switching method	Details of change
C244(OP)		<ul style="list-style-type: none"> The count input terminal is changed from X000 to X006. Reset input is not given. Start input is not given. The counter functions as a hardware counter.
C245(OP)		<ul style="list-style-type: none"> The count input terminal is changed from X002 to X007. Reset input is not given. Start input is not given. The counter functions as a hardware counter.
C248(OP)		<ul style="list-style-type: none"> Reset input is not given. The counter functions as a hardware counter.
C253(OP)		<ul style="list-style-type: none"> Reset input is not given. The counter functions as a software counter.

11.11.4 [Function switching] procedures for using 2-phase 2-count input counters C251 to C255 in 4 edge count mode

The 2-phase 2-count input counters C251 to C255 are in the 1 edge count mode. The counters can be operated in the 4 edge count mode by programming as shown below.

Counter No.	To use 4 edge count 2-phase 2-input counter	Details of change
C251		1 edge count (before change)
C252		
C253		
C253(OP)		4 edge count (after change)
C254		
C255		

11	High-Speed Counters
12	Output Wiring
13	Wiring for Various Uses
14	Test Run, Maintenance, Troubleshooting
15	Input/Output Powered Extension Units
16	Input/Output Extension Blocks
17	Extension Power Supply Unit
18	Other Extension Units and Options
19	Display Module
20	Terminal Block

11.12 Cautions on Use

→ For programming details, refer to the Programming Manual.

- If the operation of a high-speed counter is triggered by a device such as a switch, the counter may malfunction due to extra noise from switch chattering or contact bounce.
- The input filter of an input terminal for a high-speed counter in the main unit is automatically set to 5 μ s (X000 to X005) or 50 μ s (X006 and X007).
Accordingly, it is not necessary to use the REFF instruction or special data register D8020 (input filter adjustment).
The input filter for input relays not being used for high-speed counters remains at 10 ms (initial value).
- The inputs X000 to X007 are used for high-speed counters, input interrupt, pulse catch, SPD/DSZR/DVIT/ZRN instructions and general-purpose inputs. There should be no overlap between each input number.
For example, when C251 is used, X000 and X001 are occupied. As a result, "C235, C236, C241, C244, C246, C247, C249, C252 and C254", "input interrupt pointers I00* and I10**", "pulse catch contacts M8170 and M8171" and "SPD instruction using X000 and/or X001" cannot be used.
- Make sure that the signal speed for high-speed counters does not exceed the response frequency described above. If an input signal exceeds the response frequency, a WDT error may occur, or the communication functions such as a parallel link may malfunction.
- The response frequency changes depending on number of used counters, but the input filter value is fixed to 5 μ s (X000 to X005) or 50 μ s (X006 and X007).
Note that noise above the response frequency may be counted depending on the filter value of the used input.

12. Output Wiring Procedures

DESIGN PRECAUTIONS



- Make sure to have the following safety circuits outside of the PLC to ensure safe system operation even during external power supply problems or PLC failure. Otherwise, malfunctions may cause serious accidents.
 - 1) Most importantly, have the following: an emergency stop circuit, a protection circuit, an interlock circuit for opposite movements (such as normal vs. reverse rotation), and an interlock circuit (to prevent damage to the equipment at the upper and lower positioning limits).
 - 2) Note that when the PLC CPU detects an error, such as a watchdog timer error, during self-diagnosis, all outputs are turned off. Also, when an error that cannot be detected by the PLC CPU occurs in an input/output control block, output control may be disabled. External circuits and mechanisms should be designed to ensure safe machinery operation in such a case.
 - 3) Note that the output current of the 24V DC service power supply varies depending on the model and the absence/presence of extension blocks. If an overload occurs, the voltage automatically drops, inputs in the PLC are disabled, and all outputs are turned off. External circuits and mechanisms should be designed to ensure safe machinery operation in such a case.
 - 4) Note that when an error occurs in a relay, triac or transistor output device, the output could be held either on or off. For output signals that may lead to serious accidents, external circuits and mechanisms should be designed to ensure safe machinery operation in such a case.

DESIGN PRECAUTIONS



- Do not bundle the control line together with or lay it close to the main circuit or power line. As a guideline, lay the control line at least 100mm (3.94") or more away from the main circuit or power line. Noise may cause malfunctions.
- Install module so that excessive force will not be applied to peripheral device connectors. Failure to do so may result in wire damage/breakage or PLC failure.

WIRING PRECAUTIONS



- Make sure to cut off all phases of the power supply externally before attempting installation or wiring work. Failure to do so may cause electric shock or damage to the product.
- Make sure to attach the terminal cover, offered as an accessory, before turning on the power or initiating operation after installation or wiring work. Failure to do so may cause electric shock.

11	High-Speed Counters
12	Output Wiring
13	Wiring for Various Uses
14	Test Run, Maintenance, Troubleshooting
15	Input/Output Powered Extension Units
16	Input/Output Extension Blocks
17	Extension Power Supply Unit
18	Other Extension Units and Options
19	Display Module
20	Terminal Block

WIRING PRECAUTIONS



- Do not supply power to the [24+] and [24V] terminals (24V DC service power supply) on the main unit or extension units.
Doing so may cause damage to the product.
- Perform class D grounding (grounding resistance: 100 Ω or less) to the grounding terminal on the main unit and extension units with a wire 2 mm² or thicker.
Do not use common grounding with heavy electrical systems (refer to Section 9.4).
- Connect the AC power supply wiring to the dedicated terminals described in this manual.
If an AC power supply is connected to a DC input/output terminal or DC power supply terminal, the PLC will burn out.
- Connect the DC power supply wiring to the dedicated terminals described in this manual.
If an AC power supply is connected to a DC input/output terminal or DC power supply terminal, the PLC will burn out.
- Do not wire vacant terminals externally.
Doing so may damage the product.
- When drilling screw holes or wiring, make sure that cutting and wiring debris do not enter the ventilation slits.
Failure to do so may cause fire, equipment failures or malfunctions.
- Make sure to properly wire the FX3U Series main unit and FX0N/FX2N/FX3U Series extension equipment in accordance with the following precautions.
Failure to do so may cause electric shock, equipment failures, a short-circuit, wire breakage, malfunctions, or damage to the product.
 - The disposal size of the cable end should follow the dimensions described in the manual.
 - Tightening torque should follow the specifications in the manual.
- Make sure to properly wire to the terminal block (European type) in accordance with the following precautions.
Failure to do so may cause electric shock, equipment failures, a short-circuit, wire breakage, malfunctions, or damage to the product.
 - The disposal size of the cable end should follow the dimensions described in the manual.
 - Tightening torque should follow the specifications in the manual.
 - Twist the end of strand wire and make sure that there are no loose wires.
 - Do not solder-plate the electric wire ends.
 - Do not connect more than the specified number of wires or electric wires of unspecified size.
 - Affix the electric wires so that neither the terminal block nor the connected parts are directly stressed.
- Make sure to properly wire to the FX Series terminal blocks in accordance with the following precautions.
Failure to do so may cause electric shock, equipment failures, a short-circuit, wire breakage, malfunctions, or damage to the product.
 - The disposal size of the cable end should follow the dimensions described in the manual.
 - Tightening torque should follow the specifications in the manual.

This chapter explains the procedures for wiring the output terminals.

- Wiring procedures
- Procedures for cabling according to shape of output terminal
- Output wiring procedures

12.1 Sink and Source Output (Transistor)

FX3U Series main units and FX2N Series input/output extension units/blocks of transistor sink output type and of transistor source output type are available.

1. Differences in circuit

- Sink output [-common]
Output to make load current flow into the output (Y) terminal is called sink output.

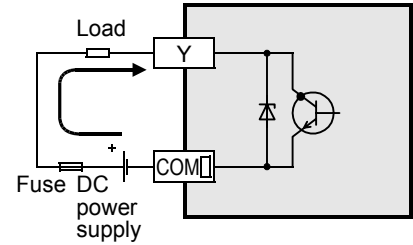

- Source output [+common]
Output to make load current flow out of the output (Y) terminal is called source output.

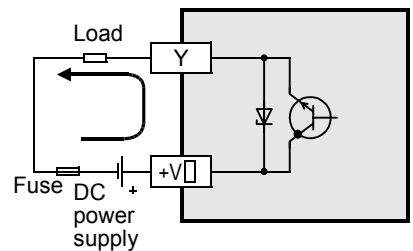

12.2 External Wiring for Relay Output

This section explains the relay output specifications (main unit) and external wiring.

- For the main unit, refer to Subsection 12.2.1 "Output specifications (main unit) relay output", Subsection 12.2.3 "Handling of relay output", Subsection 12.2.4 "External wiring precautions" and Subsection 12.2.5 "Example of external wiring" in this section.
- For the input/output powered extension units/blocks, refer to Subsection 12.2.3 "Handling of relay output" and Subsection 12.2.4 "External wiring precautions" in this section. For their specifications and examples of wiring, refer to the specification for each model.
 - For the specifications on the input/output powered extension unit, refer to Chapter 15.
 - For the specifications on the input/output extension block, refer to Chapter 16.

12.2.1 Output specifications (main unit) relay output

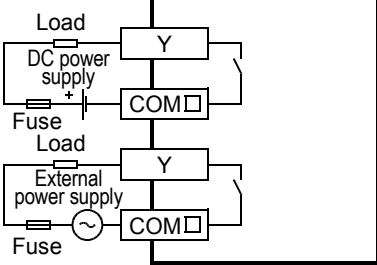
Item	Relay output specifications					
	FX3U-16MR/ □S	FX3U-32MR/ □S FX3U-32MR/ UA1	FX3U-48MR/ □S	FX3U-64MR/ □S FX3U-64MR/ UA1	FX3U-80MR/ □S	FX3U-128MR/ ES
Number of output points	8 points	16 points	24 points	32 points	40 points	64 points
Output connecting type	Fixed terminal block (M3 screw)	Removable terminal block (M3 screw)				
Output form	Relay					
External power supply	30V DC or less or 240V AC or less (250V AC or less when the unit does not comply with CE, UL or cUL standards)					
Max. load	Resistance load	2 A/point The total load current of resistance loads per common terminal should be the following value. → For details on the common terminal for each model, refer to the terminal block layout. <ul style="list-style-type: none"> • 1 output point/common terminal: 2 A or less • 4 output points/common terminal: 8 A or less • 8 output points/common terminal: 8 A or less 				
	Inductive load	80 VA → For the product life, refer to Subsection 12.2.2. → For cautions on external wiring, refer to Subsection 12.2.4.				
Min. load	5V DC, 2mA (reference value)					
Open circuit leakage current	-					
Response time	OFF→ON	Approx. 10ms				
	ON→OFF	Approx. 10ms				
Circuit insulation	Mechanical insulation					
Display of output operation	LED on panel lights when power is applied to relay coil.					
Output circuit configuration	 <p>A common number applies to the □ of [COM □].</p>					

Number of output points per common terminal

- On FX3U-16MR/□S, one common terminal is used for one output point.
- On models other than FX3U-16MR/□S, one common terminal is used for four or eight output points.

12.2.2 Product life of relay contacts

→ For product life of relay contacts, refer to Subsection 4.4.2.

12.2.3 Handling of relay output

1. Output terminal

One common terminal is used for 1, 4 or 8 relay output points. The common terminal blocks can drive loads of different circuit voltage systems (for example, 200V AC, 100V AC and 24V DC).

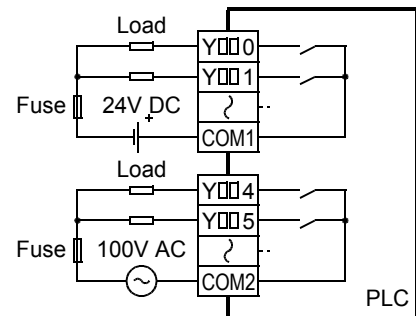

2. External power supply

Use an external power supply of 30V DC or less or 240V AC or less (250V AC or less when the unit does not comply with CE, UL or cUL standards) for loads.

3. Circuit insulation

The PLC internal circuit and external load circuits are electrically insulated between the output relay coil and contact. The common terminal blocks are separated from one another.

4. Display of operation

When power is applied to the output relay coil, the LED is lit, and the output contact is turned on.

5. Response time

The response time of the output relay from when the power is applied to the coil until the output contact is turned on and from when the coil is shut off until the output contact is turned off is approx. 10ms.

6. Output current

At a circuit voltage of 240V AC or less (250V AC or less when the unit does not comply with CE, UL or cUL standards), a resistance load of 2A per point or an inductive load of 80VA or less (100V AC or 200V AC) can be driven.

→ For the life of the contact for switching an inductive load, refer to Subsection 12.2.2.

When an inductive load is switched, connect a diode (for commutation) or a surge absorber in parallel with this load.

DC circuit	Diode (for commutation)
AC circuit	Surge absorber

7. Open circuit leakage current

When the output contact is turned off, no current leaks.

11

High-Speed
Counters

12

Output Wiring

13

Wiring for
Various Uses

14

Test Run,
Maintenance,
Troubleshooting

15

Input/Output
Powered
Extension Units

16

Input/Output
Extension
Blocks

17

Extension
Power Supply
Unit

18

Other Extension
Units and
Options

19

Display Module

20

Terminal Block

12.2.4 External wiring precautions

1. Protection circuit for load short-circuiting

A short-circuit at a load connected to an output terminal could cause burnout at the PCB. To prevent this, a protection fuse should be inserted at the output.

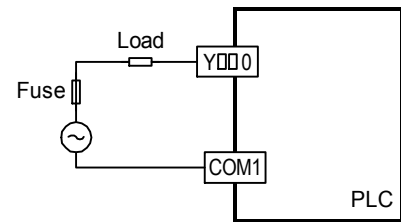

2. Contact protection circuit for inductive loads

An internal protection circuit for the relays is not provided for the relay output circuit in this product. It is recommended to use inductive loads with built-in protection circuits. When using loads without built-in protection circuits, insert an external contact protection circuit, etc. to reduce noise and extend the product life.

1) DC circuit

Connect a diode in parallel with the load.

The diode (for commutation) must comply with the following specifications.

Item	Guide
Reverse voltage	5 to 10 times the load voltage
Forward current	Load current or more

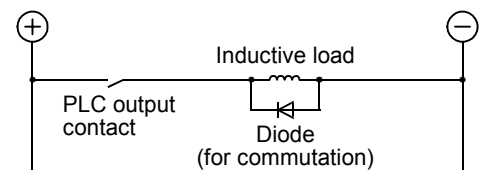

2) AC circuit

Connect the surge absorber (combined CR components such as a surge killer and spark killer, etc.) parallel to the load.

Select the rated voltage of a surge absorber that is suitable for the load being used. Refer to the table below for other specifications.

Item	Guide
Electrostatic capacity	Approx. 0.1 μ F
Resistance value	Approx. 100 to 200 Ω

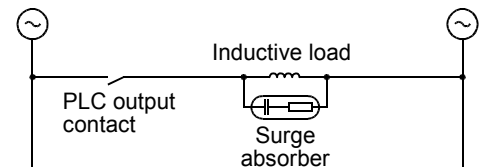

Reference

Manufacturer	Model name	Manufacturer	Model name
Okaya Electric Industries Co., Ltd.	CR-10201	Rubycon Corporation	250MCRA104100M B0325

3. Interlock

For loads such as forward/reverse contactors, etc., where a hazardous condition could result if switched ON simultaneously, an external interlock should be provided for interlocking the PLC's internal programs as shown to the right.

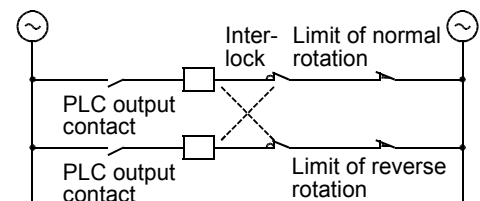

4. In-phase

PLC output contacts (*) should be used in an "in-phase" manner.

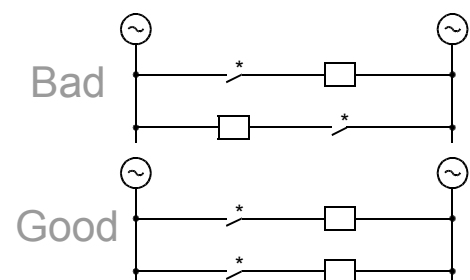

12.2.5 Example of external wiring

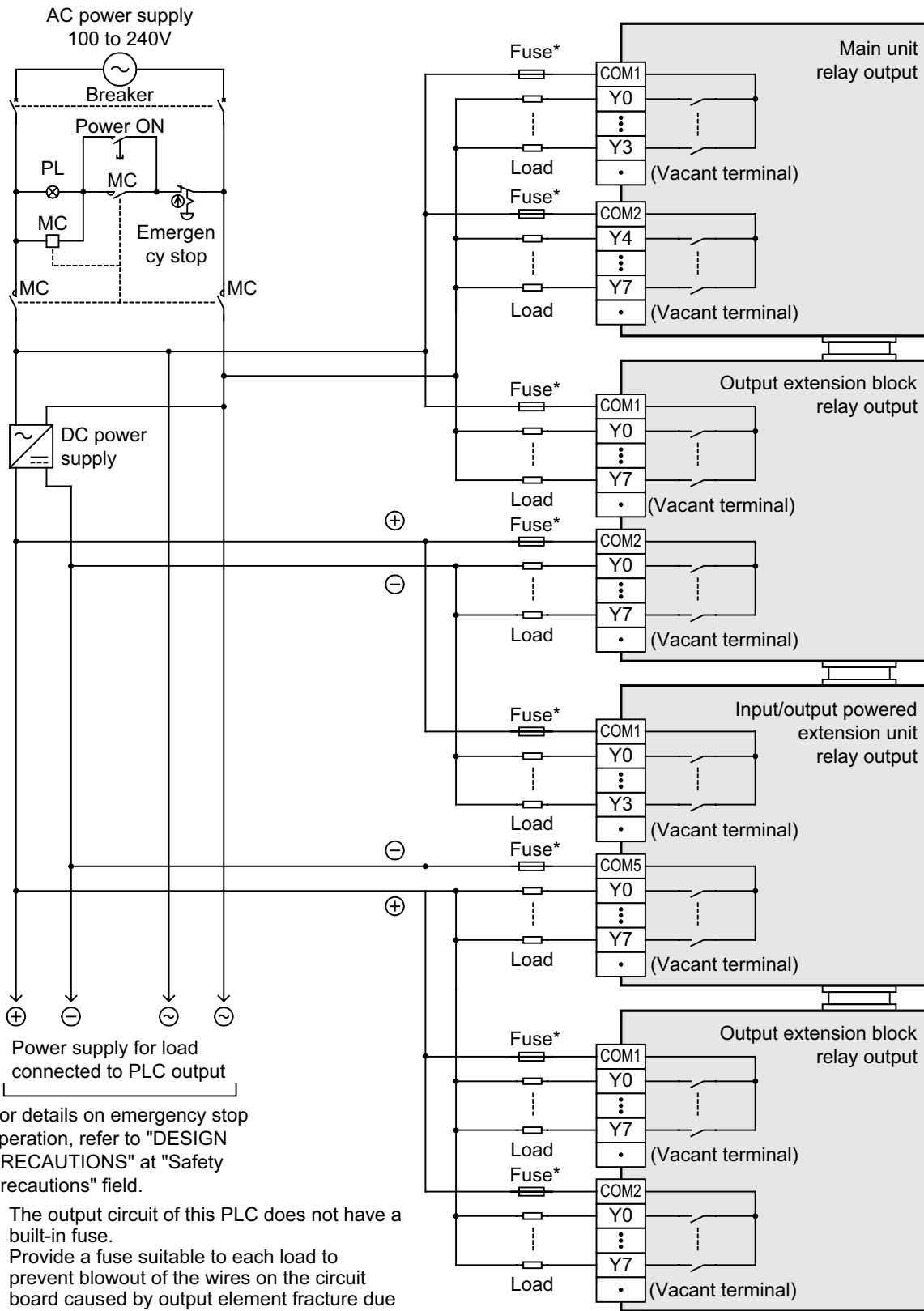

For details on emergency stop operation, refer to "DESIGN PRECAUTIONS" at "Safety Precautions" field.

* The output circuit of this PLC does not have a built-in fuse. Provide a fuse suitable to each load to prevent blowout of the wires on the circuit board caused by output element fracture due to load short-circuiting.

WIRING PRECAUTIONS	⚠ CAUTION
<ul style="list-style-type: none"> • Do not wire vacant terminals externally. Doing so may damage the product. 	

- 11 High-Speed Counters
- 12 Output Wiring
- 13 Wiring for Various Uses
- 14 Test Run, Maintenance, Troubleshooting
- 15 Input/Output Powered Extension Units
- 16 Input/Output Extension Blocks
- 17 Extension Power Supply Unit
- 18 Other Extension Units and Options
- 19 Display Module
- 20 Terminal Block

12.3 External Wiring of Transistor Output (Sink/Source) Type

This section explains the transistor output specifications (main unit) and external wiring.

- For the main unit, refer to Subsection 12.3.1 "Output specifications (main unit) transistor output (sink) type", Subsection 12.3.2 "Output specifications (main unit) transistor output (source) type", Subsection 12.3.3 "Handling of transistor output", Subsection 12.3.4 "External wiring precautions" and Subsection 12.3.5 "Example of external wiring".
- For the input/output powered extension units/blocks, refer to Subsection 12.3.3 "Handling of transistor output" and Subsection 12.3.4 "External wiring precautions" in this section. For the specifications and examples of wiring, refer to the specifications for each model.
 - **For the specifications on the input/output powered extension units, refer to Chapter 15.**
 - **For the specifications on the input/output extension blocks, refer to Chapter 16.**

12.3.1 Output specifications (main unit) transistor output (sink) type

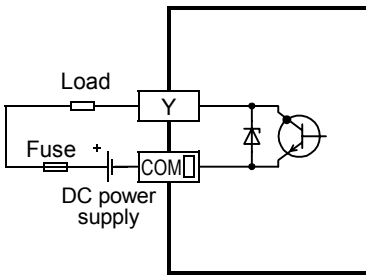
Item	Transistor output (sink) specifications					
	FX3U-16MT/ □S	FX3U-32MT/ □S	FX3U-48MT/ □S	FX3U-64MT/ □S	FX3U-80MT/ □S	FX3U-128MT/ ES
Number of output points	8 points	16 points	24 points	32 points	40 points	64 points
Connecting type	Fixed terminal block (M3 screw)	Removable terminal block (M3 screw)				
Output type/form	Transistor/sink output					
External power supply	5 to 30V DC					
Max. load	Resistance load	0.5A / point The total load current of resistance loads per common terminal should be the following value. → For details on the common terminal for each model, refer to the terminal block layout. <ul style="list-style-type: none"> 1 output point/common terminal: 0.5 A or less 4 output points/common terminal: 0.8 A or less 8 output points/common terminal: 1.6 A or less 				
	Inductive load	12W/24V DC The total of inductive loads per common terminal should be the following value. → For details on the common terminal for each model, refer to the terminal block layout. <ul style="list-style-type: none"> 1 output point/common terminal: 12W or less/24V DC 4 output points/common terminal: 19.2W or less/24V DC 8 output points/common terminal: 38.4W or less/24V DC 				
Open circuit leakage current	0.1 mA or less/30V DC					
ON voltage	1.5 V or less					
Min. load	-					
Response time	OFF→ON	Y000 to Y002:5 μs or less/10 mA or more (5 to 24V DC) Y003 or more:0.2 ms or less/200 mA or more (at 24V DC)				
	ON→OFF	Y000 to Y002:5 μs or less/10 mA or more (5 to 24V DC) Y003 or more:0.2 ms or less/200 mA or more (at 24V DC)				
Circuit insulation	Photocoupler insulation					
Display of output operation	LED on panel lights when photocoupler is driven.					
Output circuit configuration	 <p>A common number applies to the □ of [COM □].</p>					

Number of output points per common terminal

- On FX3U-16MT/□S, one common terminal is used for 1 output point.
- On models other than FX3U-16MT/□S, 1 common terminal is used for 4 or 8 output points.

12.3.2 Output specifications (main unit) transistor output (source) type

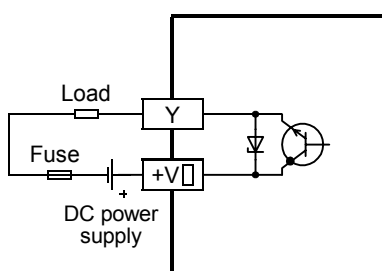
Item	Transistor output (source) specifications					
	FX3U-16MT/ □SS	FX3U-32MT/ □SS	FX3U-48MT/ □SS	FX3U-64MT/ □SS	FX3U-80MT/ □SS	FX3U-128MT/ ESS
Number of output points	8 points	16 points	24 points	32 points	40 points	64 points
Connecting type	Fixed terminal block (M3 screw)	Removable terminal block (M3 screw)				
Output type/form	Transistor/source output					
External power supply	5 to 30V DC					
Max. load	Resistance load	0.5A / point The total load current of resistance loads per common terminal should be the following value. → For details on the common terminal for each model, refer to the terminal block layout. <ul style="list-style-type: none"> 1 output point/common terminal: 0.5 A or less 4 output points/common terminal: 0.8 A or less 8 output points/common terminal: 1.6 A or less 				
	Inductive load	12W/24V DC The total of inductive loads per common terminal should be the following value. → For details on the common terminal for each model, refer to the terminal block layout. <ul style="list-style-type: none"> 1 output point/common terminal: 12W or less/24V DC 4 output points/common terminal: 19.2W or less/24V DC 8 output points/common terminal: 38.4W or less/24V DC 				
Open circuit leakage current	0.1 mA or less/30V DC					
ON voltage	1.5 V or less					
Min. load	-					
Response time	OFF→ON	Y000 to Y002:5 μs or less/10 mA or more (5 to 24V DC) Y003 or more:0.2 ms or less/200 mA or more (at 24V DC)				
	ON→OFF	Y000 to Y002:5 μs or less/10 mA or more (5 to 24V DC) Y003 or more:0.2 ms or less/200 mA or more (at 24V DC)				
Circuit insulation	Photocoupler insulation					
Display of output operation	LED on panel lights when photocoupler is driven.					
Output circuit configuration	 <p>A common number applies to the □ of [+V □].</p>					

Number of output points per common terminal

- On FX3U-16M/□SS, one common terminal is used for 1 output point.
- On models other than FX3U-16M/□SS, 1 common terminal is used for 4 or 8 output points.

12.3.3 Handling of transistor output

1. Output terminals

One, 4 or 8 transistor output points are covered by one common terminal.

Sink output

Connect each COM□ (number) terminal to the minus side of the load power supply.

The COM□ terminals are not connected internally.

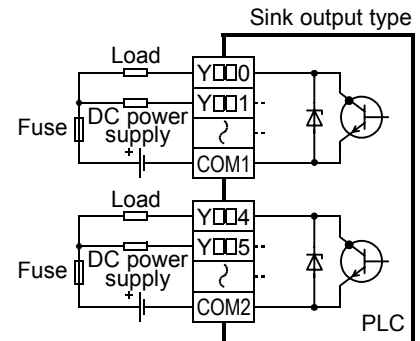

Source output

Connect each +V□ (number) terminal to the plus side of the load power supply.

The +V□ terminals are not connected internally.

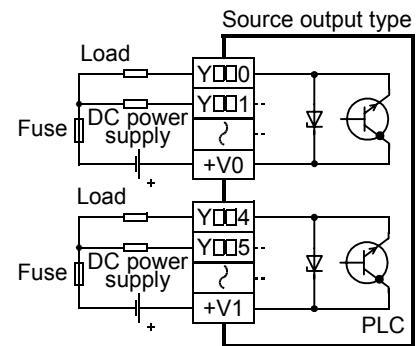

2. External power supply

For driving the load, use a smoothing power supply of 5 to 30V DC that can output current two or more times the rated current of the fuse connected to the load circuit.

3. Insulation of circuit

The internal circuit of the PLC and the output transistor are insulated with a photocoupler. The common blocks are separated from one another.

4. Display of operation

When any photocoupler operates, the corresponding LED is lit and corresponding output transistor turns ON.

11	High-Speed Counters
12	Output Wiring
13	Wiring for Various Uses
14	Test Run, Maintenance, Troubleshooting
15	Input/Output Powered Extension Units
16	Input/Output Extension Blocks
17	Extension Power Supply Unit
18	Other Extension Units and Options
19	Display Module
20	Terminal Block

5. Response time

The time from when the PLC drives (or shuts down) the photocoupler until the transistor is turned on (or off) is shown in the following table.

Classification		Response time	Load current	
Main unit	Y000 to Y002	5 μs or less	5 to 24V DC 10mA or more	When using an instruction related to pulse train output or positioning, make sure to set the load current to 10 to 100 mA (5 to 24V DC).
	Y003 or more	0.2 ms or less	24V DC 200 mA or more *1	
Input/output powered extension unit Output extension block		0.2ms or less	24V DC 200 mA *1	

*1. The transistor OFF time is longer under lighter loads.
For example, under a load of 24V DC 40mA, the response time is approx. 0.3ms. When response performance is required under light loads, provide a dummy resistance as shown to the right to increase the load current.

- Sink output type

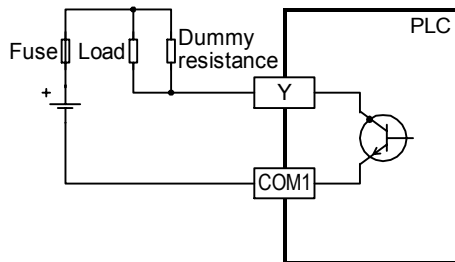

- Source output type

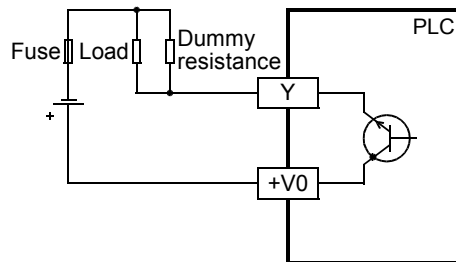

6. Output current

The maximum resistance loads for the input/output powered extension units and output extension blocks are shown in the following table.

The ON voltage of the output transistor is approx. 1.5V.

When driving a semiconductor element, carefully check the input voltage characteristics of the applied element.

Model	Output current	Limitation	
Main unit	0.5A/point	The total load current of resistance loads per common terminal should be the following value. 1 point/common: 0.5A or less 4 points/common: 0.8A or less 8 points/common: 1.6A or less	
			FX3U-16MT-ES(S)
			FX3U-32MT-ES(S)
			FX3U-48MT-ES(S)
			FX3U-64MT-ES(S)
			FX3U-80MT-ES(S)
Input/output powered extension units	0.5A/point	For FX2N-16EYT-C: 16 points/common: 1.6A or less	
			FX2N-32ET-ESS/UL
			FX2N-48ET-ESS/UL
			FX2N-48ET-DSS
			FX2N-32ET
			FX2N-48ET
Extension block	1A/point 0.3A/point	For FX2N-8EYT-H: 4 points/common: 2A or less	
			FX2N-48ET-D
			FX2N-16EYT-ESS/UL
			FX2N-8EYT-ESS/UL
			FX2N-16EYT
			FX2N-8EYT
FX2N-8EYT-H	1A/point	For FX2N-8EYT-H: 4 points/common: 2A or less	
FX2N-16EYT-C	0.3A/point		

7. Open circuit leakage current

0.1mA or less

12.3.4 External wiring precautions

1. Protection circuit for load short-circuits

A short-circuit at a load connected to an output terminal could cause burnout at the output element or the PCB. To prevent this, a protection fuse should be inserted at the output.

Use a load power supply capacity that is at least 2 times larger than the total rated fuse capacity.

- External Wiring of Sink Output Type

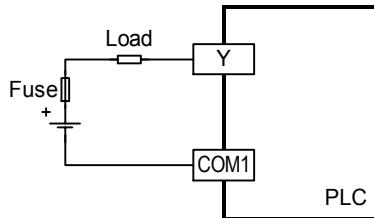

- External Wiring of Source Output Type

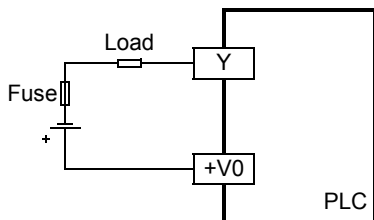

2. Interlock

For loads such as forward/reverse contactors, etc., where a hazardous condition could result if switched ON simultaneously, an external interlock should be provided for interlocking the PLC's internal programs, as shown below.

- External Wiring of Sink Output Type

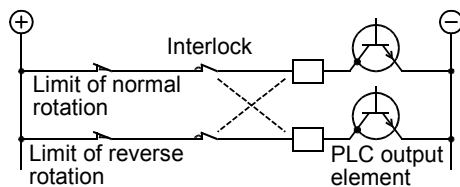

- External Wiring of Source Output Type

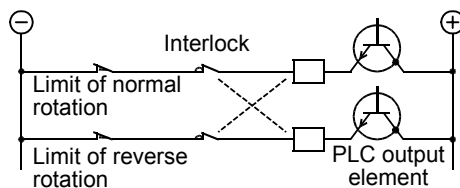

11	High-Speed Counters
12	Output Wiring
13	Wiring for Various Uses
14	Test Run, Maintenance, Troubleshooting
15	Input/Output Extension Units
16	Input/Output Extension Blocks
17	Extension Power Supply Unit
18	Other Extension Units and Options
19	Display Module
20	Terminal Block

3. Contact protection circuit for inductive loads

When an inductive load is connected, connect a diode (for commutation) in parallel with the load as necessary.

The diode (for commutation) must comply with the following specifications.

Item	Guide
Reverse voltage	5 to 10 times of the load voltage
Forward current	Load current or more

- External Wiring of Sink Output Type

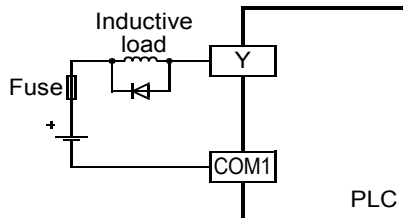

- External Wiring of Source Output Type

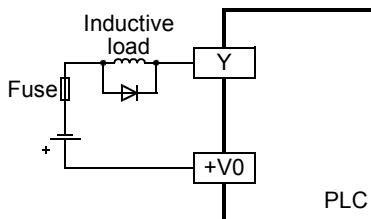

12.3.5 Example of external wiring

1. Transistor output (sink)

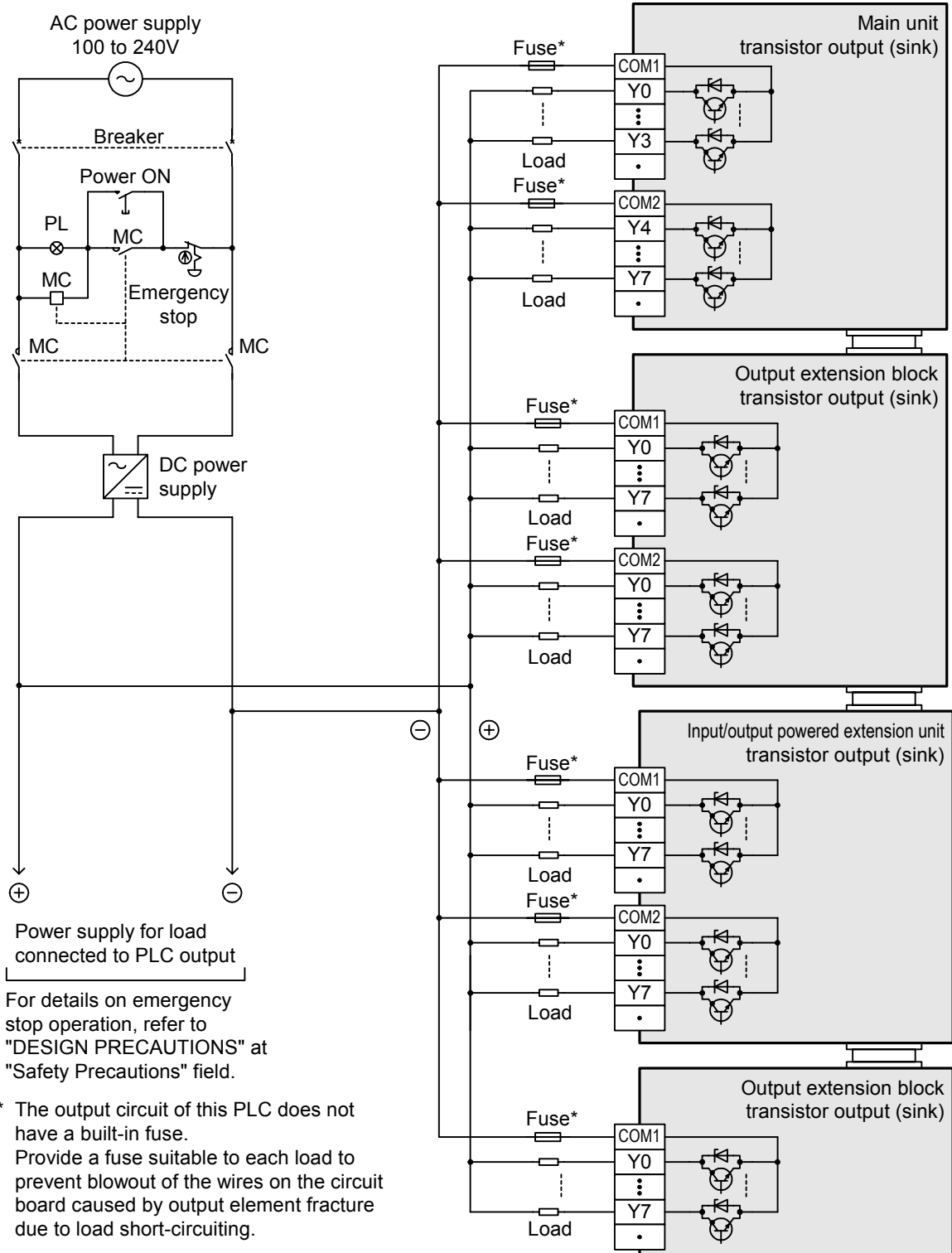

WIRING PRECAUTIONS

CAUTION

- Do not wire vacant terminals externally.
Doing so may damage the product.

11	High-Speed Counters
12	Output Wiring
13	Wiring for Various Uses
14	Test Run, Maintenance, Troubleshooting
15	Input/Output Powered Extension Units
16	Input/Output Extension Blocks
17	Extension Power Supply Unit
18	Other Extension Units and Options
19	Display Module
20	Terminal Block

2. Transistor output (source)

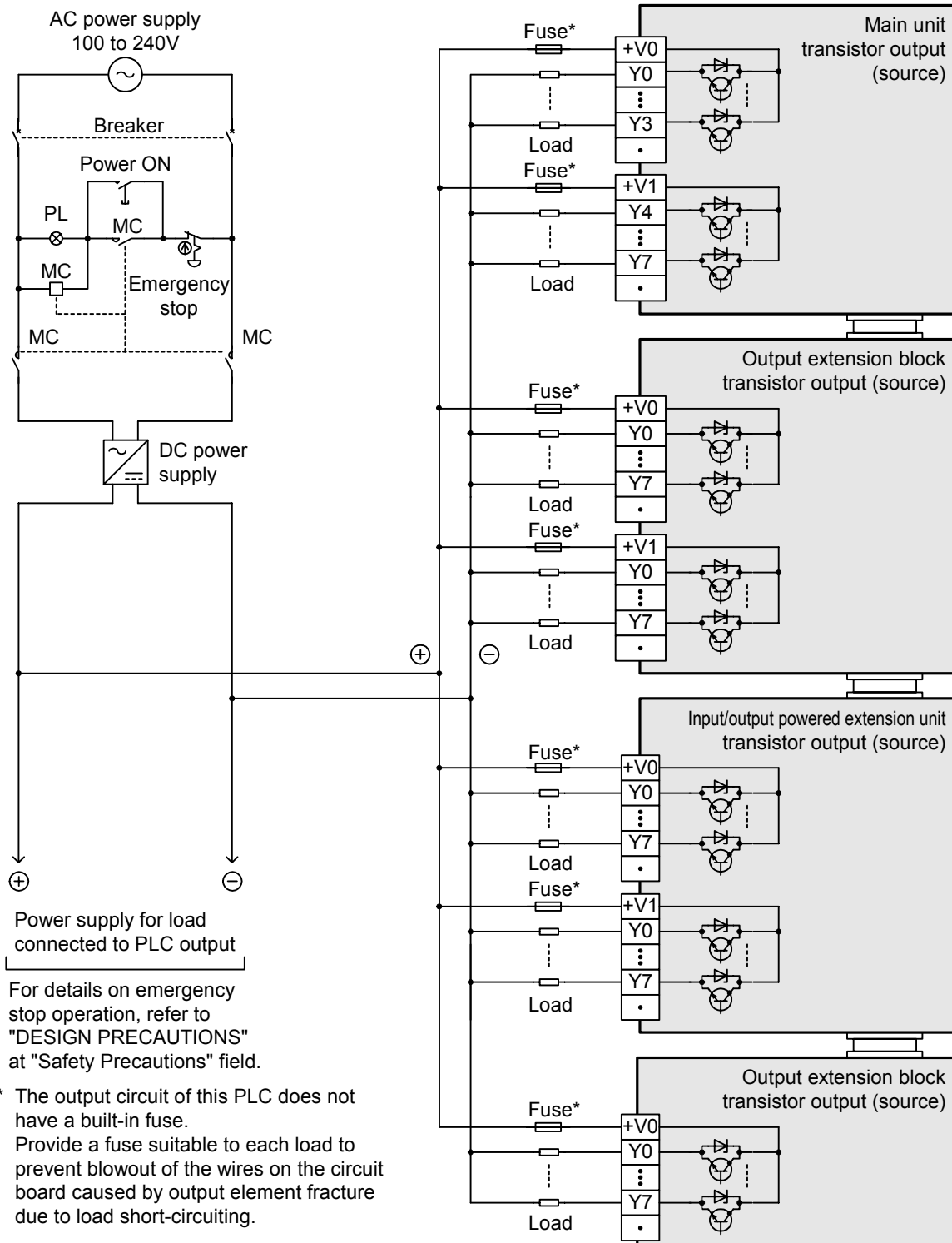

WIRING PRECAUTIONS



- Do not wire vacant terminals externally. Doing so may damage the product.

12.4 External Wiring for Triac (SSR) Output Type

This section explains the triac output specifications (main unit) and external wiring.

- For the main unit, refer to Subsection 12.4.1 "Output specification (main unit) triac output type" and Subsection 12.4.2 "Handling of triac output" and Subsection 12.4.3 "External wiring precautions" and Subsection 12.4.4 "Example of external wiring".
- For the input/output powered extension units/blocks, refer to Subsection 12.4.2 "Handling of triac output" and Subsection 12.4.3 "External wiring precautions". For the specifications and wiring examples, refer to the specifications for each model.
 - For specifications on the input/output powered extension units, refer to Chapter 15.
 - For specifications on the input/output extension blocks, refer to Chapter 16.

12.4.1 Output specification (main unit) triac output type

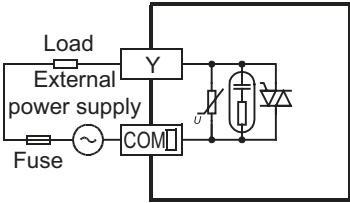
Item		Triac output specifications	
		FX3U-32MS/ES	FX3U-64MS/ES
Number of output points		16 points	32 points
Connecting type		Removable terminal block (M3 screw)	
Output type		Triac output (SSR)	
External power supply		85 to 242V AC	
Max. load	Resistance load	0.3A / point The total load current of resistance loads per common terminal should be the following value. → For details on the common terminal for each model, refer to the terminal block layout. <ul style="list-style-type: none"> • 4 output points/common terminal: 0.8 A or less • 8 output points/common terminal: 0.8 A or less 	
	Inductive load	15 VA/100V AC, 30 VA/200V AC	
Open circuit leakage current		1 mA/100V AC, 2 mA/200V AC	
Min. load		0.4 VA/100V AC, 1.6 VA/200V AC	
Response time	OFF→ON	1 ms or less	
	ON→OFF	10 ms or less	
Circuit insulation		Photo-thyristor insulation	
Display of output operation		LED on panel lights when photo-thyristor is driven.	
Output circuit configuration		 <p>A common number applies to the □ of [COM□].</p>	

11	High-Speed Counters
12	Output Wiring
13	Wiring for Various Uses
14	Test Run, Maintenance, Troubleshooting
15	Input/Output Powered Extension Units
16	Input/Output Extension Blocks
17	Extension Power Supply Unit
18	Other Extension Units and Options
19	Display Module
20	Terminal Block

12.4.2 Handling of triac output

1. Output terminals

On the triac output type units/blocks, one common terminal is used for 4 or 8 points.
Therefore, the common terminal blocks can drive loads of different circuit voltage systems (for example, 100V AC and 200V AC).

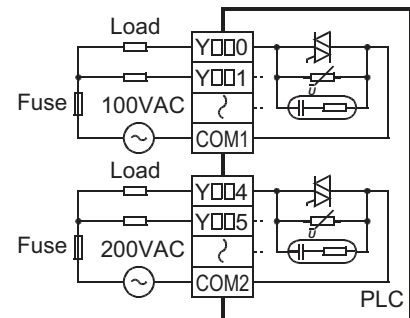

2. Circuit insulation

The PLC internal circuit and the output element (triac) are insulated with a photo-thyristor.
The common terminal blocks are separate from one another.

3. Display of operation

When the photo-thyristor is driven, the LED is lit, and the output triac is turned on.

4. Response time

The time from when the photo-thyristor is driven or shut down until the output triac is turned on and until it is turned off is 1ms or less and 10ms or less, respectively.

5. Output current

The max current per output point is 0.3A. However, to restrict temperature rise, the max current per one output from four points should be 0.8A (average per point is 0.2A).
When a load with high rush current is turned on and off frequently, the root-mean-square current should be 0.2A or less.

<Example>

$$\sqrt{\frac{4^2 \times 0.02 + 0.4^2 \times 0.7}{0.02 + 0.7 + 10}} = 0.2A$$

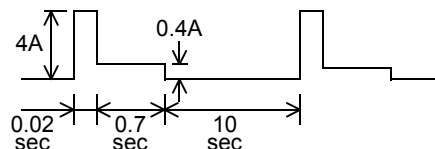

6. Open circuit leakage current

A C-R absorber is connected for turn-off in parallel with the triac output terminal of this type of PLC.
Therefore, when the circuit opens, a leakage current will be 1mA at 100V AC and 2mA at 200V AC.

Since the triac output type devices leak current when the circuits are open, small-size relays and micro current loads having low rated operating current may keep operating even when the triac output is turned off.
Therefore, use a load of 0.4VA or more at 100V AC or 1.6VA or more at 200V AC. If the load is less than this value, connect a surge absorber as stated below in parallel with the load.

→ For the connection of the surge absorber, refer to Subsection 12.4.3 "External wiring precautions".

12.4.3 External wiring precautions

1. Protection circuit for load short-circuits

A short-circuit at a load connected to an output terminal could cause burnout at the output element or the PCB. To prevent this, a protection fuse should be inserted at the output.

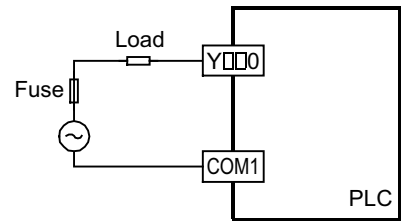

2. Micro current load

The PLC's internal Triac output circuit is equipped with a turn-off C-R absorber. When connecting a very low current load of "0.4VA/100V AC or less, or 1.6VA/200V AC or less", please connect a surge absorber parallel to the load. Select the rated voltage of a surge absorber that is suitable for the load being used. Refer to the table below for other specifications.

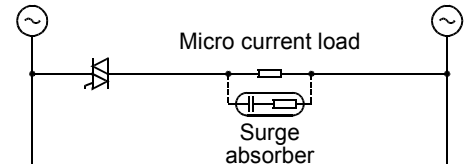

Item	Standard
Static electricity capacity	Approx. 0.1μF
Resistance value	Approx. 100 to 200Ω

Reference

Manufacturer	Model name
Okaya Electric Industries Co., Ltd.	CR-10201

Manufacturer	Model name
Rubycon Corporation	250MCRA104100M B0325

3. Interlock

For loads such as forward/reverse contactors, etc., where a hazardous condition could result if switched ON simultaneously, an external interlock should be provided for interlocking the PLC's internal programs as shown to the right.

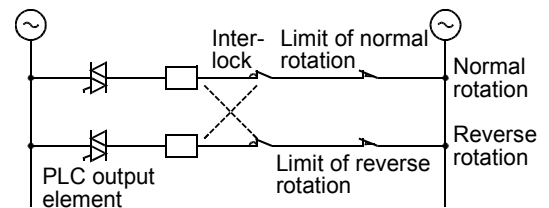

4. In-phase

PLC output contacts (*) should be used in an "in-phase" manner.

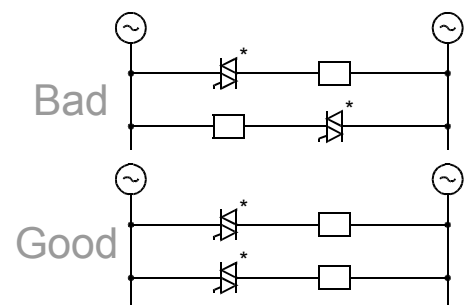

11	High-Speed Counters
12	Output Wiring
13	Wiring for Various Uses
14	Test Run, Maintenance, Troubleshooting
15	Input/Output Powered Extension Units
16	Input/Output Extension Blocks
17	Extension Power Supply Unit
18	Other Extension Units and Options
19	Display Module
20	Terminal Block

12.4.4 Example of external wiring

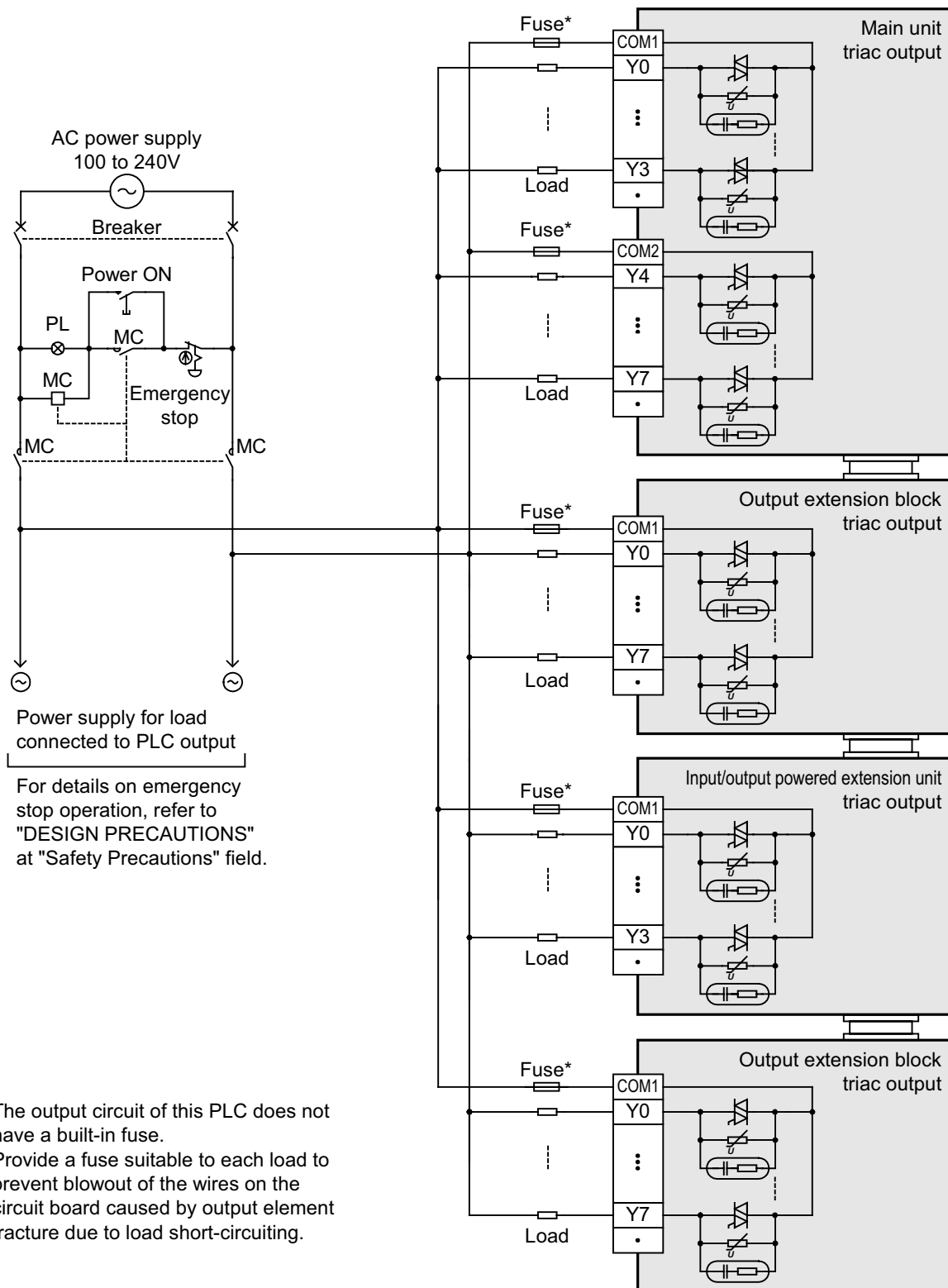

* The output circuit of this PLC does not have a built-in fuse. Provide a fuse suitable to each load to prevent blowout of the wires on the circuit board caused by output element fracture due to load short-circuiting.

WIRING PRECAUTIONS	⚠ CAUTION
<ul style="list-style-type: none"> Do not wire vacant terminals externally. Doing so may damage the product. 	

13. Examples of Wiring for Various Uses

DESIGN PRECAUTIONS



- Make sure to have the following safety circuits outside of the PLC to ensure safe system operation even during external power supply problems or PLC failure. Otherwise, malfunctions may cause serious accidents.
 - 1) Most importantly, have the following: an emergency stop circuit, a protection circuit, an interlock circuit for opposite movements (such as normal vs. reverse rotation), and an interlock circuit (to prevent damage to the equipment at the upper and lower positioning limits).
 - 2) Note that when the PLC CPU detects an error, such as a watchdog timer error, during self-diagnosis, all outputs are turned off. Also, when an error that cannot be detected by the PLC CPU occurs in an input/output control block, output control may be disabled. External circuits and mechanisms should be designed to ensure safe machinery operation in such a case.
 - 3) Note that the output current of the 24V DC service power supply varies depending on the model and the absence/presence of extension blocks. If an overload occurs, the voltage automatically drops, inputs in the PLC are disabled, and all outputs are turned off. External circuits and mechanisms should be designed to ensure safe machinery operation in such a case.
 - 4) Note that when an error occurs in a relay, triac or transistor output device, the output could be held either on or off. For output signals that may lead to serious accidents, external circuits and mechanisms should be designed to ensure safe machinery operation in such a case.

DESIGN PRECAUTIONS



- Do not bundle the control line together with or lay it close to the main circuit or power line. As a guideline, lay the control line at least 100mm (3.94") or more away from the main circuit or power line. Noise may cause malfunctions.
- Install module so that excessive force will not be applied to peripheral device connectors. Failure to do so may result in wire damage/breakage or PLC failure.

WIRING PRECAUTIONS



- Make sure to cut off all phases of the power supply externally before attempting installation or wiring work. Failure to do so may cause electric shock or damage to the product.
- Make sure to attach the terminal cover, offered as an accessory, before turning on the power or initiating operation after installation or wiring work. Failure to do so may cause electric shock.

11

High-Speed
Counters

12

Output Wiring

13

Wiring for
Various Uses

14

Test Run,
Maintenance,
Troubleshooting

15

Input/Output
Powered
Extension Units

16

Input/Output
Extension
Blocks

17

Extension
Power Supply
Unit

18

Other Extension
Units and
Options

19

Display Module

20

Terminal Block

WIRING PRECAUTIONS



- Do not supply power to the [24+] and [24V] terminals (24V DC service power supply) on the main unit or extension units.
Doing so may cause damage to the product.
- Perform class D grounding (grounding resistance: 100 Ω or less) to the grounding terminal on the main unit and extension units with a wire 2 mm² or thicker.
Do not use common grounding with heavy electrical systems (refer to Section 9.4).
- Connect the AC power supply wiring to the dedicated terminals described in this manual.
If an AC power supply is connected to a DC input/output terminal or DC power supply terminal, the PLC will burn out.
- Connect the DC power supply wiring to the dedicated terminals described in this manual.
If an AC power supply is connected to a DC input/output terminal or DC power supply terminal, the PLC will burn out.
- Do not wire vacant terminals externally.
Doing so may damage the product.
- When drilling screw holes or wiring, make sure that cutting and wiring debris do not enter the ventilation slits.
Failure to do so may cause fire, equipment failures or malfunctions.
- Make sure to properly wire the FX3U Series main unit and FX0N/FX2N/FX3U Series extension equipment in accordance with the following precautions.
Failure to do so may cause electric shock, equipment failures, a short-circuit, wire breakage, malfunctions, or damage to the product.
 - The disposal size of the cable end should follow the dimensions described in the manual.
 - Tightening torque should follow the specifications in the manual.
- Make sure to properly wire to the terminal block (European type) in accordance with the following precautions.
Failure to do so may cause electric shock, equipment failures, a short-circuit, wire breakage, malfunctions, or damage to the product.
 - The disposal size of the cable end should follow the dimensions described in the manual.
 - Tightening torque should follow the specifications in the manual.
 - Twist the end of strand wire and make sure that there are no loose wires.
 - Do not solder-plate the electric wire ends.
 - Do not connect more than the specified number of wires or electric wires of unspecified size.
 - Affix the electric wires so that neither the terminal block nor the connected parts are directly stressed.
- Make sure to properly wire to the FX Series terminal blocks in accordance with the following precautions.
Failure to do so may cause electric shock, equipment failures, a short-circuit, wire breakage, malfunctions, or damage to the product.
 - The disposal size of the cable end should follow the dimensions described in the manual.
 - Tightening torque should follow the specifications in the manual.

13.1 Notes about Examples of Wiring

The examples of wiring are given under the following conditions.

- The input/output numbers are the actual numbers on the program. (They may differ from the numbers shown on the product terminals.)
- Product input/output specifications
Check the product input/output specifications when using any example of wiring.
 - Products only for sink input and products both for sink input and for source input are available.
 - Products for sink output and products for source output are available.
- The examples of programming (applied instructions) are given based on the allocation of the input/output numbers for wiring.

→ For the applied instructions, refer to the Programming Manual.

13.2 Digital Switch [DSW Instruction (FNC 72)/BIN Instruction (FNC 19)]

13.2.1 When DSW instructions are used

Examples of wiring for capturing values from a 4-digit digital switch to the data register D100 are given below.

1. Main unit

Example of program

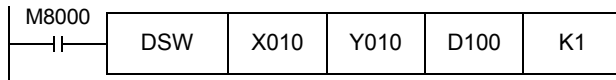

Example of wiring

In case of sink wiring

When inputs are used for both sink and source and outputs are the transistor sink type in the used main unit

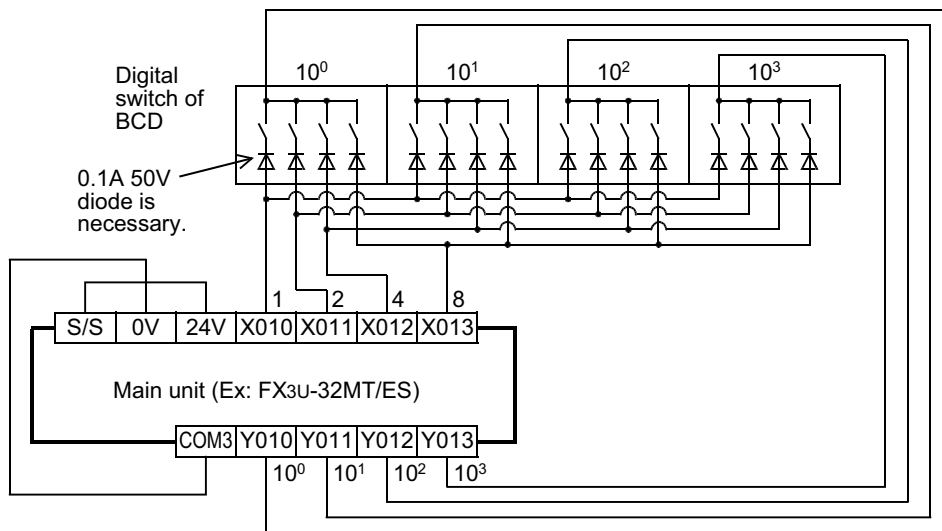

In case of source wiring

When inputs are used for both sink and source and outputs are the transistor source type in the used main unit

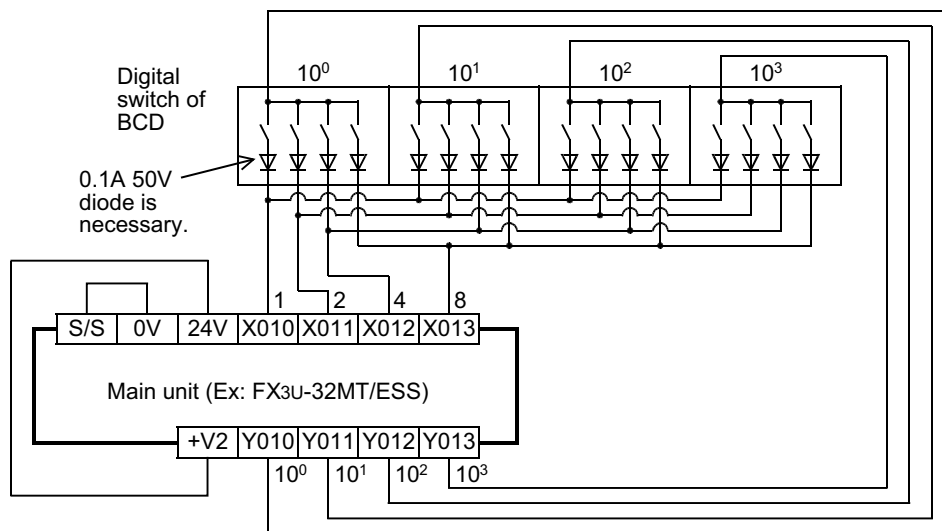

2. Main unit + input/output powered extension unit/block

Example of program

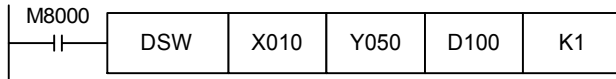

Examples of wiring

In case of sink wiring

When the main unit and a transistor output (sink) type input/output powered extension unit/block are used

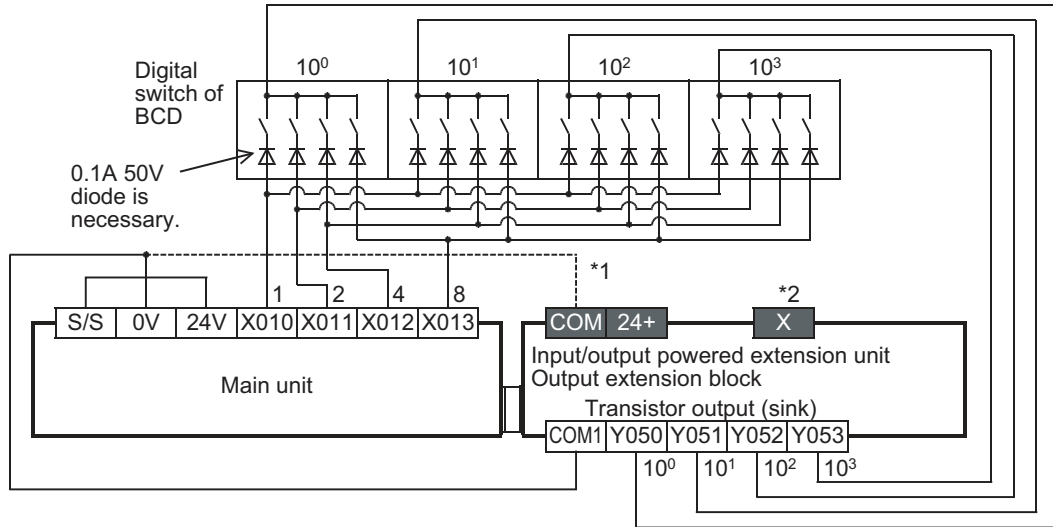

*1 To use the input terminal (X) of the input/output powered extension unit, wire the terminal as shown by the dotted line

*2 The terminals in the shaded areas are provided on input/output powered extension units (ex.: FX2N-32ET).
Output extension blocks do not have the terminals.

In case of source wiring

When the main unit and a transistor output (source) type input/output powered extension unit/block are used

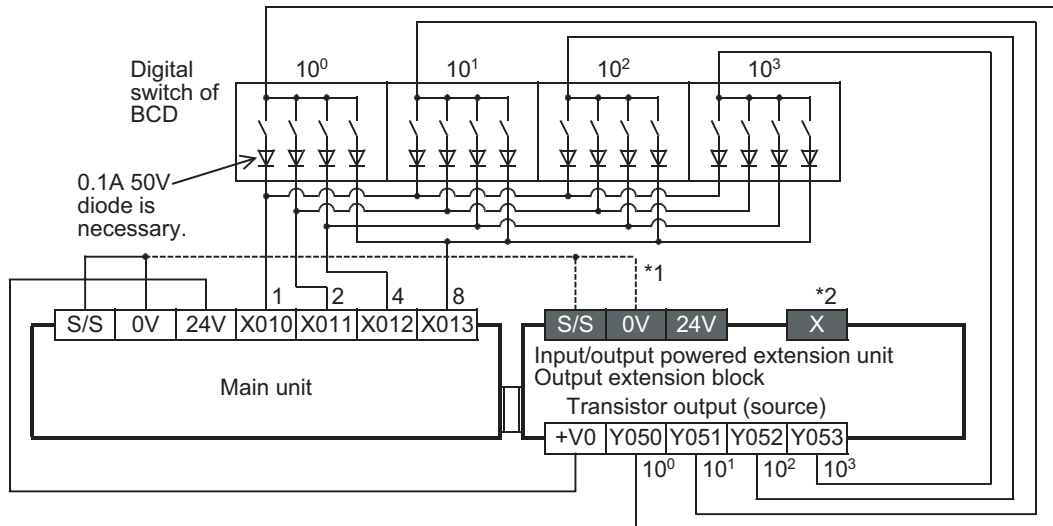

*1 To use the input terminal (X) of the input/output powered extension unit, wire the terminal as shown by the dotted line

*2 The terminals in the shaded areas are provided on input/output powered extension units (ex.: FX2N-32ET-ESS/UL).
Output extension blocks do not have the terminals.

3. Input/output powered extension unit

Example of program

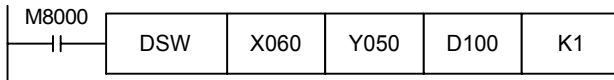

Examples of wiring

In case of sink wiring

When inputs are used for sink only and outputs are the transistor sink type in the used input/output powered extension unit

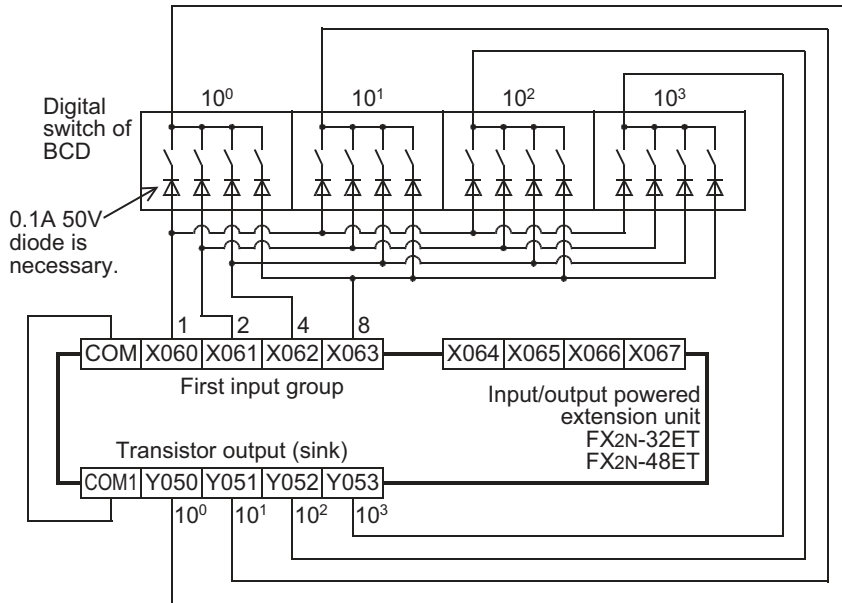

In case of source wiring

When inputs are used for both sink and source and outputs are the transistor source type in the used input/output powered extension unit

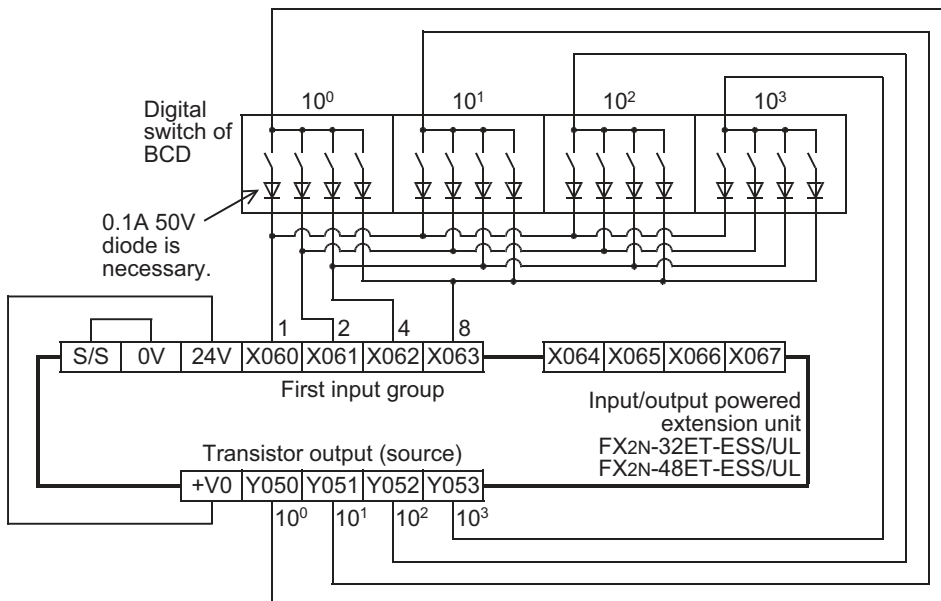

11	High-Speed Counters
12	Output Wiring
13	Wiring for Various Uses
14	Test Run, Maintenance, Troubleshooting
15	Input/Output Powered Extension Units
16	Input/Output Extension Blocks
17	Extension Power Supply Unit
18	Other Extension Units and Options
19	Display Module
20	Terminal Block

13.2.2 When BIN instructions are used

Examples of wiring for capturing values from a 2-digit digital switch to the data register D102 are given below.

Example of program

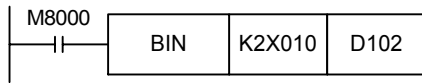

Examples of wiring

In case of sink wiring

When a sink and source input type unit is used

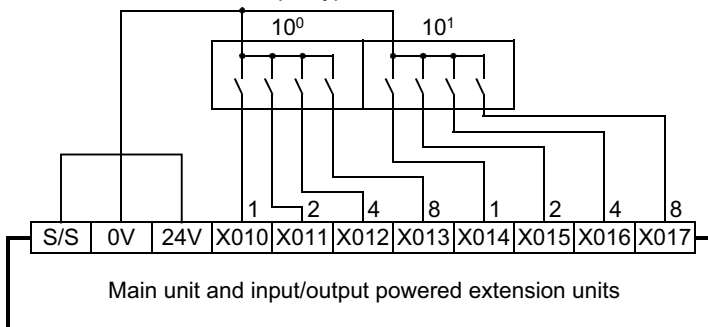

When a sink input type unit is used

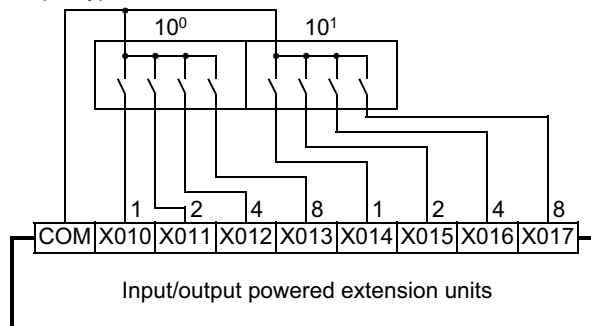

In case of source wiring

When a sink and source input type unit is used

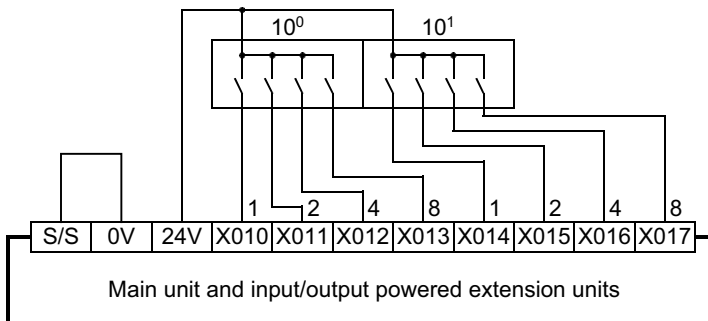

13.3 Ten Key Input [TKY Instruction (FNC 70)]

This section gives examples of wiring for capturing values from ten-key pad to D100 using TKY instructions.

Example of program

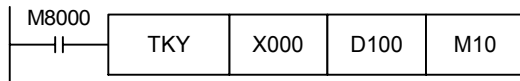

Examples of wiring

In case of sink wiring

When a sink and source input type unit is used

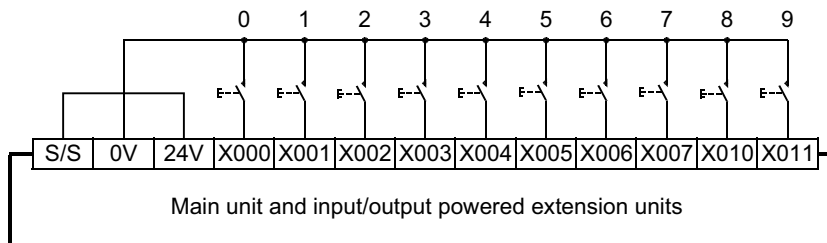

When a sink input type unit is used

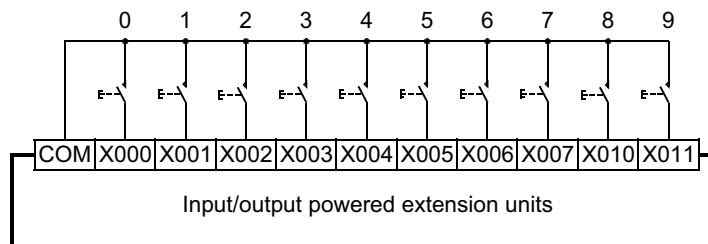

In case of source wiring

When a sink and source input type unit is used

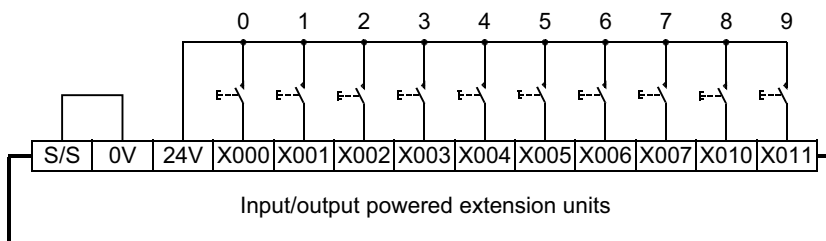

11	High-Speed Counters
12	Output Wiring
13	Wiring for Various Uses
14	Test Run, Maintenance, Troubleshooting
15	Input/Output Powered Extension Units
16	Input/Output Extension Blocks
17	Extension Power Supply Unit
18	Other Extension Units and Options
19	Display Module
20	Terminal Block

13.4 Hexadecimal Input [HKY Instruction (FNC 71)]

This section gives examples of wiring for capturing values (0 to 9) and function keys (A to F) from 16 switches (16 keys) to D100 and M0 to M5 using HKY instructions. (Hexadecimal values can be captured.)

1. Main Unit

Example of program

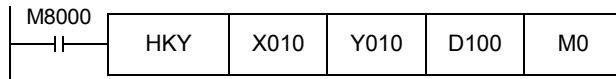

Example of wiring

In case of sink wiring

When inputs are used for both sink and source and outputs are the transistor output (sink) type in the used main unit

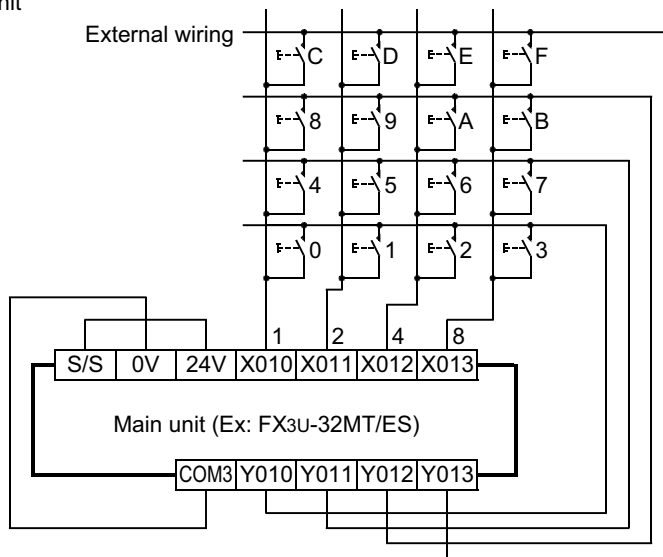

In case of source wiring

When inputs are used for both sink and source and outputs are the transistor output (source) type in the used main unit

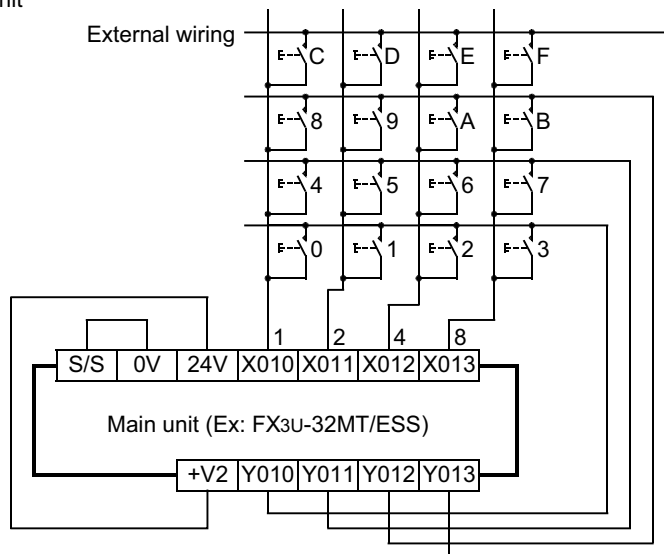

2. Main unit + input/output powered extension unit/block

Example of program

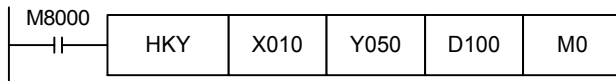

Examples of wiring

In case of sink wiring

When the main unit and a transistor output (sink) type input/output powered extension unit/block are used

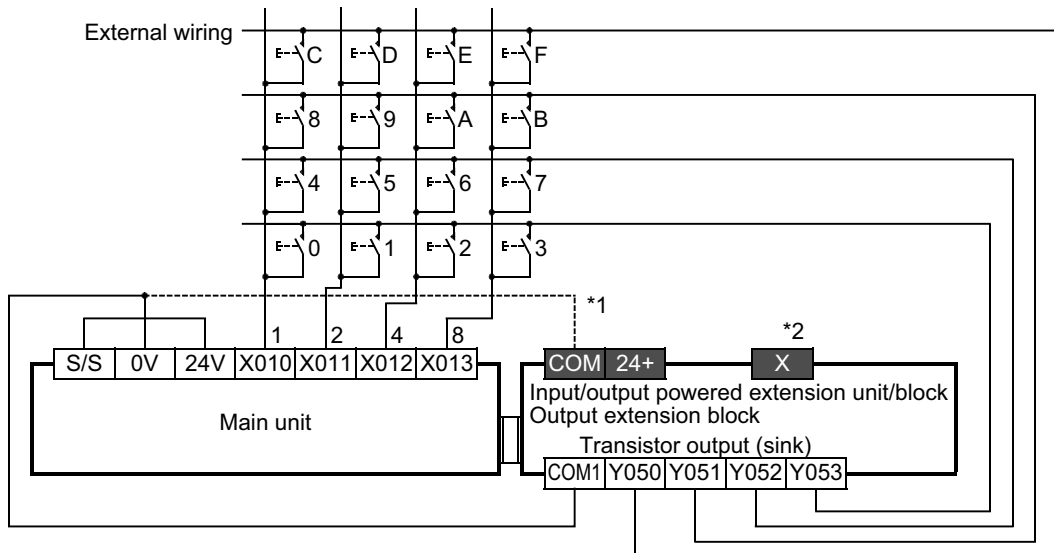

*1 To use the input terminal (X) of the input/output powered extension unit, wire the terminal as shown by the dotted line

*2 The terminals in the shaded areas are provided on input/output powered extension units (ex.: FX2N-32ET).
Output extension blocks do not have the terminals.

In case of source wiring

When the main unit and a transistor output (source) type input/output powered extension unit/block are used

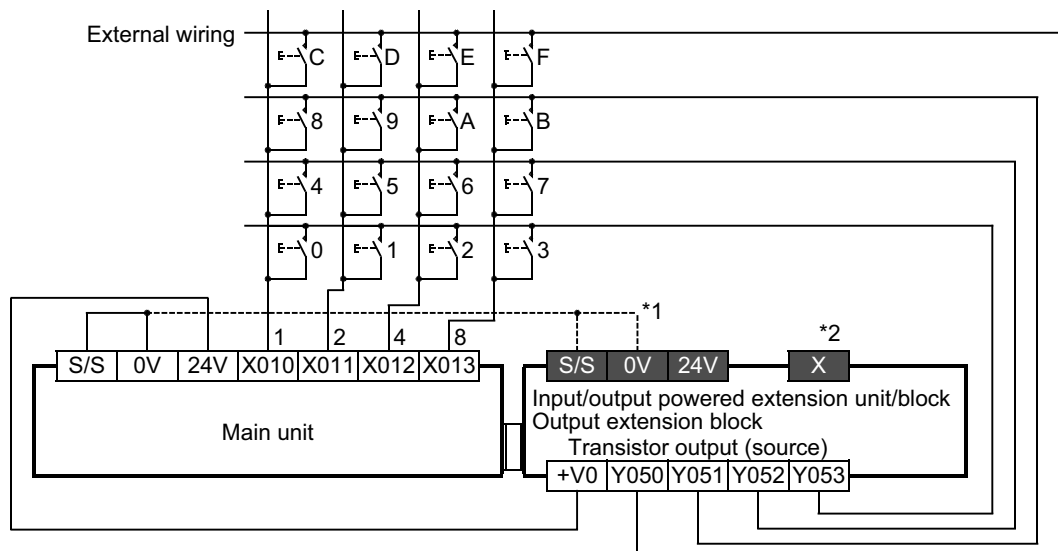

*1 To use the input terminal (X) of the input/output powered extension unit, wire the terminal as shown by the dotted line

*2 The terminals in the shaded areas are provided on input/output powered extension units (ex.: FX2N-32ET-ESS/UL).
Output extension blocks do not have the terminals.

11	High-Speed Counters
12	Output Wiring
13	Wiring for Various Uses
14	Test Run, Maintenance, Troubleshooting
15	Input/Output Powered Extension Units
16	Input/Output Extension Blocks
17	Extension Power Supply Unit
18	Other Extension Units and Options
19	Display Module
20	Terminal Block

3. Input/output powered extension unit

Example of program

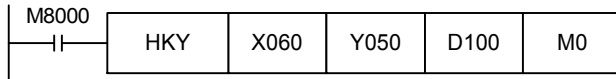

Examples of wiring

In case of sink wiring

When inputs are used for sink only and outputs are the transistor sink type in the used input/output powered extension unit

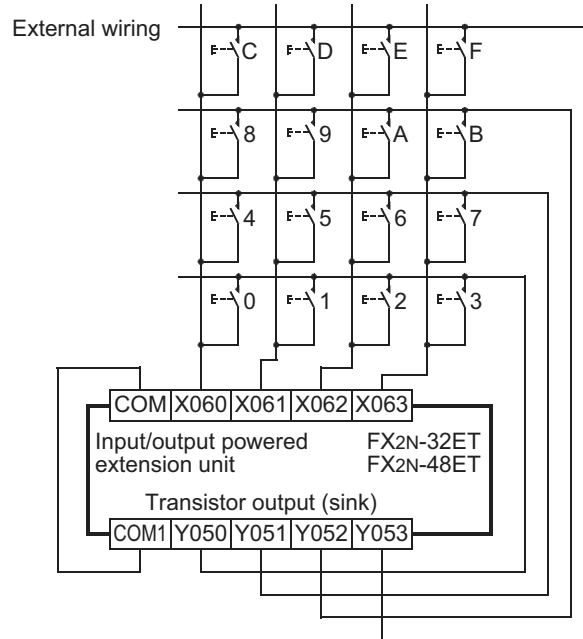

In case of source wiring

When inputs are used for both sink and source and outputs are the transistor source type in the used input/output powered extension unit

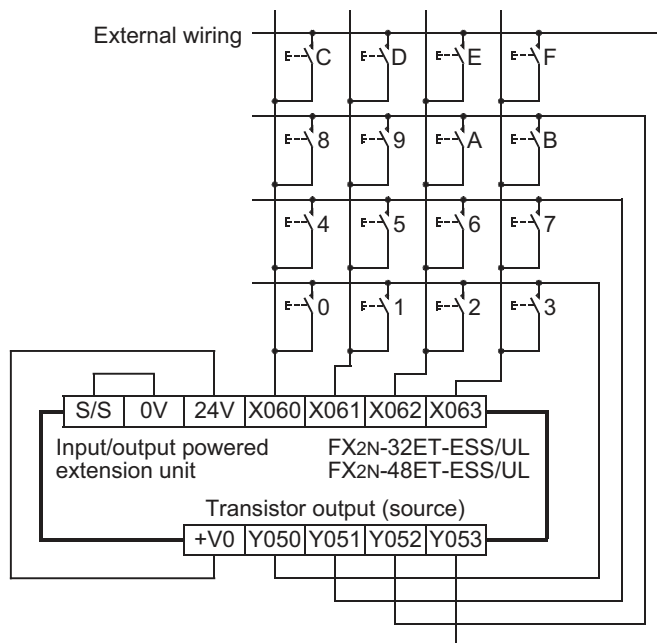

13.5 Input Matrix [MTR Instruction (FNC 52)]

This section gives examples of wiring for capturing the ON/OFF status of 24 switches to M30 to M37, M40 to M47 and M50 to M57 using MTR instructions.

1. Main Unit

Example of program

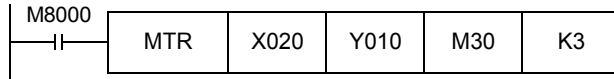

Example of wiring

In case of sink wiring

When inputs are used for both sink and source and outputs are the transistor sink type in the used main unit

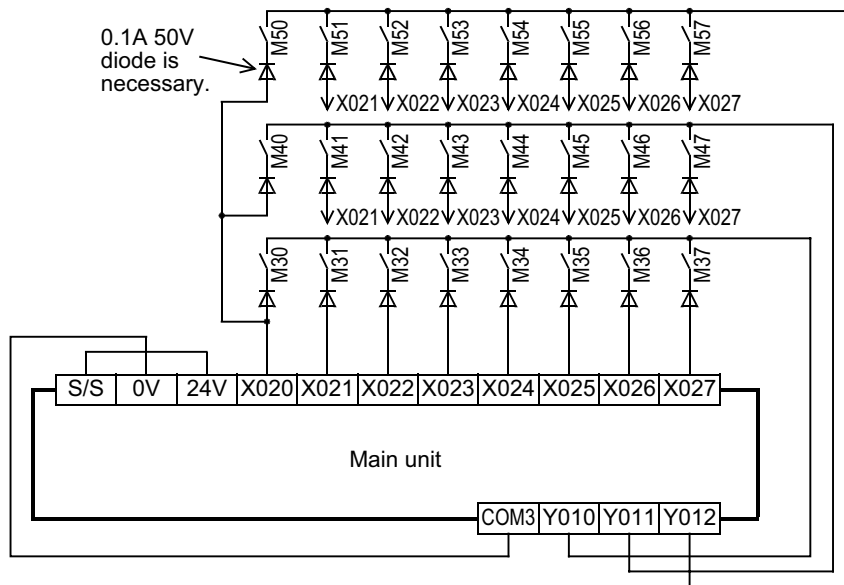

In case of source wiring

When inputs are used for both sink and source and outputs are the transistor source type in the used main unit

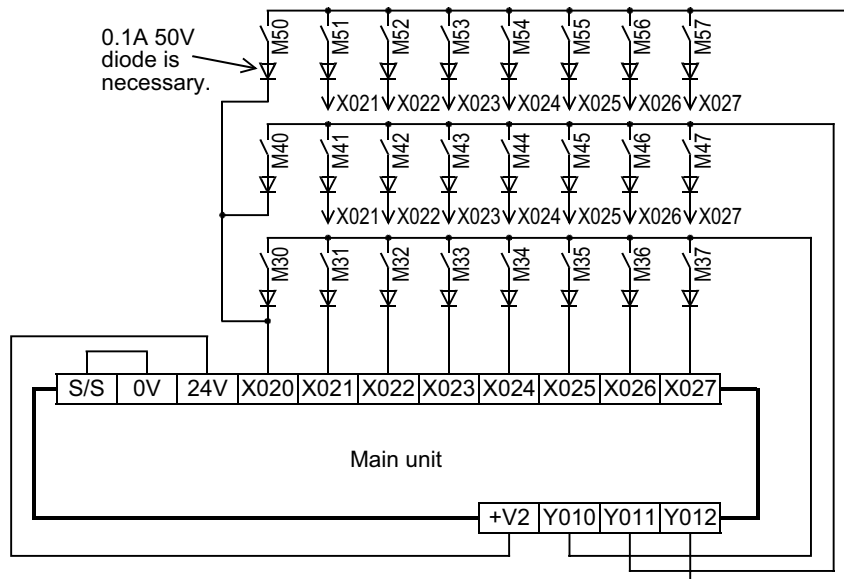

11	High-Speed Counters
12	Output Wiring
13	Wiring for Various Uses
14	Test Run, Maintenance, Troubleshooting
15	Input/Output Powered Extension Units
16	Input/Output Blocks
17	Extension Power Supply Unit
18	Other Extension Units and Options
19	Display Module
20	Terminal Block

2. Main unit + input/output powered extension unit/block

Example of program

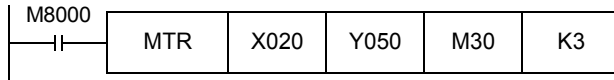

Examples of wiring

In case of sink wiring

When the main unit and a transistor output (sink) type input/output powered extension unit/block are used

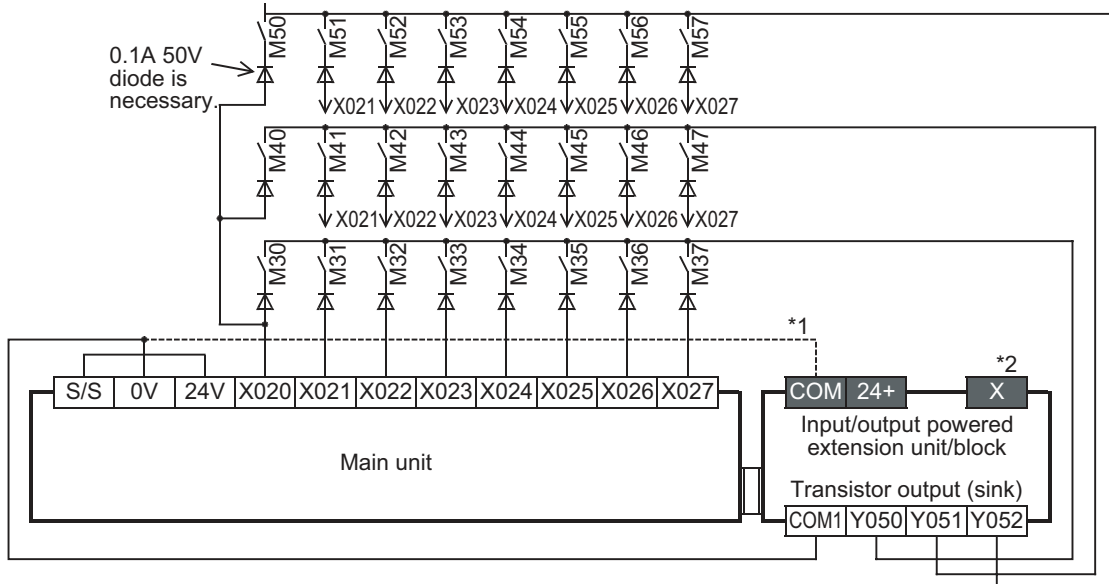

- *1 To use the input terminal (X) of the input/output powered extension unit, wire the terminal as shown by the dotted line
- *2 The terminals in the shaded areas are provided on input/output powered extension units (ex.: FX2N-32ET). Output extension blocks do not have the terminals.

In case of source wiring

When the main unit and a transistor output (source) type input/output powered extension unit/block are used

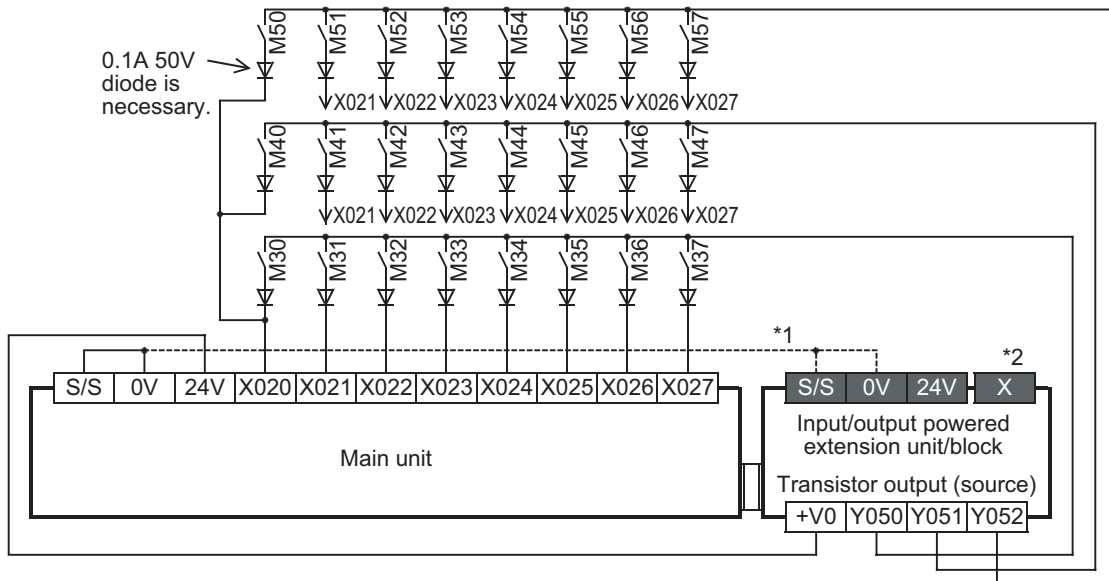

- *1 To use the input terminal (X) of the input/output powered extension unit, wire the terminal as shown by the dotted line
- *2 The terminals in the shaded areas are provided on input/output powered extension units (ex.: FX2N-32ET-ESS/UL). Output extension blocks do not have the terminals.

3. Input/output powered extension unit

Example of program

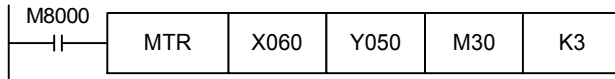

Examples of wiring

In case of sink wiring

When inputs are used for sink only and outputs are the transistor sink type in the used input/output powered extension unit

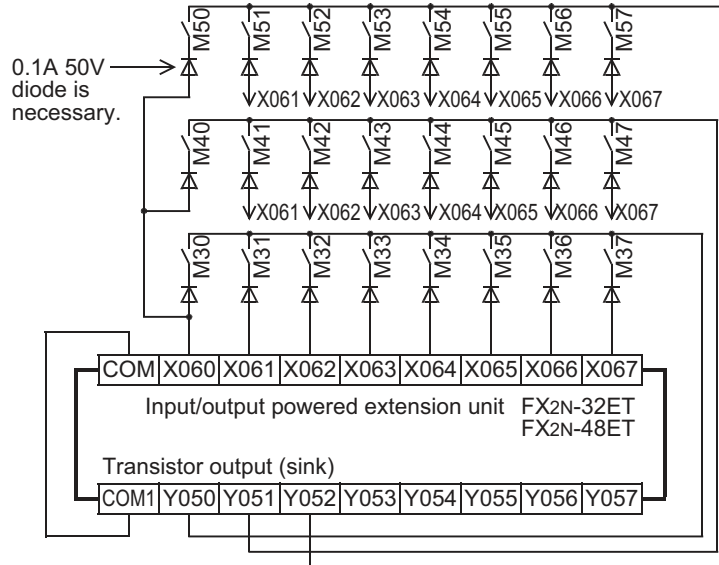

In case of source wiring

When inputs are used for both sink and source and outputs are the transistor source type in the used input/output powered extension unit

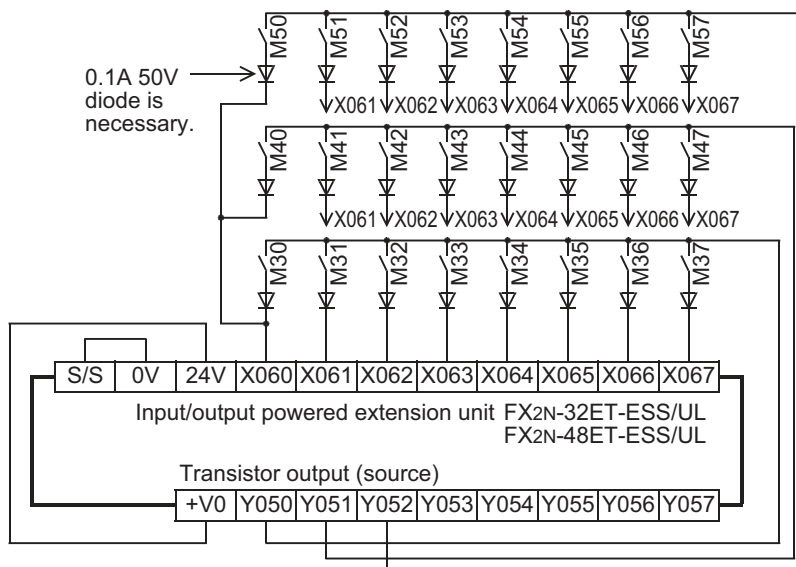

11	High-Speed Counters
12	Output Wiring
13	Wiring for Various Uses
14	Test Run, Maintenance, Troubleshooting
15	Input/Output Powered Extension Units
16	Input/Output Extension Blocks
17	Extension Power Supply Unit
18	Other Extension Units and Options
19	Display Module
20	Terminal Block

13.6 Seven Segment with Latch [SEGL Instruction (FNC 74)/BCD Instruction (FNC 18)]

13.6.1 When SEGL instructions are used

This subsection gives examples of wiring for displaying the current value of D100 on the 4-digit 7-segment display.

1. Main Unit

Example of program

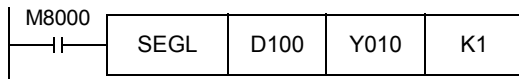

Example of wiring

In case of sink wiring

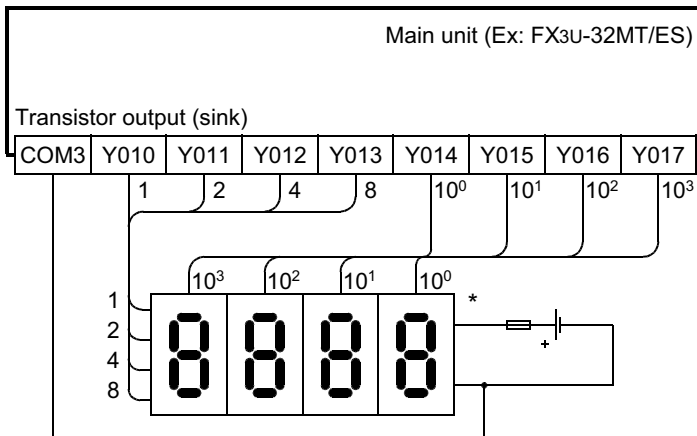

* Use a 7-segment display with a latch and a built-in BCD decoder.

7-segment display to be used for sink wiring (in case of transistor output)

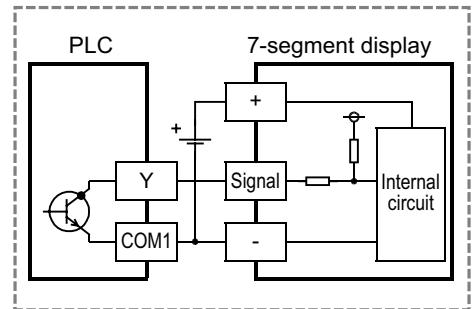

In case of source wiring

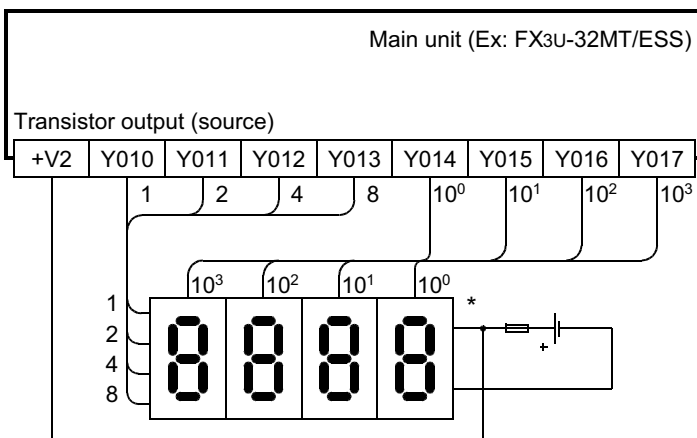

* Use a 7-segment display with a latch and a built-in BCD decoder.

7-segment display to be used for source wiring (in case of transistor output)

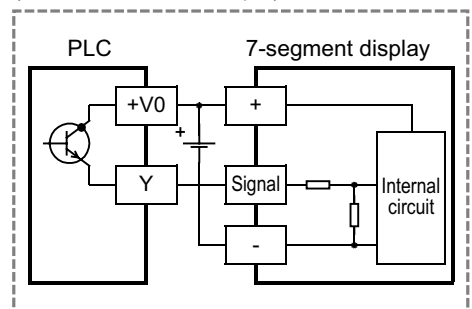

2. Input/output powered extension unit

Example of program

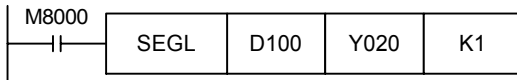

Examples of wiring

In case of sink wiring

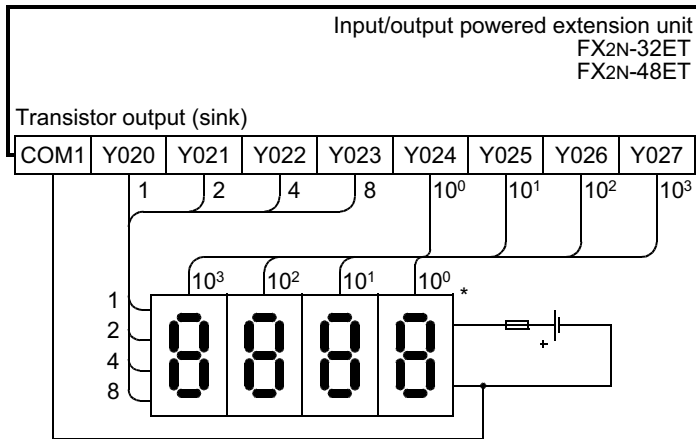

* Use a 7-segment display with a latch and a built-in BCD decoder.

In case of source wiring

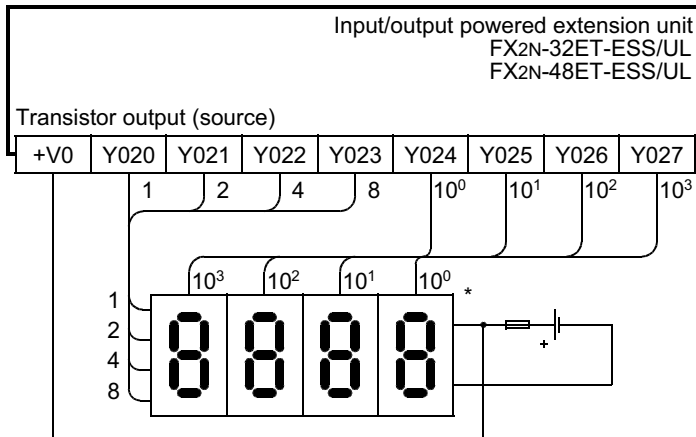

* Use a 7-segment display with a latch and a built-in BCD decoder.

7-segment display to be used for sink wiring (in case of transistor output)

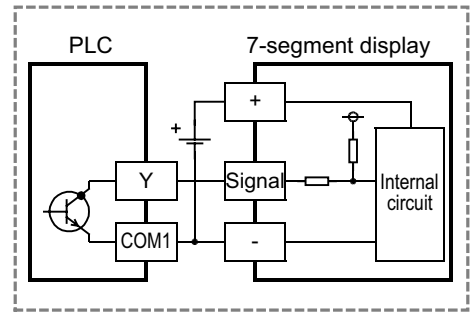

7-segment display to be used for source wiring (in case of transistor output)

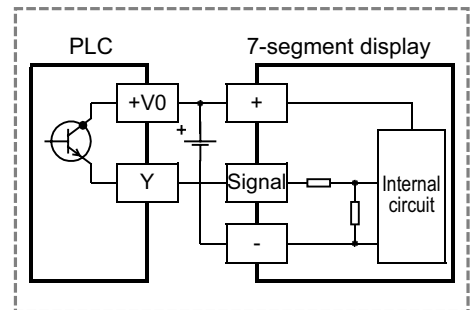

11	High-Speed Counters
12	Output Wiring
13	Wiring for Various Uses
14	Test Run, Maintenance, Troubleshooting
15	Input/Output Powered Extension Units
16	Input/Output Extension Blocks
17	Extension Power Supply Unit
18	Other Extension Units and Options
19	Display Module
20	Terminal Block

13.6.2 When BCD instructions are used

This subsection gives examples of wiring for displaying the current value of D100 on the 2-digit 7-segment display.

1. Main Unit

Example of program

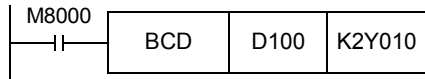

Example of wiring

In case of sink wiring

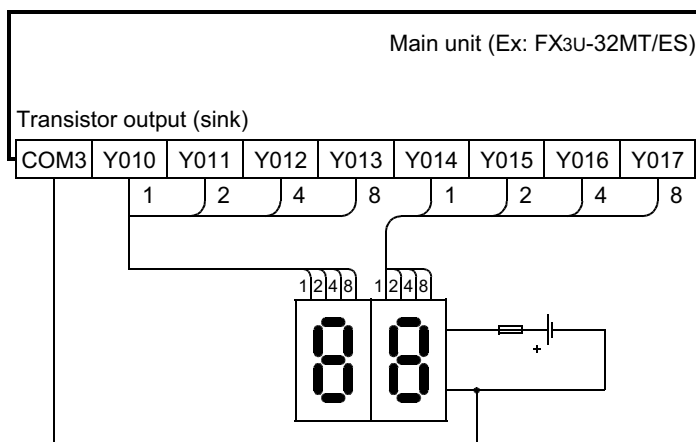

7-segment display to be used for sink wiring (in case of transistor output)

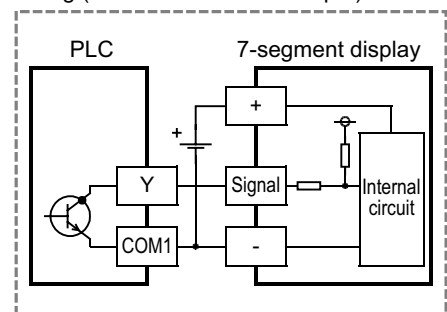

In case of source wiring

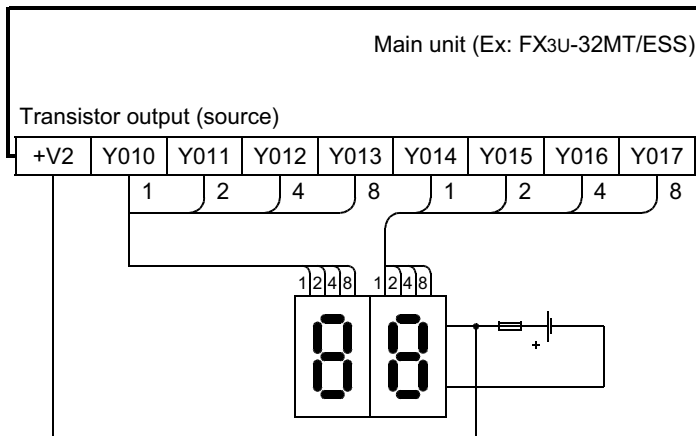

7-segment display to be used for source wiring (in case of transistor output)

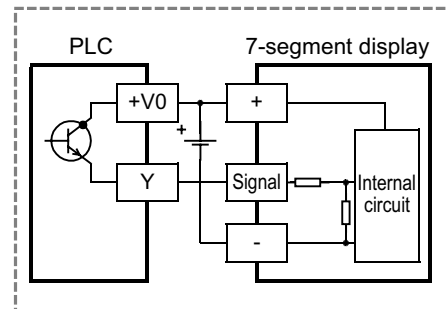

2. Input/output powered extension units

Example of program

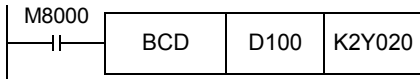

Examples of wiring

In case of sink wiring

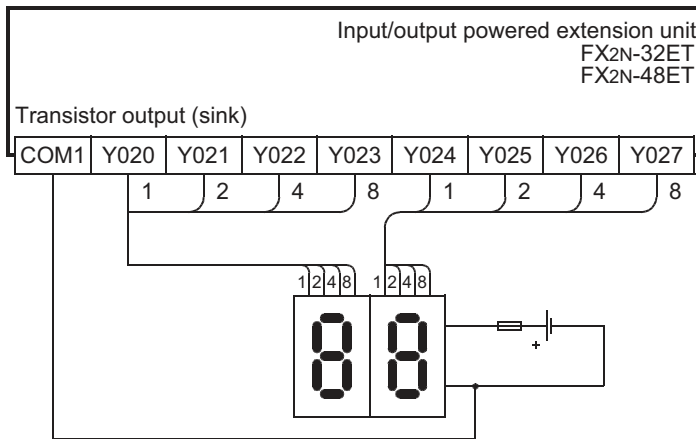

7-segment display to be used for sink wiring (in case of transistor output)

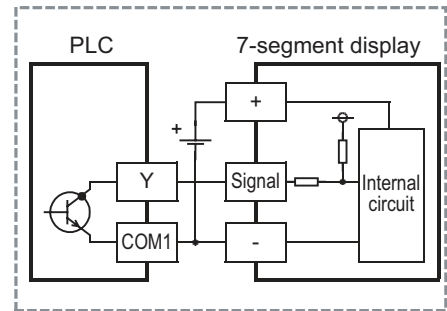

In case of source wiring

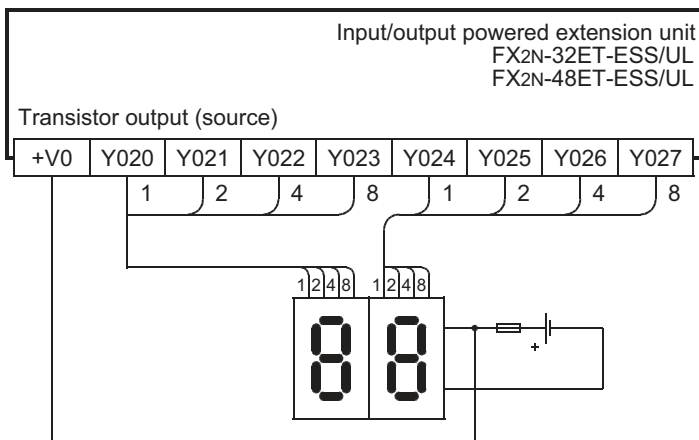

7-segment display to be used for source wiring (in case of transistor output)

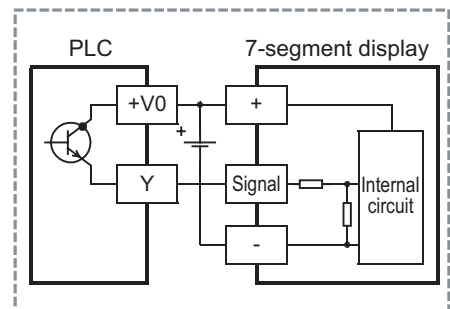

11	High-Speed Counters
12	Output Wiring
13	Wiring for Various Uses
14	Test Run, Maintenance, Troubleshooting
15	Input/Output Powered Extension Units
16	Input/Output Extension Blocks
17	Extension Power Supply Unit
18	Other Extension Units and Options
19	Display Module
20	Terminal Block

14. Test Operation, Adjustment, Maintenance and Troubleshooting

STARTUP AND MAINTENANCE PRECAUTIONS



DANGER

- Do not touch any terminal while the PLC's power is on.
Doing so may cause electric shock or malfunctions.
- Before cleaning or retightening terminals, cut off all phases of the power supply externally.
Failure to do so may cause electric shock.
- Use the battery for memory backup correctly in conformance to this manual.
 - Use the battery only for the specified purpose.
 - Connect the battery correctly.
 - Do not charge, disassemble, heat, put in fire, short-circuit, connect reversely, weld, swallow or burn the battery, or apply excessive forces (vibration, impact, drop, etc.) to the battery.
 - Do not store or use the battery at high temperatures or expose to direct sunlight.
 - Do not expose to water, bring near fire or touch liquid leakage or other contents directly.
 - Incorrect handling of the battery may cause heat excessive generation, bursting, ignition, liquid leakage or deformation, and lead to injury, fire or failures and malfunctions of facilities and other equipment.
- Before modifying or disrupting the program in operation or running the PLC, carefully read through this manual and the associated manuals and ensure the safety of the operation.
An operation error may damage the machinery or cause accidents.
- Do not change the program in the PLC from two or more peripheral equipment devices at the same time. (i.e. from a programming tool and a GOT)
Doing so may cause destruction or malfunction of the PLC program.

STARTUP AND MAINTENANCE PRECAUTIONS



CAUTION

- Turn off the power to the PLC before attaching or detaching the memory cassette. If the memory cassette is attached or detached while the PLC's power is on, the data in the memory may be destroyed, or the memory cassette may be damaged.
- Do not disassemble or modify the PLC.
Doing so may cause fire, equipment failures, or malfunctions.
For repair, contact your local Mitsubishi Electric representative.
- Turn off the power to the PLC before connecting or disconnecting any extension cable.
Failure to do so may cause equipment failures or malfunctions.
- Turn off the power to the PLC before attaching or detaching the following devices.
Failure to do so may cause equipment failures or malfunctions.
 - Peripheral devices, display module, expansion boards, and special adapters
 - Extension units/blocks and FX Series terminal blocks
 - Battery and memory cassette

DISPOSAL PRECAUTIONS



CAUTION

- Please contact a certified electronic waste disposal company for the environmentally safe recycling and disposal of your device.
When disposing of batteries, separate them from other waste according to local regulations.
(For details of the Battery Directive in EU countries, refer to Appendix F)

TRANSPORTATION AND STORAGE PRECAUTIONS



- Before transporting the PLC, turn on the power to the PLC to check that the BATT LED is off. If the PLC is transported with the BATT LED on or the battery exhausted, the battery-backed data may be unstable during transportation.
- The PLC is a precision instrument. During transportation, avoid impacts larger than those specified in the general specifications (section 4.1). Failure to do so may cause failures in the PLC. After transportation, verify the operations of the PLC.
- When transporting lithium batteries, follow required transportation regulations. (For details of the regulated products, refer to Appendix E)

14.1 Preparation for Test Operation

14.1.1 Preliminary inspection [power OFF]

Incorrect connection of the power supply terminal, contact of the DC input wire and power supply wire, or short-circuiting of output wires may result in serious damage. Before applying power, check that the power supply and ground terminals are connected correctly and input/output devices are wired properly.

Notes

- The dielectric withstand voltage and insulation resistance test of the PLC should be measured in accordance with the following procedures.
- 1) Remove all input/output wires and power supply wires from the PLC.
 - 2) Connect a crossing wire to each of the PLC terminals (power supply terminal, input terminals and output terminals) except the ground terminal.
For the dielectric withstand voltage test of each terminal, refer to the generic specifications for the product.
→ **Refer to Section 4.1.**
 - 3) Measure the dielectric withstand voltage and insulation resistance between each terminal and the ground terminal.
Dielectric withstand voltage: 1.5kV AC or 500V for 1min (The terminals vary in dielectric withstand voltage.)
Insulation resistance: 500V DC / 5MΩ or more

14.1.2 Connection to built-in programming connector

When connecting the communication cable of a peripheral device, align the positioning mark of the cable with that of the main unit.

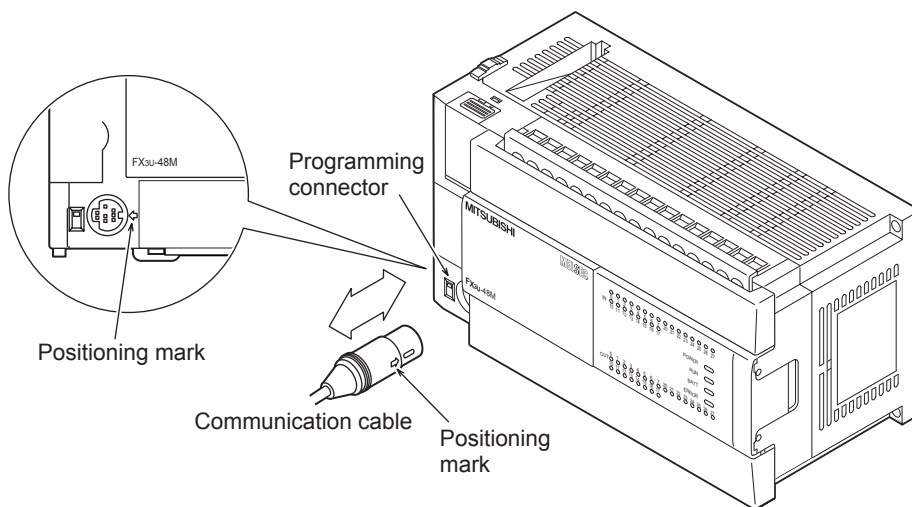

11 High-Speed Counters
12 Output Wiring
13 Wiring for Various Uses
14 Test Run, Maintenance, Troubleshooting
15 Input/Output Powered Extension Units
16 Input/Output Extension Blocks
17 Extension Power Supply Unit
18 Other Extension Units and Options
19 Display Module
20 Terminal Block

14.1.3 Writing of program and program check [power ON and PLC stopped]

1 Turn on the PLC power.

Make sure that the RUN/STOP switch of the PLC is set to STOP, and turn the power on.

2 Check the program.

Check for circuit errors and grammatical errors with the program check function of the programming tool.

3 Transfer the sequence program.

Write the program to the memory cassette with the programming tool.

When the memory cassette is used

Make sure to set the PROTECT switch of the memory cassette to OFF (shown right).

→ For details on handling of the memory cassette, refer to Chapter 21.

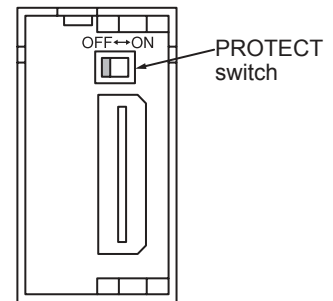

4 Verify the sequence program.

Verify that the program has been correctly written to the memory cassette.

5 Execute PLC diagnosis.

Check for errors in the PLC main body with the PLC diagnostic function of the programming tool.

→ For details on the PLC diagnosis with the display module or GX Developer, refer to Section 14.6.

14.2 Running and Stopping Procedures [Power ON]

14.2.1 Methods of running and stopping

FX3U PLCs can be started or stopped by any of the following three methods. Two of the methods can be combined.

1. Operation with built-in RUN/STOP switch

Operate the RUN/STOP switch on the front panel of the main unit to start and stop the PLC (refer to the right figure).

Turn the switch to RUN, and the PLC will start. Turn it to STOP, and the PLC will stop.

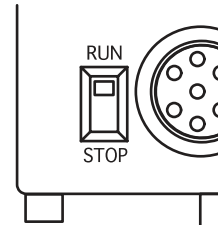

2. Running and stopping with general-purpose input (RUN terminal)

Operation with one switch (RUN)

One of the input terminals X000 to X017 of the main unit (X000 to X007 on a 16-point type unit) can be used as a RUN input terminal by a parameter setting (refer to the figure below).

When the specified input terminal is turned on, the PLC starts. When it is turned off, the PLC is started or stopped depending on the state of the built-in RUN/STOP switch.

→ For details, refer to "Kinds of Parameters and Settings" in Programming Manual.

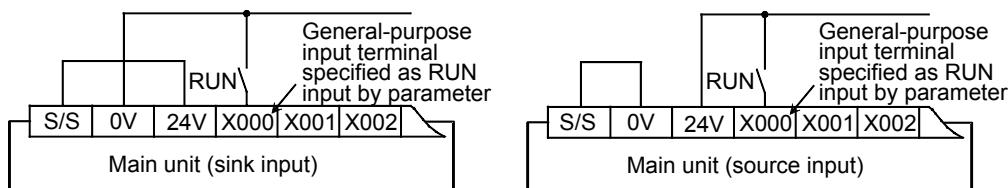

Operation with two switches (RUN and STOP)

The PLC can be started and stopped with individual RUN and STOP pushbutton switches.

For this operation, a sequence program using M8035 to M8037 is necessary.

→ For details, refer to "Operations of Special Devices" in Programming Manual.

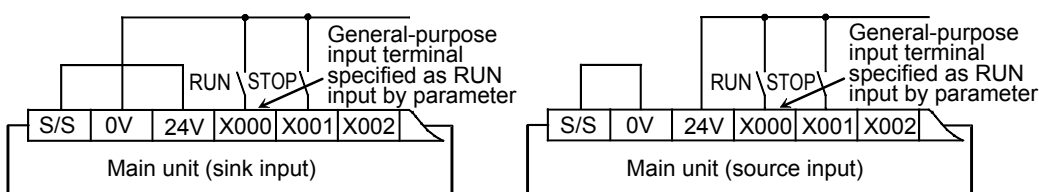

3. Starting and stopping by remote control from programming software

The programming software has a function to forcibly start and stop the PLC by remote control (remote RUN/STOP function).

However, when power is reapplied, the remote RUN/STOP function is disabled. The RUN/STOP status is then determined by the RUN/STOP switch or RUN terminal.

The remote operation for starting and stopping from the programming software is used in combination with the built-in RUN/STOP switch.

11	High-Speed Counters
12	Output Wiring
13	Wiring for Various Uses
14	Test Run, Maintenance, Troubleshooting
15	Input/Output Powered Extension Units
16	Input/Output Extension Blocks
17	Extension Power Supply Unit
18	Other Extension Units and Options
19	Display Module
20	Terminal Block

14.2.2 Use of several running/stopping methods

1. When the built-in RUN/STOP switch and the general-purpose RUN terminal are used

(without remote running/stopping operation from the programming software)

The RUN/STOP status of the PLC is determined by the conditions shown in the following table.

Condition of built-in RUN/STOP switch	Condition of general-purpose input terminal specified as RUN terminal by parameter	Status of PLC
RUN	OFF	RUN
	ON	RUN
STOP	OFF	STOP
	ON	RUN

Use either built-in RUN/STOP switch or the general input specified as RUN terminal.

(When specifying the general-purpose terminal as the RUN terminal, always set the built-in RUN/STOP switch to STOP.)

2. When the remote running/stopping operation from the programming software is performed

For this operation, keep both the built-in RUN/STOP switch and the general-purpose input RUN terminal in the STOP position.

If the stop command is given from the programming software after the PLC is started by either the built-in RUN/STOP switch or the general-purpose input RUN terminal, the PLC will be restored to the running status by giving the RUN command from the programming software. This can also be accomplished by setting the built-in RUN/STOP switch or the general-purpose input RUN terminal to STOP and then to RUN.

14.3 Operation and Test [Power ON and PLC Running]

14.3.1 Self-diagnostic function

When the PLC's power is turned on, its self-diagnostic function starts automatically. If there are no problems with the hardware, parameters or program, the PLC will start and the RUN command (refer to Section 14.2) is given (RUN LED is lit).

If any problems are found, the "ERROR" LED flashes or lights.

14.3.2 Test functions

Functions of the programming tool to turn on/off the PLC devices and change the current values/settings are effective or ineffective depending on the PLC status as shown below.

✓ : Effective △ : Conditionally effective – : Ineffective

Item		In running status	In stopped status
Forcible ON/OFF*1	Devices used in program	△*1	✓*1
	Devices not in use	✓	✓
Change of current values of timers, counters, data registers, extension registers, extension file registers and file registers*4	Devices used in program	△*2*3	✓*3
	Devices not in use	✓*3	✓*3
Change of settings of timers and counters*5	When the program memory is the built-in RAM	✓	✓
	When the program memory is in the memory cassette and the PROTECT switch is on	–	–
	When the program memory is in the memory cassette and the PROTECT switch is off	–	✓

*1. Forcible ON/OFF

- The forcible ON/OFF function is effective on the input relays (X), output relays (Y), auxiliary relays (M), state (S), timers (T) and counters (C). On the display module, the function cannot be operated for the input relays (X).
- The forcible ON/OFF function can turn on or off the devices only for one scan. While the PLC is running, the function is substantially effective in clearing the current values of the timers (T), counters (C), data registers (D), index registers (Z and V) and extension registers (R) and in controlling the SET/RST circuit and self-retaining circuit. (The operation to forcibly turn on timers is effective only when the timers are driven by the program.)
- The results of forcible ON/OFF operation performed while the PLC in the stopped state or performed for devices not used in the program are retained. However, the results of the operation performed for the input relays (X) are not retained because the relays refresh input even while the PLC is in the stopped state. (They are updated according to the input terminal conditions.)

*2. Since the current values may be changed according to MOV instruction in the program and the operation results, the most recently obtained values are retained.

*3. Only display modules can change the current value by the extension file register test function.

*4. The current values of the file registers stored in the program memory cannot be monitored or tested on the display module.

*5. Change of timer and counter settings

The settings of the timers (T) and counters (C) can be changed only when the timers are driven by the program.

11	High-Speed Counters
12	Output Wiring
13	Wiring for Various Uses
14	Test Run, Maintenance, Troubleshooting
15	Input/Output Powered Extension Units
16	Input/Output Extension Blocks
17	Extension Power Supply Unit
18	Other Extension Units and Options
19	Display Module
20	Terminal Block

14.3.3 Program modification function

The sequence program can be transferred while the PLC is running or in the stopped state as shown below.
 ✓ : Effective – : Ineffective

Item	In running status	In stopped status
Batch writing of file registers (D) and extension file registers (ER)	–	✓
Writing of program to PLC	Partial modification of program	✓ ^{*1}
	Modification of whole program (batch writing)	–
Writing of symbolic information to PLC ^{*2}	✓	✓
Writing of parameters to PLC	–	✓
Writing of comments to PLC	–	✓

*1. Since the writing function is used in running status, the programming tool must support the write during RUN function, such as GX Works2 or GX Developer.

→ **For the writing function during running, refer to Subsection 5.2.5.**

*2. GX Works2 Ver. 1.62Q or later is required to execute writing of the symbolic information.

→ **Refer to the GX Works2 Version 1 Operating Manual (Common) for the details on the writing of symbolic information.**

14.4 Maintenance and Periodic Inspection

This PLC does not incorporate consumable parts that are factors in the reduction of service life. However, the batteries and output relays (points of contact) have a limited life expectancy.

14.4.1 Procedures for checking model name

The model name of the main unit can be checked on the nameplate on the right side. After extension devices are connected, the nameplate cannot be seen. Check the model name in the following places.

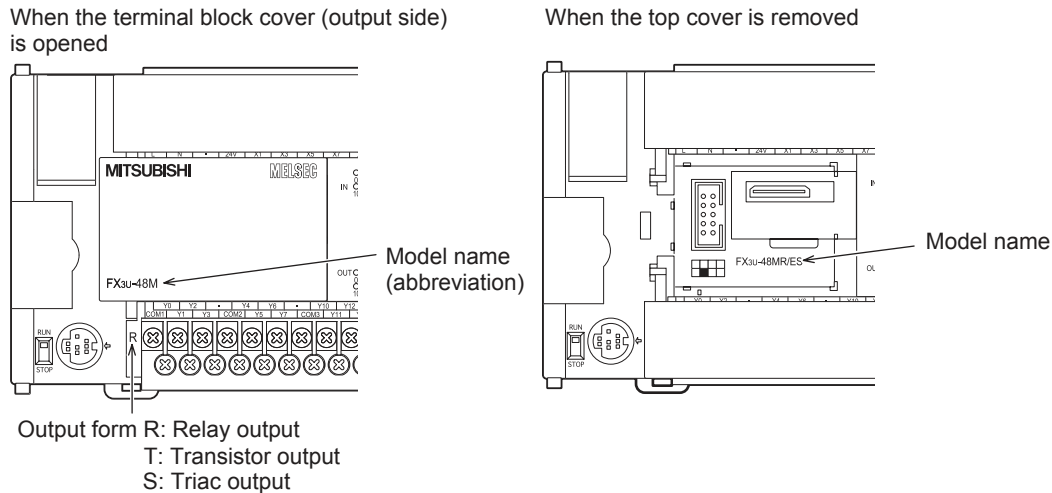

14.4.2 Periodic inspection - battery life, etc.

1. Battery

Part	Life
Model FX3U-32BL battery	Standard life: 5 years (at ambient temperature of 25°C (77°F))

Standard life of FX3U-32BL: 5 years (at ambient temperature of 25°C (77°F))

→ For frequency of replacement, refer to Subsection 22.3.1.

2. Other devices

When inspecting the battery, check the following points.

- Check that the temperature in the panel is not abnormally increased by other heat generating bodies or direct sunlight.
- Check that dust or conductive dust has not entered the panel.
- Check for loosening of wiring and other abnormalities.

11	High-Speed Counters
12	Output Wiring
13	Wiring for Various Uses
14	Test Run, Maintenance, Troubleshooting
15	Input/Output Powered Extension Units
16	Input/Output Extension Blocks
17	Extension Power Supply Unit
18	Other Extension Units and Options
19	Display Module
20	Terminal Block

14.4.3 Maintenance - product life of relay contacts

The product life of relay contacts varies considerably depending on the load type used. Take care that loads generating reverse electromotive force or rush current may cause poor contact or deposition of contacts which may lead to considerable reduction of the contact product life.

1. Inductive load

Inductive loads generate large reverse electromotive force between contacts at shutdown, which may cause arcing. At a fixed current consumption, as the power factor (phase between current and voltage) gets smaller, the arc energy gets larger.

- 1) Main unit, input/output powered extension units and input/output extension blocks

The standard life of contacts used for Inductive loads, such as contactors and solenoid valves, is 500,000 operations at 20 VA.

The following table shows the approximate life of a relay based on the results of an operation life test.

→ For the applicable models, refer to Chapter 3.

Test condition: 1 sec. ON / 1 sec.OFF

Load capacity		Contact life
20VA	0.2A/100V AC	3,000,000 times
	0.1A/200V AC	
35VA	0.35A/100V AC	1,000,000 times
	0.17A/200V AC	
80VA	0.8A/100V AC	200,000 times
	0.4A/200V AC	

- 2) FX Series terminal blocks

→ For the applicable models, refer to Subsection 3.1.10.

The standard life of contacts used for Inductive loads, such as contactors and solenoid valves, is 500,000 operations at 35 VA.

The following table shows the approximate life of a relay based on the results of an operation life test.

Test condition: 1 sec. ON / 1 sec.OFF

Load capacity		Contact life
35VA	0.35A/100V AC	3,000,000 times
	0.17A/200V AC	
80VA	0.8A/100V AC	1,000,000 times
	0.4A/200V AC	
120VA	1.2A/100V AC	200,000 times
	0.6A/200V AC	

The product life of relay contacts becomes considerably shorter than the above conditions when the rush overcurrent is shut down.

Please refer to the following measures regarding the inductive load.

→ For precautions on the main unit, input/output powered extension unit and input/output extension block, refer to Subsection 12.2.4 2.

→ For precautions on inductive loads for the terminal block, refer to Subsection 20.7.4 2.

Some types of inductive loads generate rush current 5 to 15 times the stationary current at activation. Make sure that the rush current does not exceed the current corresponding to the maximum specified resistance load.

2. Lamp load

Lamp loads generally generate rush current 10 to 15 times the stationary current. Make sure that the rush current does not exceed the current corresponding to the maximum specified resistance load.

3. Capacitive load

Capacitive loads can generate rush current 20 to 40 times the stationary current. Make sure that the rush current does not exceed the current corresponding to the maximum specified resistance load. Capacitive loads such as capacitors may be present in electronic circuit loads including inverters.

*About the maximum load specifications of the resistance load, refer to the specification for each model.

→ For specifications on the main unit, refer to Subsection 12.2.1.

→ For specifications on the input/output powered extension units, refer to Chapter 15.

→ For specifications on the input/output extension blocks, refer to Chapter 16.

→ For specifications on the terminal block, refer to Subsection 20.7.1.

14.4.4 Procedures for replacing battery

When the battery voltage drops while the PLC power is on, the "BATT" LED on the panel is lit in red, and M8005 and M8006 (latch) are turned on.

The memory can be retained for about one month after the lamps turn on. However, the operators may not immediately find the lamps to be on. Prepare a new battery promptly, and replace the battery with the new one.

→ For details on the specifications and functions of the battery, refer to Chapter 22 "FX3U-32BL (Battery)"

14.5 Troubleshooting with LEDs

When trouble occurs, check the LEDs on the PLC to identify the problem with the PLC.

14.5.1 POWER LED [on/flashing/off]

State of LED	State of PLC	Remedies
On	Power of the specified voltage is being correctly supplied to the power supply terminal.	The power supply is normal.
Flashing	One of the following problems may have occurred. <ul style="list-style-type: none"> Power of the specified voltage and current is not being supplied to the power supply terminal. External wiring is incorrect. Internal error of PLC 	<ul style="list-style-type: none"> Check the supply voltage. After disconnecting the cables other than the power cable, re-apply power to the PLC, and check for changes in the state. If the problem persists, consult your local Mitsubishi Electric representative.
Off	One of the following problems may have occurred. <ul style="list-style-type: none"> The power supply is off. External wiring is incorrect. Power of the specified voltage is not being supplied to the power supply terminal. The power cable is broken. 	<ul style="list-style-type: none"> If the power is not off, check the power supply and the power supply route. If power is being supplied correctly, consult your local Mitsubishi Electric representative. After disconnecting the cables other than the power cable, re-apply power to the PLC, and check for changes in the state. If the problem persists, consult your local Mitsubishi Electric representative.

14.5.2 BATT LED [on/off]

State of LED	State of PLC	Remedies
On	The battery voltage is low.	Immediately replace the battery. (Refer to Section 22.5.)
Off	The battery voltage is higher than the value set with D8006.	Normal

→ For details on the battery, refer to Chapter 22.

14.5.3 ERROR LED [on/flashing/off]

State of LED	State of PLC	Remedies
On	A watchdog timer error may have occurred, or the hardware of the PLC may be damaged.	<ol style="list-style-type: none"> 1) Stop the PLC, and re-apply power. If ERROR LED goes off, a watchdog timer error may have occurred. Take any of the following measures. <ul style="list-style-type: none"> - Review the program. The maximum value (D8012) of the scan time should not exceed the setting (D8000) of the watchdog timer. - Check that the input used for input interruption or pulse catch is not being abnormally turned on and off in one scan. - Check that the frequency of the pulse (duty of 50%) input to the high-speed counter does not exceed the specified range. - Add the WDT instructions. Add some WDT instructions to the program, and reset the watchdog timer several times in one scan. - Change the setting of the watchdog timer. Change the watchdog timer setting (D8000) in the program so that the setting is larger than the maximum value of the scan time (D8012). 2) Remove the PLC and supply power to it from another power supply on a desk. If the ERROR LED goes off, noise may have affected the PLC. Take the following measures. <ul style="list-style-type: none"> - Check the ground wiring, and reexamine the wiring route and installation location. - Fit a noise filter onto the power supply line. 3) If the ERROR LED does not go off even after the measures stated in (1) and (2) are taken, consult your local Mitsubishi Electric representative.
Flashing	One of the following errors has occurred in the PLC. <ul style="list-style-type: none"> • Parameter error • Syntax error • Ladder error 	Perform PLC diagnosis and program check with the programming tool. For the remedies, refer to Section 14.6 "Judgment by Error Codes and Representation of Error Codes".
Off	No errors that stop the PLC have occurred.	If the operations of the PLC are abnormal, perform PLC diagnosis and program check with the programming tool. An I/O error, Comms.error or Runtime error may have occurred.

11 High-Speed Counters

12 Output Wiring

13 Wiring for Various Uses

14 Test Run, Maintenance, Troubleshooting

15 Input/Output Powered Extension Units

16 Input/Output Extension Blocks

17 Extension Power Supply Unit

18 Other Extension Units and Options

19 Display Module

20 Terminal Block

14.6 Judgment by Error Codes and Representation of Error Codes

Error codes can be checked with the programming tool or on the display module (FX3U-7DM).

14.6.1 Operation and check on display module (FX3U-7DM)

- 1) Move the cursor to "ErrorCheck" pressing the + or - button on the menu screen (shown right).
For the menu configuration, refer to Section 19.6.
The buttons on the menu screen work as stated below.

Operation button	Operation
ESC	The screen returns to the top screen (time display).
-	The cursor moves upward. When the button is held for 1 second or more, the cursor moves quickly. When the cursor is in the uppermost position, the button is ineffective.
+	The cursor moves downward. When the button is held for 1 second or more, the cursor moves quickly. When the cursor is in the lowermost position, the button is ineffective.
OK	The flashing item at the cursor is selected.

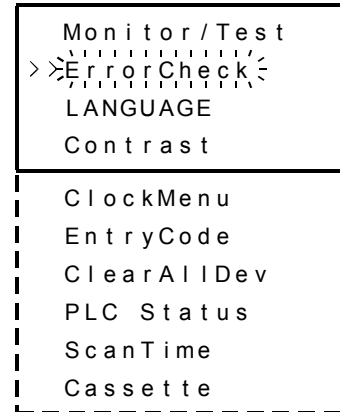

- 2) When the OK button is pressed, an error check is performed. The results are displayed on the error display screen (shown to the right).
Pressing the ESC button on the menu screen cancels the operation and returns the screen to the top screen (time display).
- 3) If some errors have occurred, the pages can be switched with the + or - button.

Operation button	Operation
ESC	The screen returns to the Menu screen.
-	1 error or less: Ineffective operation 2 errors or more: The previous page of the error display screen is displayed.
+	1 error or less: Ineffective operation 2 errors or more: The following page of the error display screen is displayed.
OK	The screen returns to the Menu screen.

When no errors have occurred

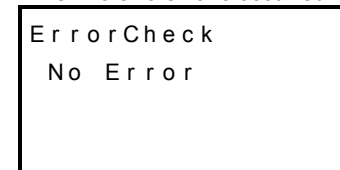

When one error has occurred

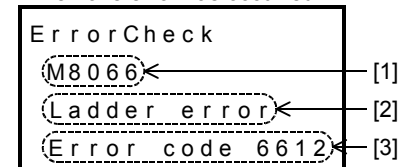

When more than one error has occurred

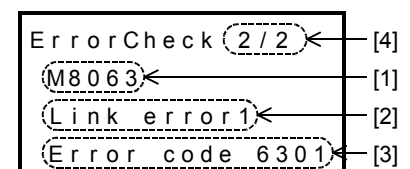
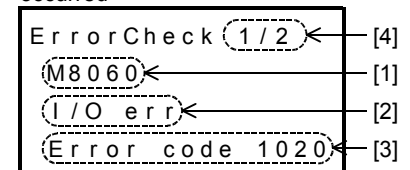

Displayed data

	Displayed data
[1]	Flag of occurred error
[2]	Error name
[3]	Error code
[4]	Number of simultaneously occurring errors (displayed only when more than one error has occurred)

- 4) Pressing the ESC button cancels the operation and returns the screen to the Menu screen.

14.6.2 Operation and check by GX developer

- 1 Connect the personal computer and the PLC.
- 2 Execute the PLC diagnosis.

Click [Diagnostics] → [PLC diagnostics] on the tool menu, and the diagnosis of PLC will start.

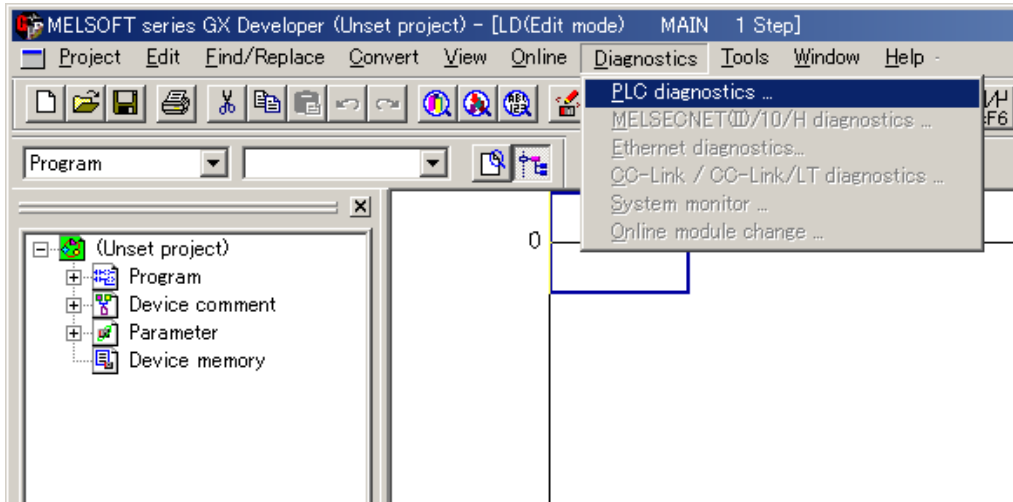

- 3 Check the results of diagnosis.

Display the following window to check the errors.

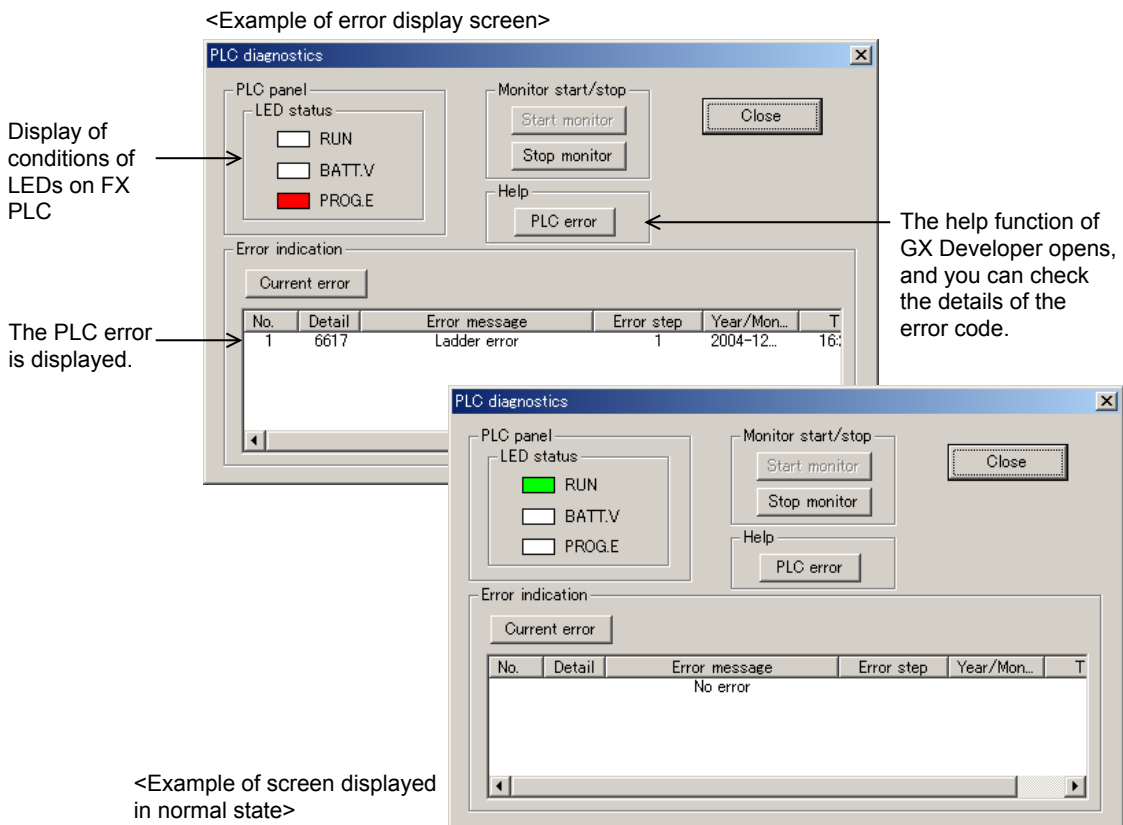

11	High-Speed Counters
12	Output Wiring
13	Wiring for Various Uses
14	Test Run, Maintenance, Troubleshooting
15	Input/Output Powered Extension Units
16	Input/Output Extension Blocks
17	Extension Power Supply Unit
18	Other Extension Units and Options
19	Display Module
20	Terminal Block

14.6.3 Representation of errors

Errors are represented in this manual, GX Works2, GX Developer, and the display module as shown in the following table.

- Comparison between this manual and GX Works2

This manual	GX Works2	
	SW□DNC-GXW2-E(Ver. 1.73B)	SW□DNC-GXW2-J(Ver. 1.73B)
I/O configuration error	I/O Configuration Error	I/O構成エラー
PLC hardware error	PLC Hardware Error	PCハードエラー
PLC/PP communication error	PLC/PP Communication Error	PC/PP通信エラー
Serial communication error 1 [ch1]	Link Error	リンクエラー
Serial communication error 2 [ch2]	Serial Communication Error 2[ch2]	シリアル通信エラー2[ch2]
Parameter error	Parameter Error	パラメータエラー
Syntax error	Syntax Error	文法エラー
Circuit error	Ladder Error	回路エラー
Operation error	Operation Error	演算エラー
Special block error	Special Block Error	特殊ブロックエラー
Special parameter error	Special Parameter Error	特殊パラメータエラー

- Comparison between this manual and GX Developer

This manual	GX Developer	
	SW□D5C-GPPW-E(Ver. 8.95Z)	SW□D5C-GPPW-J(Ver. 8.95Z)
I/O configuration error	I/O config err	I/O 構成エラー
PLC hardware error	PLC H/W error	PC ハードウェア エラー
PLC/PP communication error	PLC/PP comm err	PC/PP 通信 エラー
Serial communication error 1 [ch1]	Link error	リンク エラー
Serial communication error 2 [ch2]	Link Error 2	シリアル通信エラー (CH2)
Parameter error	Param error	パラメータ エラー
Syntax error	Syntax error	文法 エラー
Circuit error	Ladder error	回路 エラー
Operation error	Operation err	演算 エラー
Special block error	SFB Error	特殊ブロックエラー
Special parameter error	—	—

- Comparison between this manual and the display module

This manual	Display module	
	Display in English	Display in Japanese
I/O configuration error	I/O error	I/O構成エラー
PLC hardware error	PLC H/W error	PCハードエラー
PLC/PP communication error	Comms. error	PC/PP通信エラー
Serial communication error 1 [ch1]	Link error1	シリアル通信エラー1
Serial communication error 2 [ch2]	Link error2	シリアル通信エラー2
Parameter error	Parameter error	パラメータエラー
Syntax error	Grammer error	文法エラー
Circuit error	Ladder error	回路エラー
Operation error	Runtime error	演算エラー
Special block error	SFB error	特殊ブロックエラー
Special parameter error	—	—

14.6.4 Error Code List and Action

When a program error occurs in the PLC, the error code is stored in the special data registers D8060 to D8067, D8438, D8449 and D8489, and the error bit turns ON in the special data register D8166 as follows. Take action based on the following information.

Error code	PLC operation at error occurrence	Contents of error	Action				
I/O configuration error [M8060(D8060)]							
Ex-ample: 1020	Continues operation	<p>The head number of unconnected I/O device</p> <p>Example: When X020 is unconnected</p> <table border="1" style="margin-left: 20px;"> <tr> <td style="padding: 2px 5px;">1</td> <td style="padding: 2px 5px;">0</td> <td style="padding: 2px 5px;">2</td> <td style="padding: 2px 5px;">0</td> </tr> </table> <p style="margin-left: 20px;">BCD conversion value</p> <p style="margin-left: 20px;">Device number: 10 to 337</p> <p style="margin-left: 20px;">1: Input (X), 0: Output (Y)</p> <ul style="list-style-type: none"> • 1st to 3rd digits: Device number • 4th digit: I/O type (1 = input (X), 0 = output (Y)) <p>Example: When 1020 is stored in D8060 Inputs X020 and later are unconnected.</p>	1	0	2	0	Unconnected I/O relay numbers are programmed. The PLC continues its operation. Modify the program, check wiring connection, or add the appropriate unit/block.
1	0	2	0				
Serial communication error 2 [M8438 (D8438)]							
0000	—	No error					
3801	Continues operation	Parity, overrun or framing error	<ul style="list-style-type: none"> • Inverter communication, computer link and programming: Ensure the communication parameters are correctly set according to their applications. • N:N network, parallel link, etc.: Check programs according to the applications. • Remote maintenance: Ensure modem power is ON and check the settings of the AT commands. • Wiring: Check the communication cables for correct wiring. 				
3802		Communication character error					
3803		Communication data sum check error					
3804		Communication data format error					
3805		Command error					
3806		Communication time-out detected					
3807		Modem initialization error					
3808		N:N network parameter error					
3809		N:N Network setting error					
3812		Parallel link character error					
3813	Parallel link sum error	When the memory cassette is used, check whether it is mounted correctly. If the problem persists, something may be malfunctioning inside the PLC. Consult your local Mitsubishi Electric representative.					
3814	Parallel link format error						
3820	Inverter communication error						
3830	Memory cassette write error						
3840	Special adapter connection error	Check connection of the special adapter.					
PLC hardware error [M8061(D8061)]							
0000	—	No error					
6101	Stops operation	Memory access error	When the memory cassette is used, check whether it is mounted correctly. If the problem persists or if the memory cassette is not used, something may be malfunctioning inside the PLC. Consult your local Mitsubishi Electric representative.				
6102		Operation circuit error	<p>Isolate the PLC and supply power to it using a different power supply.</p> <p>If the ERROR LED turns OFF, noise may be affecting the PLC. Take the following measures.</p> <ul style="list-style-type: none"> - Check the ground wiring, and reexamine the wiring route and installation location. - Fit a noise filter onto the power supply line. <p>If the ERROR LED does not turn OFF even after the above actions are taken, consult your local Mitsubishi Electric representative.</p>				

11 High-Speed Counters
12 Output Wiring
13 Wiring for Various Uses
14 Test Run, Maintenance, Troubleshooting
15 Input/Output Powered Extension Units
16 Input/Output Extension Blocks
17 Extension Power Supply Unit
18 Other Extension Units and Options
19 Display Module
20 Terminal Block

Error code	PLC operation at error occurrence	Contents of error	Action
PLC hardware error [M8061(D8061)]			
6103	Stops operation	I/O bus error (M8069 = ON)	Verify that extension cables are correctly connected.
6104		Powered extension unit 24 V failure (M8069 = ON)	
6105		Watchdog timer error	Check user program. The scan time exceeds the value stored in D8000.
6106		I/O table creation error (CPU error)	When turning the power ON to the main unit, a 24V power failure occurs in a powered extension unit. (The error occurs if the 24V power is not supplied for 10 seconds or more after the main power is turned ON.)
6107		System configuration error	Check the number of the connected special function units/blocks. For certain special function units/blocks, the connectable number is limited.
PLC/PP communication error (D8062)			
0000	—	No error	
6201	Continues operation	Parity, overrun or framing error	Check the cable connection between the programming panel (PP) / programming device and the PLC. This error may occur when a cable is disconnected and reconnected during PLC monitoring.
6202		Communication character error	
6203		Communication data sum check error	
6204		Data format error	
6205		Command error	
6230		Memory cassette write error	
Serial communication error 1 [M8063 (D8063)]			
0000	—	No error	
6301	Continues operation	Parity, overrun or framing error	<ul style="list-style-type: none"> • Inverter communication, computer link and programming: Ensure that the communication parameters are correctly set according to their applications. • N:N network, parallel link, etc.: Check programs according to applications. • Remote maintenance: Ensure modem power is ON and check the settings of the AT commands. • Wiring: Check the communication cables for correct wiring.
6302		Communication character error	
6303		Communication data sum check error	
6304		Communication data format error	
6305		Command error	
6306		Communication time-out detected	
6307		Modem initialization error	
6308		N:N network parameter error	
6309		N:N Network setting error	
6312		Parallel link character error	
6313		Parallel link sum error	
6314		Parallel link format error	
6320		Inverter communication error	
6330		Memory cassette write error	
6340	Special adapter connection error	Check connection of the special adapter.	

Error code	PLC operation at error occurrence	Contents of error	Action	
Parameter error [M8064(D8064)]				
0000	—	No error		
6401	Stops operation	Program sum check error	<ul style="list-style-type: none"> • STOP the PLC, and correctly set the parameters. • Check that the following functions are not used with an unsupported PLC version when a memory cassette is attached: <ul style="list-style-type: none"> - Permanent PLC lock (supported in Ver. 2.61 or later) - Read-protect the execution program for block passwords (supported in Ver. 3.00 or later) - FX3U-FLROM-1M (supported in Ver. 3.00 or later) 	
6402		Memory capacity setting error		
6403		Latched device area setting error		
6404		Comment area setting error		
6405		File register area setting error		
6406		Special unit (BFM) initial value setting, positioning instruction setting sum check error		
6407		Special unit (BFM) initial value setting, positioning instruction setting error		
6409		Other setting error		
6420		Special parameter sum check error		<ul style="list-style-type: none"> • STOP the PLC, and correctly set the special parameters. • Set special parameters correctly, turn OFF the power, and then turn ON the power.
6421		Special parameters setting error		<ul style="list-style-type: none"> • Check the contents of the special parameter error code (D8489), confirm troubleshooting for special adapters/special blocks, and set special parameters correctly. • Set special parameters correctly, turn OFF the power, and then turn ON the power.
Syntax error [M8065(D8065)]				
0000	—	No error		
6501	Stops operation	Incorrect combination of instruction, device symbol and device number	During programming, each instruction is checked. If a syntax error is detected, modify the instruction correctly.	
6502		No OUT T or OUT C before setting value		
6503		<ul style="list-style-type: none"> • No setting value after OUT T or OUT C • Insufficient number of operands for an applied instruction 		
6504		<ul style="list-style-type: none"> • Same label number is used more than once. • Same interrupt input or high-speed counter input is used more than once. 		
6505		Device number is out of allowed range.		
6506		Invalid instruction		
6507		Invalid label number [P]		
6508		Invalid interrupt input [I]		
6509		Other error		
6510		MC nesting number error		
Circuit error [M8066(D8066)]				
0000	—	No error		
6610	Stops operation	LD, LDI is continuously used 9 times or more.	<p>This error occurs when a combination of instructions is incorrect in the entire circuit block or when the relationship between a pair of instructions is incorrect.</p> <p>Modify the instructions in the program mode so that their mutual relationship becomes correct.</p>	
6611		More ANB/ORB instructions than LD/LDI instructions		
6612		Less ANB/ORB instructions than LD/LDI instructions		
6613		MPS is continuously used 12 times or more.		
6614		No MPS instruction		
6615		No MPP instruction		
6616		No coil between MPS, MRD and MPP, or incorrect combination		
6617		Instruction below is not connected to bus line: STL, RET, MCR, P, I, DI, EI, FOR, NEXT, SRET, IRET, FEND or END		
6618		STL, MC or MCR can be used only in main program, but it is used elsewhere (e.g. in interrupt routine or subroutine).		

11	High-Speed Counters
12	Output Wiring
13	Wiring for Various Uses
14	Test Run, Maintenance, Troubleshooting
15	Input/Output Powered Extension Units
16	Input/Output Blocks
17	Extension Power Supply Unit
18	Other Extension Units and Options
19	Display Module
20	Terminal Block

Error code	PLC operation at error occurrence	Contents of error	Action	
Circuit error [M8066(D8066)]				
6619	Stops operation	Invalid instruction is used in FOR-NEXT loop: STL, RET, MC, MCR, I (interrupt pointer) or IRET.	This error occurs when a combination of instructions is incorrect in the entire circuit block or when the relationship between a pair of instructions is incorrect. Modify the instructions in the program mode so that their mutual relationship becomes correct.	
6620		FOR-NEXT instruction nesting level exceeded		
6621		Numbers of FOR and NEXT instructions do not match.		
6622		No NEXT instruction		
6623		No MC instruction		
6624		No MCR instruction		
6625		STL instruction is continuously used 9 times or more.		
6626		Invalid instruction is programmed within STL-RET loop: MC, MCR, I (interrupt pointer), SRET or IRET.		
6627		No STL instruction		
6628		Invalid instruction is used in main program: I (interrupt pointer), SRET or IRET		
6629		No P or I (interrupt pointer)		
6630		No SRET or IRET instruction STL-RET or MC-MCR instructions in subroutine		
6631		SRET programmed in invalid location		
6632	FEND programmed in invalid location			
Operation error [M8067(D8067)]				
0000	—	No error		
6701	Continues operation	<ul style="list-style-type: none"> No jump destination (pointer) for CJ or CALL instruction Label is undefined or out of P0 to P4095 due to indexing Label P63 is executed in CALL instruction; cannot be used in CALL instruction as P63 is for jumping to END instruction. 	This error occurs in the execution of operation. Review the program and check the contents of the operands used in applied instructions. Even if the syntax or circuit design is correct, an operation error may still occur. For example: "T200Z" itself is not an error. But if Z had a value of 400, the timer T600 would attempt to be accessed. This would cause an operation error since there is no T600 device available.	
6702		CALL instruction nesting level is 6 or more		
6703		Interrupt nesting level is 3 or more		
6704		FOR-NEXT instruction nesting level is 6 or more.		
6705		Operand of applied instruction is inapplicable device.		
6706		Device number range or data value for operand of applied instruction exceeds limit.		
6707		File register is accessed without parameter setting of file register.		
6708		FROM/TO instruction error		This error occurs in the execution of operation. <ul style="list-style-type: none"> Review the program and check the contents of the operands used in applied instructions. Verify that the specified buffer memories exist in the counterpart equipment. Verify that extension cables are correctly connected.
6709		Other (e.g. improper branching)		This error occurs in the execution of operation. Review the program and check the contents of the operands used in applied instructions. Even if the syntax or circuit design is correct, an operation error may still occur. For example: "T200Z" itself is not an error. But if Z had a value of 400, the timer T600 would attempt to be accessed. This would cause an operation error since there is no T600 device available.

Error code	PLC operation at error occurrence	Contents of error	Action
Operation error [M8067(D8067)]			
6710	Continues operation	Mismatch among parameters	This error occurs when the same device is used within the source and destination in a shift instruction, etc.
6730		Incorrect sampling time (TS) ($TS \leq 0$)	<PID instruction is stopped.> This error occurs in the parameter setting value or operation data executing PID instruction. Check the contents of the parameters.
6732		Incompatible input filter constant (α) ($\alpha < 0$ or $100 \leq \alpha$)	
6733		Incompatible proportional gain (KP) ($KP < 0$)	
6734		Incompatible integral time (TI) ($TI < 0$)	
6735		Incompatible derivative gain (KD) ($KD < 0$ or $201 \leq KD$)	
6736		Incompatible derivative time (TD) ($TD < 0$)	
6740		Sampling time (TS) \leq Scan time	<Auto tuning is continued.> The operation is continued in the condition "sampling time (TS) = cyclic time (scan time)".
6742		Variation of measured value exceeds limit. ($\Delta PV < -32768$ or $+32767 < \Delta PV$)	<PID operation is continued.> The operation is continued with each parameter set to the maximum or minimum value.
6743		Deviation exceeds limit. ($EV < -32768$ or $+32767 < EV$)	
6744		Integral result exceeds limit. (Outside range from -32768 to $+32767$)	
6745		Derivative value exceeds limit due to derivative gain (KD).	
6746		Derivative result exceeds limit. (Outside range from -32768 to $+32767$)	
6747		PID operation result exceeds limit. (Outside range from -32768 to $+32767$)	
6748		PID output upper limit set value < PID output lower limit set value.	<Transpose of output upper limit value and output lower limit value. → PID operation is continued.> Check whether the target setting contents are correct.
6749	Abnormal PID input variation alarm set value or output variation alarm set value (Set value < 0)	<Alarm output is not given. → PID operation is continued.> Check whether the target setting contents are correct.	
6750	<Step response method> Improper auto tuning result	<Auto tuning is finished. → PID operation is started.> <ul style="list-style-type: none"> The deviation at start of auto tuning is 150 or less. The deviation at end of auto tuning is 1/3 or more of the deviation at start of auto tuning. Check the measured value and target value, and then execute auto tuning again.	
6751	<Step response method> Auto tuning operation direction mismatch	<Auto tuning is forcibly finished. → PID operation is not started.> The operation direction estimated from the measured value at the start of auto tuning was different from the actual operation direction of the output during auto tuning. Correct the relationship among the target value, output value for auto tuning, and the measured value, and then execute auto tuning again.	
6752	<Step response method> Improper auto tuning operation	<Auto tuning is finished. → PID operation is not started.> Because the set value was fluctuated during auto tuning, auto tuning was not executed correctly. Set the sampling time to a value larger than the output change cycle, or set a larger value for the input filter constant. After changing the setting, execute auto tuning again.	

11	High-Speed Counters
12	Output Wiring
13	Wiring for Various Uses
14	Test Run, Maintenance, Troubleshooting
15	Input/Output Powered Extension Units
16	Input/Output Extension Blocks
17	Extension Power Supply Unit
18	Other Extension Units and Options
19	Display Module
20	Terminal Block

Error code	PLC operation at error occurrence	Contents of error	Action
Operation error [M8067(D8067)]			
6753	Continues operation	<Limit cycle method> Abnormal output set value for auto tuning [ULV (upper limit) ≤ LLV (lower limit)]	<Auto tuning is forcibly finished. → PID operation is not started.>
6754		<Limit cycle method> Abnormal PV threshold (hysteresis) set value for auto tuning (SHPV < 0)	Check whether the target setting contents are correct.
6755		<Limit cycle method> Abnormal auto tuning transfer status (Data of device controlling transfer status is abnormally overwritten.)	<Auto tuning is forcibly finished. → PID operation is not started.> Ensure that devices occupied by PID instruction are not overwritten in the program.
6756		<Limit cycle method> Abnormal result due to excessive auto tuning measurement time ($\tau_{on} > \tau$, $\tau_{on} < 0$, $\tau < 0$)	<Auto tuning is forcibly finished. → PID operation is not started.> The auto tuning time is longer than necessary. Increase the difference (ULV - LLV) between the upper limit and lower limit of the output value for auto tuning, set a smaller value to the input filter constant (α), or set a smaller value to the PV threshold (SHPV) for auto tuning, and then check the result for improvement.
6757		<Limit cycle method> Auto tuning result exceeds proportional gain. (KP = outside range from 0 to 32767)	<Auto tuning is finished (KP = 32767). → PID operation is started.> The variation of the measured value (PV) is small compared with the output value. Multiply the measured value (PV) by "10" so that the variation of the measured value will increase during auto tuning.
6758		<Limit cycle method> Auto tuning result exceeds integral time. (TI = outside range from 0 to 32767)	<Auto tuning is finished (KP = 32767). → PID operation is started.> The auto tuning time is longer than necessary.
6759		<Limit cycle method> Auto tuning result exceeds derivative time. (TD = outside range from 0 to 32767)	Increase the difference (ULV - LLV) between the upper limit and lower limit of the output value for auto tuning, set a smaller value to the input filter constant (α), or set a smaller value to the PV threshold (SHPV) for auto tuning, and then check the result for improvement.
6760		ABS data read from servo sum check error	Check servo wiring and parameter setting. Also check ABS instruction.
6762		Port specified by inverter communication instruction is already used in another communication.	Check to make sure the port is not specified by another instruction.
6763		1) Input (X) specified by DSZR, DVIT or ZRN instruction is already used in another instruction. 2) The interrupt signal device for DVIT instruction is outside the allowable setting range.	1) Check to make sure the input (X), as specified by DSZR, DVIT or ZRN instruction, is not being used for the following purposes: - Input interrupt (including the delay function) - High-speed counter C235 to C255 - Pulse catch M8170 to M8177 - SPD instruction 2) Check the contents of D8336 for the correct interrupt signal specification for DVIT instruction.
6764		Pulse output number is already used in a positioning instruction or pulse output instruction (PLSY, PWM, etc.).	Check to make sure the pulse output destination is not being driven by another positioning instruction.
6765		Number of applied instruction exceeds limit.	The number of times an applied instruction is used in the program exceeds the specified limit.
6770		Memory cassette write error	When the memory cassette is used, check whether it is mounted correctly. If the problem persists, something may be malfunctioning inside the PLC. Consult your local Mitsubishi Electric representative.

Error code	PLC operation at error occurrence	Contents of error	Action	
Operation error [M8067(D8067)]				
6771	Continues operation	Memory cassette is not connected.	Check whether the memory cassette is mounted correctly.	
6772		Memory cassette is write protected.	The write-protect switch of the memory cassette was set to ON when data was transferred to the flash memory.	
6773		Access error to flash memory during writing in RUN mode	While data was written in the RUN mode, data was transferred to (read from or written to) the flash memory.	
Special block error [M8449 (D8449)]				
<input type="checkbox"/> 020* ¹	Continues operation	General data sum error	Verify that extension cables are correctly connected.	
<input type="checkbox"/> 021* ¹		General data message error		
<input type="checkbox"/> 022* ¹		System access error		
<input type="checkbox"/> 025* ¹		Access sum error in other station via CC-Link		
<input type="checkbox"/> 026* ¹		Message error in other station via CC-Link		
<input type="checkbox"/> 030* ¹		General data writing error to memory cassette	When the memory cassette is used, check whether it is mounted correctly. If the problem persists, something may be malfunctioning inside the PLC. Consult your local Mitsubishi Electric representative.	
<input type="checkbox"/> 080* ¹		FROM/TO error	This error occurs in the execution of operation. <ul style="list-style-type: none"> Review the program and check the contents of the operands used in applied instructions. Verify that the specified buffer memories exist in the counterpart equipment. Verify that extension cables are correctly connected. 	
<input type="checkbox"/> 090* ¹		Peripheral equipment access error	<ul style="list-style-type: none"> Check the cable connection between the programming panel (PP) / programming device and the PLC. Verify that extension cables are correctly connected. 	
Special parameter error [M8489 (D8489)]				
<input type="checkbox"/> 01* ²		Continues operation	Special parameter setting time-out error	Turn OFF the power, and check the power supply and connection of special adapters/special blocks.
<input type="checkbox"/> 02* ²	Special parameter setting error		Special parameters are set improperly. <ul style="list-style-type: none"> Confirm troubleshooting for special adapters/special blocks, and set special parameters correctly. Set special parameters correctly, turn OFF the power, and then turn ON the power. 	
<input type="checkbox"/> 03* ²	Special parameter transfer target unconnected error		Special parameters are set, but special adapters/special blocks are not connected. Check whether special adapters/special blocks are connected.	
<input type="checkbox"/> 04* ²	Special parameter unsupported function		Check that special parameters with unsupported settings are not set for connected special adapters/special blocks.	

*1. The unit number 0 to 7 of the special function unit/block error is put in .

*2. "" indicates the following values for each special adapter/special block where an error has occurred.
If an error has occurred in 2 or more special adapters/special blocks, "" indicates the lowest unit number among the special adapters/special blocks in which an error has occurred.

Value of <input type="checkbox"/> <input type="checkbox"/> (decimal)	Special adapter/special block where an error has occurred
00	Special block (Unit number 0)
10	Special block (Unit number 1)
20	Special block (Unit number 2)
30	Special block (Unit number 3)
40	Special block (Unit number 4)
50	Special block (Unit number 5)
60	Special block (Unit number 6)
70	Special block (Unit number 7)
81	Special adapter (Communication channel 1)
82	Special adapter (Communication channel 2)

Error bit	PLC operation at error occurrence	Contents of error	Action
Special block error condition [D8166]			
b0	Continues operation	Unit 0 access error	This error occurs when an operation is executed or when the END instruction is executed. <ul style="list-style-type: none"> • Review the program and check the contents of the operands used in applied instructions. • Verify that the specified buffer memories exist in the counterpart equipment. • Verify that extension cables are correctly connected.
b1		Unit 1 access error	
b2		Unit 2 access error	
b3		Unit 3 access error	
b4		Unit 4 access error	
b5		Unit 5 access error	
b6		Unit 6 access error	
b7		Unit 7 access error	
b8 to b15	—	Not used	

14.7 Troubleshooting

- For the procedures on running and stopping the PLC, refer to Section 14.2.
- For the procedures on operating the display module, refer to Chapter 19.
- For the procedures on operating peripheral devices, refer to the manuals for the peripheral devices.

14.7.1 Output does not operate (main unit and input/output extension blocks)

1. Output does not turn on.

Stop the PLC, and forcibly turn the inoperable output on then off with a peripheral device or the display module to check its operation.

Check for troubles with external wiring.

- When the output operates
The output may be turned off unintentionally in the program. Reexamine the program.
(Duplicate coil or RST instructions)
- When the output does not operate
Check the configuration of the connected devices and the connection of the extension cables.
If the configuration of the external wiring and connected devices and the connection of the extension cables are acceptable, the output circuit may be damaged.
Consult your local Mitsubishi Electric representative.

2. Output does not turn off.

Stop the PLC, and check that the output turns off.

Check for trouble with external wiring.

→ For the procedures on running and stopping the PLC, refer to Section 14.2.

- When the output turns off
The output may be turned on unintentionally in the program.
Check that there are no duplicate coils in the program.
- When the output does not turn off
The output circuit may be damaged. Consult your local Mitsubishi Electric representative.

14.7.2 24V DC input does not operate (main unit and input/output extension blocks)

1. Input does not turn on.

Disconnect the external wiring and connect the S/S terminal and the 0V terminal or the 24V terminal.

Short-circuit the 0V terminal or 24V terminal not connected to the S/S terminal and the input terminal, then check the input display LED or a peripheral device to confirm that the input turns on.

	Measures
When input turns on	Check that the input device does not have a built-in diode or parallel resistance. If so, refer to Subsection 10.2.3.
When input does not turn on	Measure the voltage between the 0V terminal or 24V terminal not connected to the S/S terminal and the input terminal with a tester to confirm that the voltage is 24V DC. • Check the configuration of the external wiring and connected devices and the connection of the extension cables.

2. Input does not turn off.

Check for leakage current from input devices.

If the leakage current is 1.5mA or more, it is necessary to connect a bleeder resistance.

→ For details on the measures, refer to Subsection 10.2.3.

11	High-Speed Counters
12	Output Wiring
13	Wiring for Various Uses
14	Test Run, Maintenance, Troubleshooting
15	Input/Output Powered Extension Units
16	Input/Output Extension Blocks
17	Extension Power Supply Unit
18	Other Extension Units and Options
19	Display Module
20	Terminal Block

14.7.3 Cautions on registering a keyword

1. Cautions on registering a keyword

The keyword limits access to the program prepared by the user from peripheral devices.

Retain the keyword carefully.

If you forget the keyword, you cannot operate the PLC online from a programming tool depending on the type of programming tool and the registered keyword.

2. Cautions on using peripheral devices not supporting the second keyword

Sequence programs for which the second keyword has been registered cannot be all-cleared using a peripheral device that does not support the second keyword (such as GX Developer earlier than Ver. 8.24A).

3. Cautions on using peripheral devices not supporting the customer keyword

Sequence programs for which the customer keyword has been registered cannot be all-cleared using a peripheral device that does not support the customer keyword (such as GX Developer earlier than Ver. 8.89T).

4. Non-resettable protect function

When the non-resettable protect function is set, the protect function cannot be reset.

5. Cautions on using a memory cassette in which keywords are already set

In FX3U PLCs whose version is earlier than Ver. 2.61, do not use a memory cassette in which the customer keyword or permanent PLC lock is set.

If a memory cassette where the permanent PLC lock is set is used in an FX3U PLC whose version is earlier than Ver. 2.61, the PLC does not run normally.

If the PLC memory is cleared or the keyword is canceled in a PLC whose version is earlier than Ver. 2.61 for a memory cassette where the customer keyword or permanent PLC lock are set, access restrictions of the keyword may not be removed normally.

14.7.4 Cautions on using block password

Note the following cautions when using a block password for which the setting "Read-protect the execution program." is valid.

- In a PLC that has been written to by a computer using a project including a block password for which the setting "Read-protect the execution program." is valid, restoration of programs is enabled only when the PLC is able to store symbolic information.
To allow for editing of the program by peripheral devices that do not support symbolic information (only supported in GX Works2 Ver. 1.62Q or later), do not use a block password for which the setting "Read-protect the execution program." is valid.
- When a peripheral device tries to read an execution program from a PLC that has been written to by a computer using a project including a block password for which the setting "Read-protect the execution program." is valid, a communication error occurs and reading is disabled.
- For writing a program using a peripheral device other than GX Works2 (Ver. 1.62Q or later) to a PLC that has been written to by a computer using a project including a block password for which the setting "Read-protect the execution program." is valid, execute "Clear PLC memory" to clear programs before writing.
If a program is written without executing "Clear PLC memory" in advance, the written program cannot be read.
- It is not possible to write programs including a block password for which the setting "Read-protect the execution program." is valid to a FX3U PLC whose version is earlier than Ver. 3.00.
- If a memory cassette storing a program that includes a block password for which the setting "Read-protect the execution program." is valid is used for a FX3U PLC whose version is earlier than Ver. 3.00, the FX3U PLC does not run normally.

15. FX2N-32/48E*-* (Input/Output Powered Extension Units)

DESIGN PRECAUTIONS



- Make sure to have the following safety circuits outside of the PLC to ensure safe system operation even during external power supply problems or PLC failure. Otherwise, malfunctions may cause serious accidents.
 - 1) Most importantly, have the following: an emergency stop circuit, a protection circuit, an interlock circuit for opposite movements (such as normal vs. reverse rotation), and an interlock circuit (to prevent damage to the equipment at the upper and lower positioning limits).
 - 2) Note that when the PLC CPU detects an error, such as a watchdog timer error, during self-diagnosis, all outputs are turned off. Also, when an error that cannot be detected by the PLC CPU occurs in an input/output control block, output control may be disabled. External circuits and mechanisms should be designed to ensure safe machinery operation in such a case.
 - 3) Note that the output current of the 24V DC service power supply varies depending on the model and the absence/presence of extension blocks. If an overload occurs, the voltage automatically drops, inputs in the PLC are disabled, and all outputs are turned off. External circuits and mechanisms should be designed to ensure safe machinery operation in such a case.
 - 4) Note that when an error occurs in a relay, triac or transistor output device, the output could be held either on or off. For output signals that may lead to serious accidents, external circuits and mechanisms should be designed to ensure safe machinery operation in such a case.

DESIGN PRECAUTIONS



- Do not bundle the control line together with or lay it close to the main circuit or power line. As a guideline, lay the control line at least 100mm (3.94") or more away from the main circuit or power line. Noise may cause malfunctions.

WIRING PRECAUTIONS



- Make sure to cut off all phases of the power supply externally before attempting installation or wiring work. Failure to do so may cause electric shock or damage to the product.
- Make sure to attach the terminal cover, offered as an accessory, before turning on the power or initiating operation after installation or wiring work. Failure to do so may cause electric shock.

11

High-Speed
Counters

12

Output Wiring

13

Wiring for
Various Uses

14

Test Run,
Maintenance,
Troubleshooting

15

Input/Output
Powered
Extension Units

16

Input/Output
Extension
Blocks

17

Extension
Power Supply
Unit

18

Other Extension
Units and
Options

19

Display Module

20

Terminal Block

WIRING PRECAUTIONS



- Do not supply power to the [24+] and [24V] terminals (24V DC service power supply) on the main unit or extension units.
Doing so may cause damage to the product.
- Perform class D grounding (grounding resistance: 100 Ω or less) to the grounding terminal on the main unit and extension units with a wire 2 mm² or thicker.
Do not use common grounding with heavy electrical systems (refer to Section 9.4).
- Connect the AC power supply wiring to the dedicated terminals described in this manual.
If an AC power supply is connected to a DC input/output terminal or DC power supply terminal, the PLC will burn out.
- Connect the DC power supply wiring to the dedicated terminals described in this manual.
If an AC power supply is connected to a DC input/output terminal or DC power supply terminal, the PLC will burn out.
- Do not wire vacant terminals externally.
Doing so may damage the product.
- When drilling screw holes or wiring, make sure that cutting and wiring debris do not enter the ventilation slits.
Failure to do so may cause fire, equipment failures or malfunctions.
- Make sure to properly wire the FX3U Series main unit and FX0N/FX2N/FX3U Series extension equipment in accordance with the following precautions.
Failure to do so may cause electric shock, equipment failures, a short-circuit, wire breakage, malfunctions, or damage to the product.
 - The disposal size of the cable end should follow the dimensions described in the manual.
 - Tightening torque should follow the specifications in the manual.

15.1 Outline

An input/output powered extension unit is used to expand inputs/outputs.

Power can be supplied to subsequent extension blocks from an input/output powered extension unit with a built-in 24V DC power supply.

An input/output powered extension unit is required when the capacity of the main unit's built-in power supply is insufficient for the current consumption demands of the extension blocks.

15.1.1 Product configuration

There are various types of input/output powered extension units. They differ in supply voltage, number of input/output points, input form, output form and connection type.

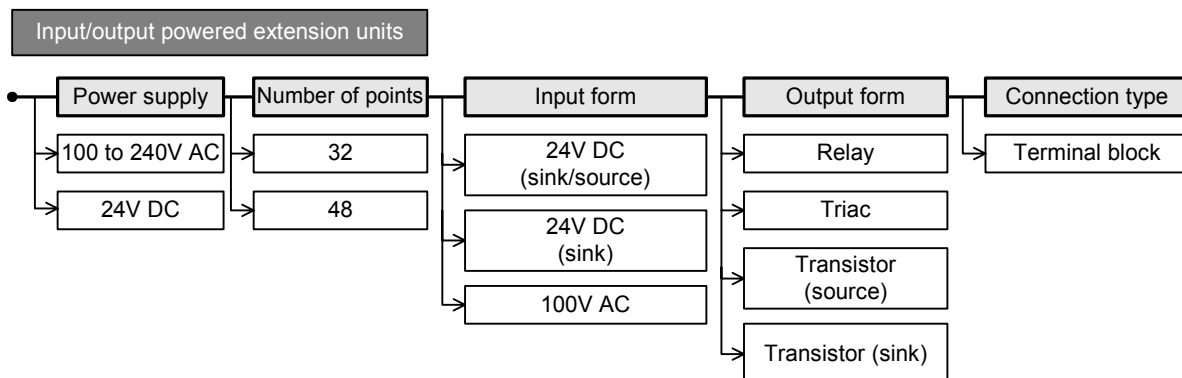

15.1.2 Product list

Each model of input/output powered extension unit has a sink and source type and a sink type. If you intend to add input/output powered extension units, we recommend you to add the same types of units as the main unit or the sink and source type.

→ For details on sink and source, refer to Subsection 10.1.1.

[Sink] :Sink [-common], **[Source]** :Source [+common]

Model	Input			Output			Connection type
	Type	Number of points	Common wiring system	Type	Number of points	Common wiring system	
AC power supply common to 24V DC sink and source input							
FX2N-32ER-ES/UL	24V DC	16	[Sink] [Source]	Relay	16	-	Terminal block
FX2N-48ER-ES/UL		24	[Sink] [Source]		24	-	
FX2N-32ET-ESS/UL		16	[Sink] [Source]	Transistor	16	[Source]	
FX2N-48ET-ESS/UL		24	[Sink] [Source]		24	[Source]	
AC power supply only for 24V DC sink input							
FX2N-32ER	24V DC	16	[Sink]	Relay	16	-	Terminal block
FX2N-48ER		24	[Sink]		24	-	
FX2N-32ES		16	[Sink]	Transistor	16	-	
FX2N-32ET		16	[Sink]		16	[Sink]	
FX2N-48ET		24	[Sink]		24	[Sink]	
AC power supply only for 100V AC							
FX2N-48ER-UA1/UL	100V AC	24	-	Relay	24	-	Terminal block
DC power supply common to 24V DC sink and source input							
FX2N-48ER-DS	24V DC	24	[Sink] [Source]	Relay	24	-	Terminal block
FX2N-48ET-DSS			[Sink] [Source]	Transistor		[Source]	
DC power supply only for 24V DC sink input							
FX2N-48ER-D	24V DC	24	[Sink]	Relay	24	-	Terminal block
FX2N-48ET-D			[Sink]	Transistor		[Sink]	

11 High-Speed Counters
12 Output Wiring
13 Wiring for Various Uses
14 Test Run, Maintenance, Troubleshooting
15 Input/Output Powered Extension Units
16 Input/Output Extension Blocks
17 Extension Power Supply Unit
18 Other Extension Units and Options
19 Display Module
20 Terminal Block

15.2 Power Supply Specifications (Power Supply Input/24V DC Service Power Supply)

Item		FX2N-32ER-ES/UL FX2N-32ET-ESS/UL	FX2N-32ER FX2N-32ES FX2N-32ET	FX2N-48ER-ES/UL FX2N-48ET-ESS/UL	FX2N-48ER FX2N-48ET
Classification		FX2N powered extension unit			
Supply voltage		100 to 240V AC			
Allowable supply voltage range		85 to 264V AC			
Rated frequency		50/60 Hz			
Power fuse		250V 3.15 A(3 A)		250V 5 A	
Rush current	100V AC	Up to 40 A, 5 ms or less			
	200V AC	Up to 60 A, 5 ms or less			
Power consumption		30 W		35 W	
24V DC service power supply	Without extension block	24V DC, 250 mA or less		24V DC, 460 mA or less	
	With extension block	When input/output extension blocks are connected, 24V DC service power is consumed by them. → For details, refer to Section 6.6.			
Connection type		Removable terminal block (M3 screw)			

Item		FX2N-48ER-UA1/UL	FX2N-48ER-DS FX2N-48ET-DSS	FX2N-48ER-D FX2N-48ET-D
Classification		FX2N powered extension unit		
Supply voltage		100 to 240V AC	24V DC	
Allowable supply voltage range		85 to 264V AC	+20%, -30%	
Power fuse		250V 5 A		
Rush current	100V AC	Up to 40 A, 5 ms or less	-	
	200V AC	Up to 60 A, 5 ms or less	-	
Power consumption		35 W	30 W	
24V DC service power supply		None		
Connection type		Removable terminal block (M3 screw)		

15.2.1 Weight, accessories, etc.

Item	FX2N-32ER-ES/UL FX2N-32ET-ESS/UL	FX2N-32ER FX2N-32ES FX2N-32ET	FX2N-48ER-ES/UL FX2N-48ET-ESS/UL FX2N-48ER-DS FX2N-48ET-DSS	FX2N-48ER FX2N-48ET FX2N-48ER-D FX2N-48ET-D	FX2N-48ER- UA1/UL
Weight	0.65 kg (1.43 lbs)		0.85 kg (1.87 lbs)		1.00 kg (2.2 lbs)
Accessories	<ul style="list-style-type: none"> Terminal protective cover (2 pcs.) (Fitted to FX2N-32ER-ES/UL, FX2N-32ET-ESS/UL, FX2N-48ER-ES/UL, FX2N-48ET-ESS/UL and FX2N-48ER-UA1/UL, FX2N-48ER-DS, FX2N-48ET-DSS) Extension cable (55 mm (2.16")) Optional extension cables (FX0N-30EC and FX0N-65EC) are available. Input/output number label 				
Others	<ul style="list-style-type: none"> The terminal block uses M3 terminal screws. Installation of the DIN46277 (35 mm (1.37") wide) rail or screws. 				

15.2.2 Part names

1. Front

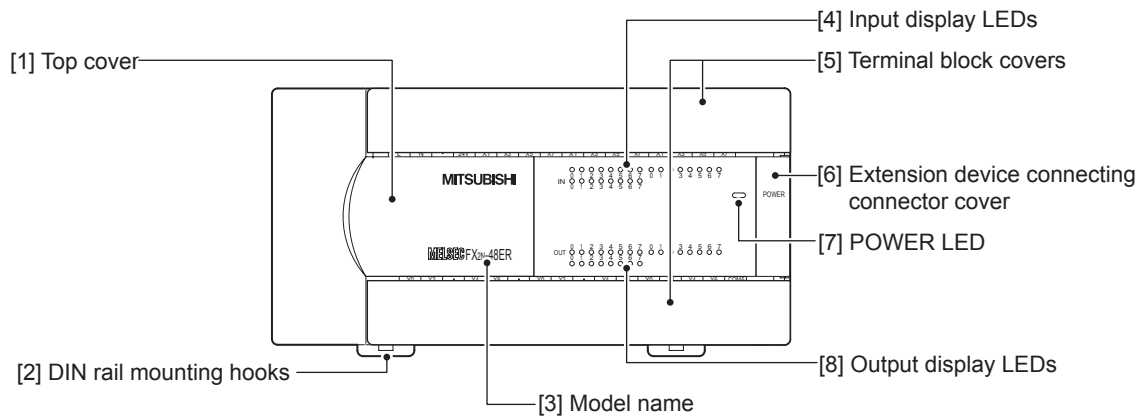

- [1] **Top cover**
When adding this to the main unit, connect the supplied extension cable or the optional extension cable to the connector under this top cover.
- [2] **DIN rail mounting hooks (2 places)**
The input/output powered extension unit can be installed on DIN rail (35 mm (1.38") wide).
- [3] **Model name (abbreviation)**
The model name of the input/output powered extension unit is indicated.
- [4] **Input display LEDs (red)**
When an input terminal (X0, X1, etc.) is turned on, the corresponding LED lamps are also turned on.
The input numbers change depending on input/output allocation.
The input/output powered extension unit (48 points type) assigns input numbers in ascending order from A→B→C below.

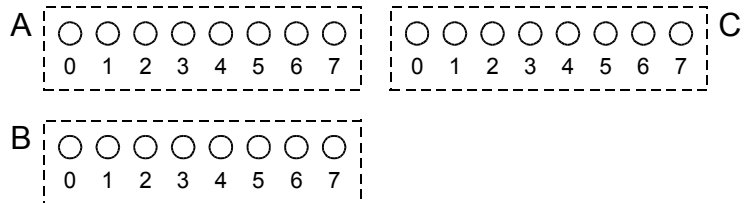

- [5] **Terminal block covers**
The covers can be opened about 90° for wiring.
Keep the covers closed while the PLC is running (the unit power is on).
- [6] **Extension device connecting connector cover**
Connect the extension cable of input/output powered extension unit/block or special function unit/block to the extension device connecting connector under this cover.
FX3U Series extension devices, FX2N Series extension devices and FX0N Series special function devices are compatible and can be connected.
→ **For details on extension devices, refer to Chapter 15, Chapter 16 and Section 18.1.**
- [7] **POWER LED (green)**
The LED lamp is on (green) while the power supply terminal is on.
- [8] **Output display LEDs (red)**
When an output terminal (Y0, Y1, etc.) is turned on, the corresponding LED lamps are also turned on. The output numbers change depending on input/output allocation.
The input/output powered extension unit (48 points type) assigns output numbers in ascending order from A→B→C below.

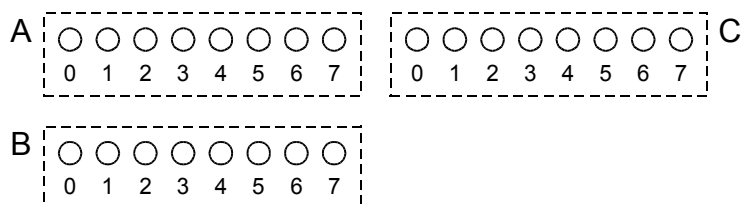

When the terminal block covers are open

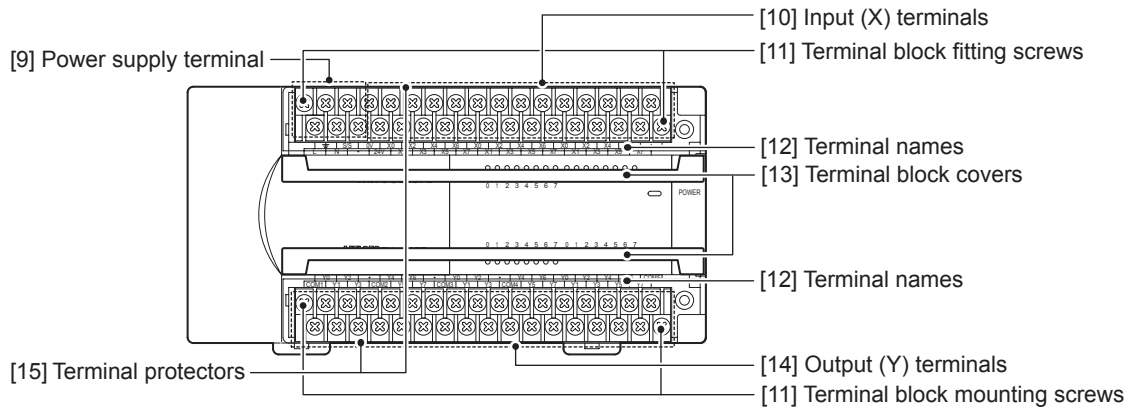

- [9] **Power supply terminal** Connect the power supply to the input/output powered extension unit at this terminal.
- [10] **Input (X) terminals** Wire switches and sensors to these terminals.
- [11] **Terminal block mounting screws** If the input/output powered extension unit must be replaced, loosen these screws to remove the upper part of the terminal block.
 → **For anchoring the terminal block, refer to Subsection 9.1.2.**
- [12] **Terminal names** The signal names for the power supply, input terminals and output terminals are shown.
- [13] **Terminal block covers** Protects the upper and lower stages of the terminal block.
- [14] **Output (Y) terminals** Wire the intended loads (contactors, solenoid valves, etc.) to these terminals.
- [15] **Terminal protectors** A terminal protector (refer to the following drawing) is fitted to the lower stage of each terminal block to prevent fingers from touching terminals, thereby improving the safety.



2. Side

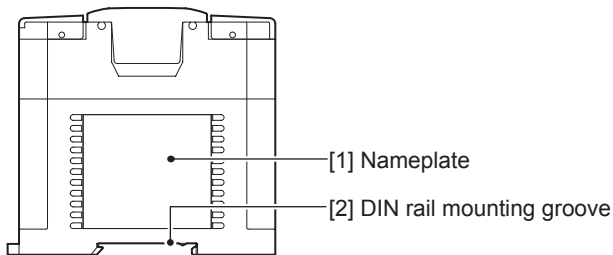

- [1] **Nameplate** The product model name, control number and power supply specifications are shown.
- [2] **DIN rail mounting groove** The unit can be installed on a 35 mm (1.38") wide DIN46277 rail.

15.3 FX2N-32ER-ES/UL, FX2N-48ER-ES/UL, FX2N-48ER-DS

15.3.1 Product specifications

The generic specifications are the same as those for the main unit.

→ For the generic specifications, refer to Section 4.1.

For external wiring, refer to the following chapters.

→ Refer to Chapter 9 for power supply wiring.

→ Refer to Chapter 10 for input wiring.

→ Refer to Chapter 12 for output wiring.

1. Power supply specifications

→ For the power supply specifications, refer to Section 15.2.

2. Input specifications (for sink input [-common] and source input [+common])

Item	FX2N-32ER-ES/UL	FX2N-48ER-ES/UL, FX2N-48ER-DS
Number of input points	16 points	24 points
Connection type	Removable terminal block (M3 screw)	
Input form	sink/source	
Input signal voltage	24V DC \pm 10% ^{*1}	
Input signal current	5 mA/24V DC	
Input impedance	4.3 k Ω	
Input sensitivity current	Input ON current	3.5 mA or more/24V DC
	Input OFF current	1.5 mA or less
Input response time	About 10 ms	
Input signal form	No-voltage contact input Sink: NPN open collector transistor Source: PNP open collector transistor	
Input circuit insulation	Insulation with photocoupler	
Indication of input operation	LED on panel is lit when there is input.	

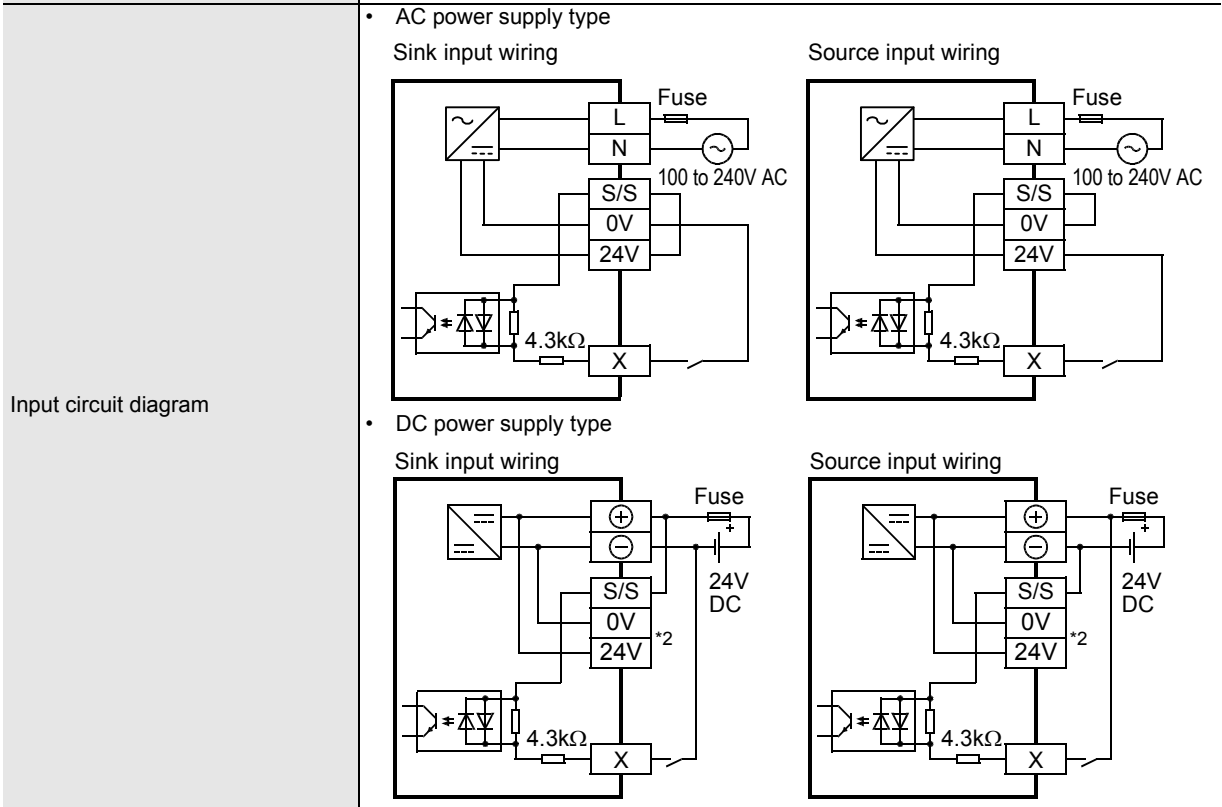

*1. The DC power type applies to the power supply voltage in "Power Supply Specifications (Power Supply Input/24V DC Service Power Supply)."

*2. Do not connect with 0V and 24V terminals.

3. Output specifications (relay output type)

Item		FX2N-32ER-ES/UL	FX2N-48ER-ES/UL, FX2N-48ER-DS
Number of output points		16 points	24 points
Connection type		Removable terminal block (M3 screw)	
Output unit		Relay	
External power supply		30V DC or less 240V AC or less (250V AC or less when the unit does not comply with CE, UL or cUL standards)	
Output circuit insulation		Mechanical insulation	
Indication of output operation		When power is applied to relay coil, LED is lit.	
Max. load	Resistance load	2A/point The total load current per common terminal should be the following value. • 4 output points/common terminal: 8 A or less	2A/point The total load current per common terminal should be the following value. • 4 output points/common terminal: 8 A or less • 8 output points/common terminal: 8 A or less
	Inductive load	80 VA → For the product life, refer to Subsection 4.4.2. → For cautions on external wiring, refer to Subsection 12.2.4.	
Open circuit leakage current		-	
Min. load		5V DC, 2 mA (reference value)	
Response time	OFF→ON	Approx. 10 ms	
	ON→OFF	Approx. 10 ms	
Output circuit diagram		<p>A number (1 or more) is entered in <input type="checkbox"/> of [COM <input type="checkbox"/>].</p>	

15.3.2 External dimensions

FX2N-32ER-ES/UL

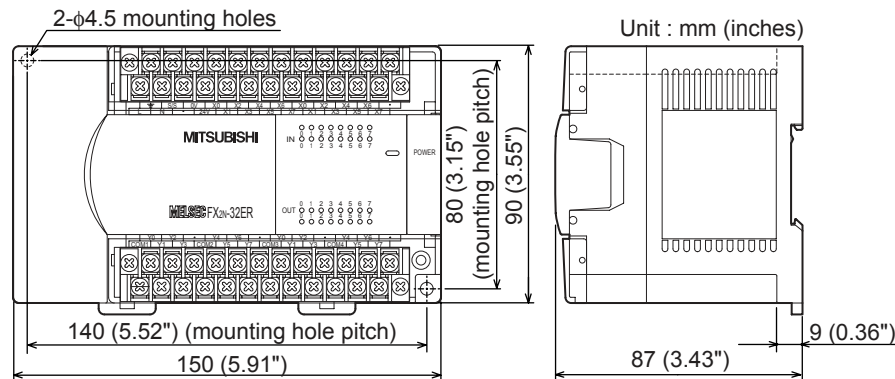

The terminal block uses M3 terminal screws.

FX2N-48ER-ES/UL, FX2N-48ER-DS

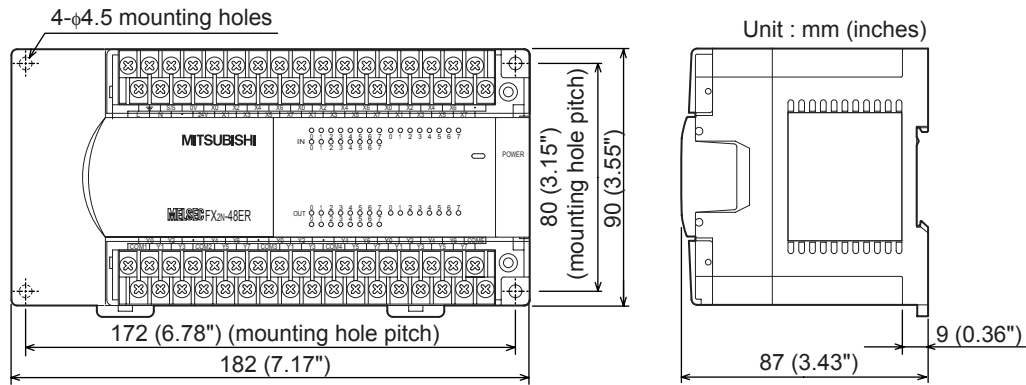

The terminal block uses M3 terminal screws.

15.3.3 Terminal layout

FX2N-32ER-ES/UL

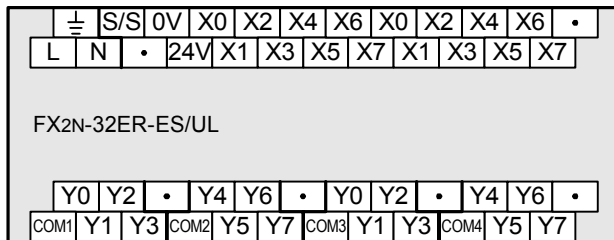

FX2N-48ER-ES/UL

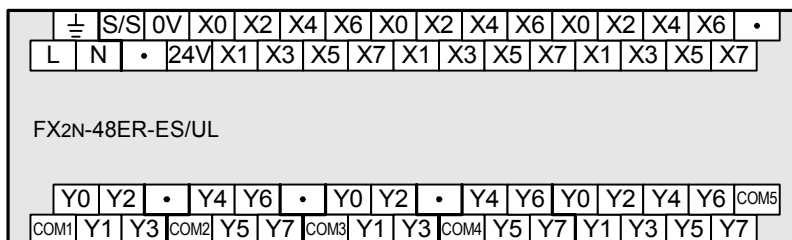

FX2N-48ER-DS

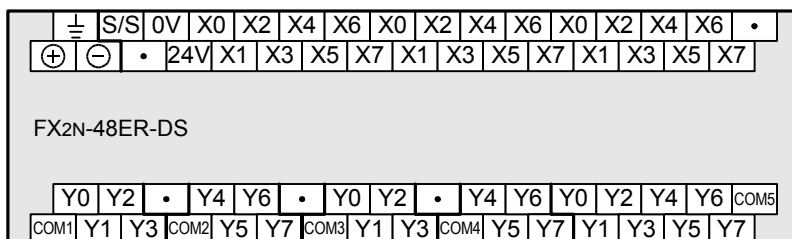

11 High-Speed Counters

12 Output Wiring

13 Wiring for Various Uses

14 Test Run, Maintenance, Troubleshooting

15 Input/Output Powered Extension Units

16 Input/Output Extension Blocks

17 Extension Power Supply Unit

18 Other Extension Units and Options

19 Display Module

20 Terminal Block

15.4 FX2N-32ET-ESS/UL, FX2N-48ET-ESS/UL, FX2N-48ET-DSS

15.4.1 Product specifications

The generic specifications are the same as those for the main unit.

→ For the generic specifications, refer to Section 4.1.

For external wiring, refer to the following chapters.

→ Refer to Chapter 9 for power supply wiring.

→ Refer to Chapter 10 for input wiring.

→ Refer to Chapter 12 for output wiring.

1. Power supply specifications

→ For the power supply specifications, refer to Section 15.2.

2. Input specifications (for sink input [-common] and source input [+common])

Item		FX2N-32ET-ESS/UL	FX2N-48ET-ESS/UL, FX2N-48ET-DSS
Number of input points		16 points	24 points
Connection type		Removable terminal block (M3 screw)	
Input form		sink/source	
Input signal voltage		24V DC \pm 10% ^{*1}	
Input signal current		5 mA/24V DC	
Input impedance		4.3 k Ω	
Input sensitivity current	Input ON current	3.5 mA or more/24V DC	
	Input OFF current	1.5 mA or less	
Input response time		About 10 ms	
Input signal form		No-voltage contact input Sink: NPN open collector transistor Source: PNP open collector transistor	
Input circuit insulation		Insulation with photocoupler	
Indication of input operation		LED on panel is lit when there is input.	

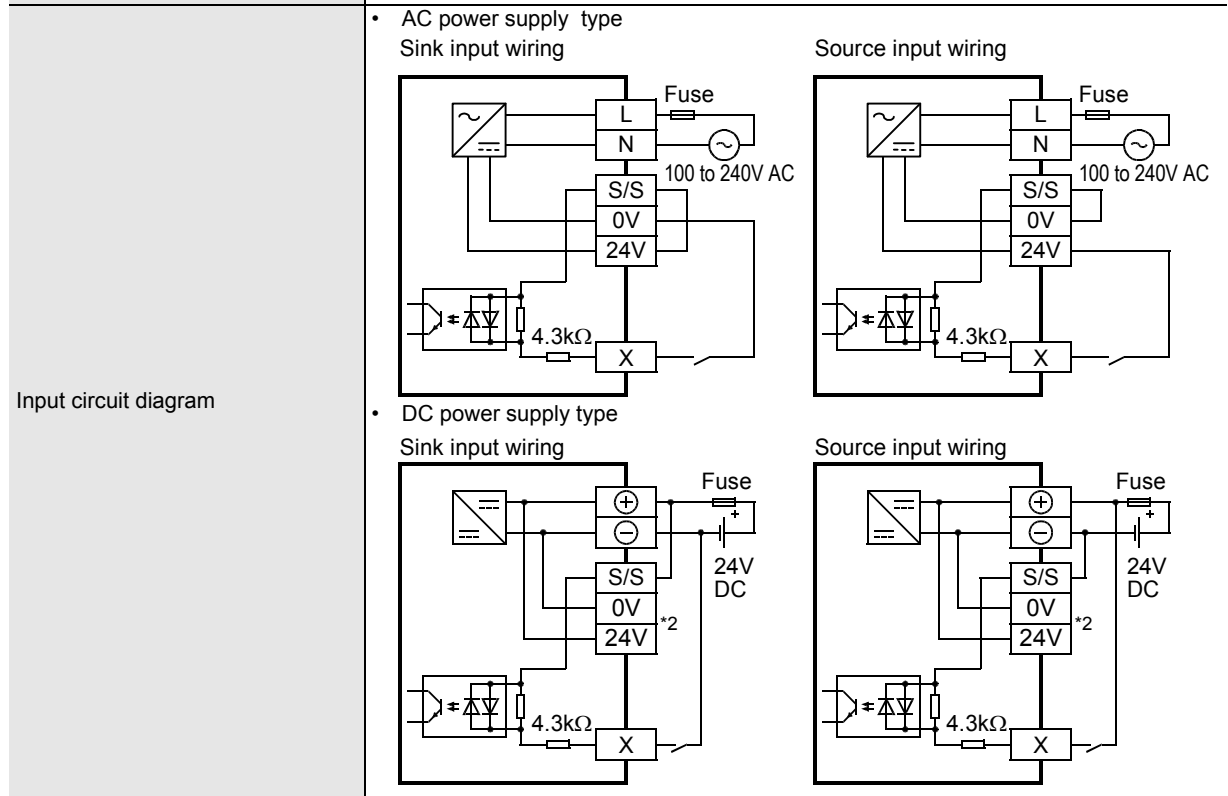

*1. The DC power type applies to the power supply voltage in "Power Supply Specifications (Power Supply Input/24V DC Service Power Supply)."

*2. Do not connect with 0V and 24V terminals.

3. Output specifications (transistor output type)

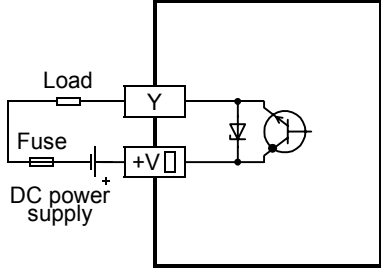
Item		FX2N-32ET-ESS/UL	FX2N-48ET-ESS/UL, FX2N-48ET-DSS
Number of output points		16 points	24 points
Connection type		Removable terminal block (M3 screw)	
Output unit/type		Transistor/source output	
External power supply		5 to 30V DC	
Output circuit insulation		Insulation with photocoupler	
Indication of output operation		When photocoupler is driven, LED on panel is lit.	
Max. load	Resistance load	0.5A/point The total load current per common terminal should be the following value. • 4 output points/common terminal: 0.8 A or less	0.5A/point The total load current per common terminal should be the following value. • 4 output points/common terminal: 0.8 A or less • 8 output points/common terminal: 1.6 A or less
	Inductive load	12 W/24V DC	
Open circuit leakage current		0.1 mA/30V DC	
Min. load		-	
Response time	OFF→ON	0.2 ms or less/200 mA (at 24V DC)	
	ON→OFF	0.2 ms or less/200 mA (at 24V DC)	
Output circuit diagram		 <p>A common number applies to the □ of [+V □].</p>	

15.4.2 External dimensions

FX2N-32ET-ESS/UL

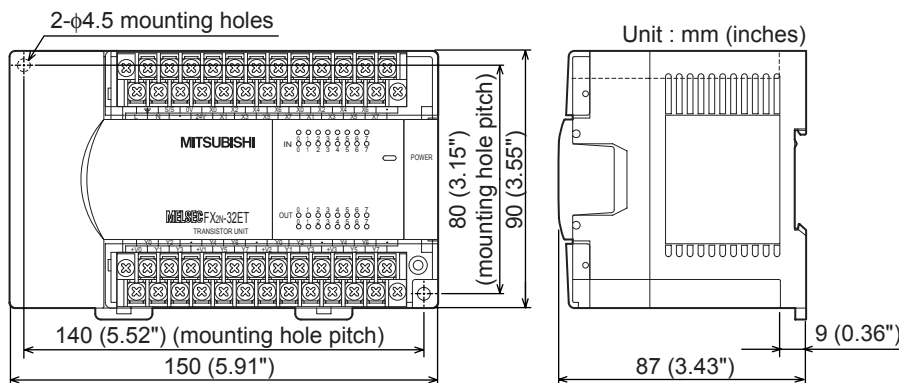

The terminal block uses M3 terminal screws.

11	High-Speed Counters
12	Output Wiring
13	Wiring for Various Uses
14	Test Run, Maintenance, Troubleshooting
15	Input/Output Powered Extension Units
16	Input/Output Extension Blocks
17	Extension Power Supply Unit
18	Other Extension Units and Options
19	Display Module
20	Terminal Block

FX2N-48ET-ESS/UL, FX2N-48ET-DSS

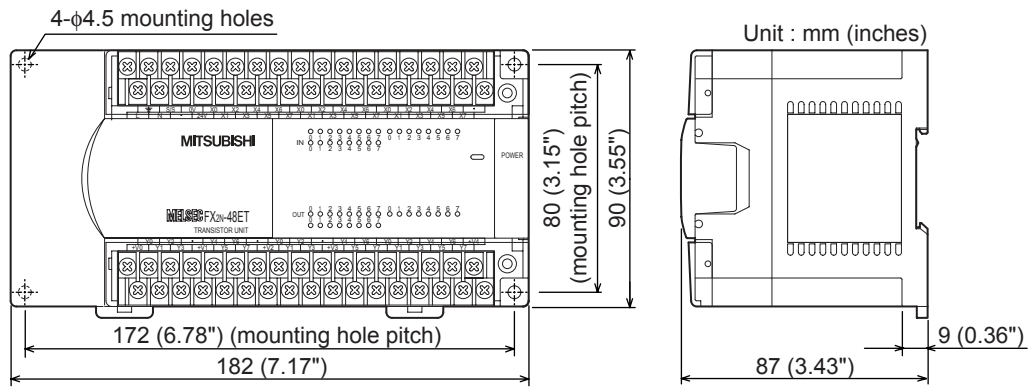

The terminal block uses M3 terminal screws.

15.4.3 Terminal layout

FX2N-32ET-ESS/UL

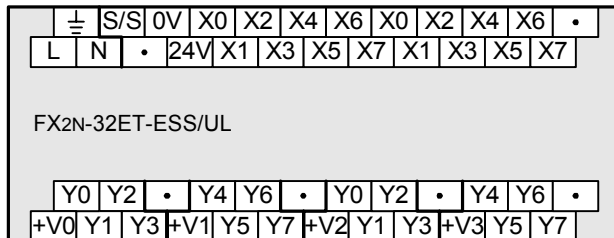

FX2N-48ET-ESS/UL

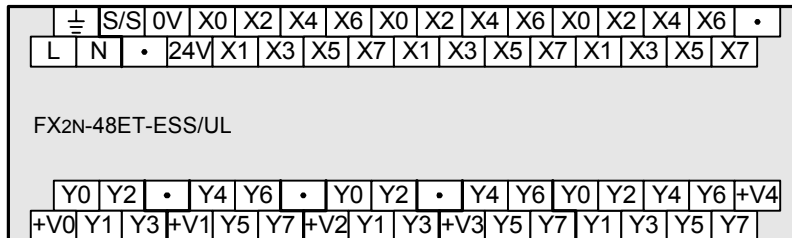

FX2N-48ET-DSS

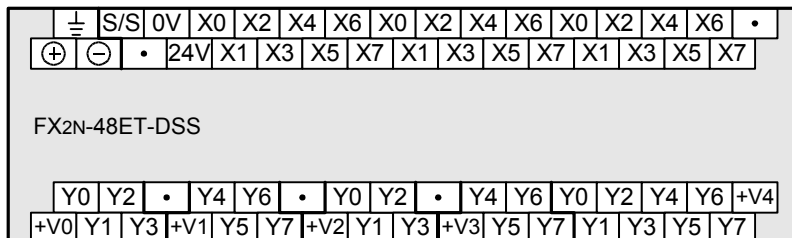

15.5 FX2N-32ER, FX2N-48ER, FX2N-48ER-D

15.5.1 Product specifications

The generic specifications are the same as those for the main unit.

→ For the generic specifications, refer to Section 4.1.

For external wiring, refer to the following chapters.

→ Refer to Chapter 9 for power supply wiring.

→ Refer to Chapter 10 for input wiring.

→ Refer to Chapter 12 for output wiring.

1. Power supply specifications

→ For the power supply specifications, refer to Section 15.2.

2. Input specifications (sink input [-common])

Item		FX2N-32ER	FX2N-48ER, FX2N-48ER-D
Number of input points		16 points	24 points
Connection type		Removable terminal block (M3 screw)	
Input form		Sink	
Input signal voltage		24V DC ± 10%*1	
Input signal current		5 mA/24V DC	
Input impedance		4.3 kΩ	
Input sensitivity current	Input ON current	3.5 mA or more/24V DC	
	Input OFF current	1.5 mA or less	
Input response time		About 10 ms	
Input signal form		No-voltage contact input or NPN open collector transistor	
Input circuit insulation		Insulation with photocoupler	
Indication of input operation		LED on panel is lit when there is input.	

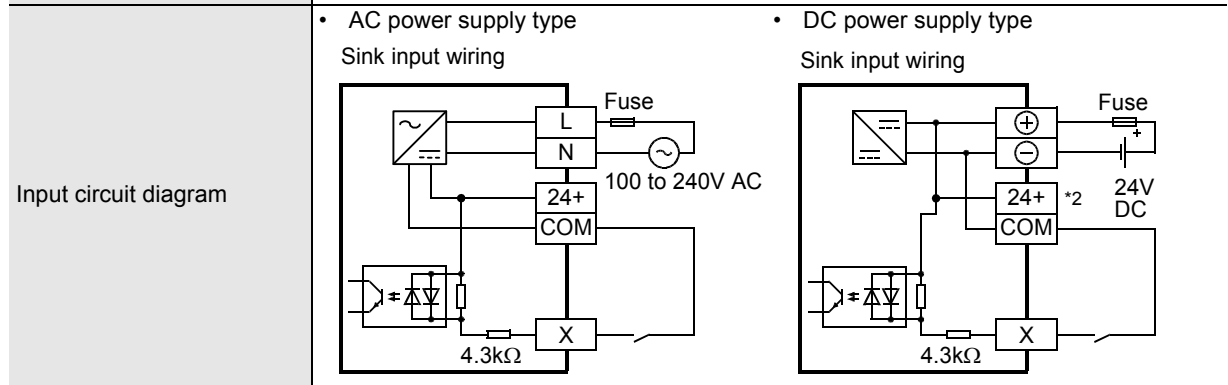

*1. The DC power type applies to the power supply voltage in "Power Supply Specifications (Power Supply Input/24V DC Service Power Supply)."

*2. Do not connect with 24+ terminals.

3. Output specifications (relay output type)

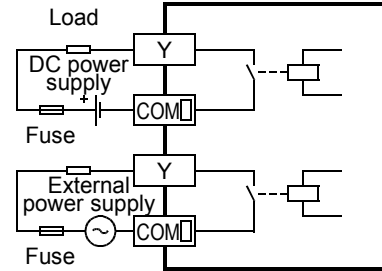
Item		FX2N-32ER	FX2N-48ER, FX2N-48ER-D
Number of output points		16 points	24 points
Connection type		Removable terminal block (M3 screw)	
Output unit		Relay	
External power supply		250V AC/30V DC or less	
Output circuit insulation		Mechanical insulation	
Indication of output operation		When power is applied to relay coil, LED on panel is lit.	
Max. load	Resistance load	2 A/point The total load current per common terminal should be the following value. • 4 output points/common terminal: 8 A or less	2 A/point The total load current per common terminal should be the following value. • 4 output points/common terminal: 8 A or less • 8 output points/common terminal: 8 A or less
	Inductive load	80 VA → For the product life, refer to Subsection 4.4.2. → For cautions on external wiring, refer to Subsection 12.2.4.	
Open circuit leakage current		-	
Min. load		5V DC, 2 mA (reference value)	
Response time	OFF→ON	Approx. 10 ms	
	ON→OFF	Approx. 10 ms	
Output circuit diagram		 <p>A common number applies to the □ of [COM □].</p>	

15.5.2 External dimensions

FX2N-32ER

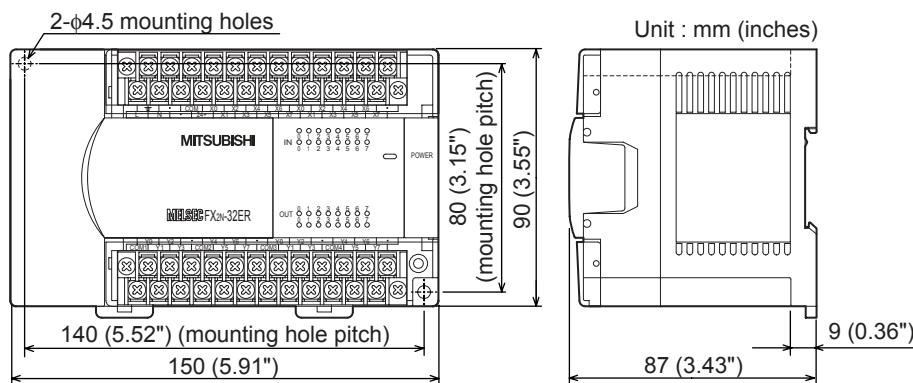

The terminal block uses M3 terminal screws.

FX2N-48ER, FX2N-48ER-D

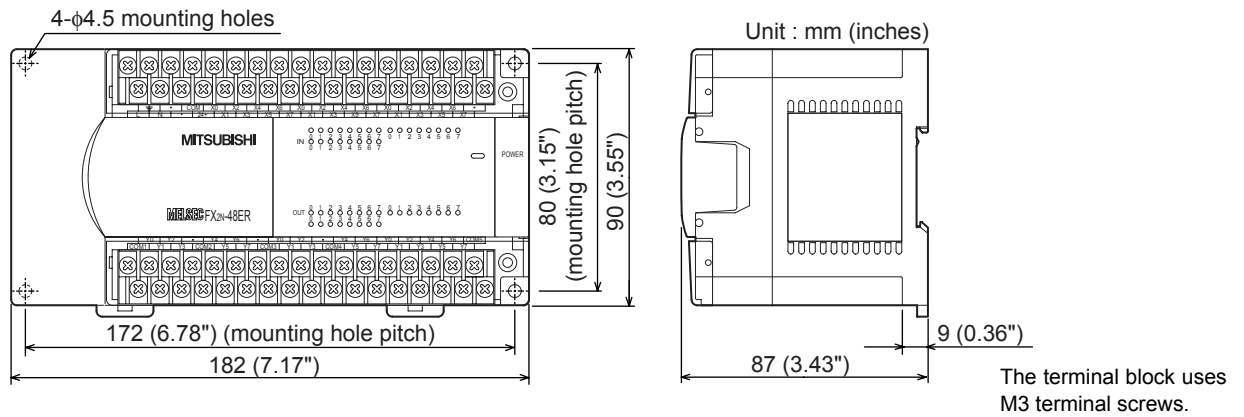

15.5.3 Terminal layout

FX2N-32ER

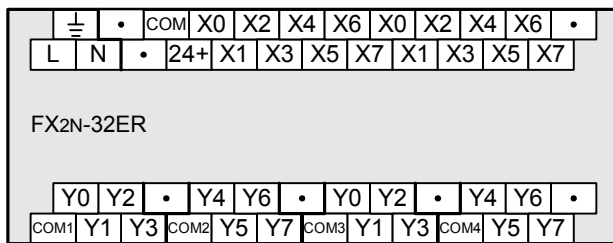

FX2N-48ER

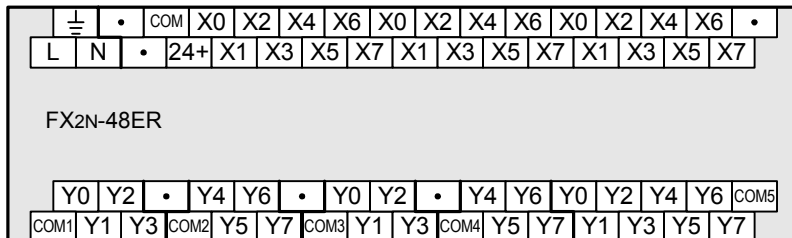

FX2N-48ER-D

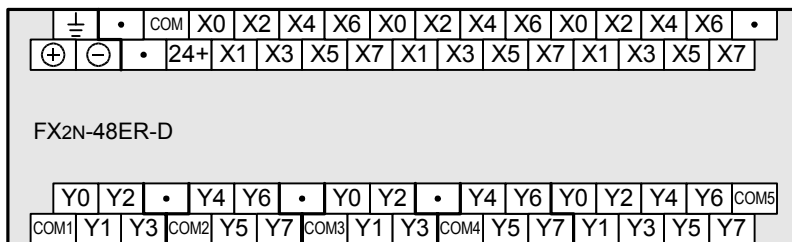

11	High-Speed Counters
12	Output Wiring
13	Wiring for Various Uses
14	Test Run, Maintenance, Troubleshooting
15	Input/Output Powered Extension Units
16	Input/Output Extension Blocks
17	Extension Power Supply Unit
18	Other Extension Units and Options
19	Display Module
20	Terminal Block

15.6 FX2N-32ET, FX2N-48ET, FX2N-48ET-D

15.6.1 Product specifications

The generic specifications are the same as those for the main unit.

→ For the generic specifications, refer to Section 4.1.

For external wiring, refer to the following chapters.

→ Refer to Chapter 9 for power supply wiring.

→ Refer to Chapter 10 for input wiring.

→ Refer to Chapter 12 for output wiring.

1. Power supply specifications

→ For the power supply specifications, refer to Section 15.2.

2. Input specifications (sink input [-common])

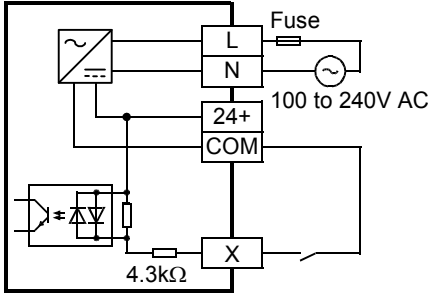
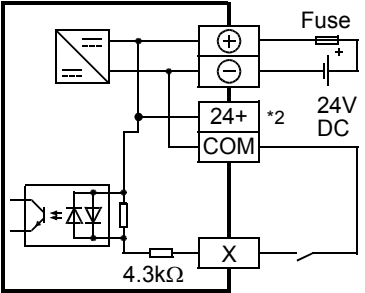
Item		FX2N-32ET	FX2N-48ET, FX2N-48ET-D
Number of input points		16 points	24 points
Connection type		Removable terminal block (M3 screw)	
Input form		Sink	
Input signal voltage		24V DC \pm 10%*1	
Input signal current		5 mA/24V DC	
Input impedance		4.3 k Ω	
Input sensitivity current	Input ON current	3.5 mA or more/24V DC	
	Input OFF current	1.5 mA or less	
Input response time		About 10 ms	
Input signal form		No-voltage contact input or NPN open collector transistor	
Input circuit insulation		Insulation with photocoupler	
Indication of input operation		LED on panel is lit when there is input.	
Input circuit diagram		<ul style="list-style-type: none"> AC power supply type Sink input wiring 	<ul style="list-style-type: none"> DC power supply type Sink input wiring 

*1. The DC power type applies to the power supply voltage in "Power Supply Specifications (Power Supply Input/24V DC Service Power Supply)."

*2. Do not connect with 24+ terminal.

3. Output specifications (transistor output type)

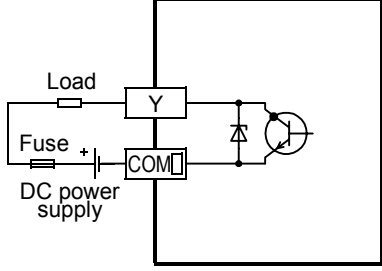
Item		FX2N-32ET	FX2N-48ET, FX2N-48ET-D
Number of output points		16 points	24 points
Connection type		Removable terminal block (M3 screw)	
Output unit/type		Transistor/sink output	
External power supply		5 to 30V DC	
Output circuit insulation		Insulation with photocoupler	
Indication of output operation		When photocoupler is driven, LED on panel is lit.	
Max. load	Resistance load	0.5A/point The total load current per common terminal should be the following value. • 4 output points/common terminal: 0.8 A or less	0.5A/point The total load current per common terminal should be the following value. • 4 output points/common terminal: 0.8 A or less • 8 output points/common terminal: 1.6 A or less
	Inductive load	12 W/24V DC	
Open circuit leakage current		0.1 mA or less/30V DC	
Min. load		-	
Response time	OFF→ON	0.2 ms or less/200 mA (at 24V DC)	
	ON→OFF	0.2 ms or less/200 mA (at 24V DC)	
Output circuit diagram		 <p>A common number applies to the □ of [COM □].</p>	

15.6.2 External dimensions

FX2N-32ET

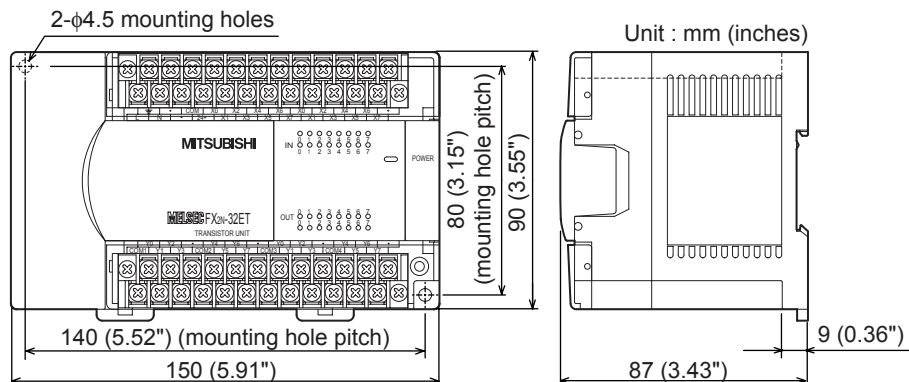

The terminal block uses M3 terminal screws.

11	High-Speed Counters
12	Output Wiring
13	Wiring for Various Uses
14	Test Run, Maintenance, Troubleshooting
15	Input/Output Powered Extension Units
16	Input/Output Extension Blocks
17	Extension Power Supply Unit
18	Other Extension Units and Options
19	Display Module
20	Terminal Block

FX2N-48ET, FX2N-48ET-D

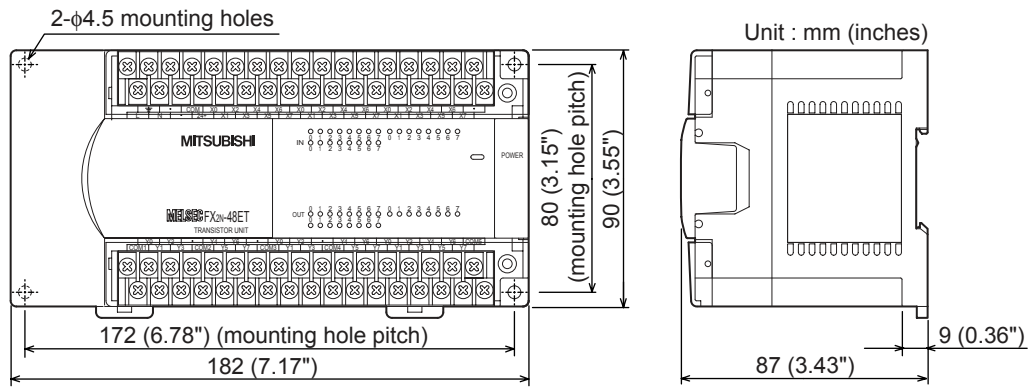

The terminal block uses M3 terminal screws.

15.6.3 Terminal layout

FX2N-32ET

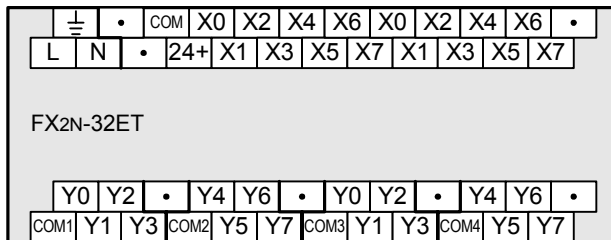

FX2N-48ET

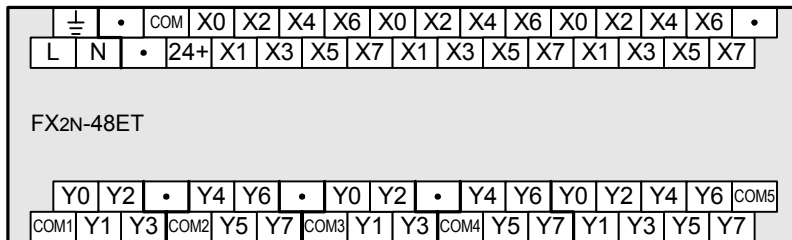

FX2N-48ET-D

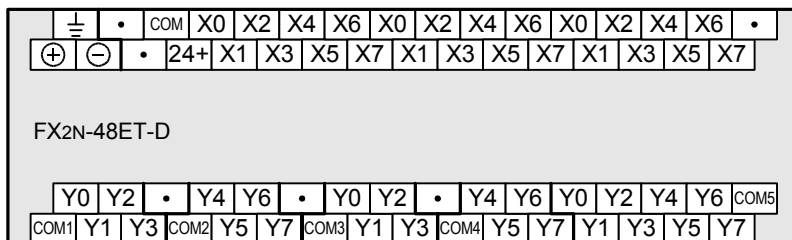

15.7 FX2N-32ES

15.7.1 Product specifications

The generic specifications are the same as those for the main unit.

→ For the generic specifications, refer to Section 4.1.

For external wiring, refer to the following chapters.

→ Refer to Chapter 9 for power supply wiring.

→ Refer to Chapter 10 for input wiring.

→ Refer to Chapter 12 for output wiring.

1. Power supply specifications

→ For the power supply specifications, refer to Section 15.2.

2. Input specifications (sink input [-common])

Item		FX2N-32ES
Number of input points		16 points
Connection type		Removable terminal block (M3 screw)
Input form		Sink
Input signal voltage		24V DC \pm 10%
Input signal current		5 mA/24V DC
Input impedance		4.3 k Ω
Input sensitivity current	Input ON current	3.5 mA or more/24V DC
	Input OFF current	1.5 mA or less
Input response time		About 10 ms
Input signal form		No-voltage contact input or NPN open collector transistor
Input circuit insulation		Insulation with photocoupler
Indication of input operation		LED on panel is lit when there is input.
Input circuit diagram		<p>Sink input wiring</p>

3. Output specifications (triac output type)

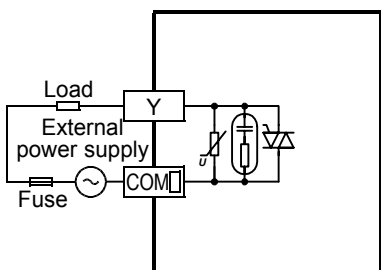
Item		FX2N-32ES
Number of output points		16 points
Connection type		Removable terminal block (M3 screw)
Output unit		Triac output (SSR)
External power supply		85 to 242V AC
Output circuit insulation		Insulation with photo-thyristor
Indication of output operation		When photo-thyristor is driven, LED on panel is lit.
Max. load	Resistance load	0.3A/point The total load current per common terminal should be the following value. • 4 output points/common terminal: 0.8 A or less
	Inductive load	15 VA/100V AC, 30 VA/200V AC
Open circuit leakage current		1 mA/100V AC, 2 mA/200V AC
Min. load		0.4 VA/100V AC, 1.6 VA/200V AC
Response time	OFF→ON	1 ms or less
	ON→OFF	10 ms or less
Output circuit diagram		 <p>A common number applies to the □ of [COM□].</p>

15.7.2 External dimensions

FX2N-32ES

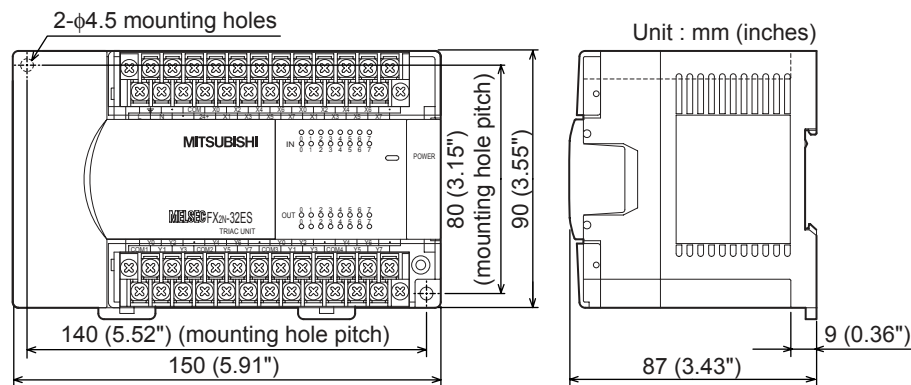

The terminal block uses M3 terminal screws.

15.7.3 Terminal layout

FX2N-32ES

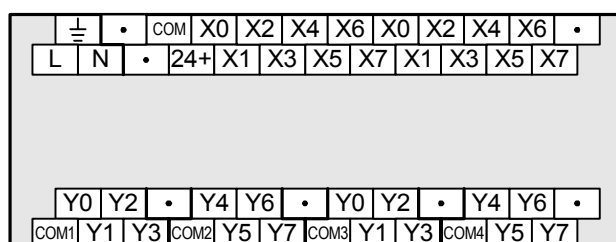

15.8 FX2N-48ER-UA1/UL

15.8.1 Product specifications

The generic specifications are the same as those for the main unit.

→ For the generic specifications, refer to Section 4.1.

For external wiring, refer to the following chapters.

→ Refer to Chapter 9 for power supply wiring.

→ Refer to Chapter 10 for input wiring.

→ Refer to Chapter 12 for output wiring.

1. Power supply specifications

→ For the power supply specifications, refer to Section 15.2.

2. Input specifications (100V AC Input)

Item		FX2N-48ER-UA1/UL
Number of input points		24 points
Connection type		Removable terminal block (M3 screw)
Input form		AC input
Input signal voltage		100 to 120V AC +10%,-15% 50/60 Hz
Input signal current		4.7 mA/100V AC 50 Hz (70% or less when turned on simultaneously) 6.2 mA/110V AC 60 Hz (70% or less when turned on simultaneously)
Input impedance		Approx. 21 kΩ/50 Hz Approx. 18 kΩ/60 Hz
Input sensitivity current	Input ON current	3.8 mA or more/80V AC
	Input OFF current	1.7 mA or less/30V AC
Input response time		Approx. 25 to 30 ms
Input signal form		Contact input
Input circuit insulation		Photocoupler insulation
Indication of input operation		LED on panel is lit when there is input.
Input circuit diagram		<p>*1 Input impedance</p>

3. Output specifications (relay output type)

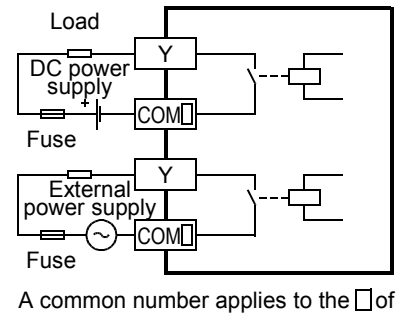
Item		FX2N-48ER-UA1/UL
Number of output points		24 points
Connection type		Removable terminal block (M3 screw)
Output unit		Relay
External power supply		30V DC or less 240V AC or less (250V AC or less when the unit does not comply with CE, UL or cUL standards)
Output circuit insulation		Mechanical insulation
Indication of output operation		When power is applied to relay coil, LED on panel lights.
Max. load	Resistance load	2A/point The total load current of resistance loads per common terminal should be the following value. <ul style="list-style-type: none"> 4 output points/common terminal: 8 A or less 8 output points/common terminal: 8 A or less
	Inductive load	80 VA → For the product life, refer to Subsection 4.4.2. → For cautions on external wiring, refer to Subsection 12.2.4.
Open circuit leakage current		-
Min. load		5V DC, 2 mA (reference value)
Response time	OFF→ON	Approx. 10 ms
	ON→OFF	Approx. 10 ms
Output circuit diagram		 <p>A common number applies to the [] of [COM].</p>

15.8.2 External dimensions

FX2N-48ER-UA1/UL

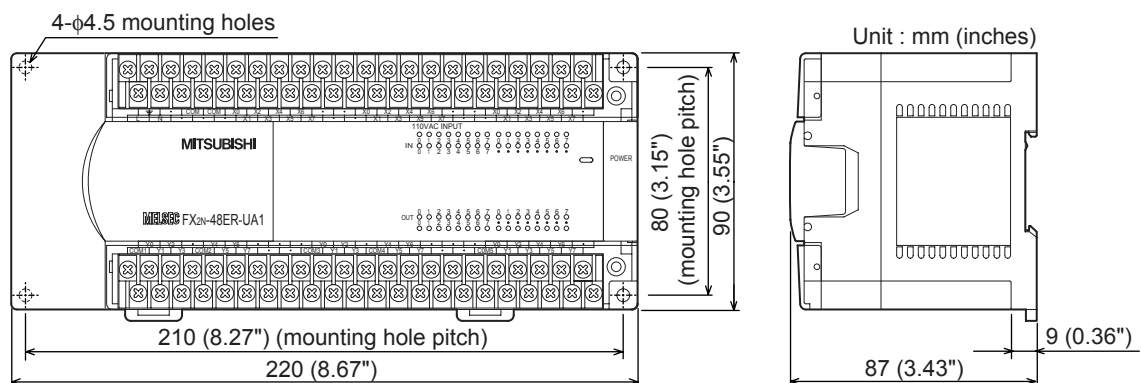

The terminal block uses M3 terminal screws.

15.8.3 Terminal layout

FX2N-48ER-UA1/UL

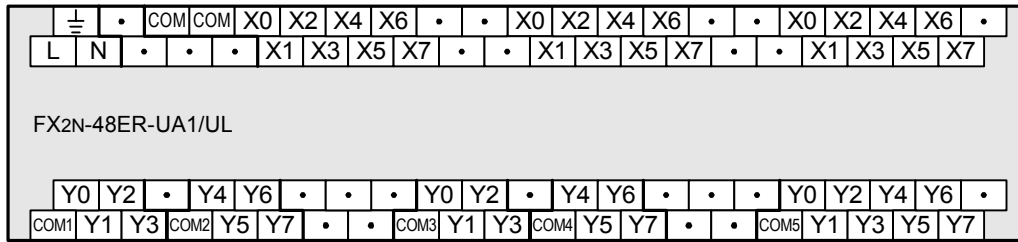

- 11** High-Speed Counters
- 12** Output Wiring
- 13** Wiring for Various Uses
- 14** Test Run, Maintenance, Troubleshooting
- 15** Input/Output Powered Extension Units
- 16** Input/Output Extension Blocks
- 17** Extension Power Supply Unit
- 18** Other Extension Units and Options
- 19** Display Module
- 20** Terminal Block

16. FX2N-8/16E*-(Input/Output Extension Blocks)

DESIGN PRECAUTIONS



DANGER

- Make sure to have the following safety circuits outside of the PLC to ensure safe system operation even during external power supply problems or PLC failure.
Otherwise, malfunctions may cause serious accidents.
 - 1) Most importantly, have the following: an emergency stop circuit, a protection circuit, an interlock circuit for opposite movements (such as normal vs. reverse rotation), and an interlock circuit (to prevent damage to the equipment at the upper and lower positioning limits).
 - 2) Note that when the PLC CPU detects an error, such as a watchdog timer error, during self-diagnosis, all outputs are turned off. Also, when an error that cannot be detected by the PLC CPU occurs in an input/output control block, output control may be disabled.
External circuits and mechanisms should be designed to ensure safe machinery operation in such a case.
 - 3) Note that the output current of the 24V DC service power supply varies depending on the model and the absence/presence of extension blocks. If an overload occurs, the voltage automatically drops, inputs in the PLC are disabled, and all outputs are turned off.
External circuits and mechanisms should be designed to ensure safe machinery operation in such a case.
 - 4) Note that when an error occurs in a relay, triac or transistor output device, the output could be held either on or off.
For output signals that may lead to serious accidents, external circuits and mechanisms should be designed to ensure safe machinery operation in such a case.

DESIGN PRECAUTIONS



CAUTION

- Do not bundle the control line together with or lay it close to the main circuit or power line. As a guideline, lay the control line at least 100mm (3.94") or more away from the main circuit or power line.
Noise may cause malfunctions.

WIRING PRECAUTIONS



DANGER

- Make sure to cut off all phases of the power supply externally before attempting installation or wiring work.
Failure to do so may cause electric shock or damage to the product.
- Make sure to attach the terminal cover, offered as an accessory, before turning on the power or initiating operation after installation or wiring work.
Failure to do so may cause electric shock.

WIRING PRECAUTIONS



CAUTION

- Connect the AC power supply wiring to the dedicated terminals described in this manual.
If an AC power supply is connected to a DC input/output terminal or DC power supply terminal, the PLC will burn out.
- Connect the DC power supply wiring to the dedicated terminals described in this manual.
If an AC power supply is connected to a DC input/output terminal or DC power supply terminal, the PLC will burn out.
- Do not wire vacant terminals externally.
Doing so may damage the product.
- When drilling screw holes or wiring, make sure that cutting and wiring debris do not enter the ventilation slits.
Failure to do so may cause fire, equipment failures or malfunctions.
- Make sure to properly wire the FX3U Series main unit and FX0N/FX2N/FX3U Series extension equipment in accordance with the following precautions.
Failure to do so may cause electric shock, equipment failures, a short-circuit, wire breakage, malfunctions, or damage to the product.
 - The disposal size of the cable end should follow the dimensions described in the manual.
 - Tightening torque should follow the specifications in the manual.

16.1 Outline

Connect input/output extension blocks to the PLC to add more input/output points. 8 or 16 points can be added by an input/output extension block.

Since the power is supplied from the main unit, it is not necessary to prepare another power supply unit for each input/output extension block.

16.1.1 Product type

There are various types of input/output extension blocks. Select optimum blocks considering the input type, output type, and connection unit of your system.

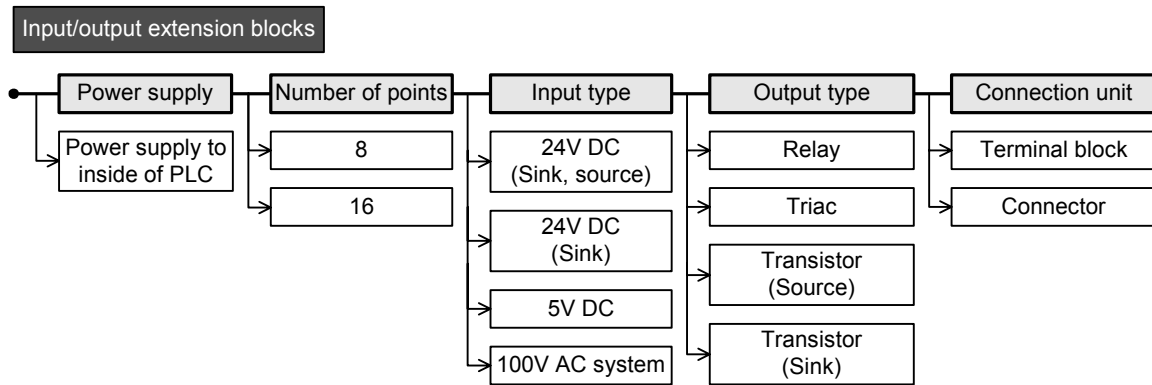

- 11** High-Speed Counters
- 12** Output Wiring
- 13** Wiring for Various Uses
- 14** Test Run, Maintenance, Troubleshooting
- 15** Input/Output Powered Extension Units
- 16** Input/Output Extension Blocks
- 17** Extension Power Supply Unit
- 18** Other Extension Units and Options
- 19** Display Module
- 20** Terminal Block

16.1.2 List of products

1. For input/output extension

Sink :Sink [-common], **Source** :Source [+common]

Model	Input			Output			Connection unit
	Type	Number of points	Common system	Type	Number of points	Common system	
Common to both sink and source inputs							
FX2N-8ER-ES/UL	24V DC	4(8)*1	Sink Source	Relay	4(8)*1	-	Terminal block
Dedicated to sink input only							
FX2N-8ER	24V DC	4(8)*1	Sink	Relay	4(8)*1	-	Terminal block

*1. Four inputs and four outputs are occupied as unused numbers.

2. For input extension

Sink :Sink [-common], **Source** :Source [+common]

Model	Input			Output			Connection unit
	Type	Number of points	Common system	Type	Number of points	Common system	
Common to both sink and source inputs							
FX2N-8EX-ES/UL	24V DC	8	Sink Source	-	-	-	Terminal block
FX2N-16EX-ES/UL	24V DC	16	Sink Source	-	-	-	Terminal block
Dedicated to sink input only							
FX2N-8EX	24V DC	8	Sink	-	-	-	Terminal block
FX2N-16EX	24V DC	16	Sink	-	-	-	Terminal block
FX2N-16EX-C	24V DC	16	Sink	-	-	-	Connector
FX2N-16EXL-C	5V DC	16	Sink	-	-	-	Connector
100V AC input type							
FX2N-8EX-UA1/UL	100V AC	8	-	-	-	-	Terminal block

3. For output extension

Sink :Sink [-common], **Source** :Source [+common]

Model	Input			Output			Connection unit
	Type	Number of points	Common system	Type	Number of points	Common system	
Relay output type							
FX2N-8EYR-ES/UL	-	-	-	Relay	8	-	Terminal block
FX2N-8EYR-S-ES/UL	-	-	-	Relay	8	-	Terminal block
FX2N-8EYR	-	-	-	Relay	8	-	Terminal block
FX2N-16EYR-ES/UL	-	-	-	Relay	16	-	Terminal block
FX2N-16EYR	-	-	-	Relay	16	-	Terminal block
Dedicated to sink output only							
FX2N-8EYT	-	-	-	Transistor	8	Sink	Terminal block
FX2N-8EYT-H	-	-	-	Transistor	8	Sink	Terminal block
FX2N-16EYT	-	-	-	Transistor	16	Sink	Terminal block
FX2N-16EYT-C	-	-	-	Transistor	16	Sink	Connector
FX2N-16EYS	-	-	-	Triac(SSR)	16	-	Terminal block
Dedicated to source output only							
FX2N-8EYT-ESS/UL	-	-	-	Transistor	8	Source	Terminal block
FX2N-16EYT-ESS/UL	-	-	-	Transistor	16	Source	Terminal block

11 High-Speed Counters

12 Output Wiring

13 Wiring for Various Uses

14 Test Run, Maintenance, Troubleshooting

15 Input/Output Powered Extension Units

16 Input/Output Extension Blocks

17 Extension Power Supply Unit

18 Other Extension Units and Options

19 Display Module

20 Terminal Block

16.2 FX2N-8ER-ES/UL (24V DC Sink/Source Input, Relay Output)

16.2.1 Product specifications

The generic specifications are identical to the main unit specifications.

→ Refer to Section 4.1 for generic specifications.

For external wiring, refer to the following chapters.

→ Refer to Chapter 10 for input wiring.

→ Refer to Chapter 12 for output wiring.

1. Power supply specifications

Item	FX2N-8ER-ES/UL
Product type	FX2N extension block
Rated voltage	24V DC (supplied from main unit and input/output powered extension unit)

2. Weight and Other specifications

Item	FX2N-8ER-ES/UL
MASS (Weight)	0.2 kg (0.44lbs)
Other	<ul style="list-style-type: none"> The extension cable is already connected to the extension block. Accessories: Label for indication of input/output number The DIN46277 rail (width: 35 mm (1.38")) or direct installation.

3. Input specifications (common to both sink and source inputs)

Item	FX2N-8ER-ES/UL	
Input points	4 points	
Connection unit	Vertical terminal block (M3 screws) / For a detailed description of wiring, refer to the input line connection diagram of the main unit.	
Input type	sink/source	
Input signal voltage	24V DC \pm 10%	
Input signal current	5 mA/24V DC	
Input impedance	4.3k Ω	
Input sensitivity current	Input-ON current	3.5 mA or more at 24V DC
	Input-OFF current	1.5 mA or less
Input response time	Approx. 10 ms	
Input signal type	Sink input: No-voltage contact input, NPN open collector transistor Source input: No-voltage contact input, PNP open collector transistor	
Input circuit insulation	Photocoupler insulation	
Indication of input operation	LED on panel lights when input.	

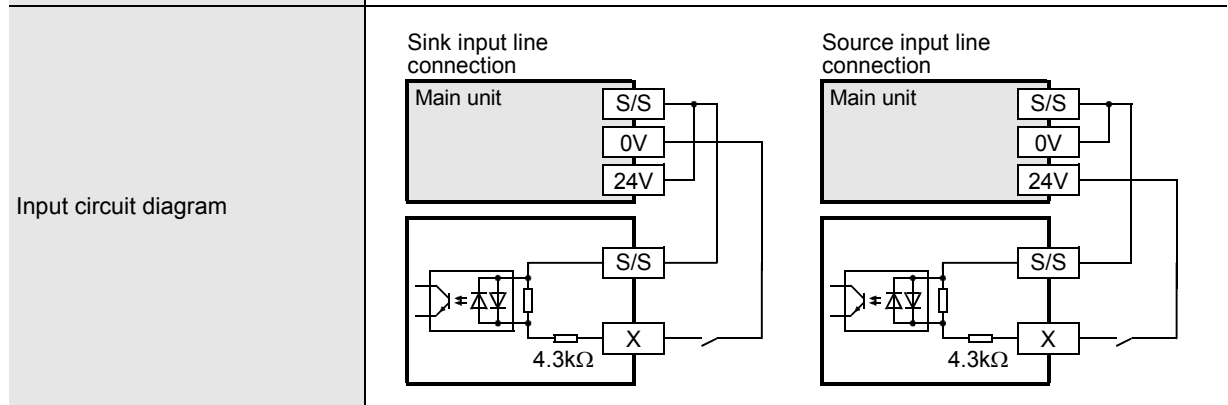

4. Output specifications (Relay output type)

Item		FX2N-8ER-ES/UL
Output points		4 points
Connection unit		Vertical terminal block (M3 screws)
Output unit		Relay
External power supply		5 to 30V DC 240V AC or less (250V AC or less when the unit does not comply with CE, UL, or cUL standards)
Output circuit insulation method		Mechanical insulation
Indication of output operation		Supplying power to the relay coil will light the LED indicator lamp on panel.
Maximum load	Resistance load	2 A/point The total resistance load current per common should be as follows: • 4 output points/common: 8A or less
	Inductive load	80 VA → For the product life, refer to Subsection 4.4.2. → For cautions on external wiring, refer to Subsection 12.2.4.
Open circuit leakage current		-
Minimum load		5V DC, 2 mA (reference values)
Response time	OFF→ON	Approx. 10 ms
	ON→OFF	Approx. 10 ms
Output circuit diagram		

16.2.2 Parts identification and terminal arrangement

Input numbers (X) are assigned to the upper four points, and output numbers (Y) are assigned to the lower four points.

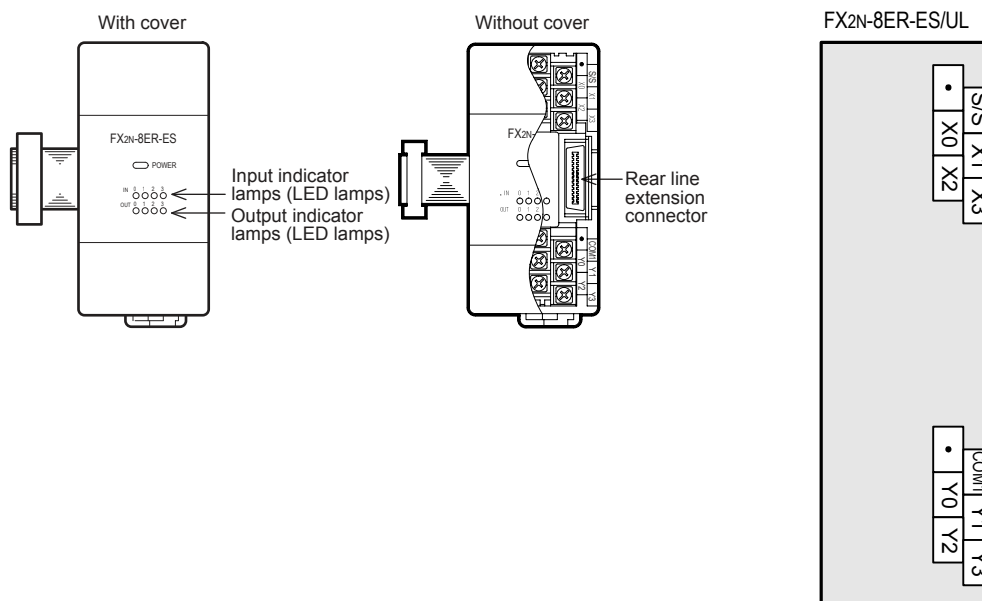

11	High-Speed Counters
12	Output Wiring
13	Wiring for Various Uses
14	Test Run, Maintenance, Troubleshooting
15	Input/Output Powered Extension Units
16	Input/Output Extension Blocks
17	Extension Power Supply Unit
18	Other Extension Units and Options
19	Display Module
20	Terminal Block

16.2.3 External dimensions

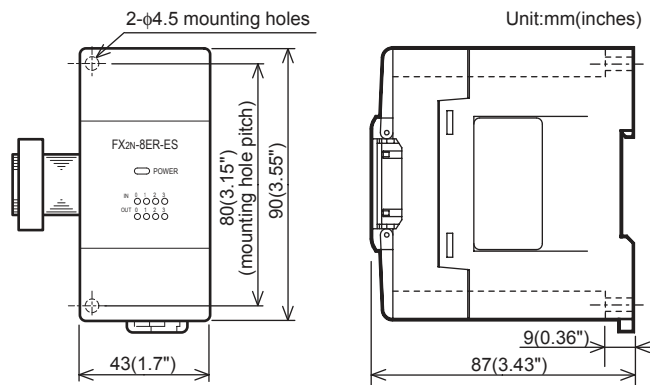

16.3 FX2N-8ER (24V DC Sink Input, Relay Output)

16.3.1 Product specifications

The generic specifications are identical to the main unit specifications.

→ Refer to Section 4.1 for generic specifications.

For external wiring, refer to the following chapters.

→ Refer to Chapter 10 for input wiring.

→ Refer to Chapter 12 for output wiring.

1. Power supply specifications

Item	FX2N-8ER
Product type	FX2N extension block
Rated voltage	24V DC (supplied from main unit and input/output powered extension unit)

2. Weight and Other specifications

Item	FX2N-8ER
MASS (Weight)	0.2 kg (0.44lbs)
Other	<ul style="list-style-type: none"> The extension cable is already connected to the extension block. Accessories: Label for indication of input/output number The DIN46277 rail (width: 35 mm (1.38")) or direct installation.

3. Input specifications

Item	FX2N-8ER	
Input points	4 points	
Connection unit	Vertical terminal block (M3 screws) / For a detailed description of wiring, refer to the input line connection diagram of the main unit.	
Input type	Sink	
Input signal voltage	24V DC \pm 10%	
Input signal current	5 mA/24V DC	
Input impedance	4.3k Ω	
Input sensitivity current	Input-ON current	3.5 mA or more at 24V DC
	Input-OFF current	1.5 mA or less
Input response time	Approx. 10 ms	
Input signal type	No-voltage contact input NPN open collector transistor	
Input circuit insulation	Photo-coupler insulation	
Indication of input operation	LED on panel lights when input.	

Input circuit diagram

Sink input line connection

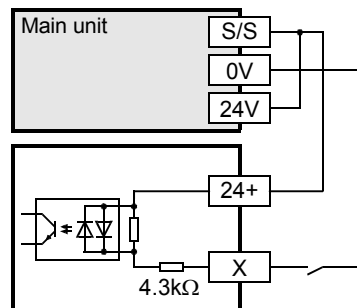

4. Output specifications (Relay output type)

Item		FX2N-8ER
Output points		4 points
Connection unit		Vertical terminal block (M3 screws)
Output unit		Relay
External power supply		250V AC 30V DC or less
Output circuit insulation method		Mechanical insulation
Indication of output operation		Supplying power to the relay coil will light the LED indicator lamp on panel.
Maximum load	Resistance load	2 A/point The total resistance load current per common should be as follows: • 4 output points/common: 8A or less
	Inductive load	80 VA → For the product life, refer to Subsection 4.4.2. → For cautions on external wiring, refer to Subsection 12.2.4.
Open circuit leakage current		-
Minimum load		5V DC, 2 mA (reference values)
Response time	OFF→ON	Approx. 10 ms
	ON→OFF	Approx. 10 ms
Output circuit diagram		

16.3.2 Parts identification and terminal arrangement

Input numbers (X) are assigned to the upper four points, and output numbers (Y) are assigned to the lower four points.

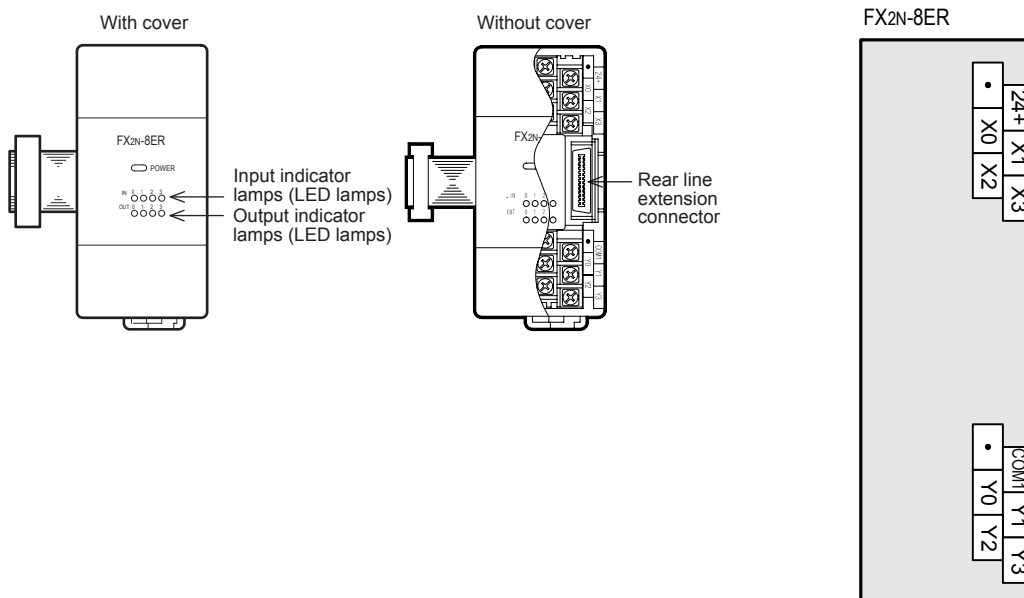

16.3.3 External dimensions

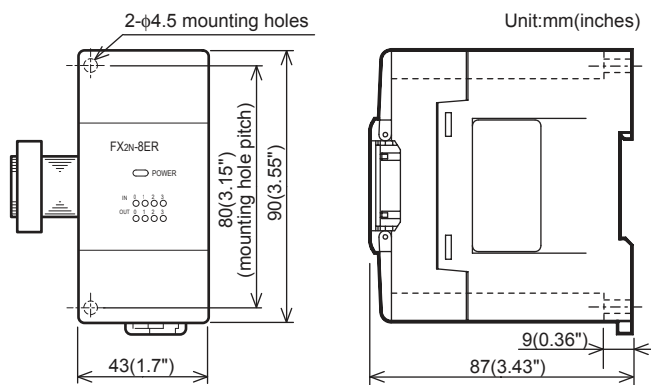

11	High-Speed Counters
12	Output Wiring
13	Wiring for Various Uses
14	Test Run, Maintenance, Troubleshooting
15	Input/Output Powered Extension Units
16	Input/Output Extension Blocks
17	Extension Power Supply Unit
18	Other Extension Units and Options
19	Display Module
20	Terminal Block

16.4 FX2N-8EX-ES/UL, FX2N-16EX-ES/UL (24V DC Sink/Source Input)

16.4.1 Product specifications

The generic specifications are identical to the main unit specifications.

→ Refer to Section 4.1 for generic specifications.

For external wiring, refer to the following chapter.

→ Refer to Chapter 10 for input wiring.

1. Power supply specifications

Item	FX2N-8EX-ES/UL	FX2N-16EX-ES/UL
Product type	FX2N extension block	
Rated voltage	24V DC (supplied from main unit and input/output powered extension unit)	

2. Weight and Other specifications

Item	FX2N-8EX-ES/UL	FX2N-16EX-ES/UL
MASS (Weight)	0.2 kg (0.44lbs)	0.3 kg (0.66lbs)
Other	<ul style="list-style-type: none"> The extension cable is already connected to the extension block. Accessories: Label for indication of input/output number The DIN46277 rail (width: 35 mm (1.38")) or direct installation. 	

3. Input specifications (common to both sink and source inputs)

Item	FX2N-8EX-ES/UL	FX2N-16EX-ES/UL
Input points	8 points	16 points
Connection unit	Vertical terminal block (M3 screws) / For a detailed description of wiring, refer to the input line connection diagram of the main unit.	
Input type	sink/source	
Input signal voltage	24V DC \pm 10%	
Input signal current	5 mA/24V DC	
Input impedance	4.3k Ω	
Input sensitivity current	Input-ON current	3.5 mA or more at 24V DC
	Input-OFF current	1.5 mA or less
Input response time	Approx. 10 ms	
Input signal type	Sink input: No-voltage contact input, NPN open collector transistor Source input: No-voltage contact input, PNP open collector transistor	
Input circuit insulation	Photocoupler insulation	
Indication of input operation	LED on panel lights when input.	

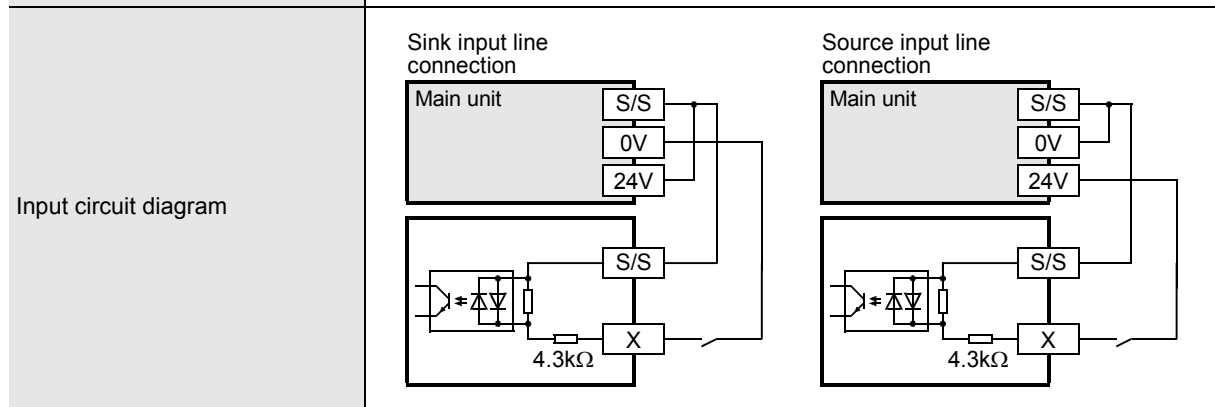

16.4.2 Parts identification and terminal arrangement

FX2N-8EX-ES/UL

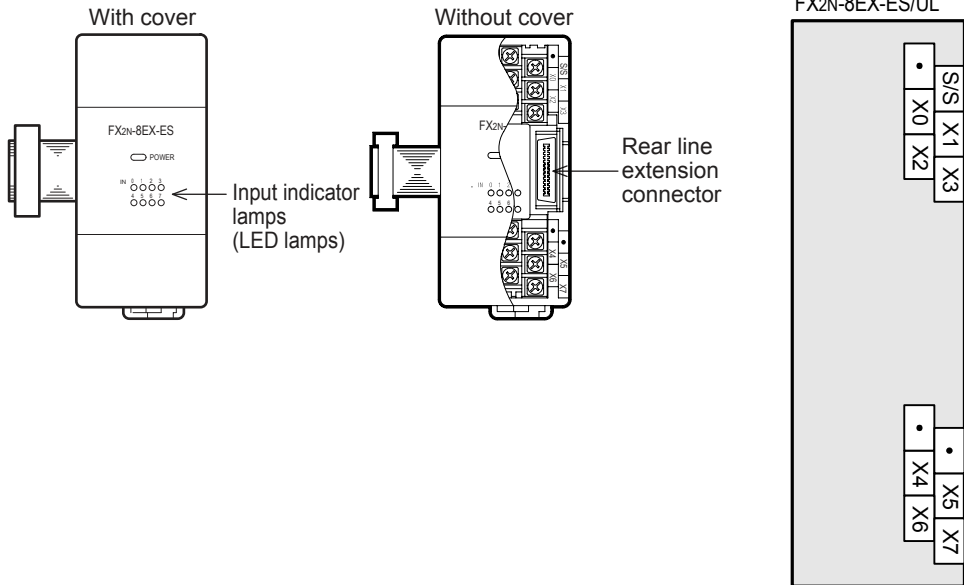

FX2N-16EX-ES/UL

When an input (X) number is assigned, 8 points on the upper side will be used for the lower input numbers, and 8 points on the lower side will be used for the higher input numbers.

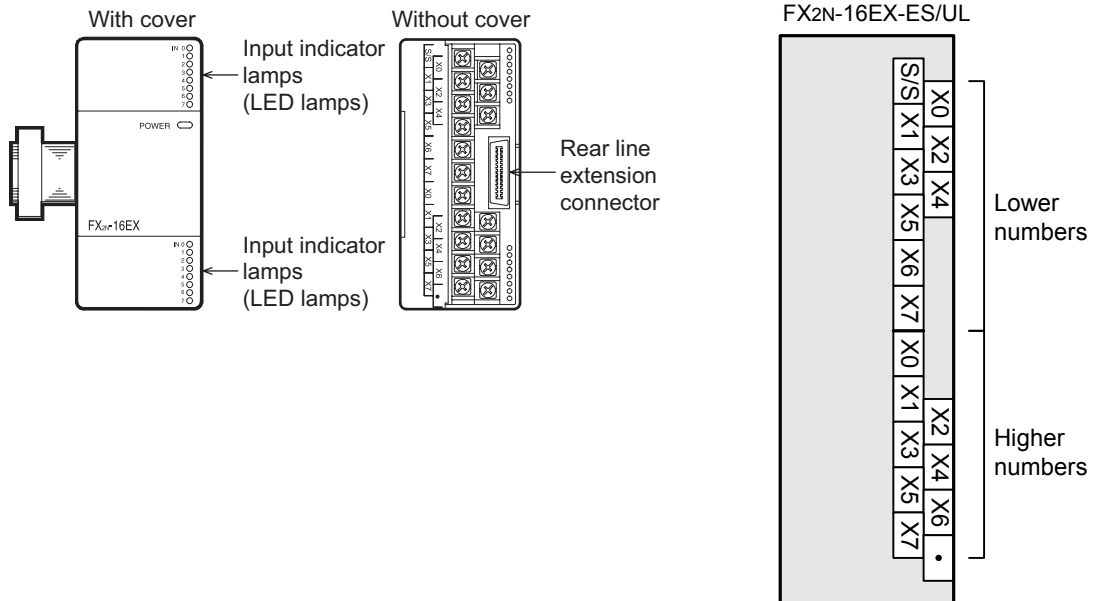

11 High-Speed Counters
 12 Output Wiring
 13 Wiring for Various Uses
 14 Test Run, Maintenance, Troubleshooting
 15 Input/Output Powered Extension Units
 16 Input/Output Extension Blocks
 17 Extension Power Supply Unit
 18 Other Extension Units and Options
 19 Display Module
 20 Terminal Block

16.4.3 External dimensions

FX2N-8EX-ES/UL

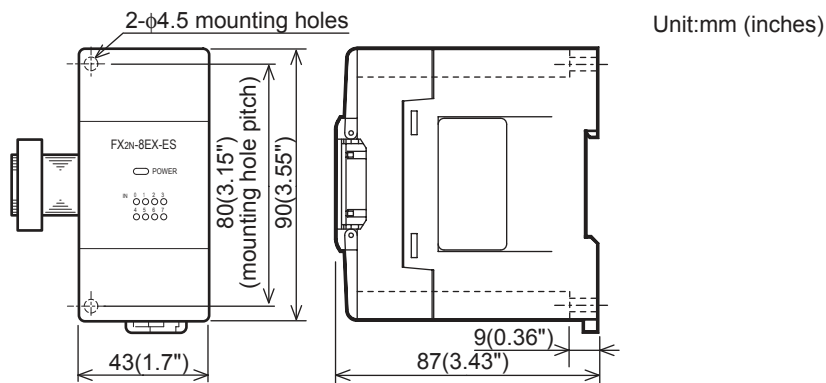

FX2N-16EX-ES/UL

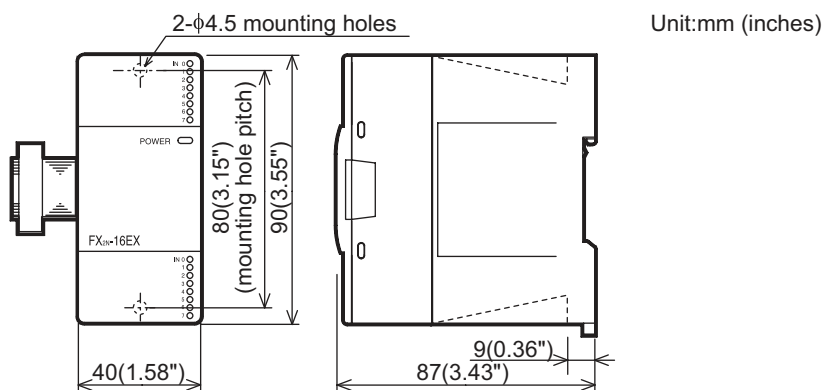

16.5 FX2N-8EX, FX2N-16EX and FX2N-16EX-C

16.5.1 Product specifications

The generic specifications are identical to the main unit specifications.

→ Refer to Section 4.1 for generic specifications.

For external wiring, refer to the following chapter.

→ Refer to Chapter 10 for input wiring.

1. Power supply specifications

Item	FX2N-8EX	FX2N-16EX	FX2N-16EX-C
Product type	FX2N extension block		FX2N connector type extension block
Rated voltage	24V DC (supplied from main unit and input/output powered extension unit)		

2. Weight and Other specifications

Item	FX2N-8EX	FX2N-16EX	FX2N-16EX-C
MASS (Weight)	0.2 kg (0.44lbs)	0.3 kg (0.66lbs)	
Other	<ul style="list-style-type: none"> The extension cable is already connected to the extension block. Accessories: Label for indication of input/output number The DIN46277 rail (width: 35 mm (1.38")) or direct installation. 		

3. Input specifications

Item	FX2N-8EX	FX2N-16EX	FX2N-16EX-C
Input points	8 points	16 points	
Connection unit	Vertical terminal block (M3 screws) / For a detailed description of wiring, refer to the input line connection diagram of the main unit.		Connector terminal block
Input type	Sink		
Input signal voltage	24V DC ± 10%		
Input signal current	5 mA/24V DC		
Input impedance	4.3kΩ		
Input sensitivity current	Input-ON current	3.5 mA or more at 24V DC	
	Input-OFF current	1.5 mA or less	
Input response time	Approx. 10 ms		
Input signal type	No-voltage contact input NPN open collector transistor		
Input circuit insulation	Photo-coupler insulation		
Indication of input operation	LED on panel lights when input.		
Input circuit diagram	<p>Sink input line connection</p>		

16.5.2 Parts identification and terminal arrangement

FX2N-8EX

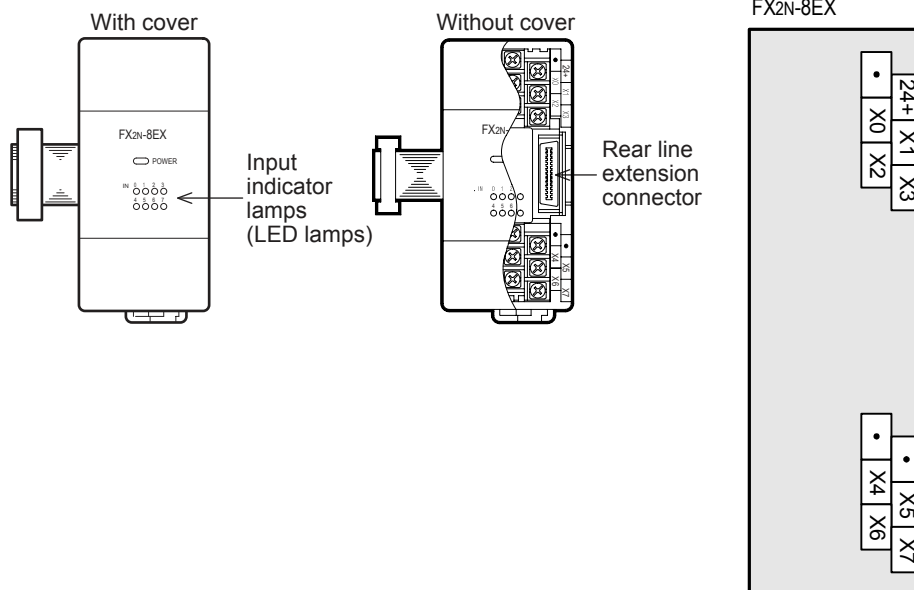

FX2N-16EX

When an input (X) number is assigned, 8 points on the upper side will be used for the lower input numbers, and 8 points on the lower side will be used for the higher input numbers.

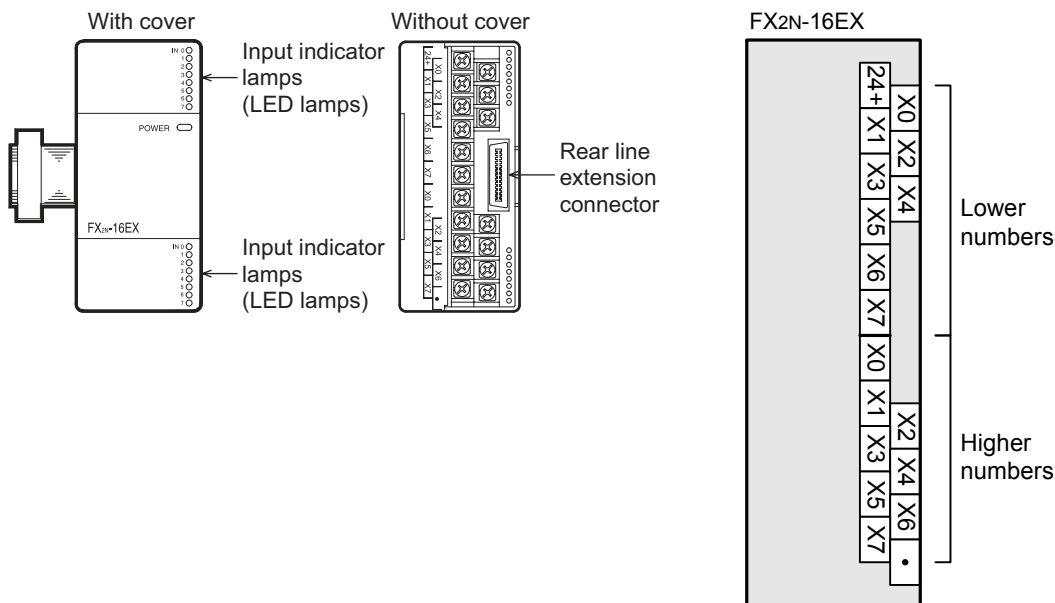

FX2N-16EX-C

When an input (X) number is assigned, 8 points on side A will be used for the lower input numbers, and 8 points on side B will be used for the higher input numbers.

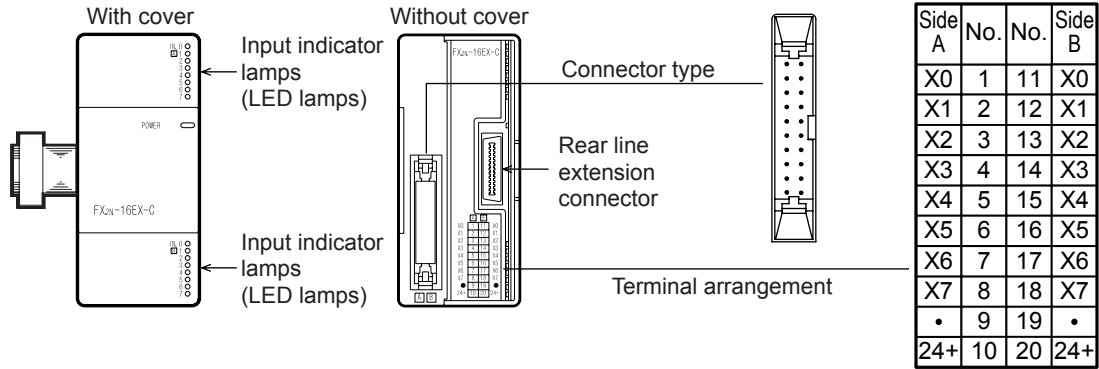

16.5.3 External dimensions

FX2N-8EX

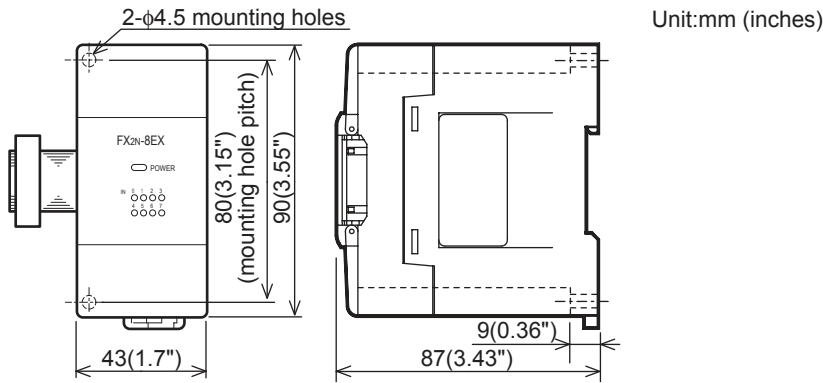

FX2N-16EX

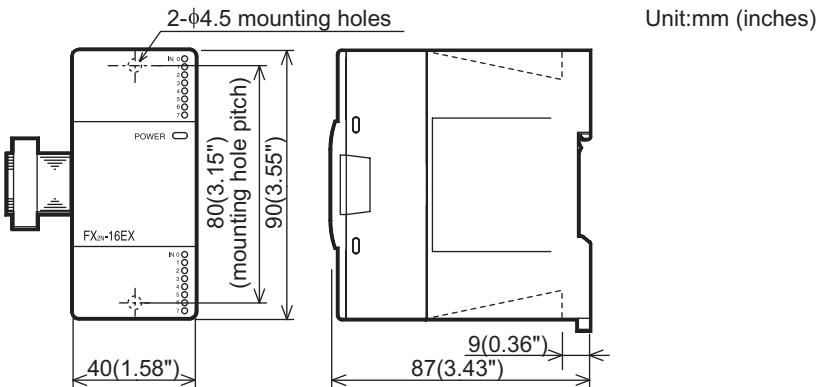

11 High-Speed Counters

12 Output Wiring

13 Wiring for Various Uses

14 Test Run, Maintenance, Troubleshooting

15 Input/Output Powered Extension Units

16 Input/Output Extension Blocks

17 Extension Power Supply Unit

18 Other Extension Units and Options

19 Display Module

20 Terminal Block

FX2N-16EX-C

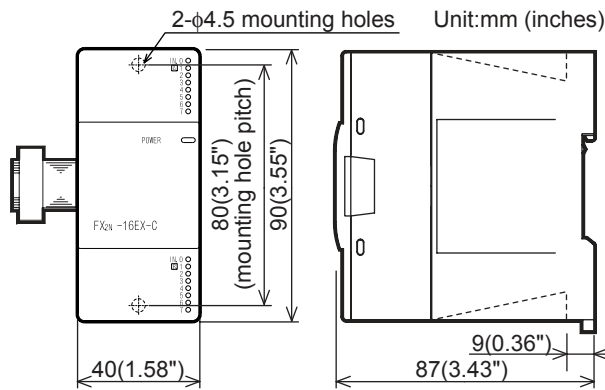

How to connect connector (FX2N-16EX-C)

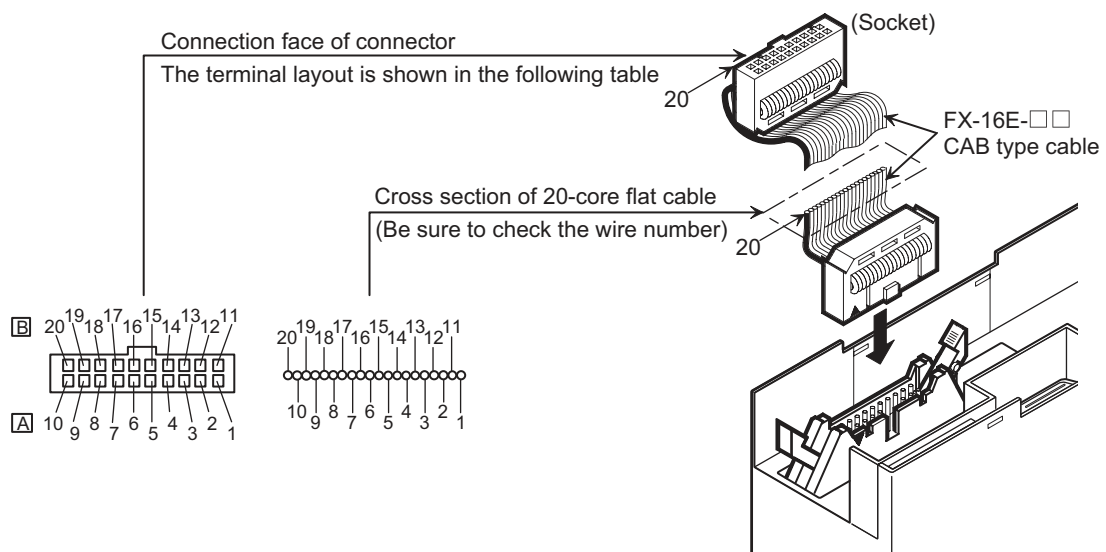

Side B	24+	•	X7	X6	X5	X4	X3	X2	X1	X0
Side A	24+	•	X7	X6	X5	X4	X3	X2	X1	X0

Side B is for the higher input numbers, and side A is for the lower input numbers.
 (Exe.) Side B X050 to X057
 Side A X040 to X047

16.6 FX2N-16EXL-C (5V DC Input: 16 Points)

16.6.1 Product specifications

The generic specifications are identical to the main unit specifications.

→ Refer to Section 4.1 for generic specifications.

1. Power supply specifications

Item	FX2N-16EXL-C
Product type	FX2N connector type extension block for each application
Rated voltage	24V DC (supplied from main unit and input/output powered extension unit)

2. Weight and Other specifications

Item	FX2N-16EXL-C
MASS (Weight)	0.3 kg (0.66lbs)
Other	<ul style="list-style-type: none"> The extension cable is already connected to the extension block. Accessories: Label for indication of input/output number The DIN46277 rail (width: 35 mm (1.38")) or direct installation.

3. Input specifications

Item	FX2N-16EXL-C	
Input points	16 points	
Connection unit	Connector terminal block	
Input type	TTL level	
Input signal voltage	5V DC \pm 5%	
Input signal current	20 mA (at 5V DC), maximum	
Input impedance	2.2k Ω	
Input sensitivity current	ON(Low)	1 mA or more
	OFF(High)	0.4 mA or less
Input sensitivity voltage	ON(Low)	1.5V DC or less
	OFF(High)	3.5V DC or more
Input response time	OFF→ON (High→Low)	1 ms +1 ms, -0.5 ms
	ON→OFF (Low→High)	1 ms +1 ms, -0.5 ms
Input signal type	TTL input	
Input circuit insulation	Photo-coupler insulation	
Indication of input operation	LED on panel lights when input.	
Input circuit diagram	<p>The diagram illustrates the input circuit. It shows a photo-coupler with an LED on the input side and a phototransistor on the output side. A 2.2kΩ resistor is connected between the input terminal and the LED. The LED is connected to a 5V DC supply. The phototransistor output is connected to a TTL input terminal. The 5V DC supply is provided by an external unit.</p>	

16.6.2 Parts identification and terminal arrangement

When an input (X) number is assigned, 8 points on side A will be used for the lower input numbers, and 8 points on side B will be used for the higher input numbers.

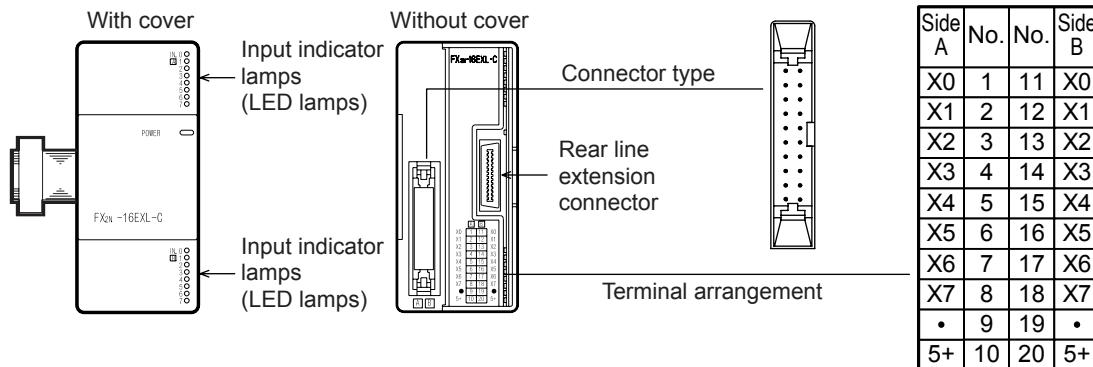

16.6.3 External dimensions

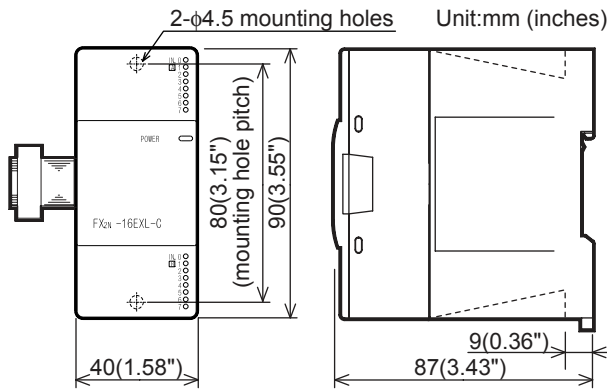

16.6.4 Example of wiring

1. Wiring on input side

Sink input

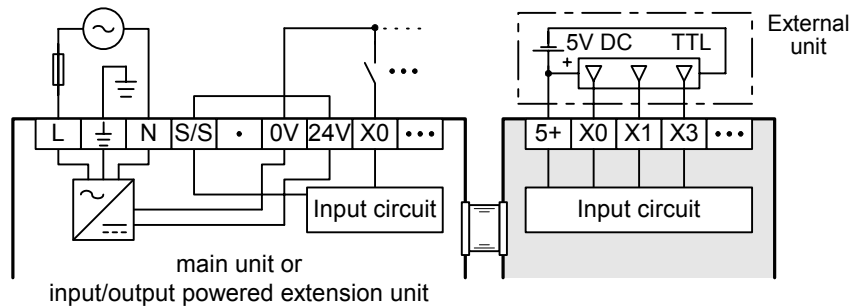

How to connect connector

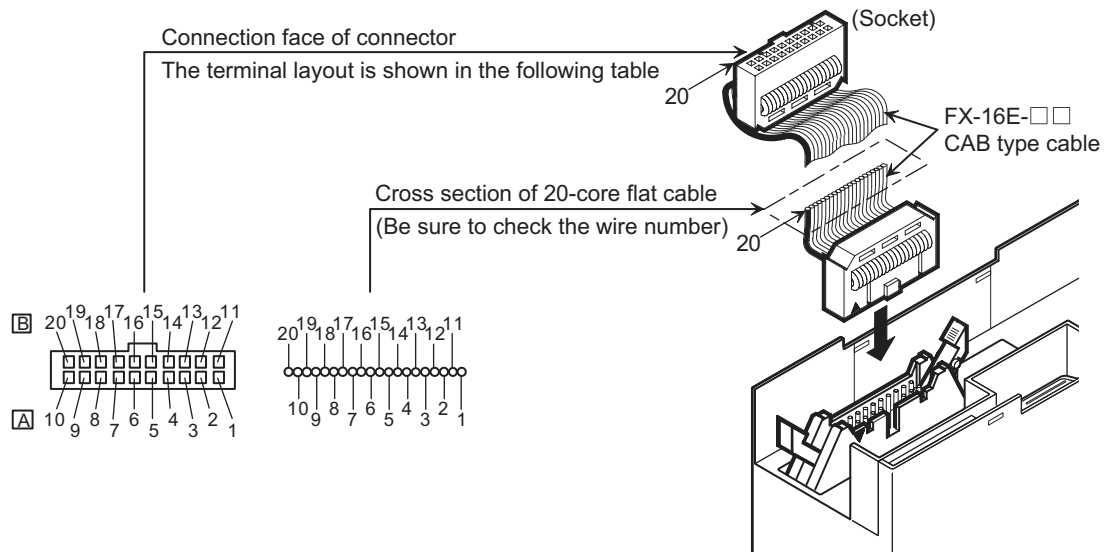

Side B	5+	•	X7	X6	X5	X4	X3	X2	X1	X0
Side A	5+	•	X7	X6	X5	X4	X3	X2	X1	X0

Side B is for the higher input numbers,
 and side A is for the lower input numbers.
 (Exe.) Side B X050 to X057
 Side A X040 to X047

11	High-Speed Counters
12	Output Wiring
13	Wiring for Various Uses
14	Test Run, Maintenance, Troubleshooting
15	Input/Output Powered Extension Units
16	Input/Output Extension Blocks
17	Extension Power Supply Unit
18	Other Extension Units and Options
19	Display Module
20	Terminal Block

16.7 FX2N-8EX-UA1/UL (100V AC Input)

16.7.1 Product specifications

The generic specifications are identical to the main unit specifications.

→ Refer to Section 4.1 for generic specifications.

For external wiring, refer to the following chapter.

→ Refer to Chapter 10 for input wiring.

1. Power supply specifications

Item	FX2N-8EX-UA1/UL
Product type	FX2N extension block
Rated voltage	24V DC (supplied from main unit and input/output powered extension unit)

2. Weight and Other specifications

Item	FX2N-8EX-UA1/UL
MASS (Weight)	0.2 kg (0.44lbs)
Other	<ul style="list-style-type: none"> The extension cable is already connected to the extension block. Accessories: Label for indication of input/output number The DIN46277 rail (width: 35 mm (1.38")) or direct installation.

3. Input specifications

Item	FX2N-8EX-UA1/UL	
Input points	8 points	
Connection unit	Vertical terminal block (M3 screws) / For a detailed description of wiring, refer to the input line connection diagram of the main unit.	
Input type	AC input	
Input signal voltage	100 to 120V AC	
Input signal current	6.2mA/110V AC 60Hz 4.7mA/100V AC 50Hz	
Input impedance	Approx. 21kΩ/50Hz Approx. 18kΩ/60Hz	
Input sensitivity current	Input-ON current	3.8mA/80V AC or more
	Input-OFF current	1.7mA/30V AC or less
Input response time	Approx. 25 to 30 ms	
Input signal type	Voltage contact	
Input circuit insulation	Photocoupler insulation	
Indication of input operation	LED on panel lights when input.	

Input circuit diagram

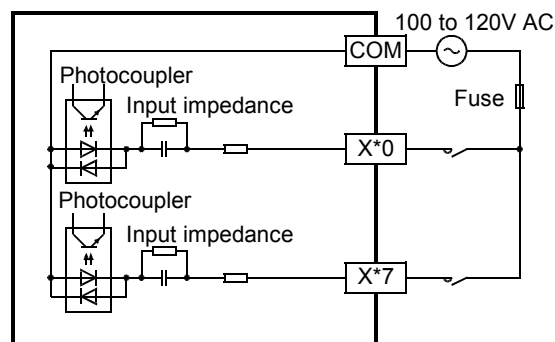

16.7.2 Parts identification and terminal arrangement

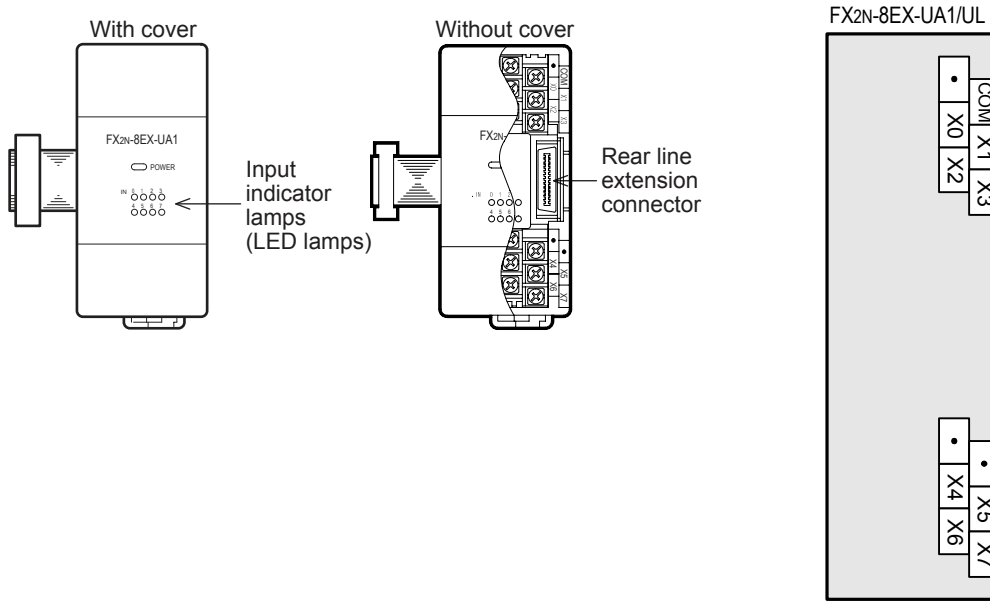

16.7.3 External dimensions

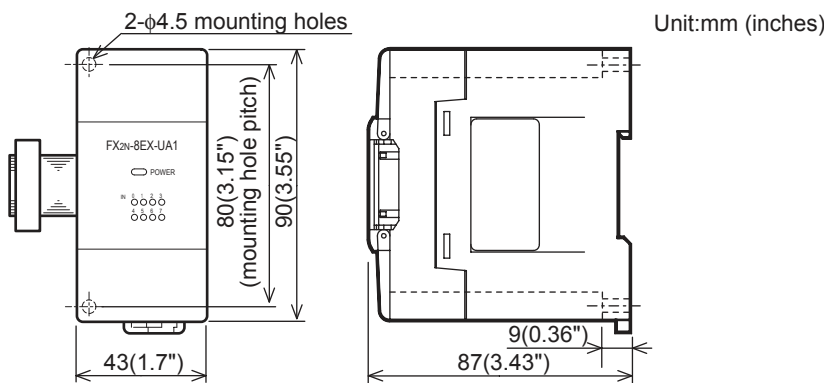

11	High-Speed Counters
12	Output Wiring
13	Wiring for Various Uses
14	Test Run, Maintenance, Troubleshooting
15	Input/Output Powered Extension Units
16	Input/Output Extension Blocks
17	Extension Power Supply Unit
18	Other Extension Units and Options
19	Display Module
20	Terminal Block

16.8 FX2N-8EYR-ES/UL, FX2N-8EYR-S-ES/UL, FX2N-16EYR-ES/UL (Relay Output)

16.8.1 Product specifications

The generic specifications are identical to the main unit specifications.

→ Refer to Section 4.1 for generic specifications.

For external wiring, refer to the following chapter.

→ Refer to Chapter 12 for output wiring.

1. Power supply specifications

Item	FX2N-8EYR-ES/UL	FX2N-16EYR-ES/UL	FX2N-8EYR-S-ES/UL
Product type	FX2N extension block		
Rated voltage	24V DC (supplied from main unit and input/output powered extension unit)		

2. Weight and Other specifications

Item	FX2N-8EYR-ES/UL	FX2N-16EYR-ES/UL	FX2N-8EYR-S-ES/UL
MASS (Weight)	0.2 kg (0.44lbs)	0.3 kg (0.66lbs)	
Others	<ul style="list-style-type: none"> The extension cable is already connected to the extension block. Accessories: Label for indication of input/output number The DIN46277 rail (width: 35 mm (1.38")) or direct installation. 		

3. Output specifications (Relay output type)

Item	FX2N-8EYR-ES/UL	FX2N-16EYR-ES/UL	FX2N-8EYR-S-ES/UL
Output points	8 points	16 points	8 points (All points have separate reference terminals (commons))
Connection unit	Vertical terminal block (M3 screws)		
Output unit	Relay		
External power supply	30V DC or less 240V AC or less (250V AC or less when the unit does not comply with CE, UL, or cUL standards)		
Output circuit insulation method	Mechanical insulation		
Indication of output operation	Supplying power to the relay coil will light the LED indicator lamp on panel.		
Maximum load	Resistance load	2 A/point The total resistance load current per common should be as follows: <ul style="list-style-type: none"> 4 output points/common: 8A or less 8 output points/common: 8A or less 	2 A/point
	Inductive load	80 VA → For the product life, refer to Subsection 4.4.2. → For cautions on external wiring, refer to Subsection 12.2.4.	
Open circuit leakage current	-		
Minimum load	5V DC, 2 mA (reference values)		
Response time	OFF→ON	Approx. 10 ms	
	ON→OFF	Approx. 10 ms	

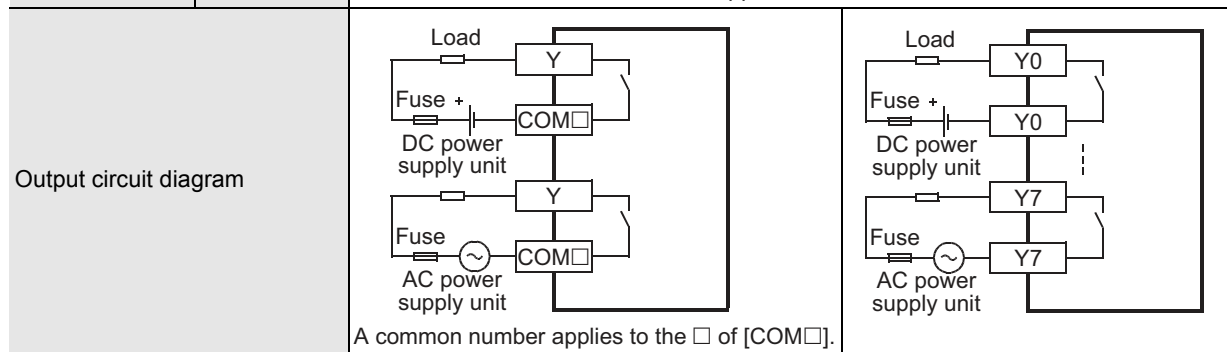

16.8.2 Parts identification and terminal arrangement

FX2N-8EYR-ES/UL

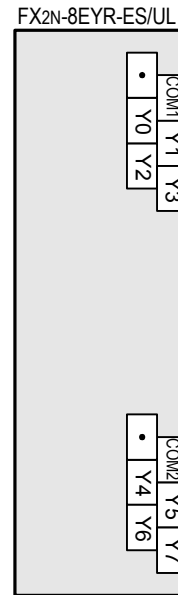
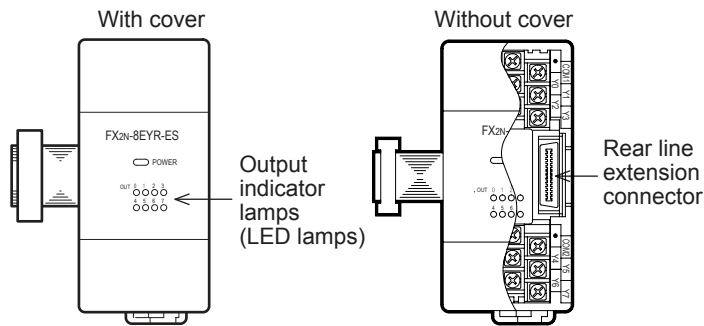

FX2N-8EYR-S-ES/UL

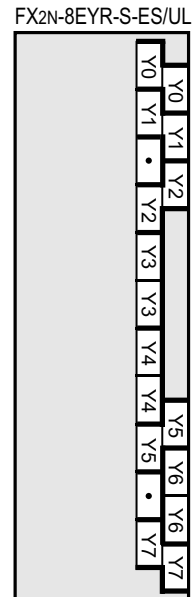
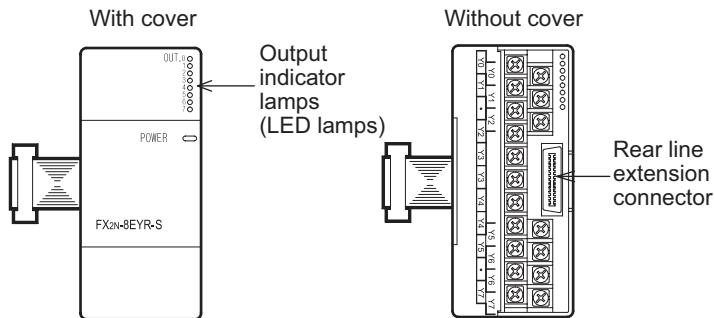

11	High-Speed Counters
12	Output Wiring
13	Wiring for Various Uses
14	Test Run, Maintenance, Troubleshooting
15	Input/Output Powered Extension Units
16	Input/Output Extension Blocks
17	Extension Power Supply Unit
18	Other Extension Units and Options
19	Display Module
20	Terminal Block

FX2N-16EYR-ES/UL

When an output (Y) number is assigned, 8 points on the upper side will be used for the lower output numbers, and 8 points on the lower side will be used for the higher output numbers.

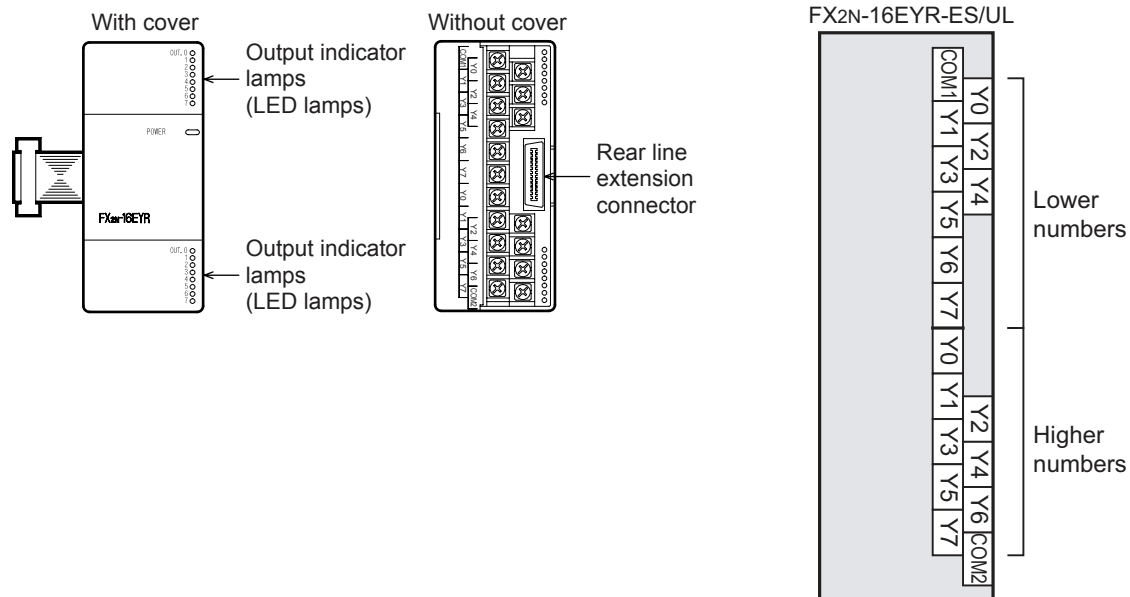

16.8.3 External dimensions

FX2N-8EYR-ES/UL

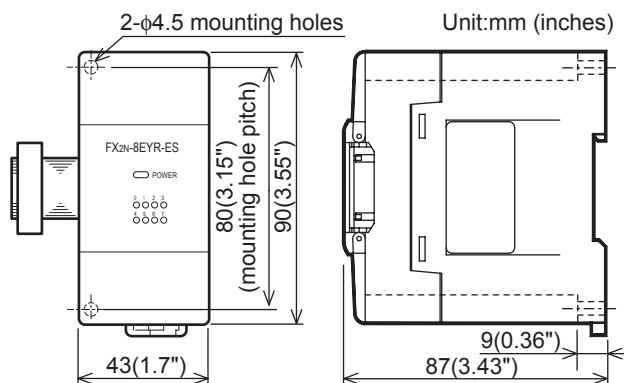

FX2N-8EYR-S-ES/UL

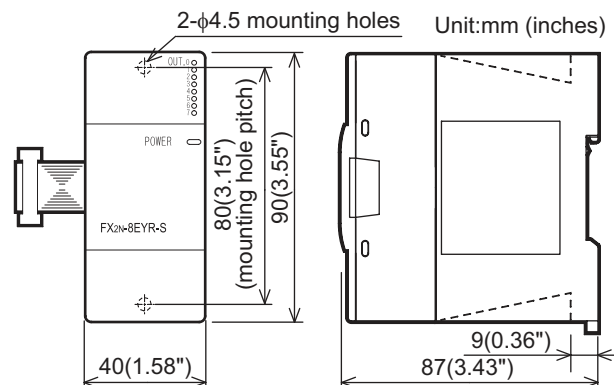

FX2N-16EYR-ES/UL

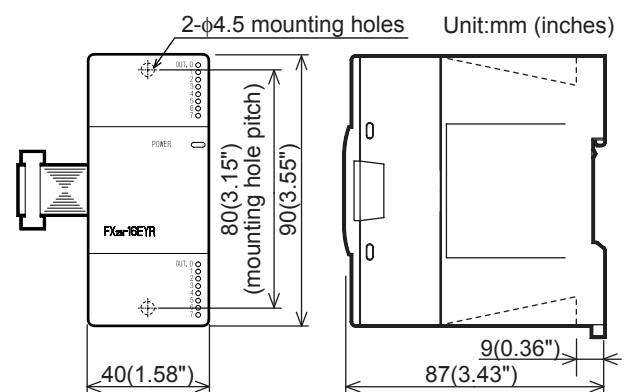

11	High-Speed Counters
12	Output Wiring
13	Wiring for Various Uses
14	Test Run, Maintenance, Troubleshooting
15	Input/Output Powered Extension Units
16	Input/Output Extension Blocks
17	Extension Power Supply Unit
18	Other Extension Units and Options
19	Display Module
20	Terminal Block

16.9 FX2N-8EYT-ESS/UL, FX2N-16EYT-ESS/UL (Transistor Output)

16.9.1 Product specifications

The generic specifications are identical to the main unit specifications.

→ Refer to Section 4.1 for generic specifications.

For external wiring, refer to the following chapter.

→ Refer to Chapter 12 for output wiring.

1. Power supply specifications

Item	FX2N-8EYT-ESS/UL	FX2N-16EYT-ESS/UL
Product type	FX2N extension block	
Rated voltage	24V DC (supplied from main unit and input/output powered extension unit)	

2. Weight and Other specifications

Item	FX2N-8EYT-ESS/UL	FX2N-16EYT-ESS/UL
MASS (Weight)	0.2 kg (0.44lbs)	0.3 kg (0.66lbs)
Other	<ul style="list-style-type: none"> The extension cable is already connected to the extension block. Accessories: Label for indication of input/output number The DIN46277 rail (width: 35 mm (1.38")) or direct installation. 	

3. Output specifications (Transistor output type)

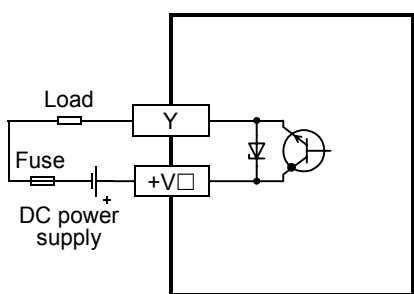
Item	FX2N-8EYT-ESS/UL	FX2N-16EYT-ESS/UL
Output points	8 points	16 points
Connection unit	Vertical terminal block (M3 screws)	
Output unit/type	Transistor/source output	
External power supply	5 to 30V DC	
Output circuit insulation method	Photo-coupler insulation	
Indication of output operation	Activation of the photo-coupler will light the LED indicator lamp on panel.	
Maximum load	Resistance load	0.5 A/point The total load current per common should be as follows: <ul style="list-style-type: none"> 4 output points/common: 0.8A or less 8 output points/common: 1.6A or less
	Inductive load	12 W/24V DC
Open circuit leakage current	0.1 mA/30 A DC	
Minimum load	-	
Response time	OFF→ON	0.2 ms or less for 200 mA (at 24V DC)
	ON→OFF	0.2 ms or less for 200 mA (at 24V DC)
Output circuit diagram	 <p>A common number applies to the □ of [+V□].</p>	

16.9.2 Parts identification and terminal arrangement

FX2N-8EYT-ESS/UL

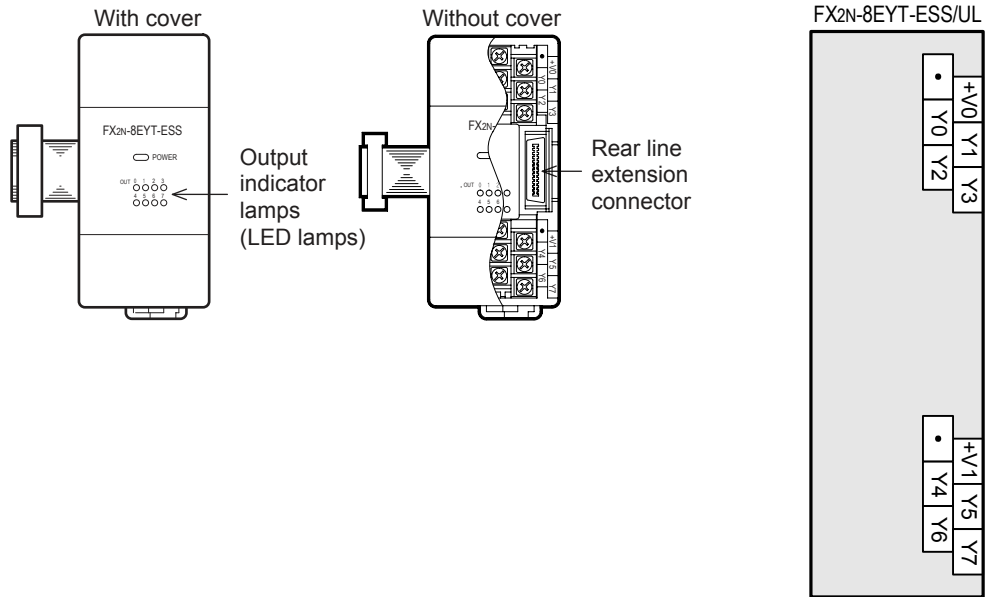

FX2N-16EYT-ESS/UL

When an output (Y) number is assigned, 8 points on the upper side will be used for the lower output numbers, and 8 points on the lower side will be used for the higher output numbers.

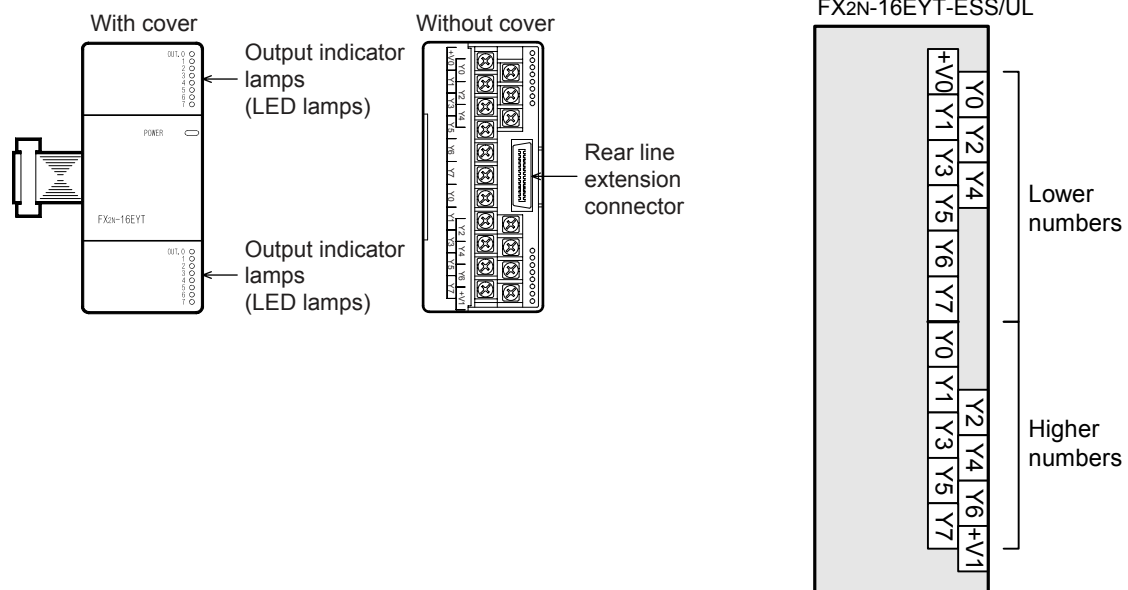

11	High-Speed Counters
12	Output Wiring
13	Wiring for Various Uses
14	Test Run, Maintenance, Troubleshooting
15	Input/Output Powered Extension Units
16	Input/Output Extension Blocks
17	Extension Power Supply Unit
18	Other Extension Units and Options
19	Display Module
20	Terminal Block

16.9.3 External dimensions

FX2N-8EYT-ESS/UL

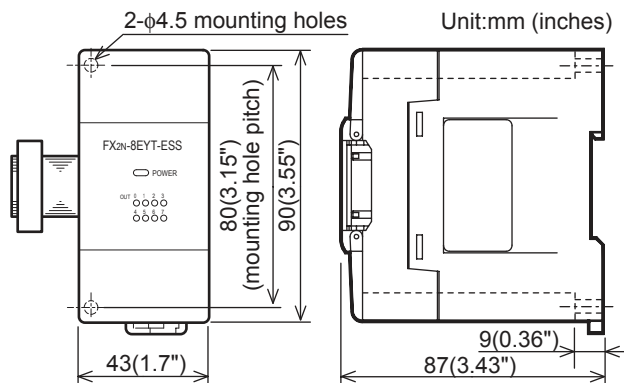

FX2N-16EYT-ESS/UL

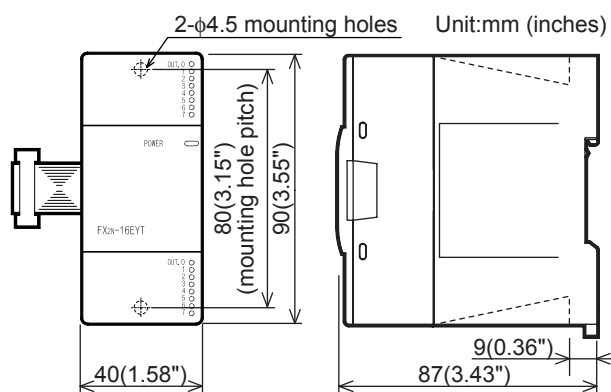

16.10 FX2N-8EYR, FX2N-16EYR (Relay Output)

16.10.1 Product specifications

The generic specifications are identical to the main unit specifications.

→ Refer to Section 4.1 for generic specifications.

For external wiring, refer to the following chapter.

→ Refer to Chapter 12 for output wiring.

1. Power supply specifications

Item	FX2N-8EYR	FX2N-16EYR
Product type	FX2N extension block	
Rated voltage	24V DC (supplied from main unit and input/output powered extension unit)	

2. Weight and Other specifications

Item	FX2N-8EYR	FX2N-16EYR
MASS (Weight)	0.2 kg (0.44lbs)	0.3 kg (0.66lbs)
Other	<ul style="list-style-type: none"> The extension cable is already connected to the extension block. Accessories: Label for indication of input/output number The DIN46277 rail (width: 35 mm (1.38")) or direct installation. 	

3. Output specifications (Relay output type)

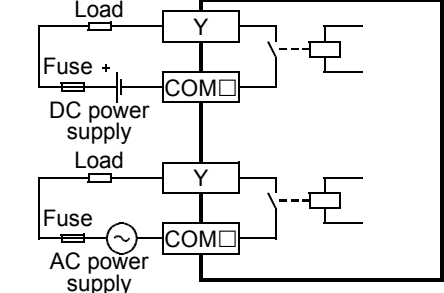
Item	FX2N-8EYR	FX2N-16EYR
Output points	8 points	16 points
Connection unit	Vertical terminal block (M3 screws)	
Output unit	Relay	
External power supply	250V AC 30V DC or less	
Output circuit insulation method	Mechanical insulation	
Indication of output operation	Supplying power to the relay coil will light the LED indicator lamp on panel.	
Maximum load	Resistance load	2 A/point The total resistance load current per common should be as follows: <ul style="list-style-type: none"> 4 output points/common: 8A or less 8 output points/common: 8A or less
	Inductive load	80 VA → For the product life, refer to Subsection 4.4.2. → For cautions on external wiring, refer to Subsection 12.2.4.
Open circuit leakage current	-	
Minimum load	5V DC, 2 mA (reference values)	
Response time	OFF→ON	Approx. 10 ms
	ON→OFF	Approx. 10 ms
Output circuit diagram	 <p>A common number applies to the □ of [COM□].</p>	

16.10.2 Parts identification and terminal arrangement

FX2N-8EYR

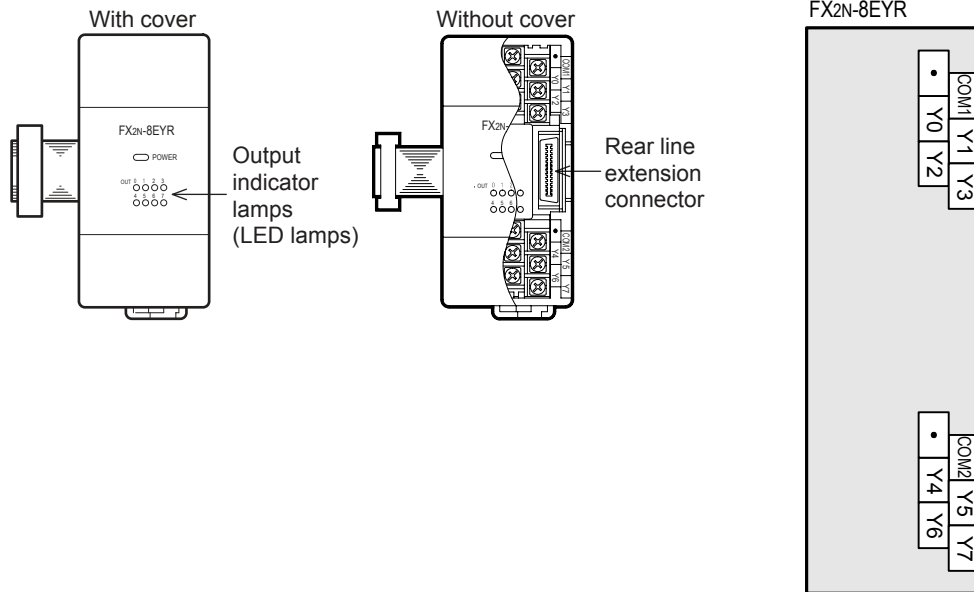

FX2N-16EYR

When an output (Y) number is assigned, 8 points on the upper side will be used for the lower output numbers, and 8 points on the lower side will be used for the higher output numbers.

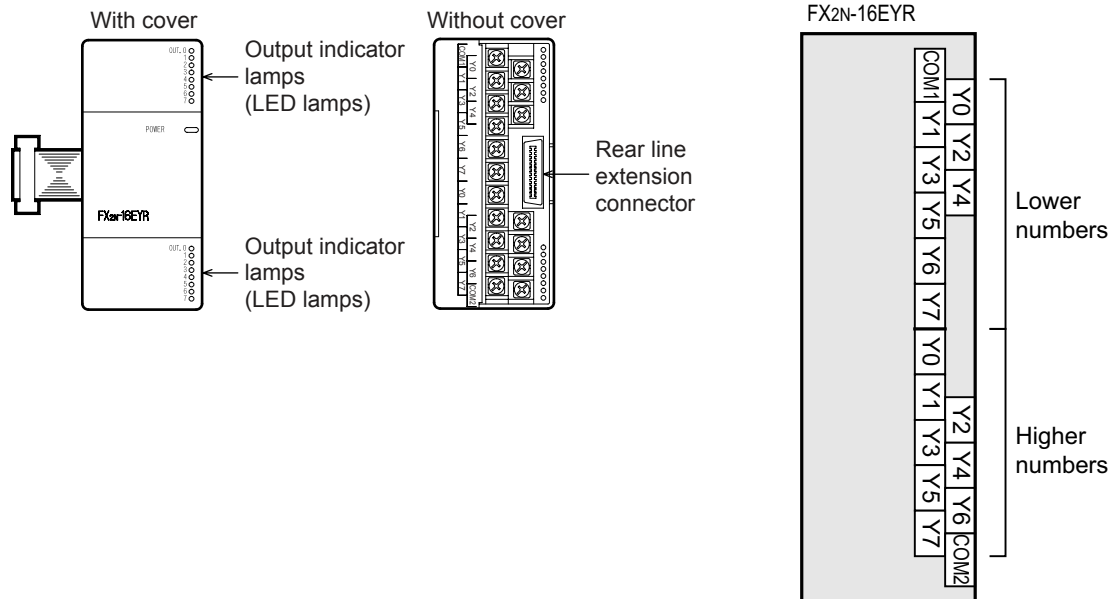

16.10.3 External dimensions

FX2N-8EYR

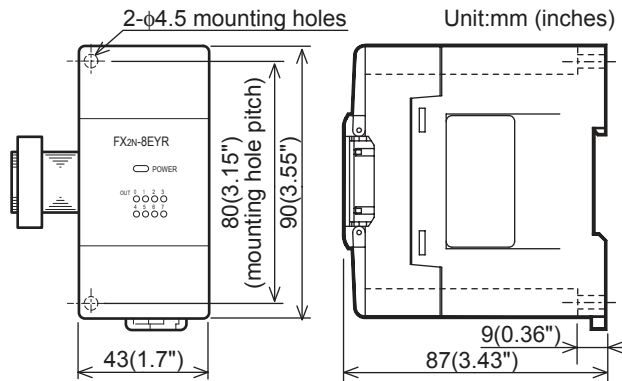

FX2N-16EYR

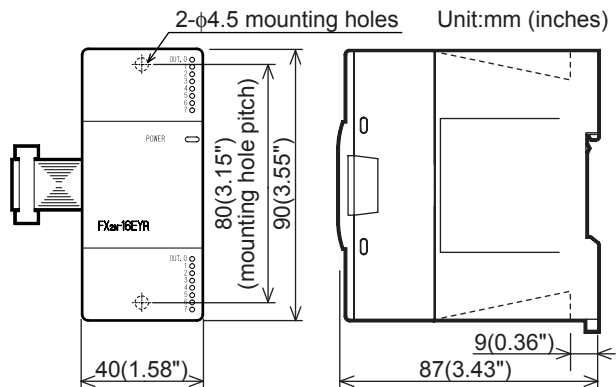

11	High-Speed Counters
12	Output Wiring
13	Wiring for Various Uses
14	Test Run, Maintenance, Troubleshooting
15	Input/Output Powered Extension Units
16	Input/Output Extension Blocks
17	Extension Power Supply Unit
18	Other Extension Units and Options
19	Display Module
20	Terminal Block

16.11 FX2N-8EYT, FX2N-16EYT and FX2N-16EYT-C (Transistor Output)

16.11.1 Product specifications

The generic specifications are identical to the main unit specifications.

→ Refer to Section 4.1 for generic specifications.

For external wiring, refer to the following chapter.

→ Refer to Chapter 12 for output wiring.

1. Power supply specifications

Item	FX2N-8EYT	FX2N-16EYT	FX2N-16EYT-C
Product type	FX2N extension block		FX2N connector type extension block
Rated voltage	24V DC (supplied from main unit and input/output powered extension unit)		

2. Weight and Other specifications

Item	FX2N-8EYT	FX2N-16EYT	FX2N-16EYT-C
MASS (Weight)	0.2 kg (0.44lbs)	0.3 kg (0.66lbs)	
Other	<ul style="list-style-type: none"> The extension cable is already connected to the extension block. Accessories: Label for indication of input/output number The DIN46277 rail (width: 35 mm (1.38")) or direct installation. 		

3. Output specifications (Transistor output type)

Item	FX2N-8EYT	FX2N-16EYT	FX2N-16EYT-C
Output points	8 points	16 points	
Connection unit	Vertical terminal block (M3 screws)		Connector terminal block
Output unit/type	Transistor/sink output		
External power supply	5 to 30V DC		
Output circuit insulation method	Photo-coupler insulation		
Indication of output operation	Activation of the photo-coupler will light the LED indicator lamp on panel.		
Maximum load	Resistance load	0.5 A/point The total load current per common should be as follows: <ul style="list-style-type: none"> 4 output points/common: 0.8A or less 8 output points/common: 1.6A or less 	0.3 A/point The total load current per common should be as follows: <ul style="list-style-type: none"> 16 output points/common: 1.6A or less
	Inductive load	12 W/24V DC	7.2 W/24V DC
Open circuit leakage current	0.1 mA/30 A DC		
Minimum load	-		
Response time	OFF→ON	0.2 ms or less for 200 mA (at 24V DC)	
	ON→OFF	0.2 ms or less for 200 mA (at 24V DC)	
Output circuit diagram			

16.11.2 Parts identification and terminal arrangement

FX2N-8EYT

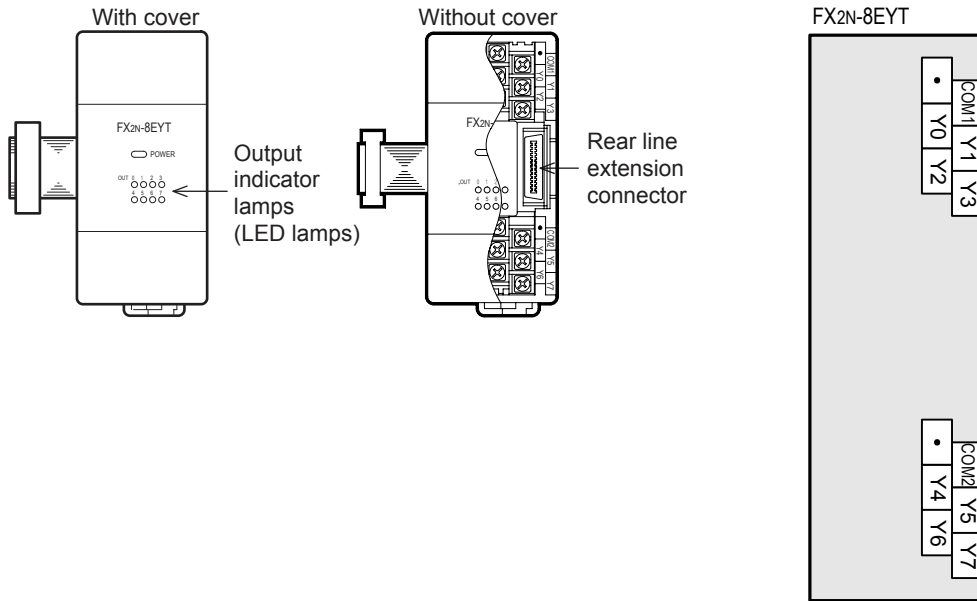

FX2N-16EYT

When an output (Y) number is assigned, 8 points on the upper side will be used for the lower output numbers, and 8 points on the lower side will be used for the higher output numbers.

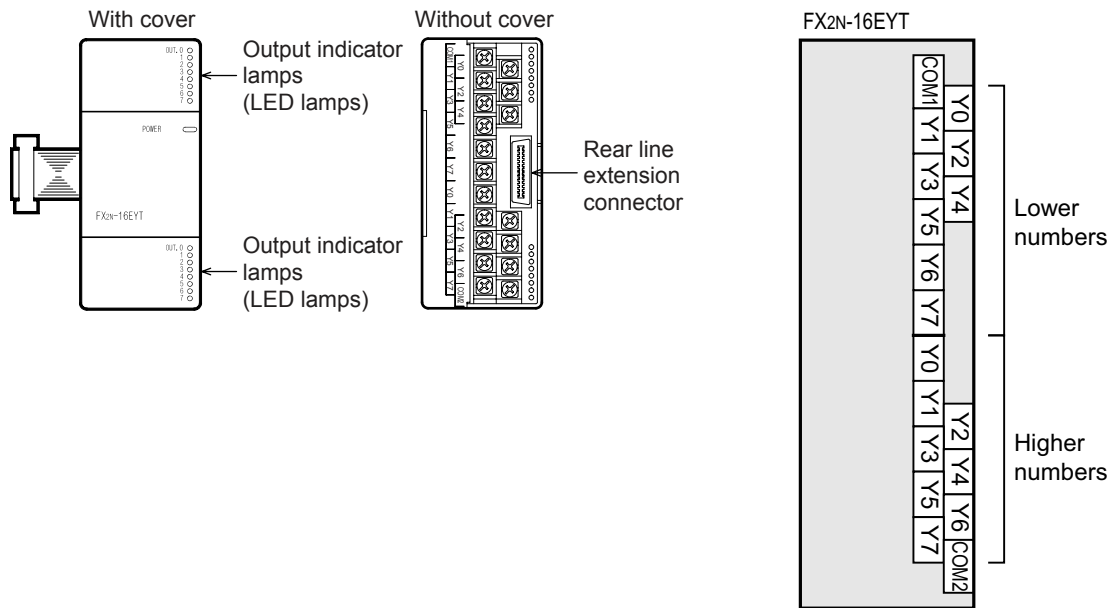

11 High-Speed Counters

12 Output Wiring

13 Wiring for Various Uses

14 Test Run, Maintenance, Troubleshooting

15 Input/Output Powered Extension Units

16 Input/Output Extension Blocks

17 Extension Power Supply Unit

18 Other Extension Units and Options

19 Display Module

20 Terminal Block

FX2N-16EYT-C

When an output (Y) number is assigned, 8 points on side A will be used for the lower output numbers, and 8 points on side B will be used for the higher output numbers.

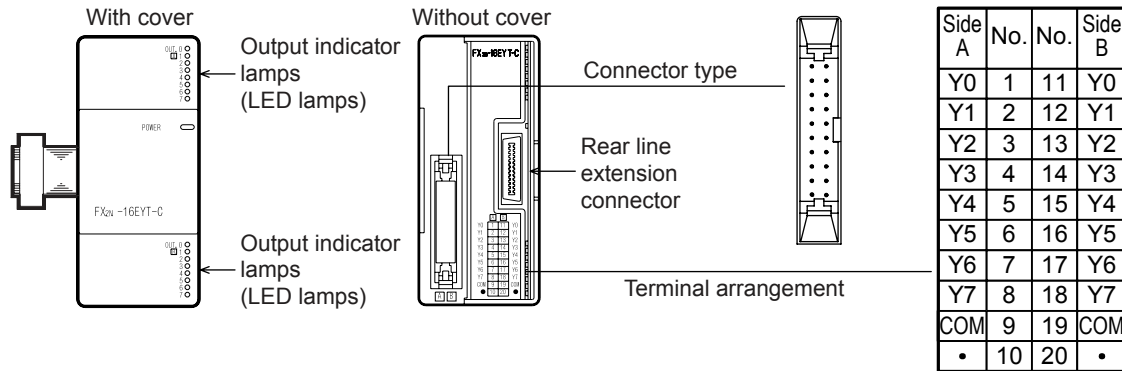

16.11.3 External dimensions

FX2N-8EYT

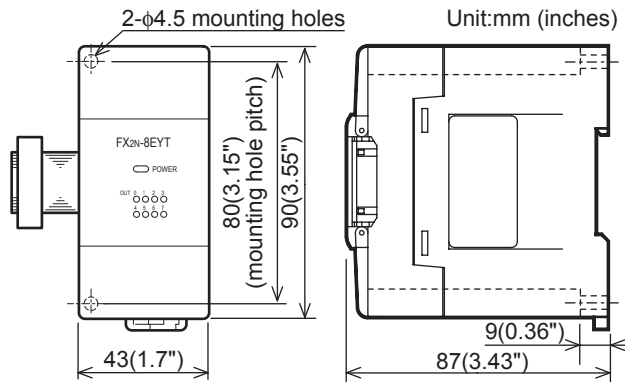

FX2N-16EYT

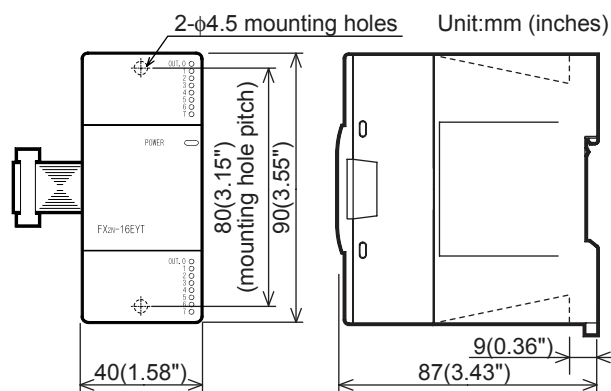

FX2N-16EYT-C

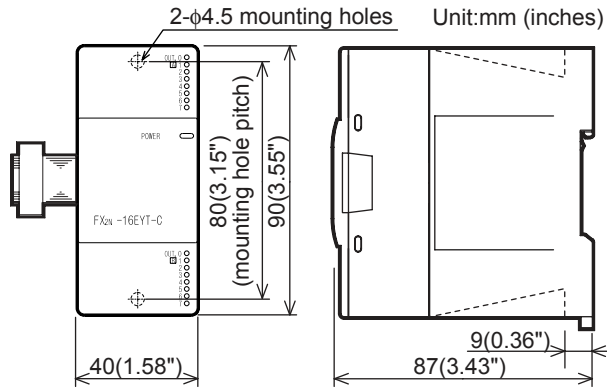

How to connect connector (FX2N-16EYT-C)

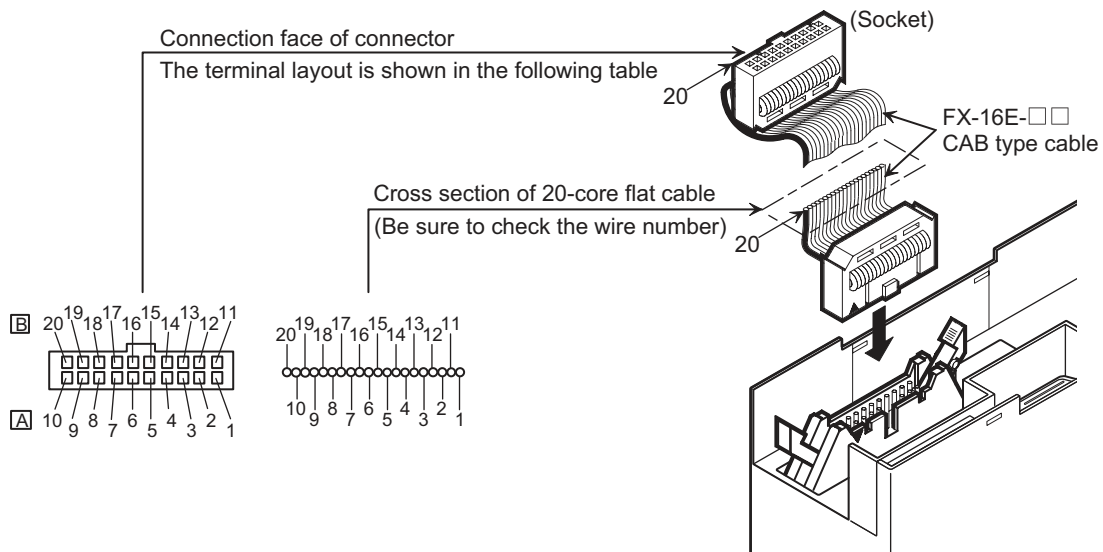

Side B	•	COM	Y7	Y6	Y5	Y4	Y3	Y2	Y1	Y0
Side A	•	COM	Y7	Y6	Y5	Y4	Y3	Y2	Y1	Y0

Side B is for the higher input numbers,
 and side A is for the lower input numbers.
 (Exe.) Side B X050 to X057
 Side A X040 to X047

11 High-Speed Counters

12 Output Wiring

13 Wiring for Various Uses

14 Test Run, Maintenance, Troubleshooting

15 Input/Output Powered Extension Units

16 Input/Output Extension Blocks

17 Extension Power Supply Unit

18 Other Extension Units and Options

19 Display Module

20 Terminal Block

16.12 FX2N-8EYT-H (Transistor Output)

16.12.1 Product specifications

The generic specifications are identical to the main unit specifications.

→ Refer to Section 4.1 for generic specifications.

For external wiring, refer to the following chapter.

→ Refer to Chapter 12 for output wiring.

1. Power supply specifications

Item	FX2N-8EYT-H
Product type	FX2N extension block
Rated voltage	24V DC (supplied from main unit and input/output powered extension unit)

2. Weight and Other specifications

Item	FX2N-8EYT-H
MASS (Weight)	0.2 kg (0.44lbs)
Other	<ul style="list-style-type: none"> The extension cable is already connected to the extension block. Accessories: Label for indication of input/output number The DIN46277 rail (width: 35 mm (1.38")) or direct installation.

3. Output specifications (Transistor output type)

Item	FX2N-8EYT-H	
Output points	8 points	
Connection unit	Vertical terminal block (M3 screws)	
Output unit/type	Transistor/sink output	
External power supply	5 to 30V DC	
Output circuit insulation method	Photo-coupler insulation	
Indication of output operation	Activation of the photo-coupler will light the LED indicator lamp on panel.	
Maximum load	Resistance load	1A/point The total load current per common should be as follows: <ul style="list-style-type: none"> 4 output points/common: 2A or less
	Inductive load	24W/24V DC
Open circuit leakage current	0.1 mA/30V DC	
Minimum load	-	
Response time	OFF→ON	0.2 ms or less/1A
	ON→OFF	0.4 ms or less/1A

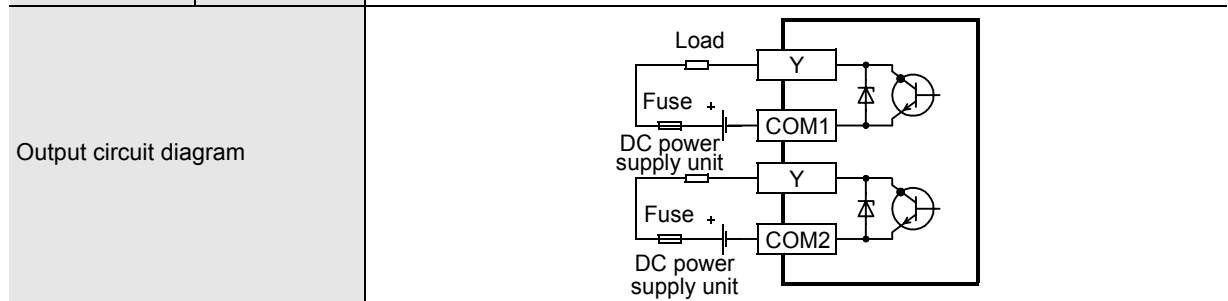

16.12.2 Parts identification and terminal arrangement

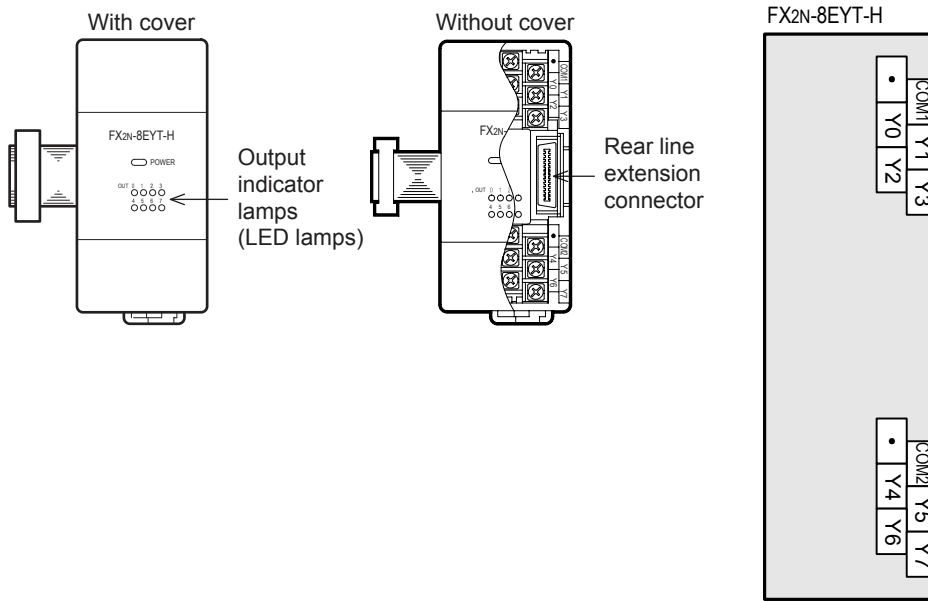

16.12.3 External dimensions

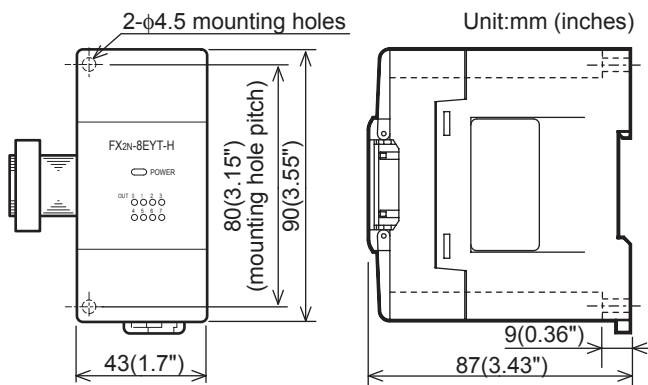

11	High-Speed Counters
12	Output Wiring
13	Wiring for Various Uses
14	Test Run, Maintenance, Troubleshooting
15	Input/Output Powered Extension Units
16	Input/Output Extension Blocks
17	Extension Power Supply Unit
18	Other Extension Units and Options
19	Display Module
20	Terminal Block

16.13 FX2N-16EYS (Triac Output: 16 Points)

16.13.1 Product specifications

The generic specifications are identical to the main unit specifications.

→ Refer to Section 4.1 for generic specifications.

For external wiring, refer to the following chapter.

→ Refer to Chapter 12 for output wiring.

1. Power supply specifications

Item	FX2N-16EYS
Product type	FX2N extension block
Rated voltage	24V DC (supplied from main unit and input/output powered extension unit)

2. Weight and Other specifications

Item	FX2N-16EYS
MASS (Weight)	0.3 kg (0.66lbs)
Other	<ul style="list-style-type: none"> The extension cable is already connected to the extension block. Accessories: Label for indication of input/output number The DIN46277 rail (width: 35 mm (1.38")) or direct installation.

3. Output specifications (Triac output type)

Item	FX2N-16EYS	
Output points	16 points	
Connection unit	Vertical terminal block (M3 screws)	
Output unit	Triac output (SSR)	
External power supply	85 to 242V AC	
Output circuit insulation method	Photo-coupler insulation	
Indication of output operation	Activation of the photo-thyristor will light the LED indicator lamp on panel.	
Maximum load	Resistance load	0.3 A/point The total load current per common should be as follows: <ul style="list-style-type: none"> 8 output points/common: 0.8A or less
	Inductive load	15 VA/100V AC, 30 VA/200V AC
Open circuit leakage current	1 mA/100V AC, 2 mA/200V AC	
Minimum load	0.4 VA/100V AC, 1.6 VA/200V AC	
Response time	OFF→ON	1 ms or less
	ON→OFF	10 ms or less

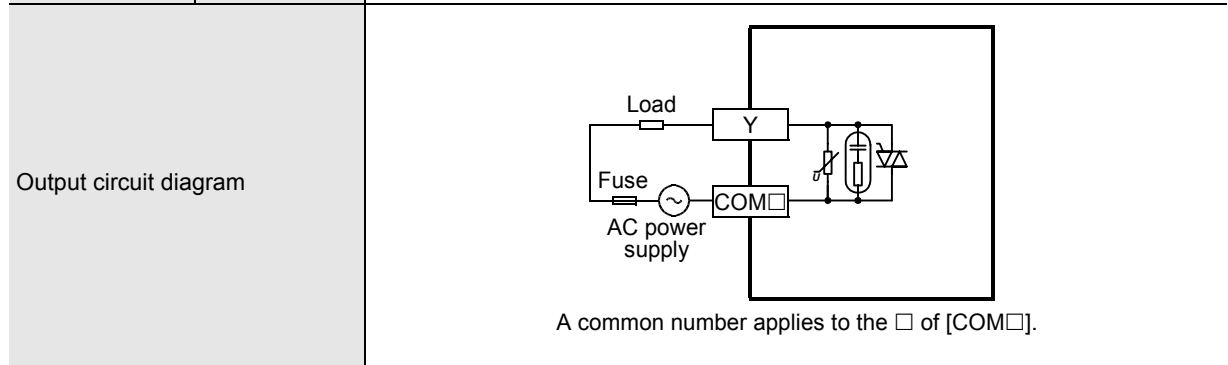

16.13.2 Parts identification and terminal arrangement

When an output (Y) number is assigned, 8 points on the upper side will be used for the lower output numbers, and 8 points on the lower side will be used for the higher output numbers.

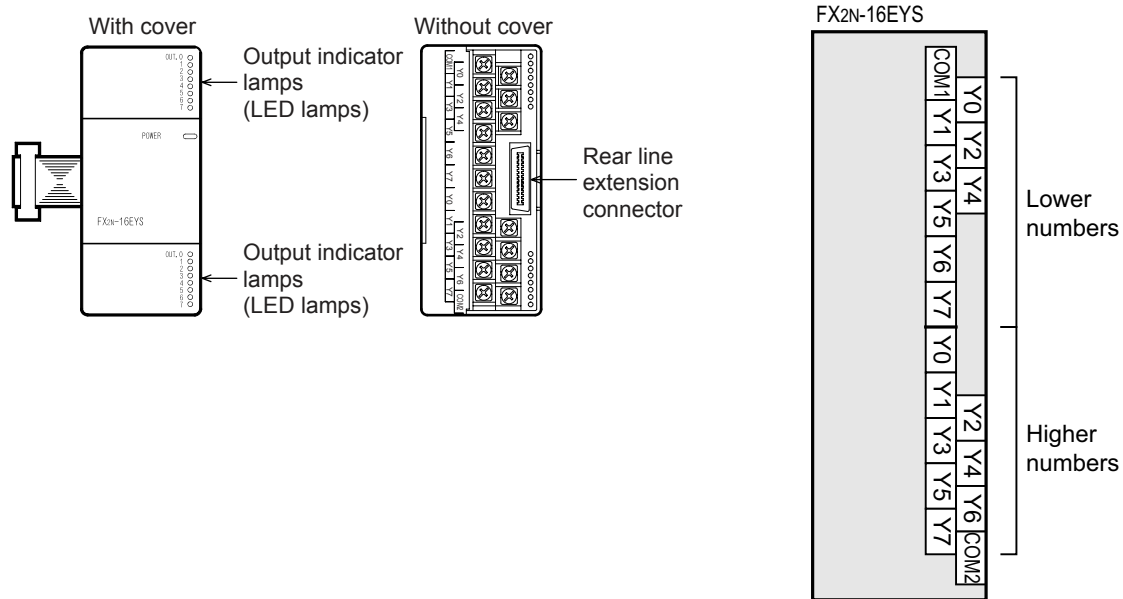

16.13.3 External dimensions

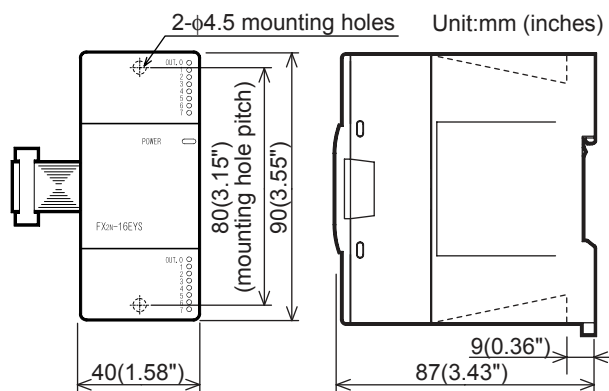

11	High-Speed Counters
12	Output Wiring
13	Wiring for Various Uses
14	Test Run, Maintenance, Troubleshooting
15	Input/Output Powered Extension Units
16	Input/Output Extension Blocks
17	Extension Power Supply Unit
18	Other Extension Units and Options
19	Display Module
20	Terminal Block

17. FX3U-1PSU-5V (Extension Power Supply Unit)

DESIGN PRECAUTIONS



- Make sure to have the following safety circuits outside of the PLC to ensure safe system operation even during external power supply problems or PLC failure.
Otherwise, malfunctions may cause serious accidents.
 - 1) Most importantly, have the following: an emergency stop circuit, a protection circuit, an interlock circuit for opposite movements (such as normal vs. reverse rotation), and an interlock circuit (to prevent damage to the equipment at the upper and lower positioning limits).
 - 2) Note that when the PLC CPU detects an error, such as a watchdog timer error, during self-diagnosis, all outputs are turned off. Also, when an error that cannot be detected by the PLC CPU occurs in an input/output control block, output control may be disabled.
External circuits and mechanisms should be designed to ensure safe machinery operation in such a case.
 - 3) Note that the output current of the 24V DC service power supply varies depending on the model and the absence/presence of extension blocks. If an overload occurs, the voltage automatically drops, inputs in the PLC are disabled, and all outputs are turned off.
External circuits and mechanisms should be designed to ensure safe machinery operation in such a case.
 - 4) Note that when an error occurs in a relay, triac or transistor output device, the output could be held either on or off.
For output signals that may lead to serious accidents, external circuits and mechanisms should be designed to ensure safe machinery operation in such a case.

DESIGN PRECAUTIONS



- Do not bundle the control line together with or lay it close to the main circuit or power line. As a guideline, lay the control line at least 100mm (3.94") or more away from the main circuit or power line.
Noise may cause malfunctions.
- Install module so that excessive force will not be applied to peripheral device connectors.
Failure to do so may result in wire damage/breakage or PLC failure.

17.1 Introduction

When the internal power supplied from the FX3U Series PLC (AC power supply type) is insufficient for powering output extension blocks or special function blocks, the FX3U-1PSU-5V (extension power supply unit) is available. Up to two units of FX3U-1PSU-5V may be connected in one system.

Connect extension equipment to the FX3U-1PSU-5V according to the configuration specification limits described in Subsection 17.2.2.

→ For the system configuration with FX3U-1PSU-5V, refer to Chapter 6.

→ For the mounting, refer to Chapter 8.

→ For the wiring, refer to Chapter 9.

17.2 Specifications

17.2.1 Generic Specifications

The generic specifications are the same as those for the main unit.

→ For the generic specifications, refer to Section 4.1.

17.2.2 Performance Specifications

Items		Specifications
Supply voltage		100-240V AC
Allowable supply voltage range		85-264V AC
Rated frequency		50/60Hz
Allowable instantaneous power failure time		The allowable momentary power failure time depends on the power supply used. <ul style="list-style-type: none"> 100V AC power supply system: The operation is continued to the momentary power failure for 10 or less ms. 200V AC power supply system: The operation is continued to the momentary power failure for 100 or less ms.
Rush current		30A max. 5ms or less/100V AC, 65A max. 5ms or less/200V AC
Power consumption		20W Max.
Output current (Internal for supply)	24V DC	0.3A ^{*1}
	5V DC	1A ^{*1}

*1. The output current is restricted, depending on the ambient temperature. For details, refer to the derating curve in Section 6.7.

17.2.3 External Dimensions

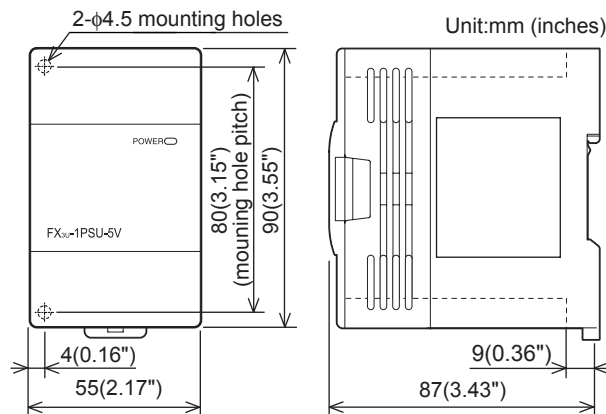

17.3 Extension Power Supply Unit Related Precaution

- Do not use when combining with a DC-power-supply type main unit.
- When connecting an input extension block (including FX2N-8ER-ES/UL, FX2N-8ER) to the FX3u-1PSU-5V, supply the power for it from the 24V DC service power supply of the connected main unit or powered extension unit on the upstream side.
- Grounding and power cables should be positioned to exit the unit from above.

→ For details, refer to Subsection 9.5.4 and 9.5.5.

18. Other Extension Devices and Optional Units (External Dimensions and Terminal Arrangement)

18.1 Special Function Units/Blocks

18.1.1 FX0N-3A

External Dimensions

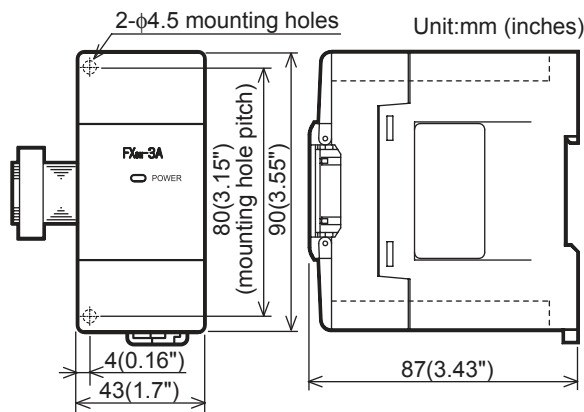

- MASS(Weight): 0.2kg (0.44lbs)
- Installation: 35 mm (1.38") wide DIN rail or screws
- Accessories: Label for indication of special unit/block number, Manual supplied with product
- Terminal block: M3 screws
- The extension cable is already connected to the extension block

Terminal Layout

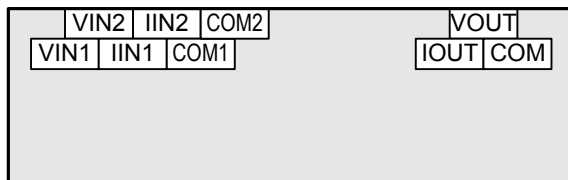

18.1.2 FX2N-2AD

External Dimensions

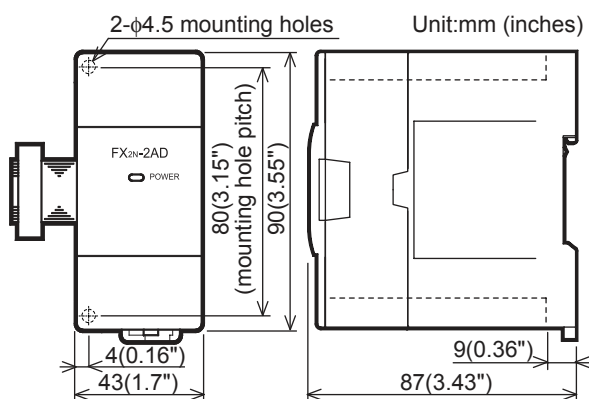

- MASS(Weight): 0.2kg (0.44lbs)
- Installation: 35 mm (1.38") wide DIN rail or screws
- Accessories: Label for indication of special unit/block number, Manual supplied with product
- Terminal block: M3 screws
- The extension cable is already connected to the extension block

Terminal Layout

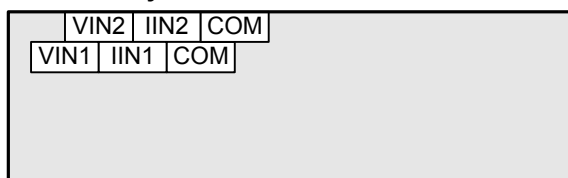

18.1.3 FX2N-2DA

External Dimensions

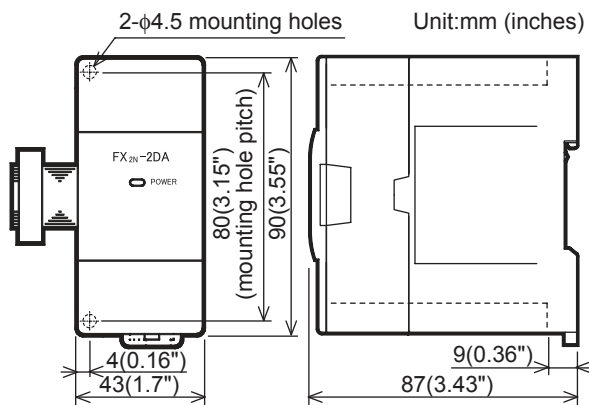

- MASS(Weight): 0.2kg (0.44lbs)
- Installation: 35 mm (1.38") wide DIN rail or screws
- Accessories: Label for indication of special unit/block number, Manual supplied with product
- Terminal block: M3 screws
- The extension cable is already connected to the extension block

Terminal Layout

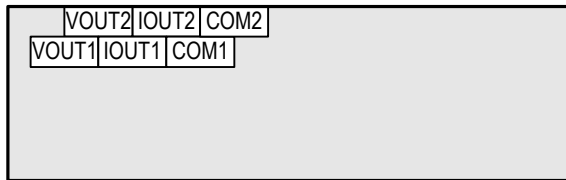

18.1.4 FX3U-4AD

External Dimensions

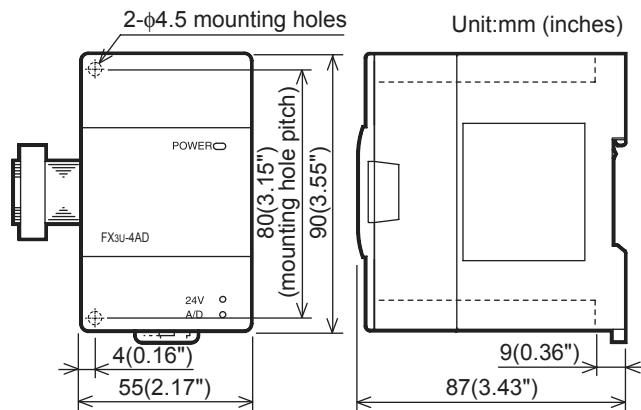

- MASS(Weight): 0.2kg (0.44lbs)
- Installation: 35 mm (1.38") wide DIN rail or screws
- Accessories: Label for indication of special unit/block number, Dust Proof sheet, Manual supplied with product
- Terminal block: M3 screws
- The extension cable is already connected to the extension block

Terminal Layout

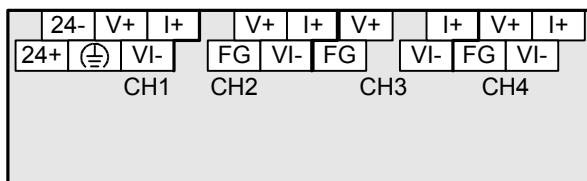

11	High-Speed Counters
12	Output Wiring
13	Wiring for Various Uses
14	Test Run, Maintenance, Troubleshooting
15	Input/Output Powered Extension Units
16	Input/Output Extension Blocks
17	Extension Power Supply Unit
18	Other Extension Units and Options
19	Display Module
20	Terminal Block

18.1.5 FX3U-4DA

External Dimensions

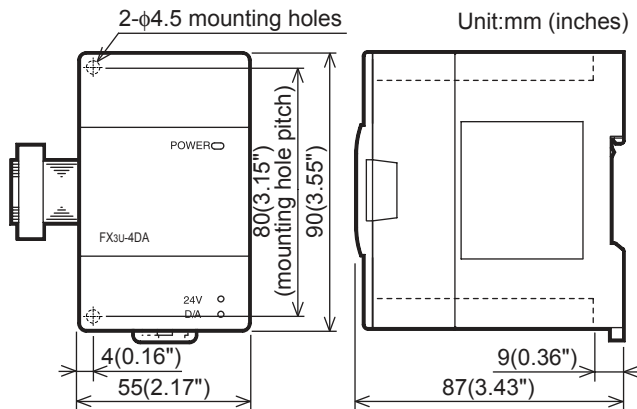

- MASS(Weight): 0.2kg (0.44lbs)
- Installation: 35 mm (1.38") wide DIN rail or screws
- Accessories: Label for indication of special unit/block number, Dust Proof sheet, Manual supplied with product
- Terminal block: M3 screws
- The extension cable is already connected to the extension block

Terminal Layout

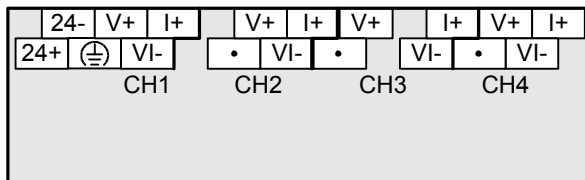

18.1.6 FX2N-4AD

External Dimensions

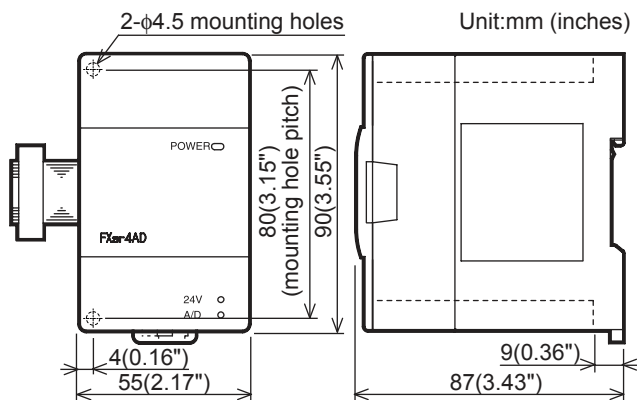

- MASS(Weight): 0.3kg (0.66lbs)
- Installation: 35 mm (1.38") wide DIN rail or screws
- Accessories: Label for indication of special unit/block number, Manual supplied with product
- Terminal block: M3 screws
- The extension cable is already connected to the extension block

Terminal Layout

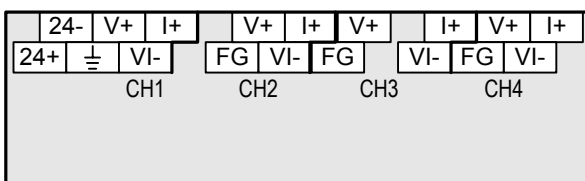

18.1.7 FX2N-4DA

External Dimensions

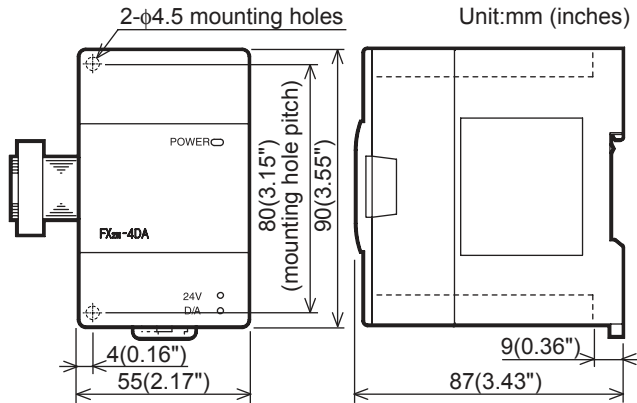

- MASS(Weight): 0.3kg (0.66lbs)
- Installation: 35 mm (1.38") wide DIN rail or screws
- Accessories: Label for indication of special unit/block number, Manual supplied with product
- Terminal block: M3 screws
- The extension cable is already connected to the extension block

Terminal Layout

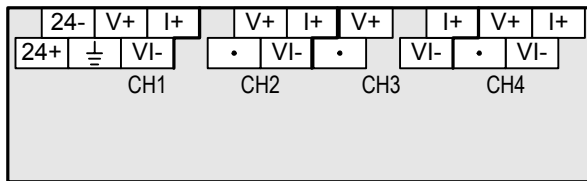

18.1.8 FX2N-4AD-PT

External Dimensions

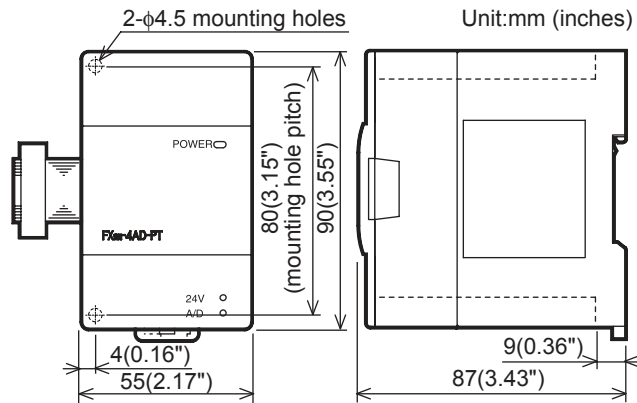

- MASS(Weight): 0.3kg (0.66lbs)
- Installation: 35 mm (1.38") wide DIN rail or screws
- Accessories: Label for indication of special unit/block number, Manual supplied with product
- Terminal block: M3 screws
- The extension cable is already connected to the extension block

Terminal Layout

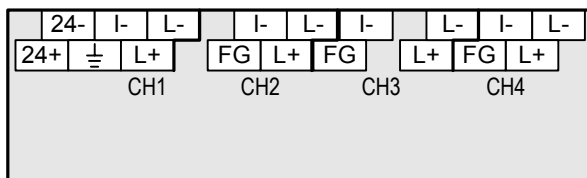

11	High-Speed Counters
12	Output Wiring
13	Wiring for Various Uses
14	Test Run, Maintenance, Troubleshooting
15	Input/Output Powered Extension Units
16	Input/Output Extension Blocks
17	Extension Power Supply Unit
18	Other Extension Units and Options
19	Display Module
20	Terminal Block

18.1.9 FX2N-4AD-TC

External Dimensions

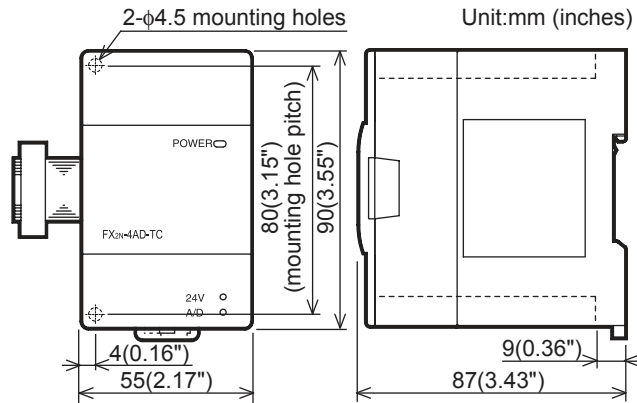

- MASS(Weight): 0.3kg (0.66lbs)
- Installation: 35 mm (1.38") wide DIN rail or screws
- Accessories: Label for indication of special unit/block number, Manual supplied with product
- Terminal block: M3 screws
- The extension cable is already connected to the extension block

Terminal Layout

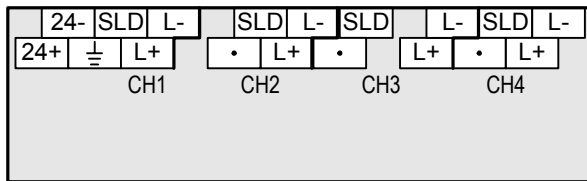

18.1.10 FX2N-5A

External Dimensions

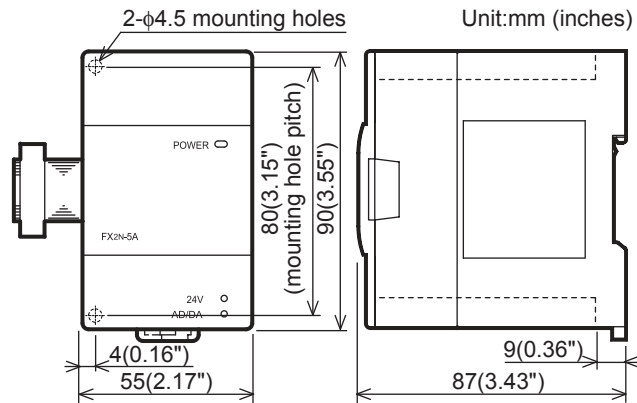

- MASS(Weight): 0.3kg (0.66lbs)
- Installation: 35 mm (1.38") wide DIN rail or screws
- Accessories: Label for indication of special unit/block number, Manual supplied with product
- Terminal block: M3 screws
- The extension cable is already connected to the extension block

Terminal Layout

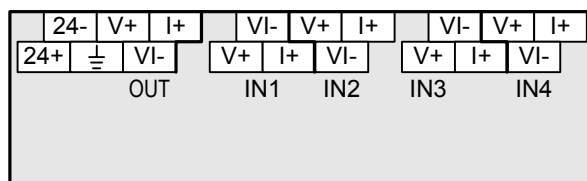

18.1.11 FX3U-4LC

External Dimensions

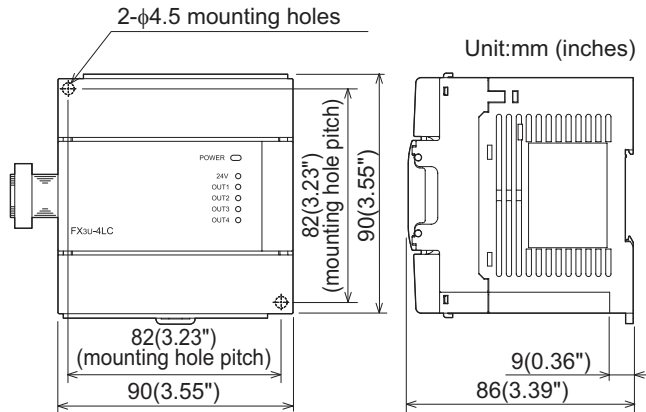

- MASS(Weight): 0.4kg (0.88lbs)
- Installation: 35mm (1.38") wide DIN rail or screws
- Accessories: Label for indication of special unit/block number, Dust proof sheet, Manual supplied with product
- Terminal block: M3 screws
- The extension cable is already connected to the extension block

Terminal Layout

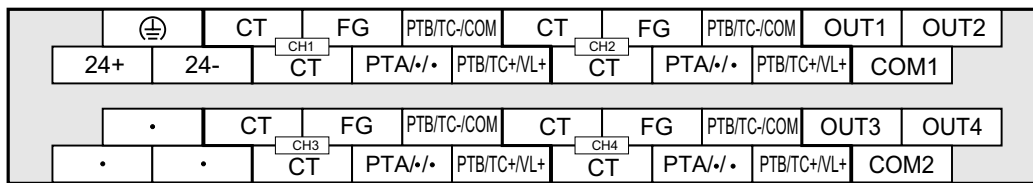

18.1.12 FX2N-2LC

External Dimensions

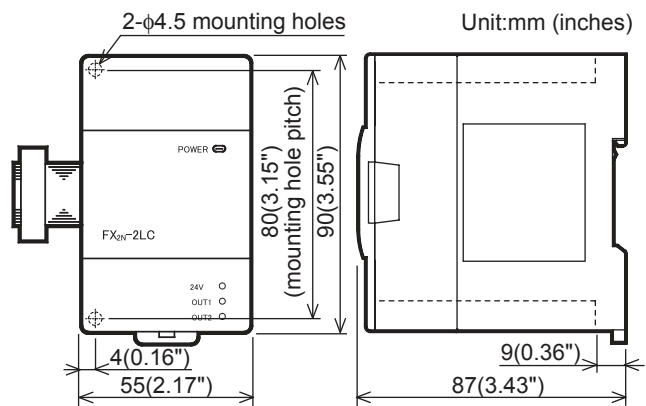

- MASS(Weight): 0.3kg (0.66lbs)
- Installation: 35mm (1.38") wide DIN rail or screws
- Accessories: Label for indication of special unit/block number, Manual supplied with product
- Terminal block: M3 screws
- The extension cable is already connected to the extension block

Terminal Layout

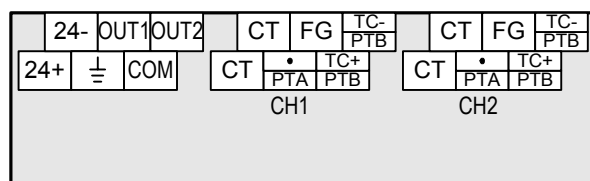

11	High-Speed Counters
12	Output Wiring
13	Wiring for Various Uses
14	Test Run, Maintenance, Troubleshooting
15	Input/Output Powered Extension Units
16	Input/Output Extension Blocks
17	Extension Power Supply Unit
18	Other Extension Units and Options
19	Display Module
20	Terminal Block

18.1.13 FX2N-8AD

External Dimensions

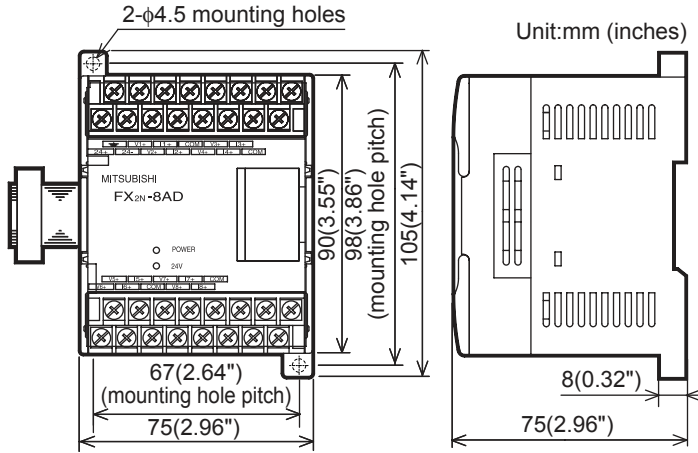

- MASS(Weight): 0.4kg (0.88lbs)
- Installation: 35mm (1.38") wide DIN rail or screws
- Accessories: Label for indication of special unit/block number, Manual supplied with product
- Terminal block: M3.5 screws
- The extension cable is already connected to the extension block

Terminal Layout

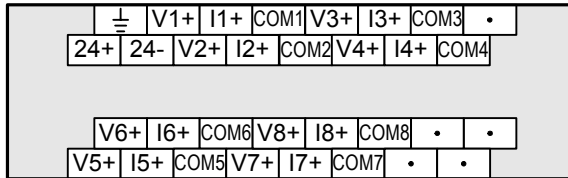

18.1.14 FX3U-2HC

External Dimensions

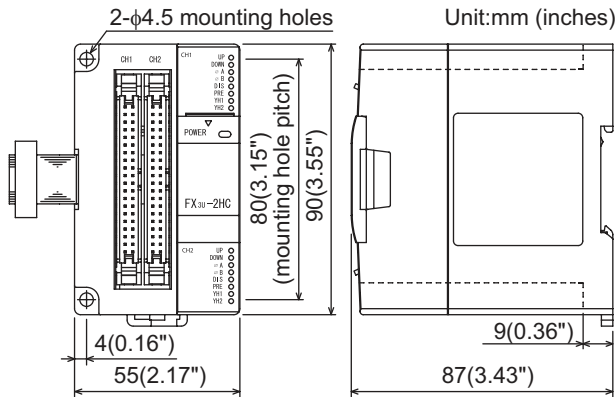

- MASS(Weight): 0.2kg (0.44lbs)
- Installation: 35mm (1.38") wide DIN rail or screws
- Accessories: Label for indication of special unit/block number, Dust proof sheet, Manual supplied with product
- Connector: 40-Pin
- The extension cable is already connected to the extension block

Terminal Layout

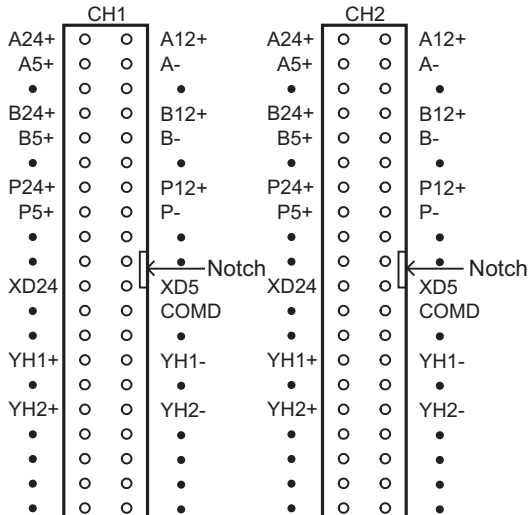

18.1.15 FX2N-1HC

External Dimensions

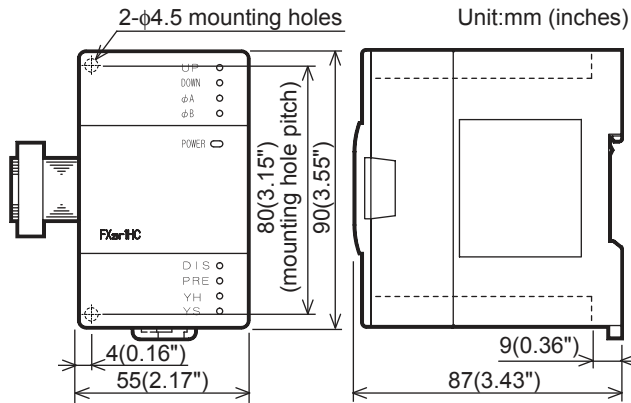

- MASS(Weight): 0.3kg (0.66lbs)
- Installation: 35mm (1.38") wide DIN rail or screws
- Accessories: Label for indication of special unit/block number, Manual supplied with product
- Terminal block: M3 screws
- The extension cable is already connected to the extension block

Terminal Layout

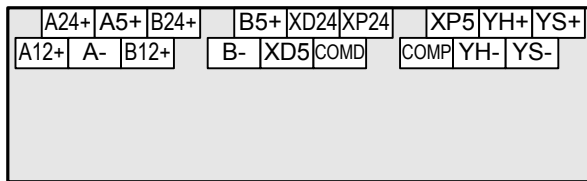

18.1.16 FX3U-20SSC-H

External Dimensions

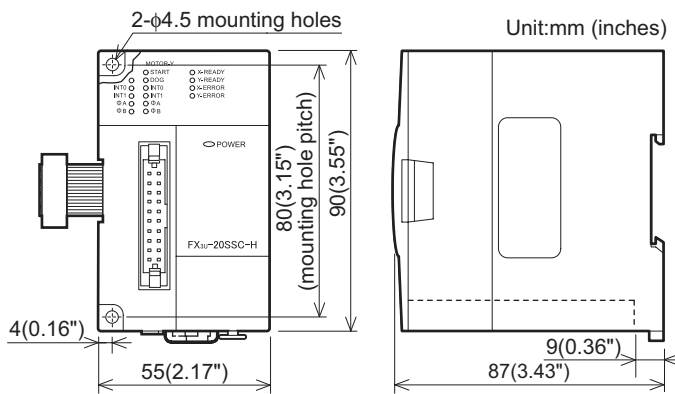

- MASS(Weight): 0.3kg (0.66lbs)
- Installation: 35mm (1.38") wide DIN rail or screws
- Accessories: Label for indication of special unit/block number, Dust Proof sheet, FX2NC-100MPCB Power supply cable (1m (3'3")), Manual supplied with product
- Connector: 20-Pin
- The extension cable is already connected to the extension block

Terminal Layout

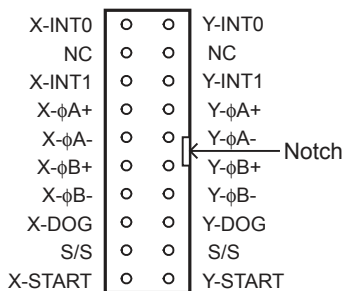

11 High-Speed Counters

12 Output Wiring

13 Wiring for Various Uses

14 Test Run, Maintenance, Troubleshooting

15 Input/Output Powered Extension Units

16 Input/Output Blocks

17 Extension Power Supply Unit

18 Other Extension Units and Options

19 Display Module

20 Terminal Block

18.1.17 FX2N-1PG(-E)

External Dimensions

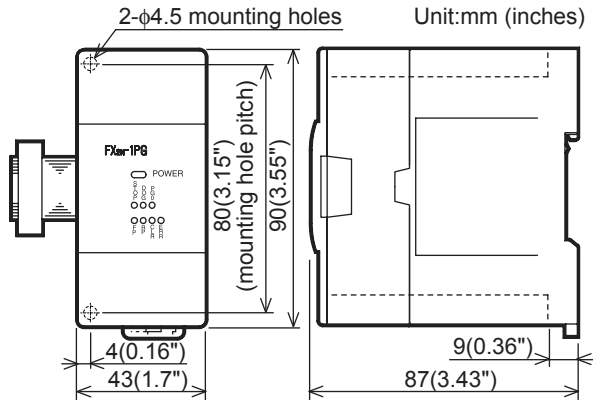

- installation: 35mm (1.38") wide DIN rail or screws
- Accessories: Label for indication of special unit/block number, Manual supplied with product
- Terminal block: M3 screws
- The extension cable is already connected to the extension block

Terminal Layout

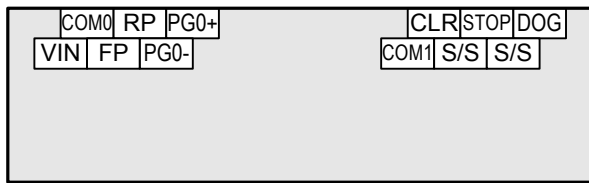

18.1.18 FX2N-10PG

External Dimensions

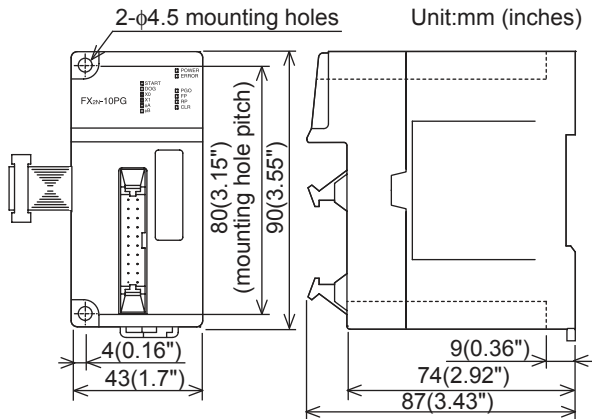

- MASS(Weight):0.2kg (0.44lbs)
- Installation: 35mm (1.38") wide DIN rail or screws
- Accessories: Label for indication of special unit/block number, Manual supplied with product
- Connector: 20-Pin
- The extension cable is already connected to the extension block

Terminal Layout

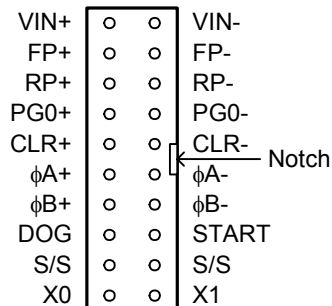

18.1.19 FX2N-10GM

External Dimensions

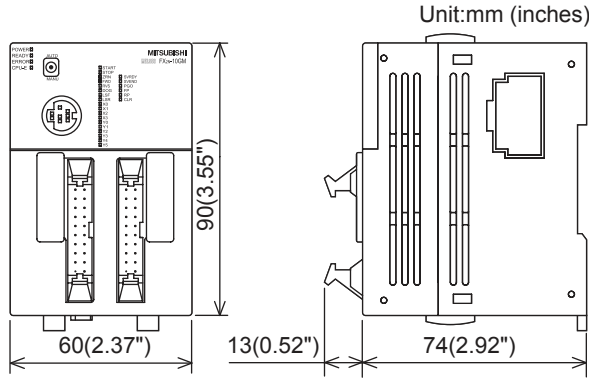

- MASS(Weight): 0.3kg (0.66lbs)
- Installation: 35mm (1.38") wide DIN rail only can be used for installation
- Accessories: FX2NC-100MPCB power cable, FX2N-GM-5EC extension cable, label for indication of special unit/block number, Manual supplied with product
- Connector: 20-Pin

Terminal Layout

CON1		CON2			
START	○ ○	X0	SVRDY	○ ○	SVEND
STOP	○ ○	X1	COM2	○ ○	COM2
ZRN	○ ○	X2	CLR	○ ○	PG0
FWD	○ ○	X3	COM3	○ ○	COM4
RVS	○ ○	Y0	•	○ ○	•
DOG	○ ○	Y1	FP	○ ○	RP ← Notch
LSF	○ ○	Y2	VIN	○ ○	VIN
LSR	○ ○	Y3	VIN	○ ○	VIN
COM1	○ ○	COM1	COM5	○ ○	COM5
Y4	○ ○	Y5	ST1	○ ○	ST2

18.1.20 FX2N-20GM

External Dimensions

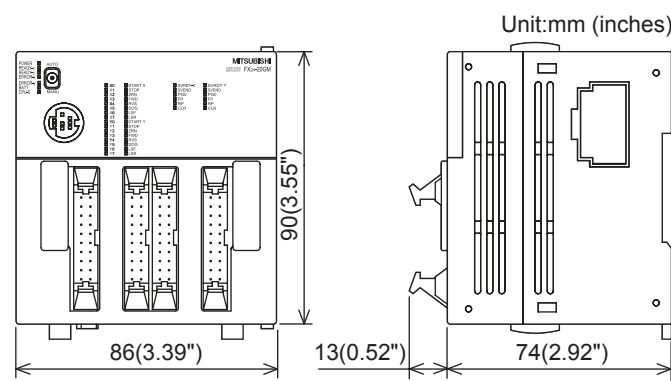

- MASS(Weight): 0.4kg (0.88lbs)
- Installation: 35mm (1.38") wide DIN rail only can be used for installation
- Accessories: FX2NC-100MPCB power cable, FX2NC-100BPCB power cable, FX2N-GM-5EC extension cable, label for indication of special unit/block number, Manual supplied with product
- Connector: 20-Pin

Terminal Layout

CON1		Y axis	CON2		X axis	CON3 (X axis)		CON4 (Y axis)			
Y00	○ ○	X00	START	○ ○	START	SVRDY	○ ○	SVEND	SVRDY	○ ○	SVEND
Y01	○ ○	X01	STOP	○ ○	STOP	COM2	○ ○	COM2	COM6	○ ○	COM6
Y02	○ ○	X02	ZRN	○ ○	ZRN	CLR	○ ○	PG0	CLR	○ ○	PG0
Y03	○ ○	X03	FWD	○ ○	FWD	COM3	○ ○	COM4	COM7	○ ○	COM8
Y04	○ ○	X04	RVS	○ ○	RVS	•	○ ○	•	•	○ ○	•
Y05	○ ○	X05	DOG	○ ○	DOG	FP	○ ○	RP	FP	○ ○	RP ← Notch
Y06	○ ○	X06	LSF	○ ○	LSF	VIN	○ ○	VIN	VIN	○ ○	VIN
Y07	○ ○	X07	LSR	○ ○	LSR	VIN	○ ○	VIN	VIN	○ ○	VIN
COM1	○ ○	COM1	COM1	○ ○	COM1	COM5	○ ○	COM5	COM9	○ ○	COM9
•	○ ○	•	•	○ ○	•	ST1	○ ○	ST2	ST3	○ ○	ST4

11 High-Speed Counters
12 Output Wiring
13 Wiring for Various Uses
14 Test Run, Maintenance, Troubleshooting
15 Input/Output Powered Extension Units
16 Input/Output Extension Blocks
17 Extension Power Supply Unit
18 Other Extension Units and Options
19 Display Module
20 Terminal Block

18.1.21 FX2N-1RM(-E)-SET

External Dimensions

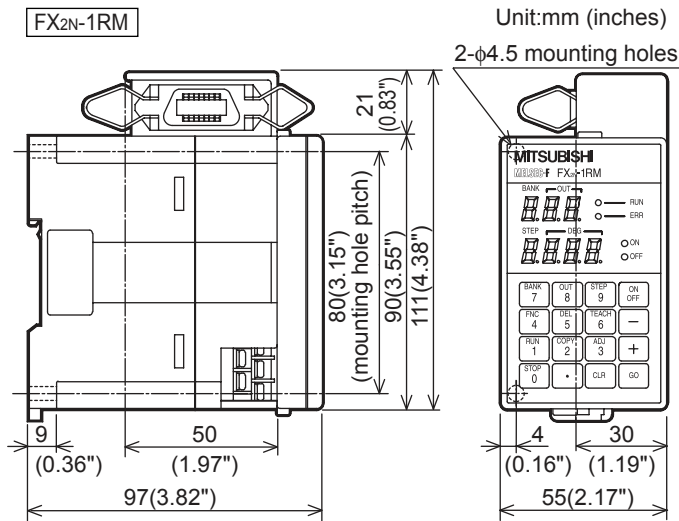

- MASS(Weight): 0.5kg (1.1lbs)
- Installation: 35mm (1.38") wide DIN rail or screws
- Accessories: FX2N-RS-5CAB signal cable (5m(16'4")), F2-720RSV resolver, extension cable (55mm(2.06")), label for indication of special unit/block number, Manual supplied with product
- Terminal block: M3 screws

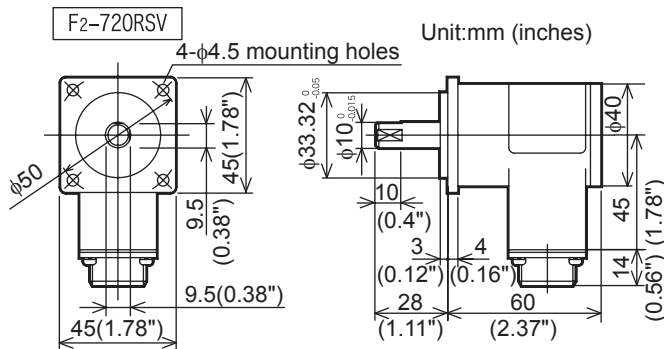

Terminal Layout

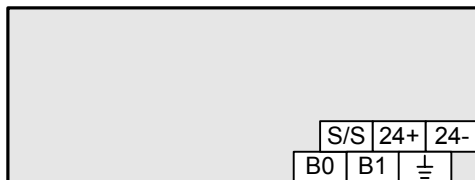

18.1.22 FX2N-232IF

External Dimensions

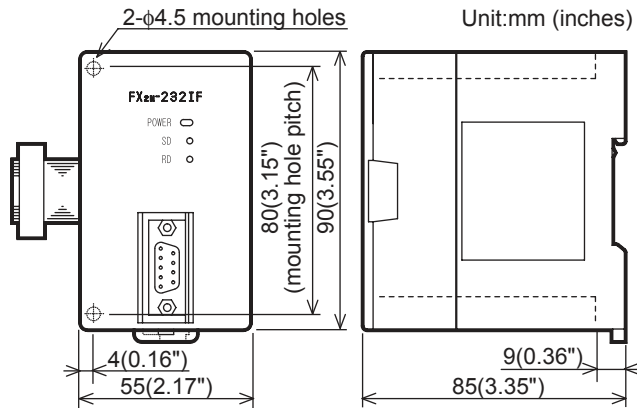

- MASS(Weight): 0.3kg (0.66lbs)
- Installation: 35mm (1.38") wide DIN rail or screws
- Accessories: Label for indication of special unit/block number, Manual supplied with product
- Connector: RS-232C (D-SUB 9-pin, male)
- The extension cable is already connected to the extension block

Terminal Layout

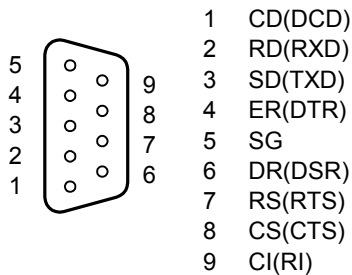

18.1.23 FX2N-32ASI-M

External Dimensions

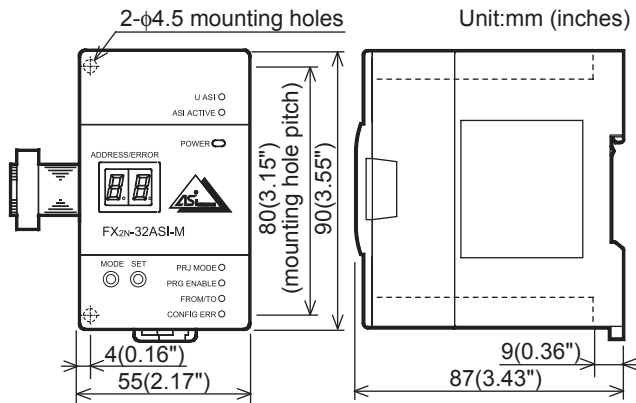

- MASS(Weight): 0.2kg (0.44lbs)
- Installation: 35mm (1.38") wide DIN rail or screws
- Accessories: Label for indication of special unit/block number, Manual supplied with product
- Terminal block: M3 screws
- The extension cable is already connected to the extension block

Terminal Layout

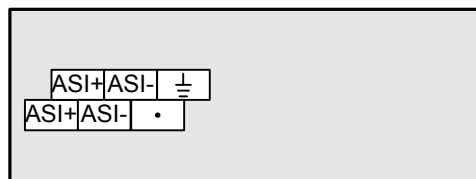

11 High-Speed Counters

12 Output Wiring

13 Wiring for Various Uses

14 Test Run, Maintenance, Troubleshooting

15 Input/Output Powered Extension Units

16 Input/Output Extension Blocks

17 Extension Power Supply Unit

18 Other Extension Units and Options

19 Display Module

20 Terminal Block

18.1.24 FX2N-64CL-M

External Dimensions

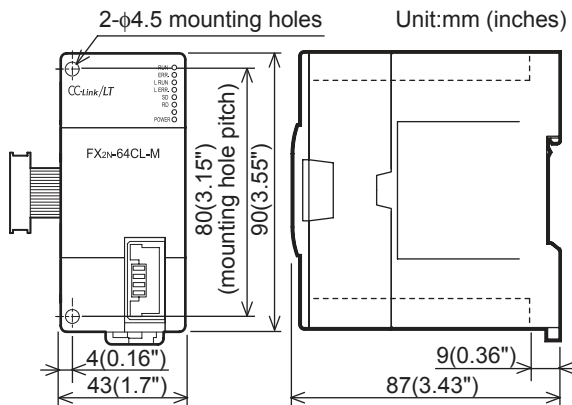

- MASS(Weight): 0.15kg (0.33lbs)
- Installation: 35mm (1.38") wide DIN rail or screws
- Accessories: Label for indication of special unit/block number, Manual supplied with product
- The connector for CC-Link/LT interface is on the front face of the product
- The extension cable is already connected to the extension block

18.1.25 FX3U-16CCL-M

External Dimensions

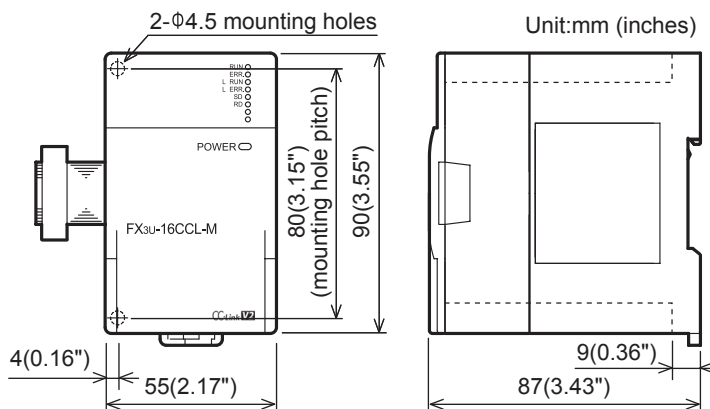

- MASS(Weight): 0.3kg (0.66lbs)
- Installation: 35mm (1.38") wide DIN rail or screws
- Accessories: Label for indication of special unit/block number, Terminal resistor: 2 resistors for CC-Link dedicated cable/2 resistors for CC-Link dedicated high-performance cable, Dust Proof sheet, Manual supplied with product
- Terminal block: M3 screws for power supply terminal, CC-Link connection terminal, M3.5 screws for CC-Link connection terminal block mounting screws (black)
- The extension cable is already connected to the extension block

Terminal Layout

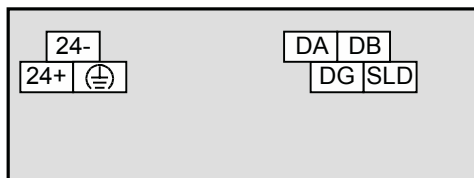

18.1.26 FX2N-16CCL-M

External Dimensions

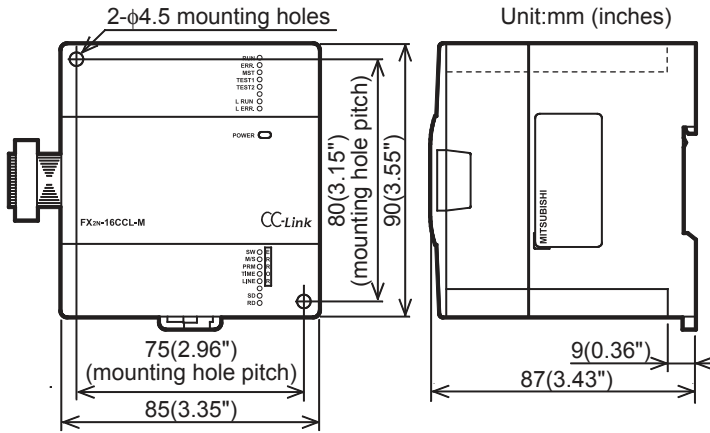

- MASS(Weight): 0.4kg (0.88lbs)
- Installation: 35mm (1.38") wide DIN rail or screws
- Accessories: Label for indication of special unit/block number, Terminal resistor: 2 resistors for CC-Link dedicated cable/2 resistors for CC-Link dedicated high-performance cable, Manual supplied with product
- Terminal block: M3 screw for power supply terminal, M3.5 screw for signal terminal
- The extension cable is already connected to the extension block

Terminal Layout

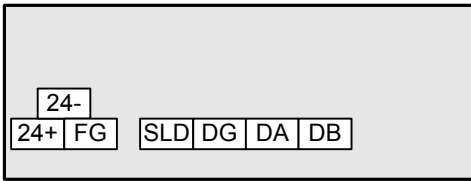

18.1.27 FX2N-32CCL

External Dimensions

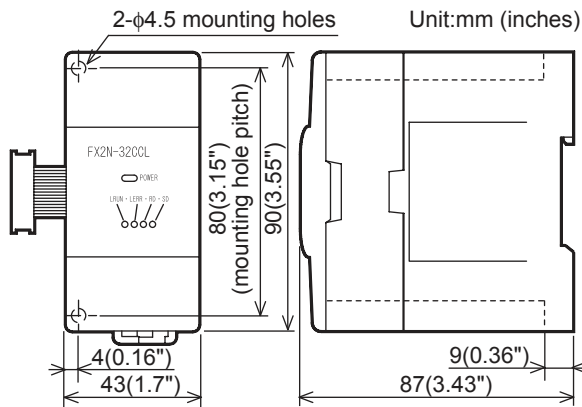

- MASS(Weight): 0.2kg (0.44lbs)
- Installation: 35mm (1.38") wide DIN rail or screws
- Accessories: Label for indication of special unit/block number, Manual supplied with product
- Terminal block: M3 screws
- The extension cable is already connected to the extension block

Terminal Layout



11 High-Speed Counters

12 Output Wiring

13 Wiring for Various Uses

14 Test Run, Maintenance, Troubleshooting

15 Input/Output Powered Extension Units

16 Input/Output Extension Blocks

17 Extension Power Supply Unit

18 Other Extension Units and Options

19 Display Module

20 Terminal Block

18.1.28 FX3U-64CCL

External Dimensions

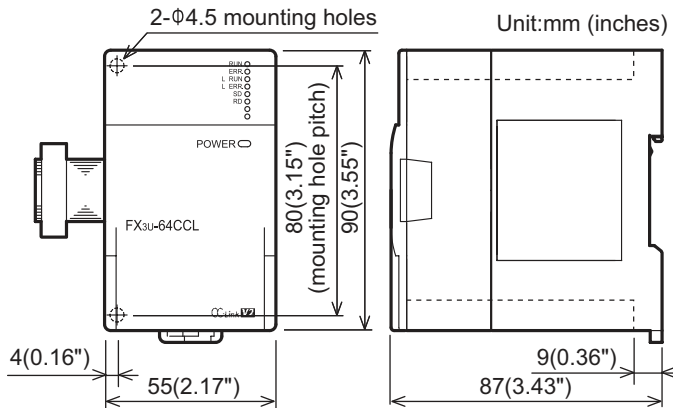

- MASS(Weight): 0.3kg (0.66lbs)
- Installation: 35mm (1.38") wide DIN rail or screws
- Accessories: Label for indication of special unit/block number, Dust Proof sheet, Manual supplied with product
- Terminal block: M3 screws for power supply terminal, CC-Link connection terminal, M3.5 screws for CC-Link connection terminal block mounting screws (black)
- The extension cable is already connected to the extension block

Terminal Layout

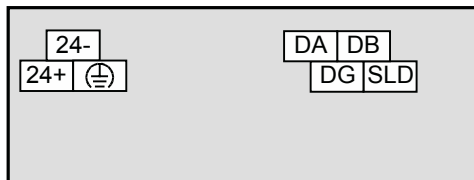

18.1.29 FX2N-16LNK-M

External Dimensions

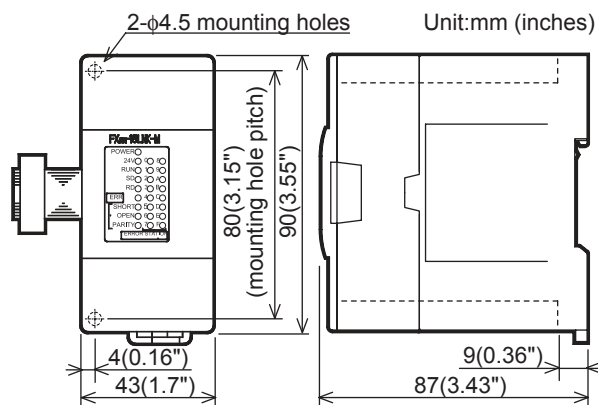

- Installation: 35mm (1.38") wide DIN rail or screws
- Accessories: Label for indication of special unit/block number, Manual supplied with product
- Terminal block: M3 screws
- The extension cable is already connected to the extension block

Terminal Layout



18.2 Extension Power Supply Unit

18.2.1 FX3U-1PSU-5V

External Dimensions

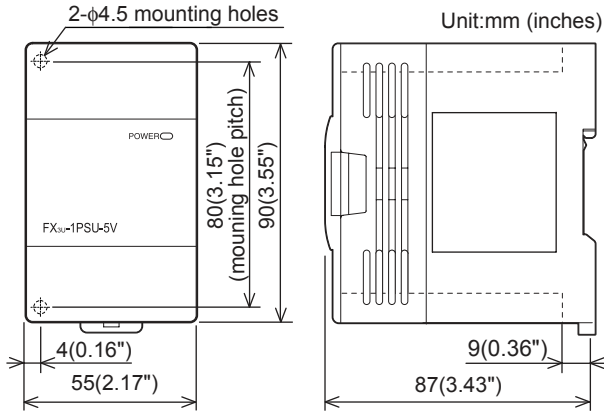

- MASS(Weight): 0.3kg (0.66lbs)
- Installation: 35mm (1.38") wide DIN rail or screws
- Accessories: Extension cable (55mm (2.16")), Dust Proof sheet, Manual supplied with product
- Terminal block: M3 screws

Terminal Layout



18.3 Special Adapters

18.3.1 FX3U-4AD-ADP

External Dimensions, Terminal Layout

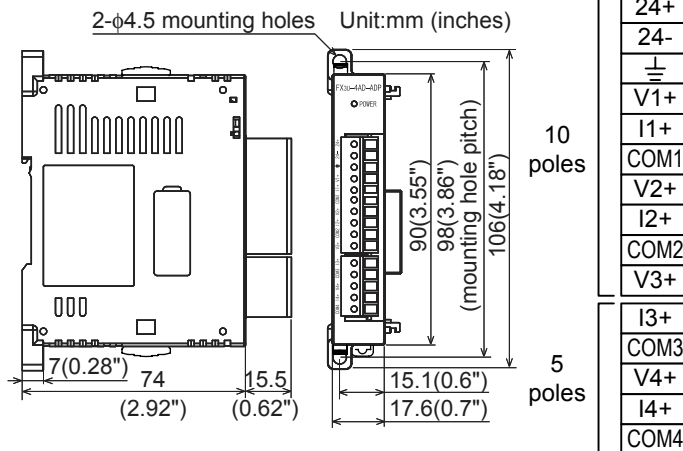

- MASS(Weight): 0.1kg (0.22lbs)
- Installation: 35 mm (1.38") wide DIN rail or screws
- Accessories: Manual supplied with product
- Terminal block: European type

11	High-Speed Counters
12	Output Wiring
13	Wiring for Various Uses
14	Test Run, Maintenance, Troubleshooting
15	Input/Output Powered Extension Units
16	Input/Output Extension Blocks
17	Extension Power Supply Unit
18	Other Extension Units and Options
19	Display Module
20	Terminal Block

18.3.2 FX3U-4DA-ADP

External Dimensions, Terminal Layout

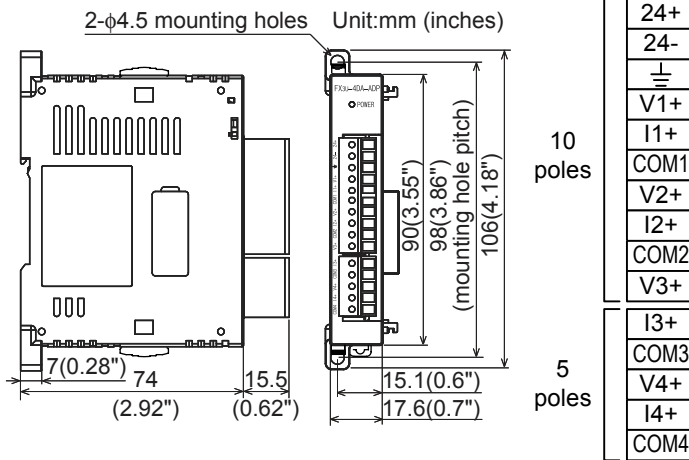

- MASS(Weight): 0.1kg (0.22lbs)
- Installation: 35 mm (1.38") wide DIN rail or screws
- Accessories: Manual supplied with product
- Terminal block: European type

18.3.3 FX3U-3A-ADP

External Dimensions, Terminal Layout

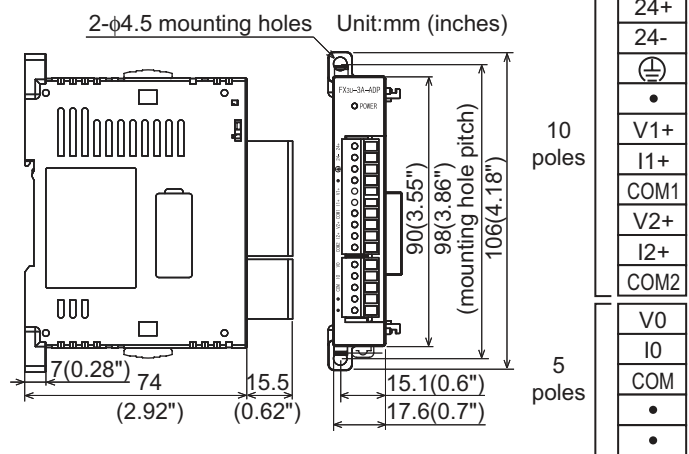

- MASS(Weight): 0.1kg (0.22lbs)
- Installation: 35 mm (1.38") wide DIN rail or screws
- Accessories: Manual supplied with product
- Terminal block: European type

18.3.4 FX3U-4AD-PT(W)-ADP

External Dimensions, Terminal Layout

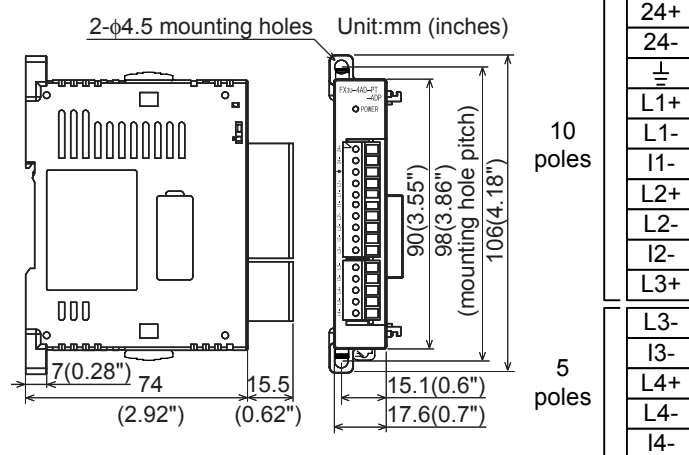

- MASS(Weight): 0.1kg (0.22lbs)
- Installation: 35 mm (1.38") wide DIN rail or screws
- Accessories: Manual supplied with product
- Terminal block: European type

18.3.5 FX3U-4AD-PNK-ADP

External Dimensions, Terminal Layout

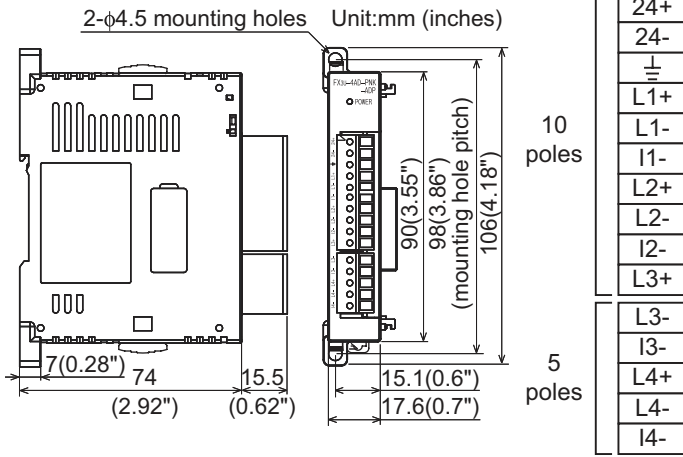

- MASS(Weight): 0.1kg (0.22lbs)
- Installation: 35 mm (1.38") wide DIN rail or screws
- Accessories: Manual supplied with product
- Terminal block: European type

18.3.6 FX3U-4AD-TC-ADP

External Dimensions, Terminal Layout

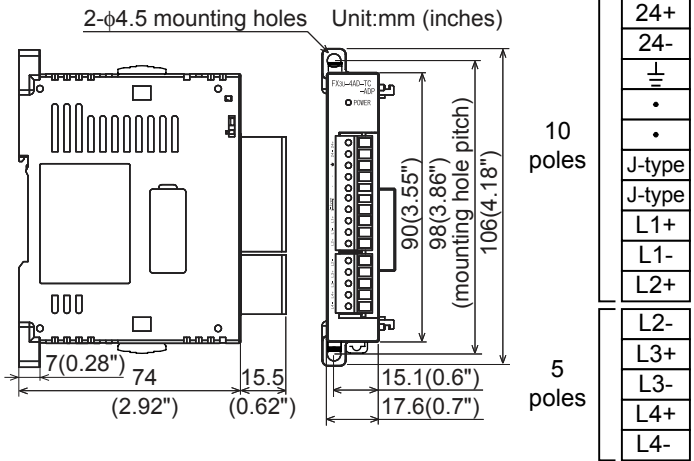

- MASS(Weight): 0.1kg (0.22lbs)
- Installation: 35 mm (1.38") wide DIN rail or screws
- Accessories: Manual supplied with product
- Terminal block: European type

11 High-Speed Counters

12 Output Wiring

13 Wiring for Various Uses

14 Test Run, Maintenance, Troubleshooting

15 Input/Output Powered Extension Units

16 Input/Output Extension Blocks

17 Extension Power Supply Unit

18 Other Extension Units and Options

19 Display Module

20 Terminal Block

18.3.7 FX3U-232ADP(-MB)

External Dimensions

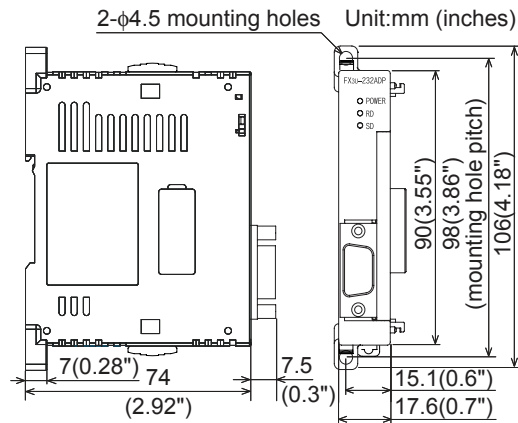

- MASS(Weight): 80g (0.18lbs)
- Installation: 35 mm (1.38") wide DIN rail or screws
- Accessories: Manual supplied with product
- Connector: RS-232C (D-SUB 9-pin, male)

Terminal Layout

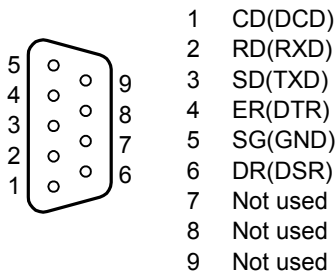

18.3.8 FX3U-485ADP(-MB)

External Dimensions

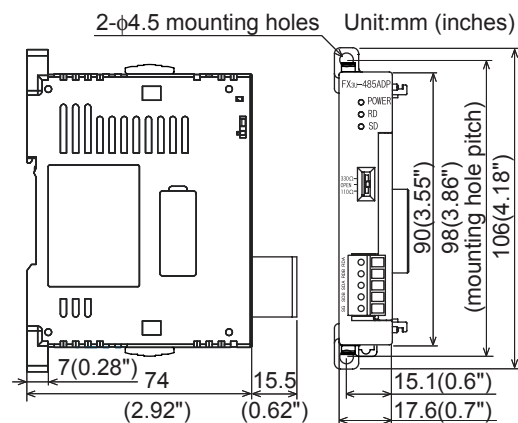

- MASS(Weight): 80g (0.18lbs)
- Installation: 35 mm (1.38") wide DIN rail or screws
- Accessories: Label for indication of link station number, Manual supplied with product
- Terminal block: European type
- Terminal resistance: 330Ω/110Ω, built-in

Terminal Layout

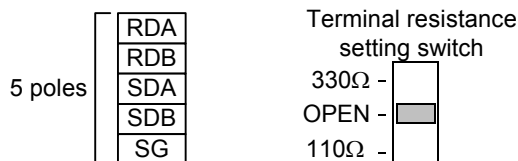

18.3.9 FX3U-CF-ADP

External Dimensions, Terminal Layout

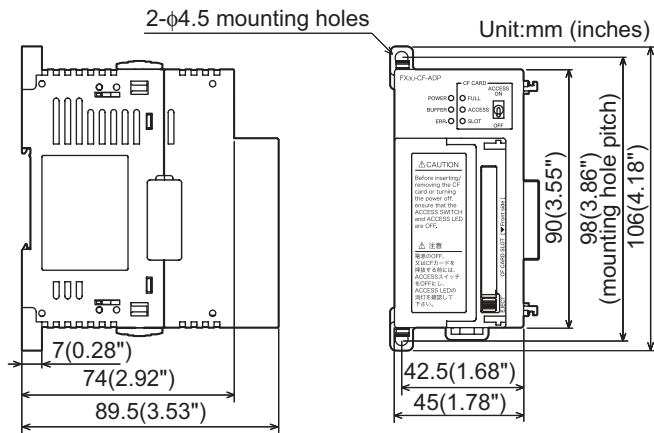

- MASS(Weight): 0.3kg (0.66lbs)
(CF card not attached)
- Installation: 35 mm (1.38") wide DIN rail or screws
- Accessories: FX2NC-100MPCB Power supply cable [1m(3'3")]
Dust proof protection sheet
Manual supplied with product

18.3.10 FX3U-4HSX-ADP

External Dimensions, Terminal Layout

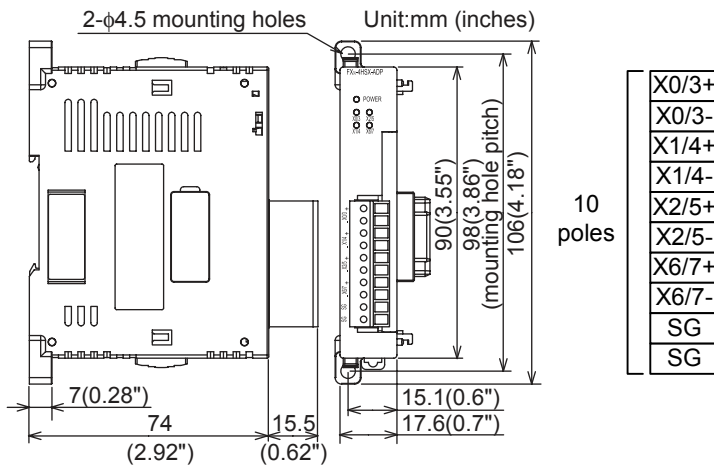

- MASS(Weight): 80g (0.18lbs)
- Installation: 35 mm (1.38") wide DIN rail or screws
- Accessories: Manual supplied with product
- Terminal block: European type

18.3.11 FX3U-2HSY-ADP

External Dimensions, Terminal Layout

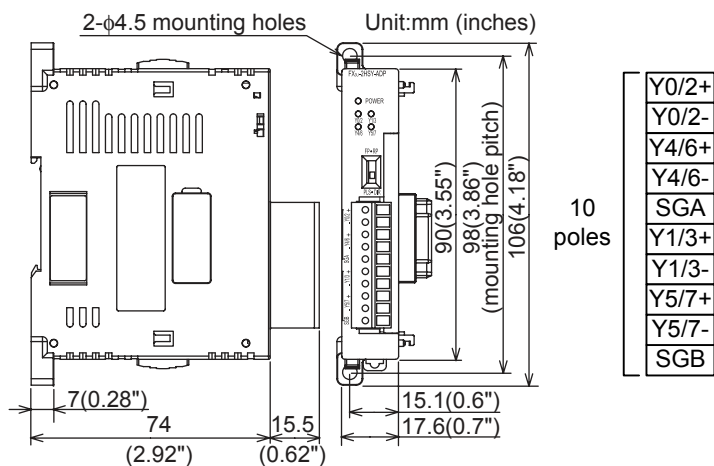

- MASS(Weight): 80g (0.18lbs)
- Installation: 35 mm (1.38") wide DIN rail or screws
- Accessories: Manual supplied with product
- Terminal block: European type
- Switch: Output form switching between PLS•EDIR and FP•ERP

11 High-Speed Counters

12 Output Wiring

13 Wiring for Various Uses

14 Test Run, Maintenance, Troubleshooting

15 Input/Output Powered Extension Units

16 Input/Output Blocks

17 Extension Power Supply Unit

18 Other Extension Units and Options

19 Display Module

20 Terminal Block

18.4 Expansion Board

18.4.1 FX3U-USB-BD

External Dimensions

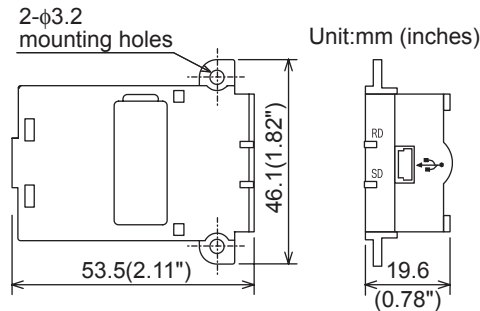

- MASS(Weight): 20g (0.05lbs)
- Accessories: Two M3 tapping screws (for installation of board), USB driver software (CD-ROM), USB cable (3m(9'10")), Manual supplied with product
- Connector: USB (MINI B connector, female)

18.4.2 FX3U-232-BD

External Dimensions

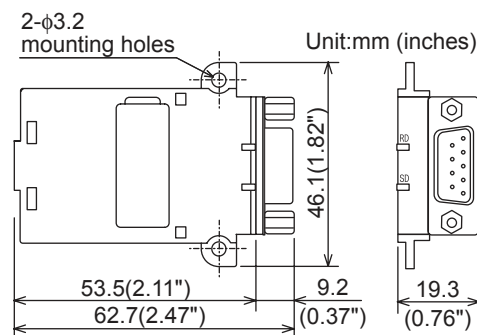

- MASS(Weight): 20g (0.05lbs)
- Accessories: Two M3 tapping screws (for installation of board), Manual supplied with product
- Connector: RS-232C (D-SUB 9-pin, male)

Terminal Layout

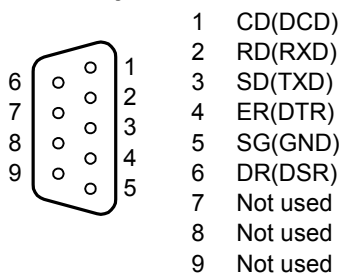

18.4.3 FX3U-422-BD

External Dimensions

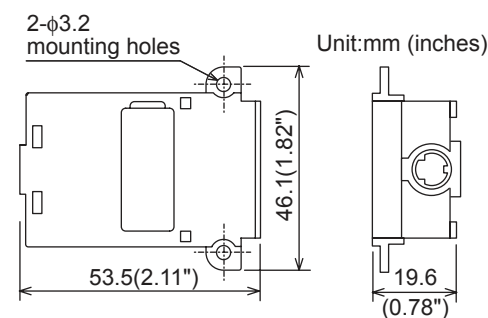

- MASS(Weight): 20g (0.05lbs)
- Accessories: Two M3 tapping screws (for installation of board), Manual supplied with product
- Connector: RS-422 (MINI DIN 8-pin, female)

18.4.4 FX3U-485-BD

External Dimensions

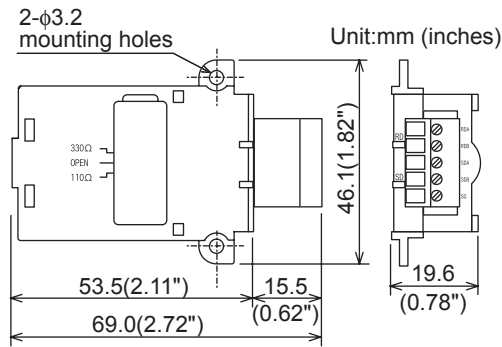

Terminal Layout

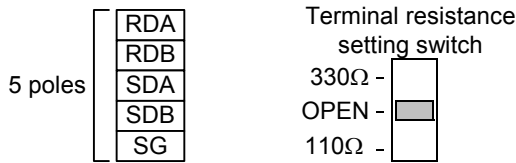

- MASS(Weight): 20g (0.05lbs)
- Accessories: Two M3 tapping screws (for installation of board), Label for indication of link station number, Manual supplied with product
- Terminal block: European type
- Terminal resistance: 330Ω/110Ω, built-in

18.4.5 FX3U-8AV-BD

External Dimensions

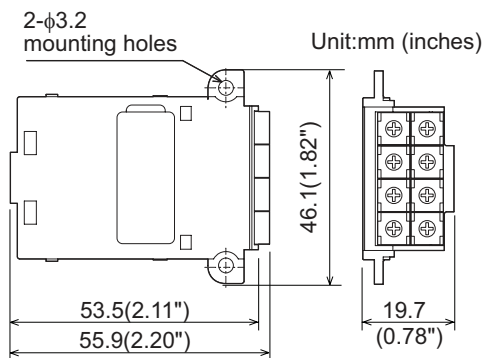

Trimmer Layout



- MASS(Weight): 20g (0.05lbs)
- Accessories: Two M3 tapping screws (for installation of board), Trimmer layout label, Manual supplied with product

18.4.6 FX3U-CNV-BD

External Dimensions

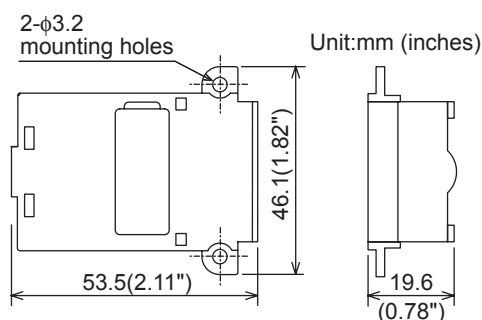

- MASS(Weight): 10g (0.03lbs)
- Accessories: Two M3 tapping screws (for installation of board), Manual supplied with product

11	High-Speed Counters
12	Output Wiring
13	Wiring for Various Uses
14	Test Run, Maintenance, Troubleshooting
15	Input/Output Powered Extension Units
16	Input/Output Extension Blocks
17	Extension Power Supply Unit
18	Other Extension Units and Options
19	Display Module
20	Terminal Block

18.5 Power Supply

18.5.1 FX2N-20PSU

External Dimensions

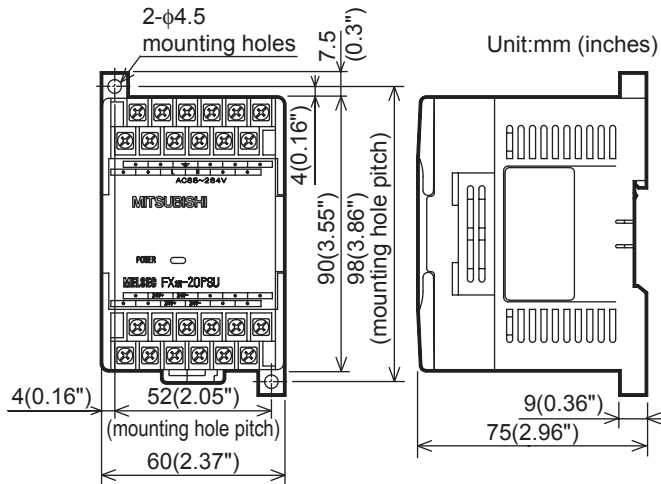

- MASS(Weight): 0.3kg (0.66lbs)
- Installation: 35 mm (1.38") wide DIN rail or screws
- Accessories: Manual supplied with product
- Terminal block: M3.5 screws

Terminal Layout

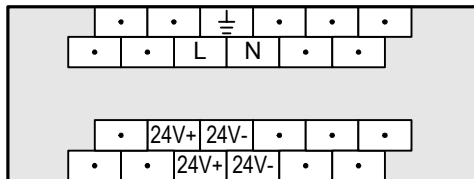

18.6 Connector Conversion Adapter

18.6.1 FX2N-CNV-BC

External Dimensions

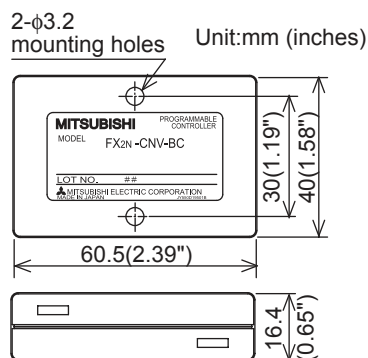

- MASS(Weight): 40g (0.09lbs)
- Installation: Screws only

18.7 Interface Module

18.7.1 FX-232AWC-H

External Dimensions

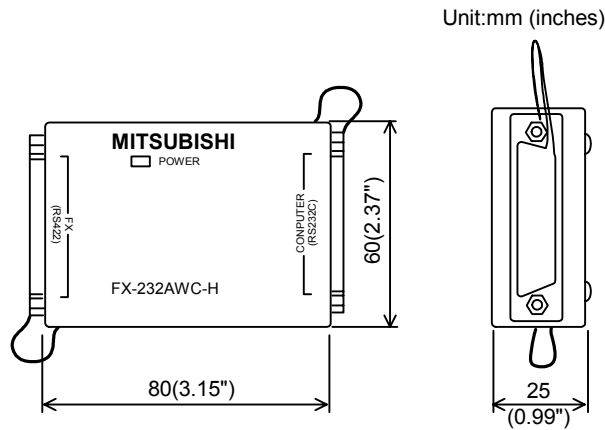

- MASS(Weight): 0.1kg (0.22lbs)
- Accessories: Manual supplied with product
- Connector: RS-232C (D-SUB 25-pin, female)
RS-422 (D-SUB 25-pin, female)

18.7.2 FX-USB-AW

External Dimensions

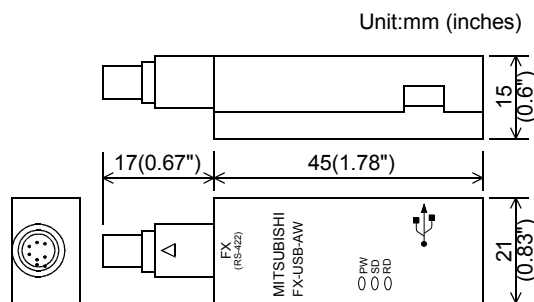

- MASS(Weight): 20g (0.05lbs)
- Accessories: USB driver software (CD-ROM), USB cable (3m(9'10")), Manual supplied with product
- Connector: RS-422 (MINI DIN 8-pin, male)
USB (MINI B connector, female)

11	High-Speed Counters
12	Output Wiring
13	Wiring for Various Uses
14	Test Run, Maintenance, Troubleshooting
15	Input/Output Powered Extension Units
16	Input/Output Extension Blocks
17	Extension Power Supply Unit
18	Other Extension Units and Options
19	Display Module
20	Terminal Block

18.8 Display Module

18.8.1 FX3U-7DM

External Dimensions

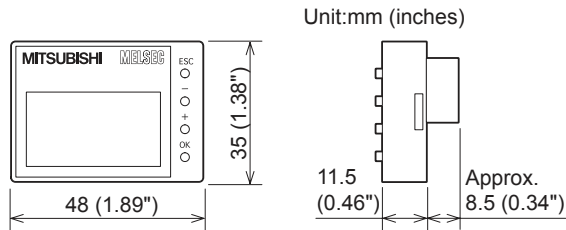

- MASS(Weight): 20g (0.05lbs)
- Accessories: Display module mounting top cover,
Manual supplied with product

18.8.2 FX3U-7DM-HLD

External Dimensions

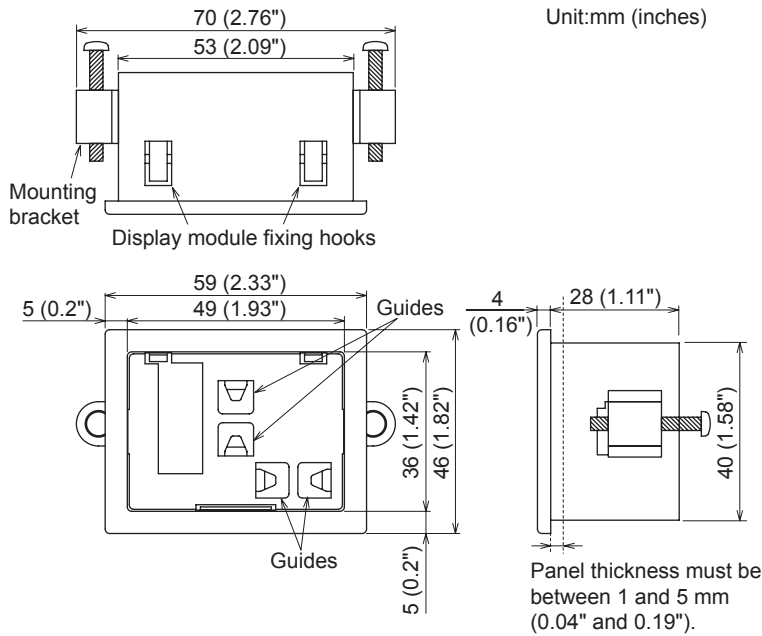

- MASS(Weight): 20g (0.05lbs)
- Accessories: PLC cover,
Mounting bracket × 2 pieces,
Tightening bolt (M4 × 25) × 2 pieces,
Extension cable with ferrite core (1.4m(4'7")),
Clamp A × 5 pieces,
Clamp B × 1 piece,
Cable tie × 1 piece,
Manual supplied with product

19. FX3U-7DM (Display Module)

STARTUP AND MAINTENANCE PRECAUTIONS



- Do not touch any terminal while the PLC's power is on. Doing so may cause electric shock or malfunctions.
- Before cleaning or retightening terminals, cut off all phases of the power supply externally. Failure to do so may cause electric shock.
- Before modifying or disrupting the program in operation or running the PLC, carefully read through this manual and the associated manuals and ensure the safety of the operation. An operation error may damage the machinery or cause accidents.
- Do not change the program in the PLC from two or more peripheral equipment devices at the same time. (i.e. from a programming tool and a GOT)
Doing so may cause destruction or malfunction of the PLC program.

STARTUP AND MAINTENANCE PRECAUTIONS



- Turn off the power to the PLC before attaching or detaching the memory cassette. If the memory cassette is attached or detached while the PLC's power is on, the data in the memory may be destroyed, or the memory cassette may be damaged.
- Do not disassemble or modify the PLC. Doing so may cause fire, equipment failures, or malfunctions. For repair, contact your local Mitsubishi Electric representative.
- Turn off the power to the PLC before connecting or disconnecting any extension cable. Failure to do so may cause equipment failures or malfunctions.
- Turn off the power to the PLC before attaching or detaching the following devices. Failure to do so may cause equipment failures or malfunctions.
 - Peripheral devices, display module, expansion boards, and special adapters
 - Extension units/blocks and FX Series terminal blocks
 - Battery and memory cassette

11	High-Speed Counters
12	Output Wiring
13	Wiring for Various Uses
14	Test Run, Maintenance, Troubleshooting
15	Input/Output Powered Extension Units
16	Input/Output Extension Blocks
17	Extension Power Supply Unit
18	Other Extension Units and Options
19	Display Module
20	Terminal Block

19.1 Description of Products (Introduction of Related Products)

The FX3U-7DM display module can be incorporated in the main unit, or can be installed in the enclosure using the FX3U-7DM-HLD display module holder.

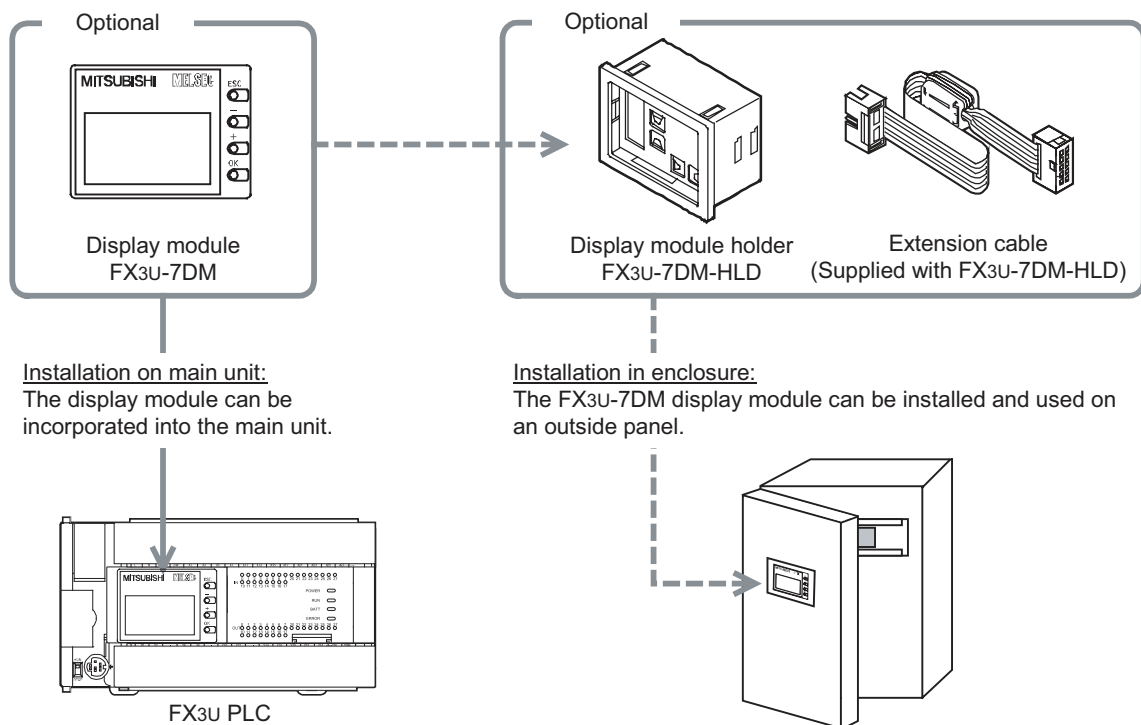

For a detailed description of the display module holder, refer to the "FX3U-7DM-HLD User's Manual".

19.2 Specifications

19.2.1 Display/switch specifications

Item		Description
Display device/ backlight		STN monochrome liquid crystal display/Backlight: LED (green)
Displaed letters	Number of letters	16 letters × 4 lines (2 byte letters: 8 letters × 4 lines)
	Characters	English Alphabet, Numbers, Japanese Characters, Shift JIS Level-1, 2
	Language for menu display	Japanese/English
Button		4 operation buttons (OK, ESC, +, and -)

Notes for displaying symbols(ASCII Code)

- ¥ (ASCII Code:5C) symbol is displayed as " ¥ " even if the language display setting at FX3u-7DM is set to English(LANGUAGE:ENGLISH).
- The Character at ASCII Code:7E "~" is not displayed.

19.2.2 Parts layout

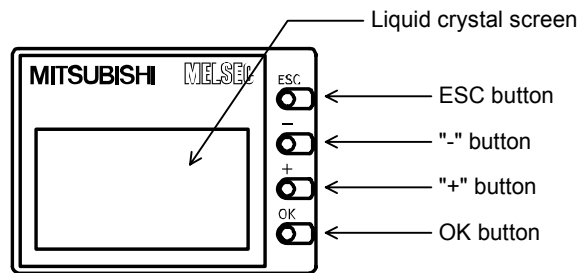

Functions of operation buttons:

The display module has 4 operation buttons as shown in the following table.

Name of button	Function of operation button
ESC	Use this button to cancel the operation and to return to the previous screen.
-	Use this button to move the cursor or to set a numeric value.
+	Use this button to move the cursor or to set a numeric value.
OK	Use this button to select an item or to determine the set numeric value.

19.2.3 External dimensions

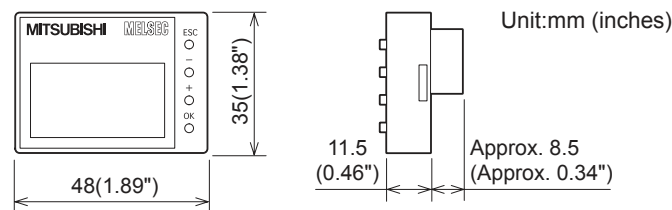

For FX3u PLC installation:

After installing the display module on the main unit, the main unit will be approximately 2.5 mm (0.1") higher than the initial height.

For the other dimensions, refer to the dimensional outline drawing of the main unit.

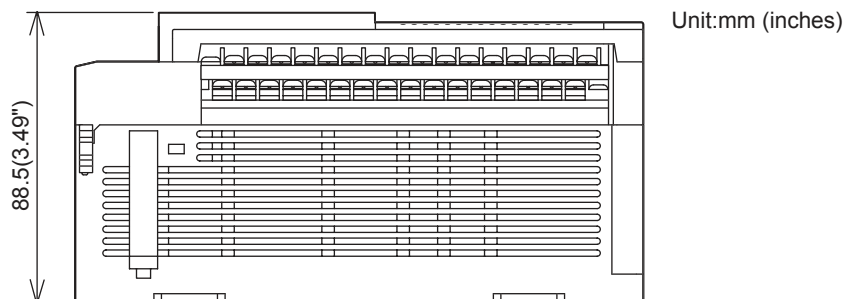

19.3 Installation and Removal

This section describes how to install and remove the display module.

1 Turn off the power of the PLC.

Before installing or removing the display module, be sure to turn off the power to the PLC.

2 Remove the top cover.

While pressing the top cover hook ("A"), remove the top cover ("B") as shown in the right figure.

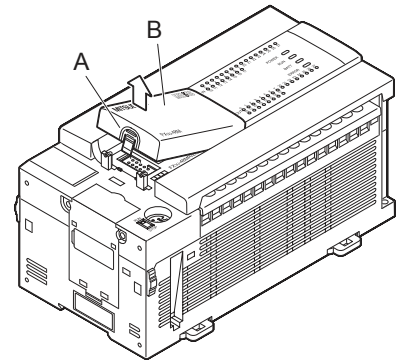

3 Install/remove the display module.

Installation: Push the display module ("C") down at position "E" shown in the lower right figure to install the display module on the main unit ("D").

Removal: Pull the display module outward ("C") to remove the display module from the main unit ("D").

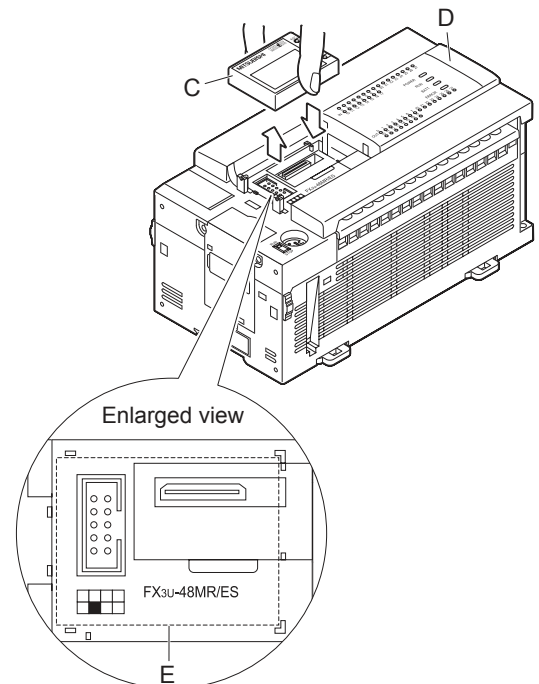

4 Attach the top cover.

Put side "G" of the display module's top cover ("F") on the main unit ("D") as shown, then push down on the top cover ("F") until it locks into place.

The top cover of the display module is supplied with the FX3U-7DM (display module).

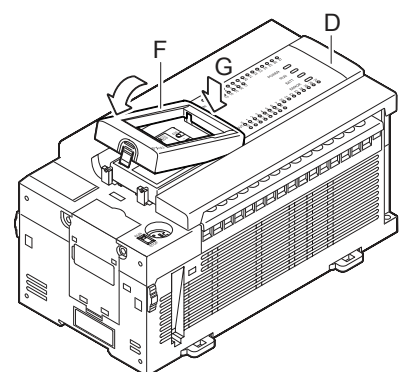

19.4 Summary of Functions

The display module functions are summarized below.

Item	Function	Remarks	Reference
Top screen (time display)	Displays the time indicated by the main unit's internal real-time clock.	Button operation	Subsection 19.5.2
Menu screen functions			
Monitor/Test	Devices	Input (X) ^{*1} , output (Y), auxiliary relay (M), state (S), timer (T), counter (C), data register (D) [16-bit/32-bit], extended register (R), and extended file register (ER) [16-bit/32-bit] monitor/test function.	Button operation Section 19.7
	User (User-registered device)	Up to 4 data registers (D) [16-bit/32-bit] can be registered.	Requires program Section 19.8 and Section 19.19
ErrorCheck	Performs error checks and displays the results.	Button operation	Section 19.9
LANGUAGE (selects the menu display language)	Selects either Japanese or English as the menu display language.	Button operation	Section 19.10
Contrast	Adjusts the contrast (-5 to 10); default setting: 0	Button operation	Section 19.11
ClockMenu (Time setting)	Setting	Sets the current time.	Button operation Subsection 19.12.1
	Display	Displays the current time.	operation Subsection 19.12.2
EntryCode	The currently specified entry code can be canceled.	Button operation	Section 19.13
ClearAllDev (Device all clear)	Initializes the Input (X) ^{*1} , output (Y), auxiliary relay (M), state (S), timer (T), counter (C), data register (D) [16-bit/32-bit], and extended register (R). The file register (D) is excluded from this function. (Bit devices are turned OFF, and word device current values are set to "0".)	Button operation	Section 19.14
PLC Status	Verifies the version information, entry code status, program memory type status, and battery voltage, etc.	Button operation	Section 19.15
ScanTime	Displays the scan time (max./min./current value)	Button operation	Section 19.16
Cassette (Memory cassette transfer)	Allows data transfers (and consistency checks) between the internal RAM and the memory cassette.	Button operation	Section 19.17
Non-menu functions			
Operation button ON/OFF information	Allows monitoring of operation button ON/OFF status.	Requires program or monitor	Section 19.20
Hexadecimal current value display setting	Changes the display format of the current values and setting values for the timer, counter, data register, extended register, and extended file register to a hexadecimal display format.	Requires program *2	Section 19.21
Display screen protect function	Enables all functions, prohibits change (test) functions, and protects the top screen (time display).	Requires program	Section 19.22
User message display	The following codes saved at the display device can be used as display commands: Alphanumeric: 20H to 7DH ASCII code Katakana: A1H to DFH ASCII code Japanese character: Shift JIS Level-1, 2	Requires program	Section 19.23

*1. There is no test function for "Input (X)".

*2. A sequence program is required to enable a hexadecimal display of the timer (T), counter (C), data register (file register) (D), extended register (R) [16-bit/32-bit], and extended file register (ER) [16-bit/32-bit] current values.
→ Refer to Section 19.21 for the setting procedure.

11	High-Speed Counters
12	Output Wiring
13	Wiring for Various Uses
14	Test Run, Maintenance, Troubleshooting
15	Input/Output Powered Extension Units
16	Input/Output Extension Blocks
17	Extension Power Supply Unit
18	Other Extension Units and Options
19	Display Module
20	Terminal Block

19.5 Procedure for Accessing the Menu Screen from the Title Screen

All operation explanations and display screen examples in this manual are in English. When the menu display language is set to Japanese, please convert the screen messages to their Japanese translations.

→ Refer to Section 19.25 for the Japanese & English display character correspondence table.

→ Refer to Section 19.10 for menu display language setting.

19.5.1 Title screen

The screen shown at right is displayed for 1.5 seconds after the power is turned on.

	Content
[1]	Model name
[2]	Version

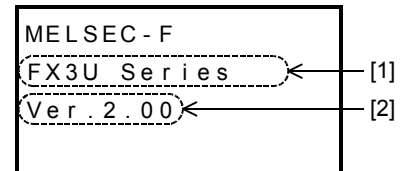

19.5.2 Top screen (time display)

Following the title screen display, the "Current Time screen" is then displayed.

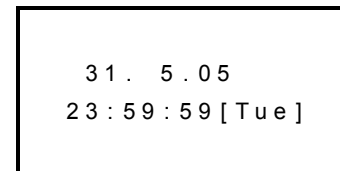

A user screen can also be displayed by using the user message display function.

→ Refer to Section 19.23 for user message display function.

Although the year displays in a 2-digit format (05), this can be changed to a 4-digit format (2005) by revising the program.

→ Refer to Subsection 19.12.3 for the 2-digit year to 4-digit year change procedure.

19.5.3 Menu screen

As shown in the figure at right, the menu screen displays 4 lines of the total menu. Press the [+] button to scroll downward through the menu.

Button operations at this menu screen are explained below.

Button	Operation Description
ESC	Returns to the "top screen" (time display).
-	Scrolls upward through the menu. Hold for 1 second or longer for high-speed scrolling. This button is disabled when the cursor is located at the beginning of the menu.
+	Scrolls downward through the menu. Hold for 1 second or longer for high-speed scrolling. This button is disabled when the cursor is located at the end of the menu.
OK	Selects the item where the cursor is blinking.

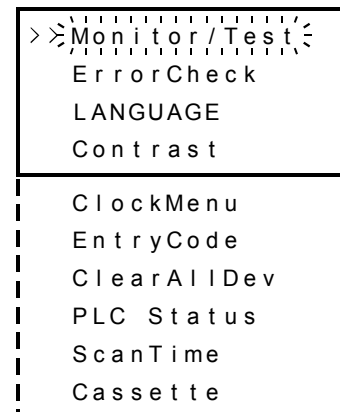

19.6 Menu Structure

Title screen

```
MELSEC - F
FX3U Series
Ver. 2.00
```

↓ Approx. 1.5 secs.

Top screen (Time display)

```
31. 5.05
23:59:59 [Tue]
```

Switched by system information setting

User message display function

```
<Production>
Target    10000
Production 100
Remaining  9900
```

User creation screen (example)

Operation keys

OK → Press the [OK] button

←ESC Press the [ESC] button

-^ / | +
- | / | + The [+] / [-] button are used to move the cursor and switch between display screens.

Menu screen

```
>>Monitor/Test
```

```
>>D (16 bit)
DD (32 bit)
T
C
R (16 bit)
DR (32 bit)
ER (16 bit)
DER (32 bit)
X
Y
M
S
User
```

```
>>ErrorCheck
```

Display example

```
ErrorCheck
No errors
```

```
>>LANGUAGE
```

```
LANGUAGE
>>日本語
English
```

```
>>Contrast
```

Display example

```
Contrast
0
(-5 ~ 10)
```

```
>>ClockMenu
```

```
>>Current time
Clock Setting
```

11	High-Speed Counters
12	Output Wiring
13	Wiring for Various Uses
14	Test Run, Maintenance, Troubleshooting
15	Input/Output Powered Extension Units
16	Input/Output Extension Blocks
17	Extension Power Supply Unit
18	Other Extension Units and Options
19	Display Module
20	Terminal Block

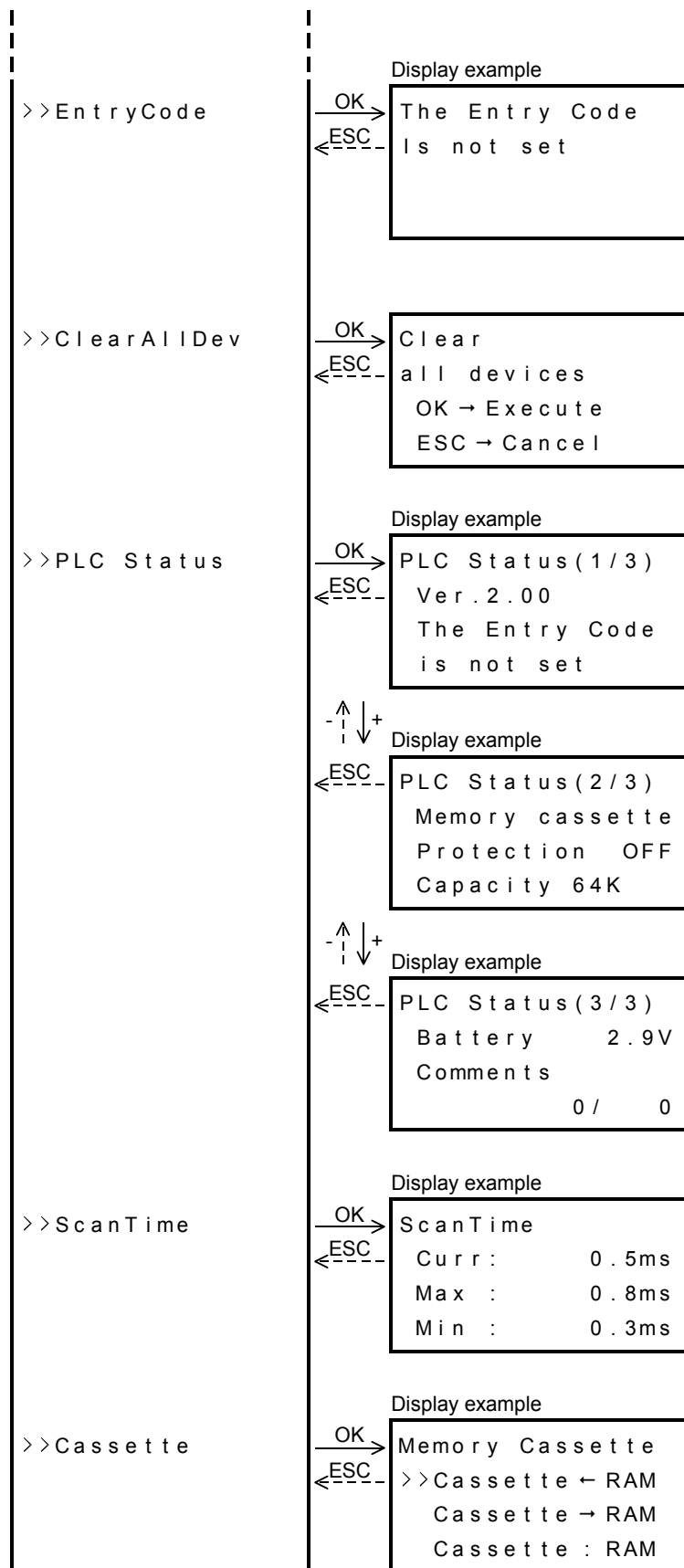

19.7 Monitor/Test Mode [Excluding User-Registered Devices]

19.7.1 Relevant devices

Monitoring and testing can be performed from the "Monitor/Test" menu for the devices listed below. (Monitoring/testing is not possible for the file register (D) and the index register (V/Z)).

- ✓: Possible △: Possible under certain conditions
□: Not possible -: Item not supported by this device

Device	Monitored Items					Test Items		
	Contact	Reset	Operation Direction	Current Value	Setting Value	Forced ON/OFF	Current Value Change	Setting Change
Input [X]	✓	-	-	-	-	-	-	-
Output [Y]	✓	-	-	-	-	△*1	-	-
Auxiliary relay [M]	✓	-	-	-	-	△*1	-	-
State [S]	✓	-	-	-	-	△*1	-	-
Timer [T]	✓	✓	-	✓	✓	✓	✓	△*2*3
Counter [C]	✓	✓	✓*4	✓	✓	✓	✓	△*2*3
Data register [D, DD]	-	-	-	✓	-	-	✓	-
File register [D, DD]	-	-	-	□	-	-	□	-
Extended register [R, DR]	-	-	-	✓	-	-	✓	-
Extended file register [ER, DER]*5	-	-	-	✓	-	-	✓	-
Index register (V,Z)	-	-	-	□	-	-	□	-

- *1. A forced ON or OFF is executed for only one operation cycle, and therefore has a considerable effect on the SET/RST and self retaining circuits when the PLC is running. Moreover, a forced ON/OFF result is retained for devices (Y,M,S) which are not being driven by an OUT instruction, etc., in the program.
- *2. Setting values of timer and counter can be changed when the PLC status is as shown below.

Program Memory Type		RUN/STOP Status	Setting Change Enabled/Disabled
Internal RAM		RUN	Enabled
		STOP	Enabled
Memory cassette	PROTECT switch ON	RUN	Disabled
		STOP	Disabled
	PROTECT switch OFF	RUN	Enabled
		STOP	Enabled

- *3. The following setting changes are possible.

Selectable Setting Values		Changeable Content	Setting Description
Direct setting	Without index modifier [Direct (K,H)]	Direct numeral setting	The directly specified value becomes the setting value.
	With index modifier [direct (K,H) + index register (V0 to V7, Z0 to Z7)]		The [directly specified numerical value] + [index register's current value] becomes the setting value.
Indirect setting	Without index modifier [data register D, extended register (R)]	Indirectly specified device No.	The specified device's current value becomes the setting value.
	With index modifier [data register (D) + index register (V0 to V7, Z0 to Z7)], [Extended register (R) + index register (V0 to V7, Z0 to Z7)]		The [directly specified device No.] + [index register's current value] becomes the device No. specified by the setting value. That device's current value becomes the setting value.

- *4. The C200 to C255 32-bit up/down counters and the high-speed counters have counting directions.
- *5. Enabled only when a memory cassette is installed.

19.7.2 Monitor mode operation

This section explains the procedure for monitoring the input [X], output [Y], auxiliary relay [M], state [S], timer [T], counter [C], data registers [D, DD], extended registers [R, DR], and the extended file registers [ER, DER]. The file register [D] and the index registers [V,Z] cannot be monitored.

→ Refer to Subsection 19.7.3 for a monitor screen display example.

→ Refer to Section 19.8 for user-registered device operation procedures.

→ Refer to Section 19.21 for the procedure used to display the timer, counter, and data register current values as hexadecimal values.

- 1) At the menu screen, use the [+] and [-] buttons to move the cursor to the "Monitor/Test" item, then press [OK] to display the "device selection screen" shown at right.

To cancel the operation and return to the "top screen (time display)", press [ESC] at the menu screen

- 2) Use the [+] and [-] buttons to move the cursor to the device which is to be monitored.

To cancel the operation and return to the "menu screen", press [ESC].

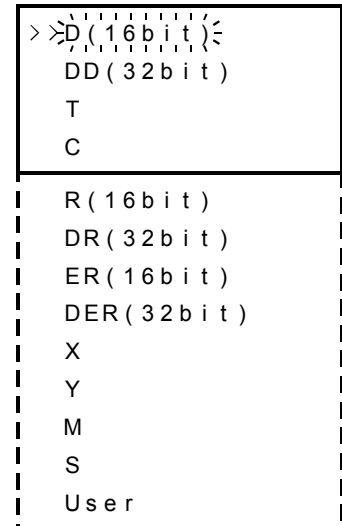

- 3) Press [OK] to display the monitor screen for the device which was selected for monitoring.

To cancel the operation and return to the "device selection screen", press [ESC].

After the power is turned on, the number of the device to be displayed is shown as follows.

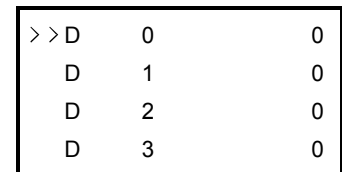

- a) The first time the power is turned on, the display begins with device No.1.

- b) At subsequent power ONs, the device which was being monitored at the previous operation is displayed (they are saved in memory for each device type).

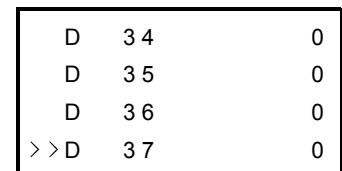

- 4) Use the [+] and [-] buttons to move the cursor or the screen to the until the device to be monitored is displayed.

→ Refer to Subsection 19.7.3 for status display.

Selected Device Type	Button	Operation Description
• All devices	ESC	Returns to the "device selection screen".
• Data registers (D, DD)	-	Scrolls upward. Press for 1 second or longer for high-speed scrolling. If pressed again at the beginning of the device No. list, the display jumps to the end of the device No. list.
• Extended registers (R, DR)		
• Extended file registers (ER, DER)	+	Scrolls downward. Hold for 1 second or longer for high-speed scrolling. If pressed again at the end of the device No. list, the display jumps to the beginning of the device No. list.
• Timer (T)		
• Counter (C)		
• Input (X)		
• Output (Y)	-	Scrolls the display screen upward. Hold for 1 second or longer for high-speed scrolling. If pressed again at the beginning of the device No. list, the display jumps to the end of the device No. list.
• Auxiliary relay (M)		
• State (S)	+	Scrolls the display screen downward. Hold for 1 second or longer for high-speed scrolling. If pressed again at the end of the device No. list, the display jumps to the beginning of the device No. list.
• All devices except (x)		
• All devices except (x)	OK	Switches to the test mode when hold for 1 second or longer.

19.7.3 Monitor screen & status display

→ Refer to Section 19.21 for the procedure used to display the current values as hexadecimal values.

1. Data register [D (16-bit)] / extended register [R (16-bit)] / extended file register [ER (16-bit)]

	Display Content
[1]	Device No.
[2]	Current value

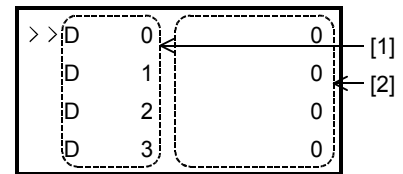

2. Data register [DD (32-bit)] / extended register [DR (32-bit)] / extended file register [DER (32-bit)]

	Display Content
[1]	Device No. [Upper 16-bit device No. (odd number)] [Lower 16-bit device No. (even number)]
[2]	Current value

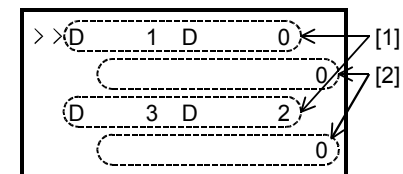

File register (D):

The file register (D) current value cannot be directly monitored at the display module.

3. Timer (T)

	Display Content
[1]	Device No.
[2]	Contact image ON: ■ OFF: Blank
[3]	Reset image ON: ■ OFF: Blank
[4]	Current value
[5]	Setting value or device specified by setting value (if an index modifier is present, the index register's device is also displayed).
[6]	Current value of device specified by setting value.

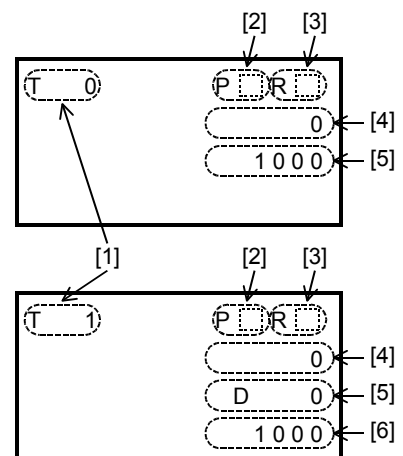

11	High-Speed Counters
12	Output Wiring
13	Wiring for Various Uses
14	Test Run, Maintenance, Troubleshooting
15	Input/Output Powered Extension Units
16	Input/Output Extension Blocks
17	Extension Power Supply Unit
18	Other Extension Units and Options
19	Display Module
20	Terminal Block

4. Counter [C]

	Display Content
[1]	Device No.
[2]	Contact image ON: ■ OFF: Blank
[3]	Reset image ON: ■ OFF: Blank
[4]	Count direction display UP count: ■ DOWN count: Blank (32-bit up/down counter and high-speed counter only)
[5]	Current value
[6]	Setting value or device specified by setting value (if an index modifier is present, the index register's device is also displayed).
[7]	Current value of device specified by setting value.

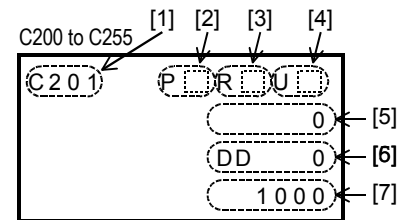
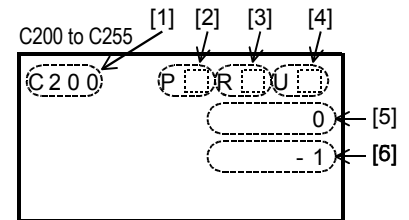
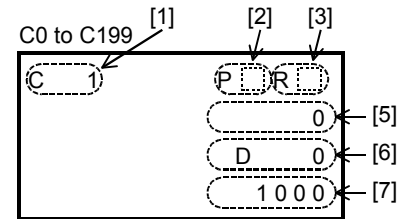
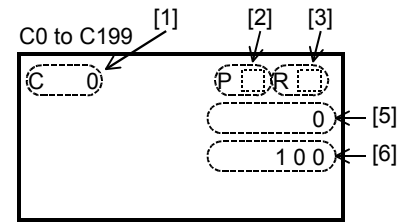

5. Input [X] / Output [Y] / Auxiliary Relay [M] / State [S]

	Display Content
[1]	Device No. at beginning of line. Input (X) and output (Y): 8 points per line. Auxiliary relay (M), special auxiliary relay (M), and state (S): 10 points per line.
[2]	ON/OFF status ON: Last digit of device No.. OFF: "•".

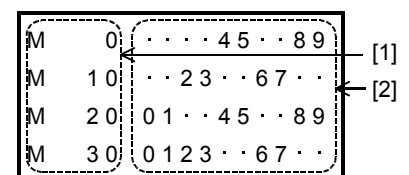
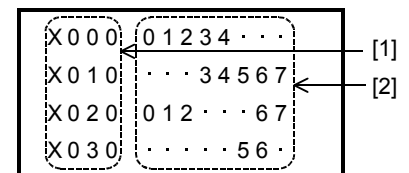

19.7.4 Test mode operation

There are 3 types of test mode operations, depending on the device type. The 3 operations are explained below.

→ Refer to Subsection 19.7.1 for test mode subject devices.

1. Data registers [D: D (16-bit), DD (32-bit)] / extended registers [R: R (16-bit), DR (32-bit)] / extended file registers [ER: ER (16-bit), DER (32-bit)] / user-registered devices

- 1) Perform a monitor mode operation to display the device whose current value is to be changed.

→ Refer to Subsection 19.7.2 for monitor function operation.

D 6 2 0 0	0
>> D 6 2 0 1	0
D 6 2 0 2	0
D 6 2 0 3	0

- 2) Hold the [OK] button for 1 second or longer to switch to the test mode. The current value begins blinking (refer to fig. at right).

D 6 2 0 0	0
D 6 2 0 1	>> 0
D 6 2 0 2	0
D 6 2 0 3	0

- 3) Use the [+] / [-] buttons to change the value as desired.
To cancel the operation and return to the "monitor screen", press [ESC].

Button	Operation Description
ESC	Cancels the operation and returns to the "monitor screen".
-	Reduces the value. Hold for 1 second or longer for high-speed reduction.
+	Increases the value. Hold for 1 second or longer for high-speed increase.
OK	Registers the current value and returns to the "monitor screen".

D 6 2 0 0	0
D 6 2 0 1	>> 5
D 6 2 0 2	0
D 6 2 0 3	0

- 4) Press [OK] to register the current value and return to the "monitor screen".

- File register (D)

The display module's test function cannot be used to change the current value of the file register (D) which is stored in the program memory.

11	High-Speed Counters
12	Output Wiring
13	Wiring for Various Uses
14	Test Run, Maintenance, Troubleshooting
15	Input/Output Powered Extension Units
16	Input/Output Extension Blocks
17	Extension Power Supply Unit
18	Other Extension Units and Options
19	Display Module
20	Terminal Block

2. Timer [T], counter [C]

- 1) Perform a monitor mode operation to display the device where the test function is to be used.
→ Refer to Subsection 19.7.2 for monitor function operation.

[Monitor screen]

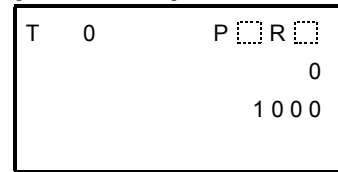

- 2) Press the [OK] button to display the cursor, then select the "test subject selection screen".
To cancel the operation and return to the "monitor screen", press [ESC].

[Test subject selection screen]

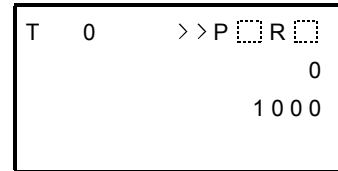

- 3) Use the [+] / [-] buttons to select the test subject.
To cancel the operation and return to the "monitor screen", press [ESC].

Test Subject	Test Description
[1]	Contact forced ON/OFF
[2]	Current value change
[3]	Setting value change

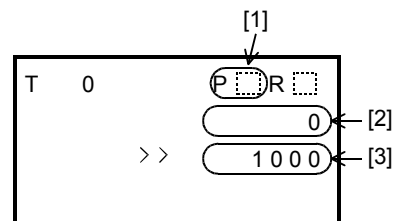

- 4) Hold the [OK] button for 1 second or longer to register the test subject selection, and switch to the test mode.
To cancel the operation and return to the "test subject selection screen", press [ESC].

Test Subject	Status when [OK] is hold for 1 second or longer
[1]	No change
[2]	Numeric value begins blinking.
[3]	

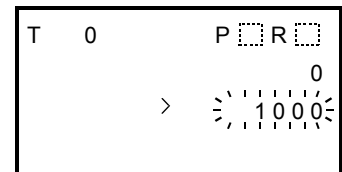

- 5) Operation varies as shown below, depending on the selected test subject.

- a) For "contact forced ON/OFF"

The contact ON/OFF status is highlighted when [OK] is pressed.

Button	Operation Description
ESC	Cancels the operation and returns to the "test subject selection screen".
-	Disabled
+	Disabled
OK	Highlights the contact ON/OFF status, meaning the current value can not be changed.

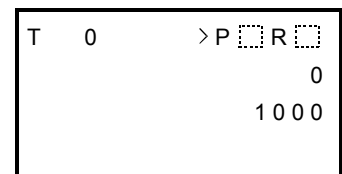

- b) For "current value change"

Use the [+] / [-] buttons to change the value as desired, then press [OK] to register the changed value.

Button	Operation Description
ESC	Cancels the operation and returns to the "test subject selection screen".
-	Reduces the value. Hold for 1 second or longer for high-speed reduction.
+	Increases the value. Hold for 1 second or longer for high-speed increase.
OK	Registers the current value or the setting value and returns to the "test subject selection screen".

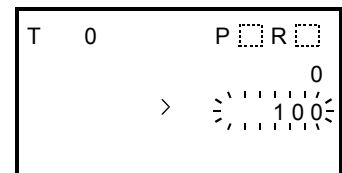

- c) For indirect setting format

- ① Use the [+] / [-] buttons to select the desired setting method (refer to table below), then press [OK] to register this selection.

Selectable Setting Values	Changeable Content	Setting Description
Direct setting (without index modifier) [Direct (K,H)]	Direct numeral setting	The directly specified value becomes the setting value.
Direct setting (with index modifier) [direct (K,H) + index register (V0 to V7, Z0 to Z7)]		The [directly specified numerical value] + [index register's current value] becomes the setting value.
Indirect setting (without index modifier) [data register (D), extended register (R)]	Indirectly specified device No.	The specified device's current value becomes the setting value.
Indirect setting (with index modifier) [data register (D) + index register (V0 to V7, Z0 to Z7)], [Extended register (R) + index register (V0 to V7, Z0 to Z7)]		The [directly specified device No.] + [index register's current value] becomes the device No. specified by the setting value. That device's current value becomes the setting value.

- ② Use the [+] / [-] buttons to determine the setting value.
The content that is changed varies according to the selected setting method, as shown below.
- For "direct setting" or "direct setting + index register" method:
Use the [+] / [-] buttons to change the value as desired, then press [OK] to register the changed value.
 - For "indirect setting" or "indirect setting + index register" method:
Use the [+] / [-] buttons to change the device No. as desired, then press [OK] to register the setting value.

- 6) After the setting operation is completed, return to the "test subject selection screen", where the [ESC] button can then be pressed to return to the "monitor screen".

11	High-Speed Counters
12	Output Wiring
13	Wiring for Various Uses
14	Test Run, Maintenance, Troubleshooting
15	Input/Output Powered Extension Units
16	Input/Output Extension Blocks
17	Extension Power Supply Unit
18	Other Extension Units and Options
19	Display Module
20	Terminal Block

3. Output [Y] / auxiliary relay [M] / special auxiliary relay [M] / state [S]

Forced ON/OFF operations are possible for the output [Y] / auxiliary relay [M] / special auxiliary relay [M] / state [S] contacts.

- 1) Perform a monitor mode operation to display the device whose ON/OFF status is to be changed.
 → Refer to Subsection 19.7.2 for monitor function operation.

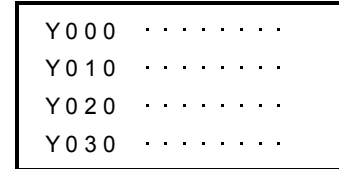

- 2) Hold the [OK] button for 1 second or longer to switch to the test mode. The device then begins blinking (refer to figure at right). To cancel the operation and return to the "test subject selection screen", press [ESC].

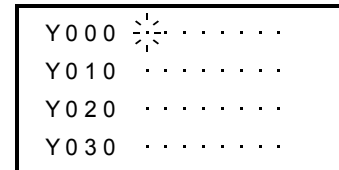

- 3) Use the [+] / [-] buttons to move the blinking position to the device where a forced ON/OFF is desired. To cancel the operation and return to the "monitor screen", press [ESC].

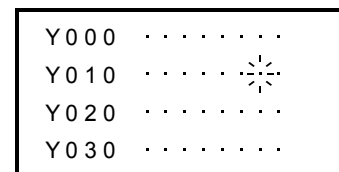

Button	Operation Description
ESC	Cancels the operation and returns to the "monitor screen".
-	Moves in the lower device No. direction (for forced ON/OFF subject selection). Hold for 1 second or longer for high-speed scrolling.
+	Moves in the higher device No. direction (for forced ON/OFF subject selection). Hold for 1 second or longer for high-speed scrolling.
OK	Highlights the contact's ON/OFF status.

- 4) Press the [OK] button to highlight the contact's ON/OFF status. To cancel the operation and return to the "monitor screen", press [ESC].

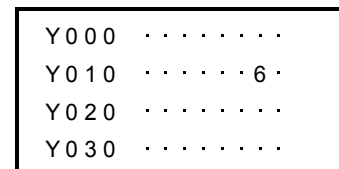

Button	Operation Description
ESC	Cancels the operation and returns to the "monitor screen".
-	Moves in the lower device No. direction (for forced ON/OFF subject selection). Hold for 1 second or longer for high-speed scrolling.
+	Moves in the higher device No. direction (for forced ON/OFF subject selection). Hold for 1 second or longer for high-speed scrolling.
OK	Highlights the contact ON/OFF status.

- 5) Press [ESC] to return to the monitor screen.

19.7.5 Test mode operation notes

When using multiple same-number timers (T) and counters (C).

Operation occurs as follows if multiple timers [T] and counters [C] are used in programs which contain CJ instructions and step ladders.

- When a setting change is performed after switching from the device monitor to the test function mode, the setting change is applied to the timer [T] or counter [C] which is nearest to Step 0.
- When changing the setting values for same-number timers [T] and counters [C], use the programming tool to change the program.

19.8 Monitor/Test Mode [User-Registered Devices]

Regarding user-registered devices at "Monitor/Test" menu, monitor and test operations can be performed for a maximum of 4 data registers (16-bit/32-bit) specified by the system information.

→ Refer to Section 19.19 for the user-registered device setting procedure.

19.8.1 Monitor mode operation

- At the menu screen, use the [+] and [-] buttons to move the cursor to the "Monitor/Test" item, then press [OK] to display the "device selection screen" shown to the right.
To cancel the operation and return to the "top screen (time display)", press [ESC] at the menu screen
- "Use the [+] and [-] buttons to move the cursor to the "User" item.
To cancel the operation and return to the "device selection screen", press [ESC].

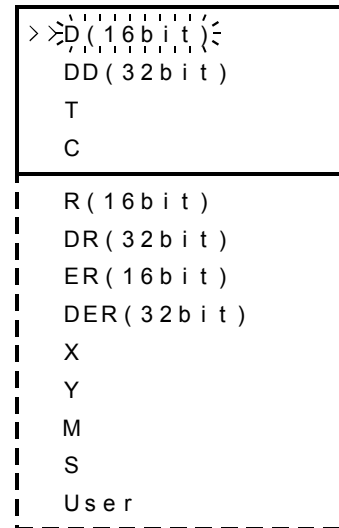

- Press [OK] to display the data registers specified by the system information.
The first time the power is turned on, the display begins with device No.1 of the "user-registered devices". At subsequent power ONs, the device which was being monitored at the previous operation is displayed.
If a specified user-registered device has been changed, the newly specified device is displayed.
To cancel the operation and return to the "device selection screen", press [ESC].

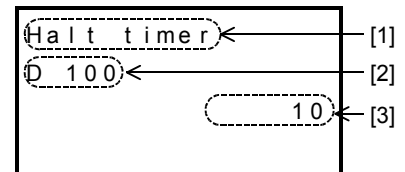

	Display Content
[1]	Device comments (registered at the PLC) are displayed together with the devices. If no device comment has been registered, the device comment area is left blank.
[2]	Device included in the user-registered devices
[3]	Current value

- Use the [+] and [-] buttons to scroll the user-registered devices screen.
To cancel the operation and return to the "device selection screen", press [ESC].

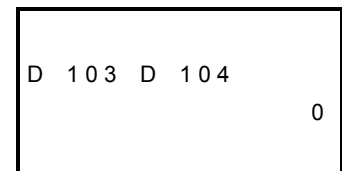

Button	Operation Description
ESC	Returns to the "device selection screen".
-	Scrolls the user-registered devices. (User-specified device 1 → user-specified device 4 → user-specified device 3 → user-specified device 2 → user-specified device 1)
+	Scrolls the user-registered devices. (User-specified device 1 → user-specified device 2 → user-specified device 3 → user-specified device 4 → user-specified device 1)
OK	Switches to the test mode when hold for 1 second or longer.

11	High-Speed Counters
12	Output Wiring
13	Wiring for Various Uses
14	Test Run, Maintenance, Troubleshooting
15	Input/Output Powered Extension Units
16	Input/Output Extension Blocks
17	Extension Power Supply Unit
18	Other Extension Units and Options
19	Display Module
20	Terminal Block

19.8.2 Test mode operation

- 1) Perform a monitor mode operation to display the user-registered device whose current value is to be changed.
→ Refer to Subsection 19.7.2 for monitor function operation.

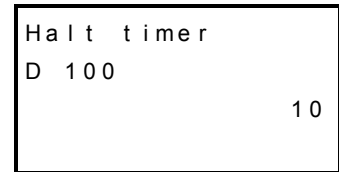

- 2) Hold the [OK] button for 1 second or longer to switch to the test mode. The current value then begins blinking (refer to fig. at right).
- 3) Use the [+] / [-] buttons to change the value as desired. To cancel the operation and return to the "monitor screen", press [ESC].

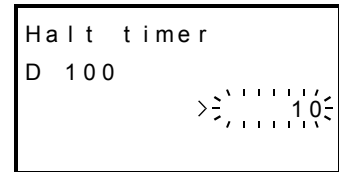

Button	Operation Description
ESC	Cancels the operation and returns to the "monitor screen".
-	Reduces the value. Hold for 1 second or longer for high-speed reduction.
+	Increases the value. Hold for 1 second or longer for high-speed increase.
OK	Registers the current value and returns to the "monitor screen".

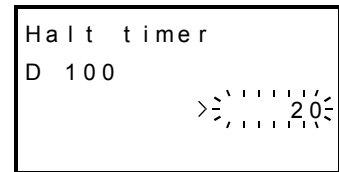

- 4) Press [OK] to register the current value and return to the "user registered devices screen".

19.9 Error Check

The main unit's error status displays at the "ErrorCheck" menu.

- 1) At the menu screen, use the [+] / [-] buttons to move the cursor to the "ErrorCheck" item, then press [OK].
The error check result then displays at the "error display screen" (refer to fig. at right).
To cancel the operation and return to the "top screen (time display)", press [ESC] at the menu screen
- 2) If multiple errors have occurred, the [+] / [-] keys can be used to switch between the error display pages.

When no errors have occurred

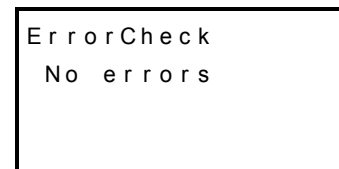

When 1 error has occurred

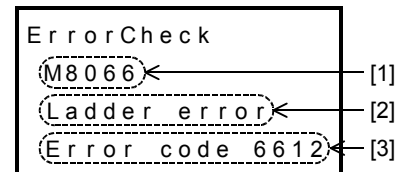

When multiple errors have occurred

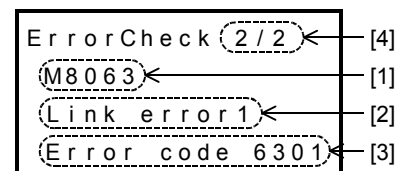
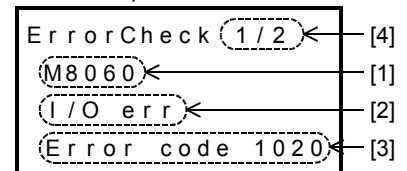

Button	Operation Description
ESC	Returns to the "menu screen".
-	1 error or less: Disabled 2 errors or more: Displays the previous-page's error screen.
+	1 error or less: Disabled 2 errors or more: Displays the next-page's error screen.
OK	Returns to the "menu screen".

Display Content

	Display Content
[1]	Active error flag
[2]	Error name
[3]	Error code
[4]	Number of concurrent errors (displays only when multiple errors have occurred)

- 3) To cancel the operation and return to the "menu screen", press [ESC].

19.10 LANGUAGE (Menu Display Language Setting)

The language used at the display module menus is specified at the "LANGUAGE" menu. The language setting procedure is described below.

All operation explanations and display screen examples in this manual are in Japanese. When the menu display language is set to English, please convert the screen messages to their English translations.

→ Refer to Section 19.25 for the Japanese & English display character correspondence table.

19.10.1 Changing to Japanese menus

The procedure for changing from English menus to Japanese menus is described below.

- 1) Turn the PLC power on.
Following a brief title screen display (1.5 seconds), the "current time screen" or a "user message" is displayed.

Title screen

```
MELSEC - F
FX3U Series
Ver. 2.00
```

↓ Approx.
1.5 secs.

Top screen (Time display)

```
05 . 5 . 31
23 : 59 : 59 [ Tue ]
```

or

User creation screen (example)

```
<Production>
Target      10000
Production   100
Remaining    9900
```

- 2) Press the [OK] button to display the menu screen shown to the right (4 lines of the menu display).

```
>>Monitor/Test<
ErrorCheck
LANGUAGE
Contrast

ClockMenu
EntryCode
ClearAllDev
PLC Status
ScanTime
Cassette
```

- 3) At the menu screen, use the [+] / [-] buttons to move the cursor to the "LANGUAGE" item, then press [OK] to display the "display language selection screen".
To cancel the operation and return to the "top screen (time display)", press [ESC].

```
LANGUAGE
日本語
>>English<
```

11

High-Speed
Counters

12

Output Wiring

13

Wiring for
Various Uses

14

Test Run,
Maintenance,
Troubleshooting

15

Input/Output
Powered
Extension Units

16

Input/Output
Extension
Blocks

17

Extension
Power Supply
Unit

18

Other Extension
Units and
Options

19

Display Module

20

Terminal Block

- 4) Use the [+] / [-] buttons to move the cursor to "日本語".
To cancel the operation and return to the "menu screen", press [ESC].

Button	Operation Description
ESC	Cancels the operation and returns to the "menu screen".
-	Moves the cursor upward.
+	Moves the cursor downward.
OK	Registers the selected display language and returns to the "menu screen".

- 5) Press [OK] to register the selected display language and return to the "menu screen".

19.10.2 Changing to English menus

Refer to Subsection 19.10.1 "Changing to Japanese menus" for the access procedure from the title screen.

- 1) At the menu screen, use the [+] / [-] buttons to move the cursor to the "LANGUAGE" item, then press [OK] to display the "display language selection screen".
To cancel the operation and return to the "top screen (time display)", press [ESC].

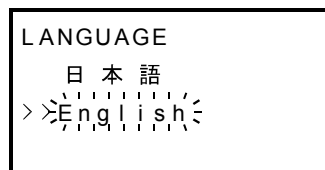

- 2) Use the [+] / [-] buttons to move the cursor to "English".
To cancel the operation and return to the "menu screen", press [ESC].

Button	Operation Description
ESC	Cancels the operation and returns to the "menu screen".
-	Moves the cursor upward.
+	Moves the cursor downward.
OK	Registers the selected display language and returns to the "menu screen".

- 3) Press [OK] to register the selected display language and return to the "menu screen".

19.10.3 D8302 changes by program & related devices

Selections made at this menu are saved at D8302.
D8302 has a battery backup for latch.
D8302 changes by user program can also be specified.

D8302 Current Value	Display Language
K0	Japanese
K1	English
Other	English

When the display language is set to "Japanese"

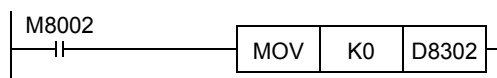

19.11 Contrast

The liquid crystal display contrast setting is specified at the "Contrast" menu. Selections made at this menu are saved at D8302. A contrast setting of "0" is specified at factory default.

- At the menu screen, use the [+] / [-] buttons to move the cursor to the "Contrast" item, then press [OK] to display the "contrast adjustment screen".
To cancel the operation and return to the "top screen (time display)", press [ESC].

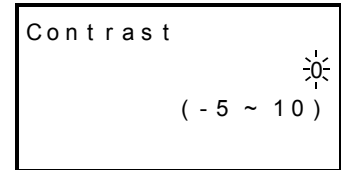

- Use the [+] / [-] buttons to adjust the contrast.
To cancel the operation and return to the "menu screen", press [ESC].

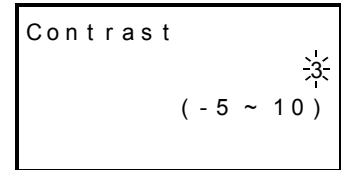

Button	Operation Description
ESC	Cancels the operation and returns to the "menu screen".
-	Lowers the contrast (decreases the numeric value. The value can be decreased to -5.)
+	Increases the contrast (increases the numeric value. The value can be increased to +10.)
OK	Registers the selected setting and returns to the "menu screen".

- Press the [OK] button to register the selected setting and return to the "menu screen".

11	High-Speed Counters
12	Output Wiring
13	Wiring for Various Uses
14	Test Run, Maintenance, Troubleshooting
15	Input/Output Powered Extension Units
16	Input/Output Extension Blocks
17	Extension Power Supply Unit
18	Other Extension Units and Options
19	Display Module
20	Terminal Block

19.12 Clock Menu (Current Time Setting)

The "ClockMenu" menu consists of "current time display" and the "time setting" items.
The current time should be set before operating the system.

19.12.1 Current time setting procedure

- 1) At the menu screen, use the [+] / [-] buttons to move the cursor to the "ClockMenu" item, then press [OK] to display the selection screen shown at right.
To cancel the operation and return to the "top screen (time display)", press [ESC].

```
> > Current time
    Clock setting
```

- 2) Use the [+] / [-] buttons to move the cursor to the "Clock setting" item.
To cancel the operation and return to the "menu screen", press [ESC].

```
Current time
> > Clock setting
```

- 3) Press the [OK] button to display the "Clock setting screen".
To cancel the operation and return to the "selection screen", press [ESC].

```
Clock setting
      19 . 8 . 1993 *
      7 : 11 : 19 [ Thu ]
```

- 4) Use the [+] / [-] buttons to change the blinking data as desired, then press [OK] to register the change.
Settings are performed in the following sequence: Year → Month → Day → Hours → Minutes → Seconds.
After pressing [OK] to register the final "seconds" setting, a "Current time is set" message is displayed, completing the current time setting procedure.

```
Clock setting
      31 . 1 . 2004 *
      23 : 59 : 59 [ Sat ]
```

* The default "Year" display is a 2-digit value indicating the Western calendar year.

Button	Operation Description
ESC	Returns to the previous setting item. Returns to the "selection screen", when at the "Year" item ("Year" is blinking) position.
-	Reduces the value. Hold for 1 second or longer for high-speed reduction.
+	Increases the value. Hold for 1 second or longer for high-speed increase.
OK	Proceeds to the next setting item. "Current time is set" message displays if pressed at the "Seconds" item ("Seconds" is blinking).

- 5) Press [OK] or [ESC] to return to the "selection screen".
- 6) Press [ESC] to return to the "menu screen".

```
Current time
> > Clock setting
```

19.12.2 Displaying the current time

- 1) At the menu screen, use the [+] / [-] buttons to move the cursor to the "ClockMenu" item, then press [OK] to display the selection screen shown to the right.
To cancel the operation and return to the "top screen (time display)", press [ESC].
- 2) Use the [+] / [-] buttons to move the cursor to the "Current time" item. To cancel the operation and return to the "menu screen", press [ESC].
- 3) Press the [OK] button to display the current time.
To cancel the operation and return to the "selection screen", press [ESC].

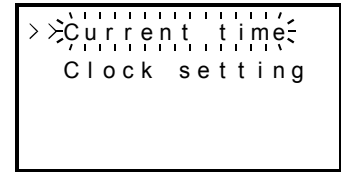

Button	Operation Description
ESC	Returns to the "selection screen".
-	Disabled
+	Disabled
OK	Returns to the "selection screen".

- 4) Press [OK] or [ESC] to return to the "selection screen".
- 5) Press [ESC] to return to the "menu screen".

2-digit display

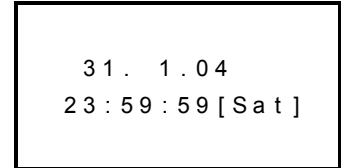

4-digit display

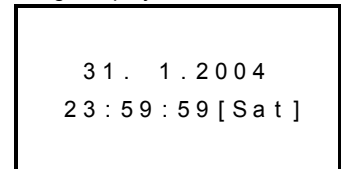

19.12.3 Changing the current time's "Year" from 2-digit format to 4-digit format

The "Year" data displays as 2-digit value with a default. This can be changed to a 4-digit display by the following programming.

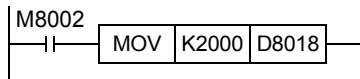

It is also possible to set the current time with a sequence program.

→ Refer to the "time setting" (special devices D8013 to D8019) section of the Programming Manual.

11	High-Speed Counters
12	Output Wiring
13	Wiring for Various Uses
14	Test Run, Maintenance, Troubleshooting
15	Input/Output Powered Extension Units
16	Input/Output Extension Blocks
17	Extension Power Supply Unit
18	Other Extension Units and Options
19	Display Module
20	Terminal Block

19.13 Keyword (Entry code)

Entry codes registered at the PLC can be canceled from the "EntryCode" menu.
When canceled, all operations are enabled.
Registering or changing entry codes is not possible at the display module.
The programming tool must be used in advance to register new entry codes.

19.13.1 Keyword (Entry code) types & levels

Entry codes can be entered in 2 ways (8-digit or 16-digit*¹), depending on the peripheral device in question.

- For a [entry code (8-digit)] + [2nd entry code (8-digit)] = 16-digit input:
Processing is possible only with a peripheral device version compatible with the FX3U PLC.
- For an entry code (8-digit) input only:
Processing is possible even with a peripheral device version that is not compatible with the FX3U PLC.

Number Of Digits	Registration Method	Peripheral Device* ²		Entry Code Registration Level	Entry Code Description
		FX3U Compatible	Not FX3U Compatible		
16-digit* ¹	By selecting the entry code registration level at the GX Developer's setting screen.	✓	-	Reading/writing prohibited	16-digit hexadecimal value (A to F, 0 to 9) [Ex] FAB05C25DAECF293 AABCDEF34509345
				Writing prohibited	
				All online operations prohibited	
8-digit	By entering the level at the first character when entering the entry code.	✓	✓	A (A, 0 to 9 first char.)	8-digit hexadecimal value beginning with "A" or "0 to 9". [Ex]0ABCDEF2, AABCD345
				B	8-digit hexadecimal value beginning with "B". [Ex]B1234567, BABCDEF7
				C	8-digit hexadecimal value beginning with "C". [Ex]C8904567, CDEF567F

- *1. Customer keyword / permanent PLC lock included. However, permanent PLC lock does not have a keyword input.
FX3U PLC Ver. 2.61 or later supports the customer keyword and permanent PLC lock.
- *2. GX Developer Ver. 8.89T or later supports the customer keyword and permanent PLC lock.

19.13.2 Level-specific restrictions screen list

- ✓: Function enabled
- △: Timer and counter setting values cannot be changed.
- : Function disabled

Function name	None	Entry Code: 8 digits Label entered as the first character at Entry Code input			Entry Code*1 : 16 digits Selected at GX Developer setting screen*2		
		A	B	C	All online operations prohibited	Writing prohibited	Reading/ writing prohibited
Top screen (time display)	✓	✓		✓	✓		✓
Monitor/ Test	Device	✓	–	△	–		△
	User (User-registered device)	✓	–	✓	–		✓
ScanTime (Scan time display)	✓	–		✓	–		✓
PLC status	✓	–		✓	–		✓
ErrorCheck	✓	–		✓	–		✓
User message display	✓	✓		✓	✓		✓
Display screen protect function	✓	–		–	–		–
Menu display language setting	✓	–		✓	–		✓
Contrast adjustment	✓	–		✓	–		✓
Time	Display	✓	✓	✓	✓		✓
	Setting	✓	–	✓	–		✓
Entry Code (cancel)	–	✓		✓	✓		✓
Clear all device (Device all-clear)	✓	–		✓	–		✓
Memory cassette transfer	✓	–		–	–		–

*1. Customer keyword / permanent PLC lock included. However, permanent PLC lock does not have a keyword input.

FX3U PLC Ver. 2.61 or later supports the customer keyword and permanent PLC lock.

*2. GX Developer Ver. 8.89T or later supports the customer keyword and permanent PLC lock.

11	High-Speed Counters
12	Output Wiring
13	Wiring for Various Uses
14	Test Run, Maintenance, Troubleshooting
15	Input/Output Powered Extension Units
16	Input/Output Blocks
17	Extension Power Supply Unit
18	Other Extension Units and Options
19	Display Module
20	Terminal Block

19.13.3 Keyword (Entry code) storage

The system has no process for recovering registered entry codes which are forgotten. Therefore, be sure to store the entry codes in a secure location.

19.13.4 Screens requiring keywords (entry codes) for access

At the menu screen, use the [+] / [-] buttons to move the cursor to the "EntryCode" item, then press [OK] to display one of the 4 screens shown below (the screen that displays depends on the entry code status).
 If no entry codes are registered, press [ESC] to return to the "menu screen".
 To cancel the operation and return to the "top screen (time display)", press [ESC].

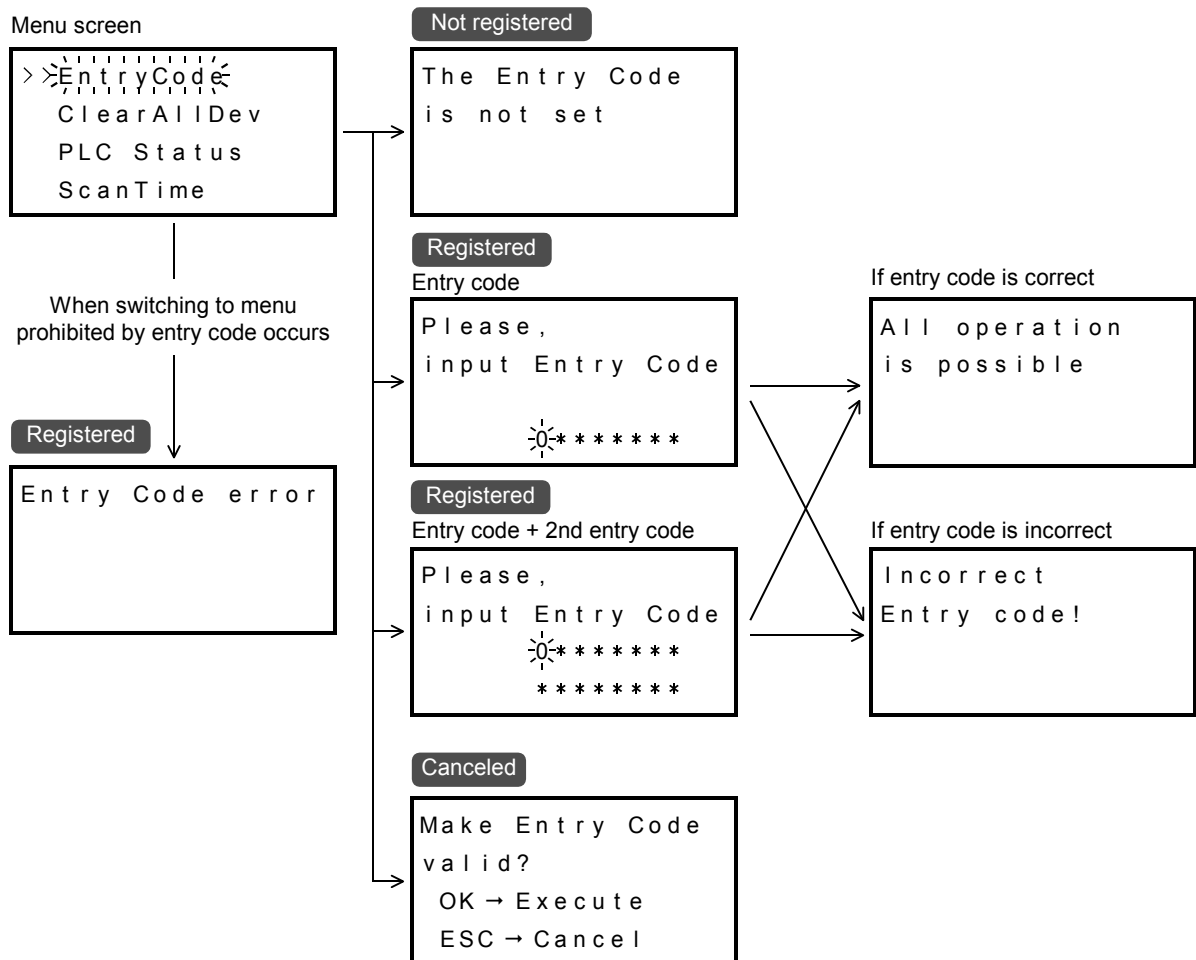

19.13.5 Canceling an keyword (entry code)

- At the menu screen, use the [+] / [-] buttons to move the cursor to the "EntryCode" item, then press [OK] to display the "entry code input screen".
If an entry code has been registered, one of the following screens is displayed.
 - If a 16-digit entry code is registered, an 8-digit × 2-line screen (shown at left below) is displayed.
 - If an 8-digit entry code is registered, an 8-digit × 1-line screen (shown at right below) is displayed.

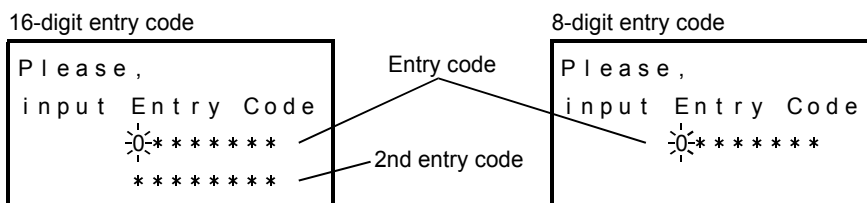

- Use the [+] / [-] buttons to specify the first digit of the entry code, then press [OK] to proceed to the next digit. To cancel the operation and return to the "menu screen", press [ESC].

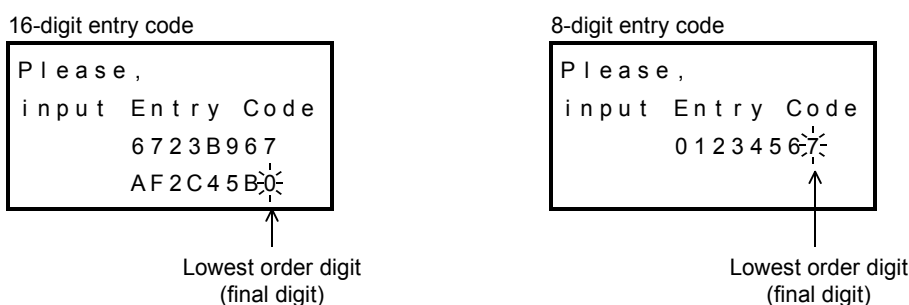

Button		Operation Description	
ESC		Cancels the operation and returns to the "menu screen" if pressed when the entry code's left-most digit (highest order digit) is blinking. Cancels the input and moves leftward to the next digit (higher order digit) if pressed when a digit other than the left-most digit is blinking.	
-		Reduces the value (F→E...2→1→0). Hold for 1 second or longer for high-speed reduction.	
+		Increases the value (0→1→2...E→F). Hold for 1 second or longer for high-speed increase.	
OK	Highest order digit to 2nd digit	Registers the specified value and moves to the next digit input position. If [OK] is pressed at the lowest order digit, and if the entered entry code is correct, the Entry Code is canceled.	
	Lowest order digit (final digit)	Correct Entry Code	An "All operation is possible" message appears, and the Entry Code is canceled.
		Incorrect Entry Code	A "Incorrect Entry Code" message appears.

- If the [OK] button is pressed at the lowest order position, the entered Entry Code is registered and the message shown to the right appears.
If the "Incorrect Entry Code" message appears, press [ESC] and return to step 1).
- Press [OK] or [ESC] to return to the "menu screen".

If entry code is correct

All operation
is possible

If entry code is incorrect

Incorrect
Entry code!

19.13.6 Enabling an entry code

- 1) At the menu screen, use the [+] / [-] buttons to move the cursor to the "EntryCode" item, then press [OK] to display the "enable entry code" screen.
- 2) Press the [OK] button to enable the entry code. Or, to retain the entry code's canceled status, press [ESC].

Make Entry Code
valid?
OK → Execute
ESC → Cancel

Button	Operation Description
ESC	Cancels the operation and returns to the "menu screen".
-	Disabled
+	Disabled
OK	Enables the Entry Code and returns to the "menu screen".

19.14 Device All-Clear

The devices listed below can be initialized (contact OFF, or current value to "0") from the "Clear all devices" menu when a PLC STOP status is in effect.

Subject devices	Output [Y], auxiliary relay (special relay) [M], state [S], timer [T], counter [C], data register (special data register) [D], extended register [R]. File register [D] is not a subject device.
Non-subject devices	Input [X], file register [D], extended file register [ER].

19.14.1 Device all-clear operation

- 1) At the menu screen, use the [+] / [-] buttons to move the cursor to the "ClearAllDev" item, then press [OK] to display the "Clear all devices" screen.
To cancel the operation and return to the "top screen (time display)", press [ESC].

Clear
all devices
OK → Execute
ESC → Cancel

- 2) Press the [OK] button to initialize the subject devices. Or, to cancel the operation, press [ESC].
If the PLC is running at this time, a "PLC is running" message is displayed and the all-clear is not executed. In this case, press [OK] or [ESC] to return to the "menu screen".

All device
were cleared

Button	Operation Description
ESC	Cancels the operation and returns to the "menu screen".
-	Disabled
+	Disabled
OK	Initializes the subject devices and returns to the "menu screen".

When PLC is running

PLC is running

- 3) Press [OK] or [ESC] to display the "menu screen".

19.15 PLC Status

The PLC statuses shown below can be displayed from the "PLC Status" menu.

→ Refer to Subsection 19.15.2 for display details.

Page Title	Display Item
PLC Status(1/3)	<ul style="list-style-type: none"> Version Entry code status
PLC Status(2/3)	<ul style="list-style-type: none"> Program memory type Memory cassette's write protect status Program memory capacity
PLC Status(3/3)	<ul style="list-style-type: none"> Battery voltage Number of registered comments

19.15.1 Display operation

- At the menu screen, use the [+] / [-] buttons to move the cursor to the "PLC Status" item, then press [OK] to display the "PLC Status (1/3)" screen.
To cancel the operation and return to the "top screen (time display)", press [ESC].

```

PLC Status ( 1 / 3 )
Ver . 2 . 0 0
All operation
is unrestricted
    
```

- Use the [+] / [-] buttons to switch between the PLC Status screen pages.
Press [OK] or [ESC] to return to the "menu screen".

```

PLC Status ( 1 / 3 )
Ver . 2 . 0 0
PLC operation
is limited
    
```

Button	Operation Description
ESC	Returns to the "menu screen".
-	Returns to the previous page. <div style="border: 1px solid black; padding: 2px; width: fit-content; margin: 5px auto;"> → PLC Status(3/3) → PLC Status(2/3) → PLC Status(1/3) ← </div>
+	Proceeds to the next page. <div style="border: 1px solid black; padding: 2px; width: fit-content; margin: 5px auto;"> → PLC Status(1/3) → PLC Status(2/3) → PLC Status(3/3) ← </div>
OK	Returns to the "menu screen".

```

PLC Status ( 2 / 3 )
Internal Memory
Protection - -
Capacity 64K
    
```

- Press [OK] or [ESC] to return to the "menu screen".

```

PLC Status ( 3 / 3 )
Battery      3 . 2 V
Comments
              1 0 0 0 / 2 0 0 0
    
```

11	High-Speed Counters
12	Output Wiring
13	Wiring for Various Uses
14	Test Run, Maintenance, Troubleshooting
15	Input/Output Powered Extension Units
16	Input/Output Extension Blocks
17	Extension Power Supply Unit
18	Other Extension Units and Options
19	Display Module
20	Terminal Block

19.15.2 PLC status display items

1. PLC Status 1/3

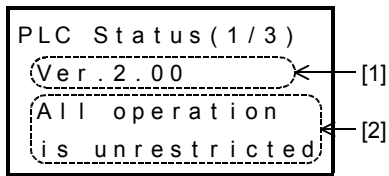

Display Content											
[1]	Main unit's version information.										
[2]	Indicates the PLC's entry code registration status. Messages vary according to the entry code status. When a 16-bit entry code status is "all online operations prohibited", and when an 8-bit entry code status is "level A", the entry code must be canceled in order to view the PLC information.										
	<table border="1"> <thead> <tr> <th>Displayed message</th> <th>PLC status</th> </tr> </thead> <tbody> <tr> <td>PLC operation is limited</td> <td> <ul style="list-style-type: none"> For 16-bit entry code: A "writing prohibit" or "reading/writing prohibit" entry code is registered. For 8-bit entry code: A "Level B" or "Level C" entry code is registered. </td> </tr> <tr> <td>All operation is unrestricted</td> <td>The registered entry code has been canceled by an "entry code" menu operation.</td> </tr> <tr> <td>The Entry Code is not set</td> <td>No entry codes have been registered.</td> </tr> <tr> <td>Fatal error occurred</td> <td>→ Refer to Subsection 19.24.1 for details.</td> </tr> </tbody> </table>	Displayed message	PLC status	PLC operation is limited	<ul style="list-style-type: none"> For 16-bit entry code: A "writing prohibit" or "reading/writing prohibit" entry code is registered. For 8-bit entry code: A "Level B" or "Level C" entry code is registered. 	All operation is unrestricted	The registered entry code has been canceled by an "entry code" menu operation.	The Entry Code is not set	No entry codes have been registered.	Fatal error occurred	→ Refer to Subsection 19.24.1 for details.
	Displayed message	PLC status									
	PLC operation is limited	<ul style="list-style-type: none"> For 16-bit entry code: A "writing prohibit" or "reading/writing prohibit" entry code is registered. For 8-bit entry code: A "Level B" or "Level C" entry code is registered. 									
	All operation is unrestricted	The registered entry code has been canceled by an "entry code" menu operation.									
The Entry Code is not set	No entry codes have been registered.										
Fatal error occurred	→ Refer to Subsection 19.24.1 for details.										
All operation is unrestricted	The registered entry code has been canceled by an "entry code" menu operation.										
The Entry Code is not set	No entry codes have been registered.										
Fatal error occurred	→ Refer to Subsection 19.24.1 for details.										

2. PLC Status 2/3

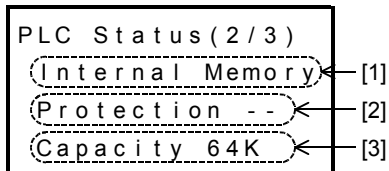

Display Content									
[1]	Program memory type								
	<table border="1"> <thead> <tr> <th>Displayed message</th> <th>Program memory type</th> </tr> </thead> <tbody> <tr> <td>Internal Memory</td> <td>PLC internal RAM memory</td> </tr> <tr> <td>Memory Cassette</td> <td>Memory cassette flash memory</td> </tr> </tbody> </table>	Displayed message	Program memory type	Internal Memory	PLC internal RAM memory	Memory Cassette	Memory cassette flash memory		
	Displayed message	Program memory type							
Internal Memory	PLC internal RAM memory								
Memory Cassette	Memory cassette flash memory								
Memory cassette protect switch status									
[2]	<table border="1"> <thead> <tr> <th>Displayed message</th> <th>Switch Status</th> </tr> </thead> <tbody> <tr> <td>Protection switch --</td> <td>Internal RAM memory (without protect switch)</td> </tr> <tr> <td>Protection switch ON</td> <td>Memory cassette protect switch is ON</td> </tr> <tr> <td>Protection switch OFF</td> <td>Memory cassette protect switch is OFF</td> </tr> </tbody> </table>	Displayed message	Switch Status	Protection switch --	Internal RAM memory (without protect switch)	Protection switch ON	Memory cassette protect switch is ON	Protection switch OFF	Memory cassette protect switch is OFF
	Displayed message	Switch Status							
	Protection switch --	Internal RAM memory (without protect switch)							
Protection switch ON	Memory cassette protect switch is ON								
Protection switch OFF	Memory cassette protect switch is OFF								
[3]	Program memory's max. setting capacity (in step units)								

3. PLC Status 3/3

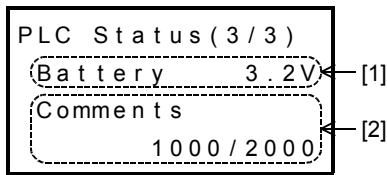

	Display Content
[1]	Battery voltage
[2]	Number of registered comments ([number of registered comments] / [number of parameter-specified comments])

19.16 Scan Time (Scan Time Display)

The scan time's current value, minimum value, and maximum value can be displayed from the "ScanTime" menu.

19.16.1 Scan time display operation

- At the menu screen, use the [+] / [-] buttons to move the cursor to the "ScanTime" item, then press [OK] to display the "scan time screen".
To cancel the operation and return to the "top screen (time display)", press [ESC].
- Press [OK] or [ESC] to return to the "menu screen".

ScanTime	
Curr :	0 . 7ms
Max :	5 . 6ms
Min :	0 . 6ms

19.17 Cassette (Memory Cassette Transfers)

Data transfers (and consistency checks) between the internal RAM memory and a connected memory cassette can be performed from the "Cassette" menu when the PLC is in a STOP state. This menu is disabled, however, if an entry code is registered in the internal RAM. In this case, remove the memory cassette and use the programming tool to cancel the internal RAM's entry code.

Item	Operation Description
Cassette←RAM	Copies internal program memory (RAM) data to a connected memory cassette.
Cassette→RAM	Copies data from a connected memory cassette to the internal program memory (RAM).
Cassette : RAM	Performs a consistency check of the connected memory cassette data and the internal program memory (RAM) data.

11	High-Speed Counters
12	Output Wiring
13	Wiring for Various Uses
14	Test Run, Maintenance, Troubleshooting
15	Input/Output Powered Extension Units
16	Input/Output Extension Blocks
17	Extension Power Supply Unit
18	Other Extension Units and Options
19	Display Module
20	Terminal Block

19.17.1 Transfer from internal RAM to memory cassette (Cassette ← RAM)

- At the menu screen, use the [+] / [-] buttons to move the cursor to the "Cassette" item, then press [OK] to display the "memory cassette transfer screen".
 To cancel the operation and return to the "top screen (time display)", press [ESC].

```
Memory Cassette
> >Cassette ← RAM
    Cassette → RAM
    Cassette : RAM
```

- Use the [+] / [-] buttons to move the cursor to the "Cassette ← RAM" item, then press [OK] to display the screen shown to the right.
 To cancel the operation and return to the "memory cassette transfer screen", press [ESC].

```
Cassette ← RAM
                (Write)
OK → Execute
ESC → Cancel
```

- Press [OK] to begin the transfer.
 Or, press [ESC] to cancel the operation.

Button	Operation Description
ESC	Cancels the operation and returns to the "memory cassette transfer screen".
-	Disabled
+	Disabled
OK	Executes the transfer.

```
Cassette ← RAM
                (Write)
Please wait...
```

- Caution:**
 Do not turn the PLC power off or perform writing from the programming tool while a program is being transferred by a "memory cassette transfer" menu operation, as these actions could destroy the program, causing incorrect operation of the PLC.

- Press [OK] or [ESC] to return to the "memory cassette transfer screen".

- Result and measures to take:

- The transfer is not executed if a "PLC is running" message appears.
 In this case, set the PLC to the STOP state, then perform step 3) described above.

```
PLC is running
```

- The transfer is not executed if a "Transfer failed" message appears.
 In this case, turn the power off, check the memory cassette connection, then attempt the operation again from the first step.

```
Cassette ← RAM
                (Write)
Transfer
failed
```

- The transfer is not executed if a "Memory Cassette is write-protected" message displays.
 In this case, turn the power OFF, set the memory cassette PROTECT switch to OFF, then attempt the operation again from the first step.

```
Memory Cassette
is
write-protected
```

- A "Transfer completed" message appears when the transfer is completed.
 When this message appears, press [OK] or [ESC] to display the "Cassette screen".

```
Cassette ← RAM
                (Write)
Transfer
completed
```

- Press [ESC] to display the "menu screen".

19.17.2 Transfer from memory cassette to internal RAM (Cassette → RAM)

- At the menu screen, use the [+] / [-] buttons to move the cursor to the "Cassette" item, then press [OK] to display the "memory cassette transfer screen".
To cancel the operation and return to the "top screen (time display)", press [ESC].

```
Memory Cassette
  Cassette ← RAM
> >Cassette → RAM<
  Cassette : RAM
```

- Use the [+] / [-] buttons to move the cursor to the "Cassette → RAM" item, then press [OK] to display the screen shown to the right.
To cancel the operation and return to the "memory cassette transfer screen", press [ESC].

```
Cassette → RAM
                ( Read )
OK → Execute
ESC → Cancel
```

- Press [OK] to begin the transfer.
Or, press [ESC] to cancel the operation.

Button	Operation Description
ESC	Cancels the operation and returns to the "memory cassette transfer screen".
-	Disabled
+	Disabled
OK	Executes the transfer.

```
Cassette → RAM
                ( Read )
Please wait...
```

- Caution:**
Do not turn the PLC power off or perform writing from the programming tool while a program is being transferred by a "memory cassette transfer" menu operation, doing so may destroy the program and disorder the PLC.

- Press [OK] or [ESC] to return to the "memory cassette transfer screen".

- Result and measures to take:**

- The transfer is not executed if a "PLC is running" message appears.
In this case, set the PLC to the STOP state, then perform the step 3) operation described above.

```
PLC is running
```

- The transfer is not executed if a "Transfer failed" message appears.
In this case, turn the power off, check the memory cassette connection, then attempt the operation again from the first step.

```
Cassette → RAM
                ( Read )
Transfer
failed
```

- A "Transfer completed" message appears when the transfer is completed.
When this message appears, press [OK] or [ESC] to display the "memory cassette transfer screen".

```
Cassette → RAM
                ( Read )
Transfer
completed
```

- Press [ESC] to display the "menu screen".

11	High-Speed Counters
12	Output Wiring
13	Wiring for Various Uses
14	Test Run, Maintenance, Troubleshooting
15	Input/Output Powered Extension Units
16	Input/Output Extension Blocks
17	Extension Power Supply Unit
18	Other Extension Units and Options
19	Display Module
20	Terminal Block

19.17.3 Memory cassette & internal RAM consistency check (Cassette : RAM)

- At the menu screen, use the [+] / [-] buttons to move the cursor to the "Cassette" item, then press [OK] to display the "memory cassette transfer screen".
 To cancel the operation and return to the "top screen (time display)", press [ESC].

```

Memory Cassette
  Cassette ← RAM
  Cassette → RAM
> >Cassette : RAM
    
```

- Use the [+] / [-] buttons to move the cursor to the "Cassette : RAM" item, then press [OK] to display the screen shown at right.
 To cancel the operation and return to the "memory cassette transfer screen", press [ESC].

```

Cassette : RAM
          (Verify)
OK → Execute
ESC → Cancel
    
```

- Press [OK] to begin the consistency check.
 Or, press [ESC] to cancel the operation.

Button	Operation Description
ESC	Cancels the operation and returns to the "memory cassette transfer screen".
-	Disabled
+	Disabled
OK	Executes the consistency check.

```

Cassette : RAM
          (Verify)
Please wait...
    
```

- Press [OK] or [ESC] to return to the "memory cassette transfer screen".

```

PLC is running
    
```

- Result and measures to take:
 - The consistency check is not executed if a "PLC is running" message appears.
 In this case, stop the PLC, then perform step 3) described above.

- Press [ESC] to display the "menu screen".

```

Cassette : RAM
          (Verify)
Programs match
    
```

```

Cassette : RAM
          (Verify)
Programs
don't match
    
```

19.18 System Information (Restrictions From PLC)

Some of the display module functions require system information settings in order to enable program control of these functions. Functions which require the use of system information are listed below.

- Monitor/test function
 - For hexadecimal display of current value:
→ **Refer to Section 19.21 for the setting procedure.**
 - To use user-registered devices:
→ **Refer to Section 19.19 for the setting procedure.**
- Display screen protect function
→ **Refer to Section 19.22 for details.**
- Operation button ON/OFF information
→ **Refer to Section 19.20 for details.**
- User message display function
→ **Refer to Section 19.23 for details.**

19.18.1 System information list

Special data register D8300 and D8301 devices with first numbers specified are assigned as system information devices (data register, auxiliary relay). The data register (excluding special data register) should be specified at the system information's "system signal 1", and the auxiliary relay (excluding special auxiliary relay) should be specified at the system information's "system signal 2". Both D8300 and D8301 have default settings of "-1".

→ **Refer to Section 19.19 to 19.23 for explanations of each system signal.**

1. System signal 1

Special data register	System Information	Description	Reference
D8300 = K□□ Occupies 41 points	D□□	Devices for user-registered device settings Only data registers can be specified for user-registered devices.	User-registered device 1 type
	D□□+1		User-registered device 1 No.
	D□□+2		User-registered device 2 type
	D□□+3		User-registered device 2 No.
	D□□+4		User-registered device 3 type
	D□□+5		User-registered device 3 No.
	D□□+6		User-registered device 4 type
	D□□+7		User-registered device 4 No.
	D□□+8	Device for display screen protect function	Section 19.22
	D□□+9	Device where user message display character strings are saved. Use either character data or the data shown below.	Section 19.23
?	<ul style="list-style-type: none"> • Alphanumeric: 20H to 7DH, A1H to DFH ASCII code • Japanese: Shift JIS code 		
D□□+40			

2. System signal 2

Special data register	System Information	Description	Reference
D8301 = K△△△ Occupies 7 points	M△△	[OK] button ON/OFF	Section 19.20
	M△△+1	[ESC] button ON/OFF	
	M△△+2	[-] button ON/OFF	
	M△△+3	[+] button ON/OFF	
	M△△+4	User message display command	Section 19.23
	M△△+5	Device for specifying the "Monitor/Test" menu's current value and setting the value display format (hexadecimal or decimal).	Section 19.21
	M△△+6	Display screen information	ON during "user-registered device monitoring screen" or "user message" display. Section 19.19 and Section 19.23

19.18.2 System information setting program example

The following is a program example in which the system information has been assigned to D50 to D90 and M50 to M56.

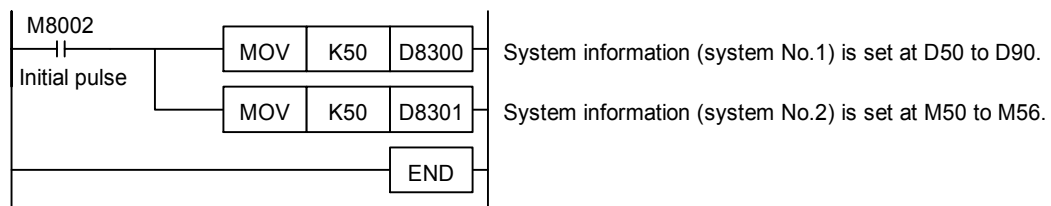

19.19 User (User-Registered Device Setting)

The procedure for specifying the devices which display as "User" at the "Monitor/Test" menu is explained below. The user-registered devices are specified by writing the "device type" and "device No." at "D□□ to D□□+7" in the system information (system signal 1).

→ Refer to Section 19.8 for operation.

→ Refer to Section 19.18 for system information setting.

→ Refer to Subsection 19.19.3 to 19.19.5 for program examples.

19.19.1 System information - user-registered device setting

1. System signal 1

User-Registered Device No.	System Information	Description	Setting Value
1	D□□	Device type	D□□= K7: Data register [D] (16-bit) D□□= K8: Data register [D] (32-bit)
	D□□+1	Device No.	When D□□ = K7, D□□ + 1 = K0 to K8511 When D□□ = K8, D□□ + 1 = K0 to K7998, K8000 to K8510
2	D□□+2	Device type	D□□+2= K7: Data register [D] (16-bit) D□□+2= K8: Data register [D] (32-bit)
	D□□+3	Device No.	When D□□ = K7, D□□ + 3 = K0 to K8511 When D□□ = K8, D□□ + 3 = K0 to K7998, K8000 to K8510
3	D□□+4	Device type	D□□+4= K7: Data register [D] (16-bit) D□□+4= K8: Data register [D] (32-bit)
	D□□+5	Device No.	When D□□ = K7, D□□ + 5 = K0 to K8511 When D□□ = K8, D□□ + 5 = K0 to K7998, K8000 to K8510
4	D□□+6	Device type	D□□+6= K7: Data register [D] (16-bit) D□□+6= K8: Data register [D] (32-bit)
	D□□+7	Device No.	When D□□ = K7, D□□ + 7 = K0 to K8511 When D□□ = K8, D□□ + 7 = K0 to K7998, K8000 to K8510

2. System signal 2

System Information	Setting Content	Display Screen Status
M△△+6	ON	"User-registered device" screen, or "user message" screen is displayed.
	OFF	Other screen is displayed.

19.19.2 Precaution when setting 3 or fewer devices

When 3 or fewer devices are set as user-registered devices, the "type" setting for unused devices should be set to a value other than 7 and 8.

→ Refer to Subsection 19.19.4 for a program example.

19.19.3 Program example 1 (when 4 devices are displayed as user-registered devices)

Use this program example as a reference when setting 4 devices as user-registered devices.

1. Operation

In this program example, the 4 devices shown in the table below are set as user-registered devices, with a hexadecimal format specified for the current value display.

- 1) The hexadecimal display format applies only to current values which display at the "user-registered device" menu. Other current values display in a decimal format.
- 2) In this program example, system information is assigned from D50 to D90 and from M50 to M56.

User-Registered Device No.	Devices Set As User-Registered Devices	Data Length	Display Format
1	D100 (D101)	32Bit	Hexadecimal
2	D102	16Bit	
3	D103	16Bit	
4	D104	16Bit	

2. Program

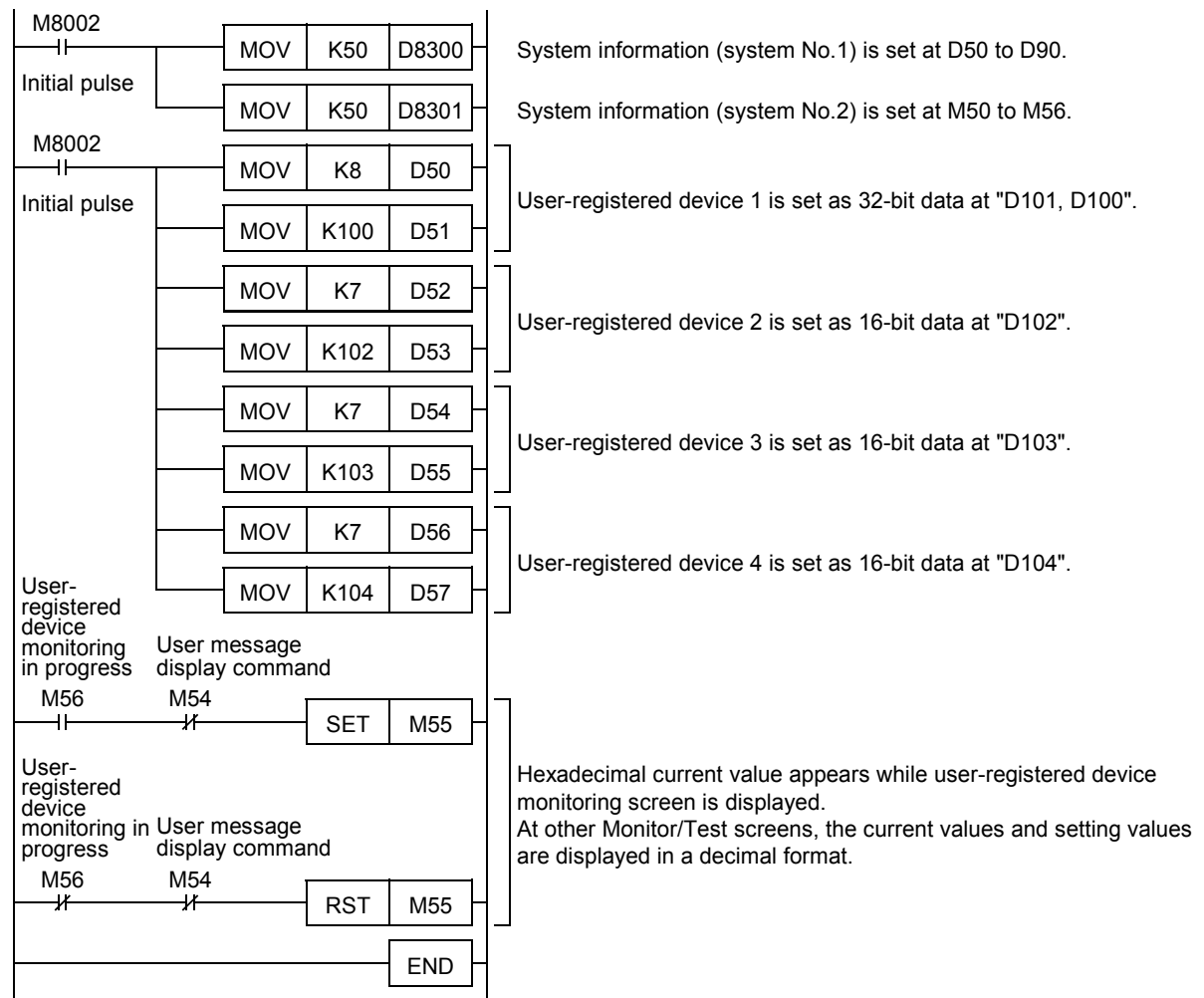

19.19.4 Program example 2 (when 3 or fewer devices are displayed as user-registered devices)

Use this program example as a reference when setting 3 or fewer devices as user-registered devices.

1. Precaution When Setting 3 Or Fewer Devices

When 3 or fewer devices are set as user-registered devices, the "type" setting for unused devices should be set to a value other than 7 and 8.

2. Operation

In this program example, the 3 devices shown in the table below are set as user-registered devices, with a hexadecimal format specified for the current value display.

- 1) The hexadecimal display format applies only to current values which are displayed at the "user-registered device" menu. Other current values are displayed in a decimal format.
- 2) In this program example, system information is assigned from D50 to D90 and from M50 to M56.

User-Registered Device No.	Devices Set As User-Registered Devices	Data Length	Display Format
1	D100 (D101)	32-Bit	Hexadecimal
2	D102	16-Bit	
3	D103	16-Bit	

3. Program

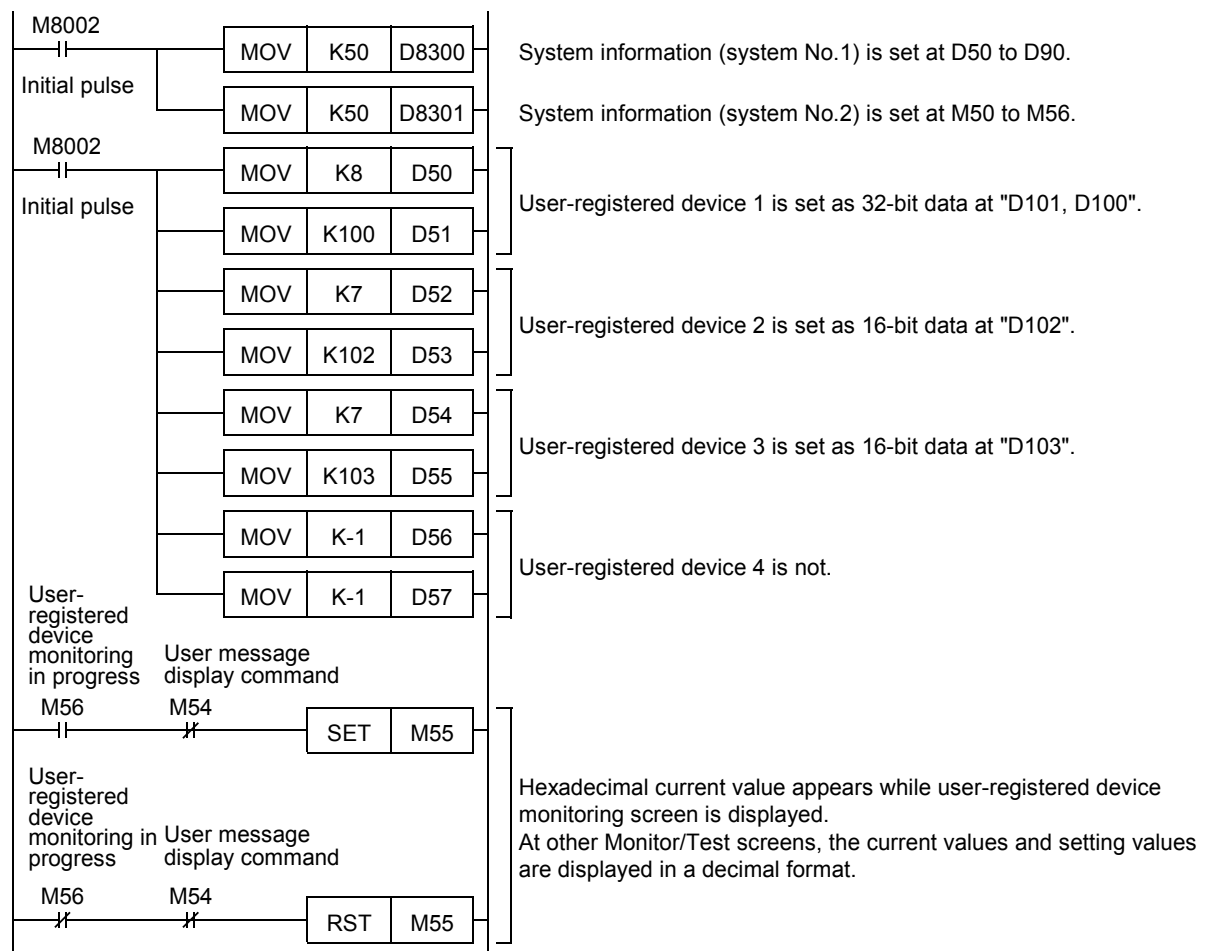

11	High-Speed Counters
12	Output Wiring
13	Wiring for Various Uses
14	Test Run, Maintenance, Troubleshooting
15	Input/Output Powered Extension Units
16	Input/Output Extension Blocks
17	Extension Power Supply Unit
18	Other Extension Units and Options
19	Display Module
20	Terminal Block

19.19.5 Program example 3 (when 5 or more devices are displayed as user-registered devices)

Use this program example as a reference when setting 5 or more devices as user-registered devices.

1. Operation

In this program example, the 7 devices shown in the table below are set as user-registered devices, with the current value display format set individually for each device.

- 1) The display formats specified here apply only to current values which appear at the "user-registered device" menu. Other current values appear in decimal format.
- 2) In this program example, system information is assigned from D50 to D90 and from M50 to M56.

User-Registered Device No.	Devices Set As User-Registered Devices	Data Length	Display Format
1	D100 (D101)	32-Bit	Hexadecimal
2	D102	16-Bit	Decimal
3	D103	16-Bit	Decimal
4	D104	16-Bit	Decimal
5	D200	16-Bit	Hexadecimal
6	D210	16-Bit	Decimal
7	D201	16-Bit	Hexadecimal

2. Program

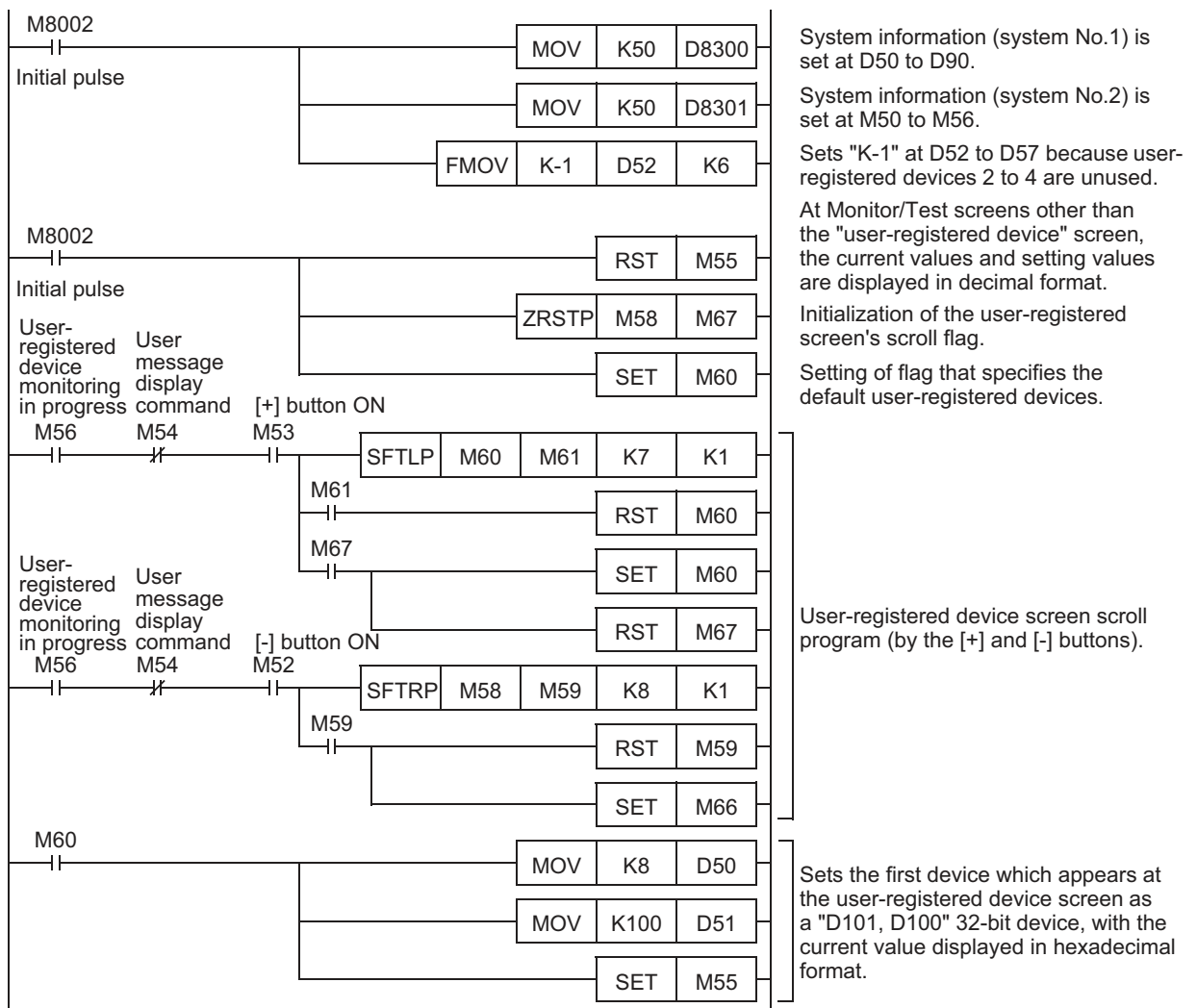

Continued on next page

Continued from previous page

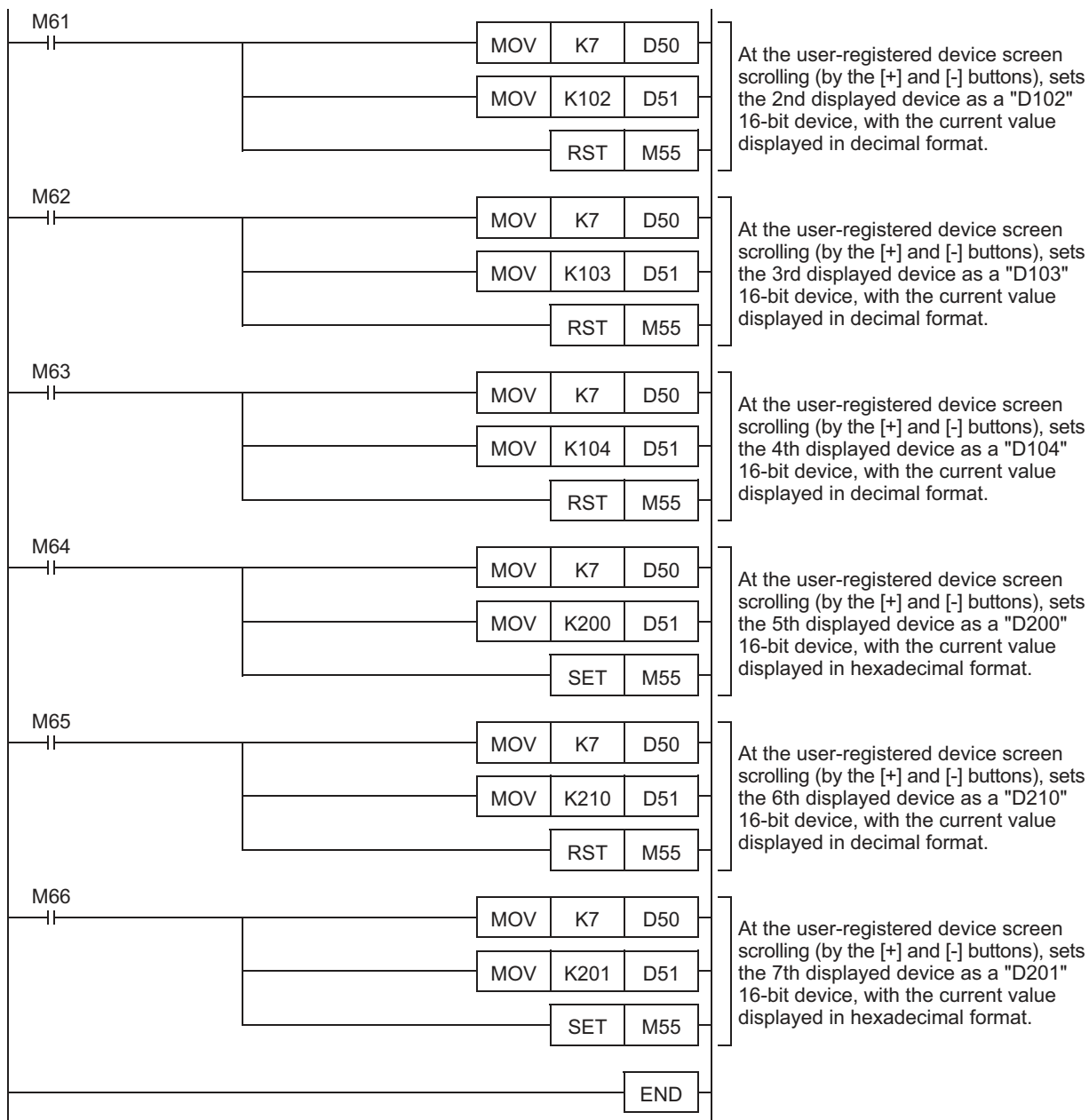

11	High-Speed Counters
12	Output Wiring
13	Wiring for Various Uses
14	Test Run, Maintenance, Troubleshooting
15	Input/Output Powered Extension Units
16	Input/Output Extension Blocks
17	Extension Power Supply Unit
18	Other Extension Units and Options
19	Display Module
20	Terminal Block

19.20 Operation Button ON/OFF Information

Operation button ON/OFF information can be monitored at the system information (system signal 2) "M△△ to M△△+3" while the PLC is running. Various applications of this function are described below.

→ Refer to Section 19.18 for system information setting.

19.20.1 Various applications

1. Operation button function checks

The programming tool can be used to monitor the system information's (system signal 2) "operation button ON/OFF information", to verify that operation buttons are functioning properly.

2. User-registered device changes

The system information's (system signal 2) "display screen information" and "operation button ON/OFF information" can be used together to change and display 4 or more user-registered devices.

→ Refer to Section 19.19 for the user-registered device setting procedure.

→ Refer to Subsection 19.19.3 to 19.19.5 for program examples.

3. User message changes

The system information's (system signal 2) "display screen information" and "user message display command", and "operation button ON/OFF information" can be used together while a user message is displayed in order to change (by [+] / [-] button operation) the user message that the program displays.

→ Refer to Section 19.23 user message display function.

→ Refer to Subsection 19.23.4 to 19.23.6 for program examples.

19.20.2 System information - operation button ON/OFF information

1. System signal 1

System signal 1 has no system information related to this function.

2. System signal 2

System Information	Status	Description
M△△	ON	[OK] button is pressed.
	OFF	[OK] button is not pressed.
M△△+1	ON	[ESC] button is pressed.
	OFF	[ESC] button is not pressed.
M△△+2	ON	[-] button is pressed.
	OFF	[-] button is not pressed.
M△△+3	ON	[+] button is pressed.
	OFF	[+] button is not pressed.

19.21 Specifying a Hexadecimal Current Value Display Format

The procedure for specifying a hexadecimal display format for current values which display at the "Monitor/Test" menu explained below. The display format is specified by the system information's (system signal 2) "M□□+5" ON/OFF status.

The display formats which correspond to the ON and OFF statuses are shown in Subsection 18.21.1 below. The display format should either be fixed as decimal or hexadecimal. Switching between the two should be possible by an external operation.

→ Refer to Section 19.18 for system information setting.

19.21.1 System information - specifying a hexadecimal current value display format

1. System signal 1

System signal 1 is unrelated to this function.

2. System signal 2

System Information	Setting Content	Display Format	Display Subjects
M△△+5	ON	Hexadecimal	Timer (T) [current value], counter (C) [current value], data register (D) [16-bit/32-bit], extended register (R) [16-bit/32-bit], and extended file register (ER) [16-bit/32-bit]
	OFF	Decimal	

19.21.2 Program example 1 (specifying a hexadecimal data display format)

The following program example specifies a hexadecimal display format for current values and setting values which display at the "Monitor/Test" screen. In this program example, system information is assigned from D50 to D90 and from M50 to M56.

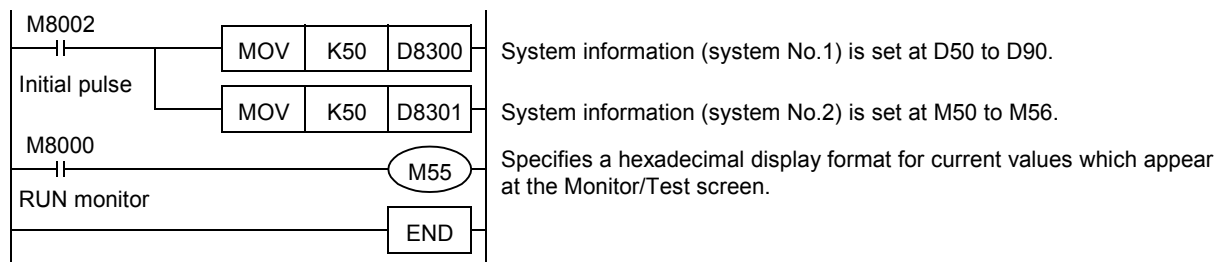

19.21.3 Program example 2 (specifying a decimal data display format)

The following program example specifies a decimal display format for current values and setting values which appear at the "Monitor/Test" screen. In this program example, system information is assigned from D50 to D90 and from M50 to M56.

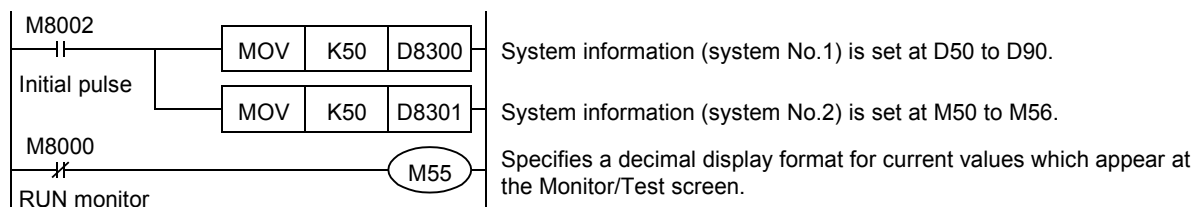

19.22 Display Screen Protect Function

The display screen protect function prevents accidental operation by restricting the display module functions. The display screen protect function is enabled when no entry code is registered. The display screen protect function's protection level is specified in the system information (system signal 1) "D□□+8".

- Refer to Section 19.4 for display module function.
- Refer to Subsection 19.13.5 for the "entry code cancel" procedure.
- Refer to Section 19.18 for system information setting.

19.22.1 Keyword (Entry code) & display screen protect function levels and corresponding restrictions

If an entry code has been registered, that entry code related restriction takes priority over the "display screen protect function"

- ✓ : Usable
- △ : Timer and counter settings cannot be changed
- ▲ : Only monitor function is usable (test function is not available)
- : Unusable

Function Name	Entry code			Display Screen Protect			
	None	All online operations prohibited	Writing prohibited	Reading/writing prohibited	None	1	2
16-digit entry code *1 setting-->	None	A (All operations prohibited)	B (Read/Incorrect write protection)	C (Erroneous write prohibited)			
8-digit entry code setting (level) -->							
Top screen (time display)	✓	✓	✓	✓	✓	✓	✓
Monitor/Test	Device	□	△	△	✓	□	▲
	User (User-registered device)	✓	□	✓	✓	□	▲
ScanTime (Scan time display)	✓	□	✓	✓	✓	□	✓
PLC status	✓	□	✓	✓	✓	□	✓
ErrorCheck	✓	□	✓	✓	✓	□	✓
User message display	✓	✓	✓	✓	✓	✓	✓
Display screen protect function	✓	□	□	□	✓	✓	✓
Menu display language setting	✓	□	✓	✓	✓	□	□
Contrast adjustment	✓	□	✓	✓	✓	□	□
Time	Display	✓	✓	✓	✓	□	✓
	Setting	✓	□	✓	✓	□	□
Entry code (cancel)	-	✓	✓	✓	✓	□	□
Clear all device (Device all-clear)	✓	□	✓	✓	✓	□	□
Memory cassette transfer	✓	□	□	□	✓	□	□

*1. Customer keyword / permanent PLC lock included. However, permanent PLC lock does not have a keyword input.
FX3U PLC Ver. 2.61 or later supports the customer keyword and permanent PLC lock.

19.22.2 Relationship between keyword (entry code) & display screen protect function

If the PLC's entry code registration function is used, that entry code related restriction takes priority over the display module's "display screen protect function". The relationship between entry codes and the display screen protect function is shown below.

Entry code registration	Entry code Status	Display Screen Protect Status	Function Restrictions
Entry code is registered	Entry code is not canceled	Entry code is being used	Restriction of functions is according to the entry code level.
		Entry code is not being used	
	Entry code is canceled	Entry code is being used	All functions are enabled (no restrictions).
		Entry code is not being used	
Entry code is not registered	Entry code is being used		Restriction of functions is according to the display screen protect function.
	Entry code is not being used		All functions are enabled (no restrictions).

19.22.3 Keyword (Entry code) levels

1. For versions prior to Ver. 2.20

8-Digit Entry code Level	Entry code Content	Entry code Input Example
A (All operations prohibited)	8-digit hexadecimal value beginning with "A" or "0 to 9" numeral.	0ABCDEF2 AABCD345
B (Read/Incorrect write protection)	8-digit hexadecimal value beginning with "B".	B1234567 BABCDEF7
C (Erroneous write prohibited)	8-digit hexadecimal value beginning with "C".	C8904567 CDEF567F

2. For Ver. 2.20 and later

16-digit entry codes^{*1} are used.

If an 8-digit entry code is specified, processing occurs in the same manner as in versions prior to Ver. 2.20.

16-Digit Entry code Setting Content	Entry code Content	Entry code Input Example
All online operations prohibited	"A to F", "0 to 9" 16-digit value.	0ABCDEF262297529 AABCDEBF34523724
Writing prohibited	"A to F", "0 to 9" 16-digit value.	B123456789012345 7ABCDEF73DAEB93A
Reading/writing prohibited	"A to F", "0 to 9" 16-digit value.	2890445234817567 CDEF567FABDFEA46

*1. Customer keyword / permanent PLC lock included. However, permanent PLC lock does not have a keyword input.
FX3U PLC Ver. 2.61 or later supports the customer keyword and permanent PLC lock.

11	High-Speed Counters
12	Output Wiring
13	Wiring for Various Uses
14	Test Run, Maintenance, Troubleshooting
15	Input/Output Powered Extension Units
16	Input/Output Extension Blocks
17	Extension Power Supply Unit
18	Other Extension Units and Options
19	Display Module
20	Terminal Block

19.22.4 System information - display screen protect function

1. System signal 1

System Information	Setting Content (Level)	Function Restriction Summary
D□□+8	1	All functions except the "user message display" and "top screen (time display)" functions are disabled.
	2	The following functions are disabled: "monitor/test's 'test' function", "device all-clear", "time change", "contrast setting", "memory cassette transfer", and "menu display language setting".
	Other values	All functions are enabled.

2. System signal 2

System signal 2 is unrelated to this function.

19.22.5 Program example (screen protect function setting)

In this program example, the display screen protect function is set to "level 2". Use this program as a reference when other level settings are specified.

In this program example, system information is assigned from D50 to D90 and from M50 to M56.

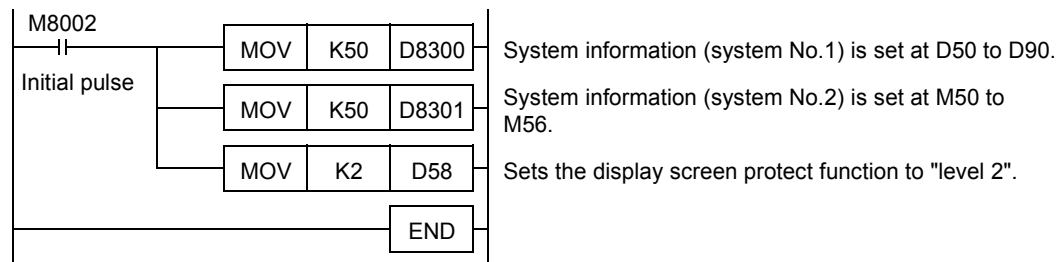

19.22.6 Pointers for using the display screen protect function

The display screen protect function settings should be specified in a sequence program.

- The protect function is enabled by using the display module's "monitor/test function" to change the system information's (system signal 1) "D□□+8" current value to "1" or "2".
- Once the setting is made, it cannot be canceled from the display module.
- To cancel the setting, use the programming tool to change the system information's (system signal 1) "D□□+8" current value to a value other than "1" and "2".
 If the system information's (system signal 1) "D□□+8" is set in a general purpose data register, however, the display screen protect function can be canceled by turning the power off, then on again.

19.23 User Message Display Function

The user message display function allows a user-prepared message to appear in place of the "top screen (time display)".

The [OK] button is then pressed to switch from the "user message screen" to the "menu screen".

If using fixed user messages, the messages (created in GX Developer's "device memory" window) should be saved individually at D□□+9 to D□□+40 of the file register (D), extended register (R), and extended file register (ER).

→ Refer to Section 19.18 for system information setting.

→ Refer to Subsection 19.23.7 for character data input.

19.23.1 System information - user message display function

1. System signal 1

System Information	Description
D□□+9	Device where the user message character string is saved.
ι	
D□□+40	

1) Displayable Characters & Codes

Character Type	Code
Alphanumeric	20H to 7DH, A1H to DFH ASCII code
Japanese	Shift JIS Level 1-, 2

2) System information's (system signal 1) D□□+9 to D□□+40 and display position

		Row (horizontal character position)															
		[1]	[2]	[3]	[4]	[5]	[6]	[7]	[8]	[9]	[10]	[11]	[12]	[13]	[14]	[15]	[16]
Line (vertical character position)	1	D□□+9		D□□+10		D□□+11		D□□+12		D□□+13		D□□+14		D□□+15		D□□+16	
		Lower order	Higher order	Lower order	Higher order	Lower order	Higher order	Lower order	Higher order	Lower order	Higher order	Lower order	Higher order	Lower order	Higher order	Lower order	Higher order
	2	D□□+17		D□□+18		D□□+19		D□□+20		D□□+21		D□□+22		D□□+23		D□□+24	
		Lower order	Higher order	Lower order	Higher order	Lower order	Higher order	Lower order	Higher order	Lower order	Higher order	Lower order	Higher order	Lower order	Higher order	Lower order	Higher order
	3	D□□+25		D□□+26		D□□+27		D□□+28		D□□+29		D□□+30		D□□+31		D□□+32	
		Lower order	Higher order	Lower order	Higher order	Lower order	Higher order	Lower order	Higher order	Lower order	Higher order	Lower order	Higher order	Lower order	Higher order	Lower order	Higher order
	4	D□□+33		D□□+34		D□□+35		D□□+36		D□□+37		D□□+38		D□□+39		D□□+40	
		Lower order	Higher order	Lower order	Higher order	Lower order	Higher order	Lower order	Higher order	Lower order	Higher order	Lower order	Higher order	Lower order	Higher order	Lower order	Higher order

2. System signal 2

System Information	Setting Content	Screen Display
M△△+4	ON	User message display command. This command is enabled only when the "top screen (time display)" is displayed.
	OFF	Cancels the user message display, and displays the "top screen (time display)".
M△△+6	ON	ON when the "user-registered device monitor screen" or the "user message screen" is displayed.
	OFF	OFF when other screens are displayed.

19.23.2 Shift JIS code arrangement precautions

To prevent garbled characters when a 2-byte character (shift JIS code) arrangement extends into the next line, the system replaces those characters with 2 spaces.

[Ex] If a full-size character arrangement exists at D□□+16 (higher order) + D□□+17 (lower order), spaces will display at those positions. Therefore, the use of full-size characters (shift JIS code) should be avoided at the shaded areas shown in the above table.

19.23.3 Displaying a word device current value as a message

A numeric value can be displayed at the user message by combining BCD (FNC 18), ASCII (FNC 82), and BMOV (FNC 15) instructions.

→ Refer to Subsection 19.23.6 for a program example.

19.23.4 Program example 1 (user messages display switching)

The following program example is for user messages that appear according to the ON/OFF status of auxiliary relays M100 to M102.

Note that user messages do not appear when a screen other than the "top screen (time display)" is displayed.

1. Operation

The 3 messages shown below appear according to the ON/OFF status of auxiliary relays M100 to M102. When auxiliary relays are ON simultaneously, the messages appear in the No.1 --> No.2 --> No.3 order. The following is a program example in which the system information has been assigned from D50 to D90 and from M50 to M56.

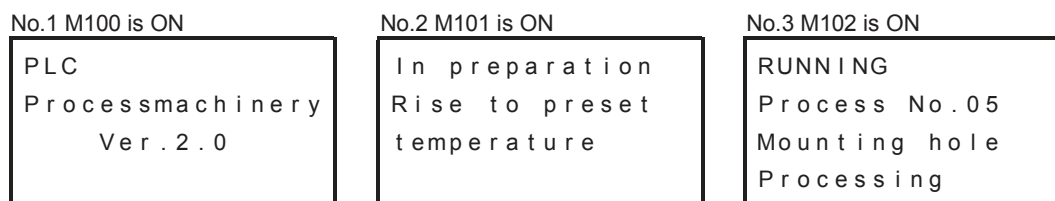

2. Character data

User message data to be displayed is created in GX Developer, and is assigned to the file registers shown below.

→ Refer to Subsection 19.23.7 for character data input.

Message No.	File Register Where Saved
1	D1000 to D1031
2	D1032 to D1063
3	D1064 to D1095

3. Program

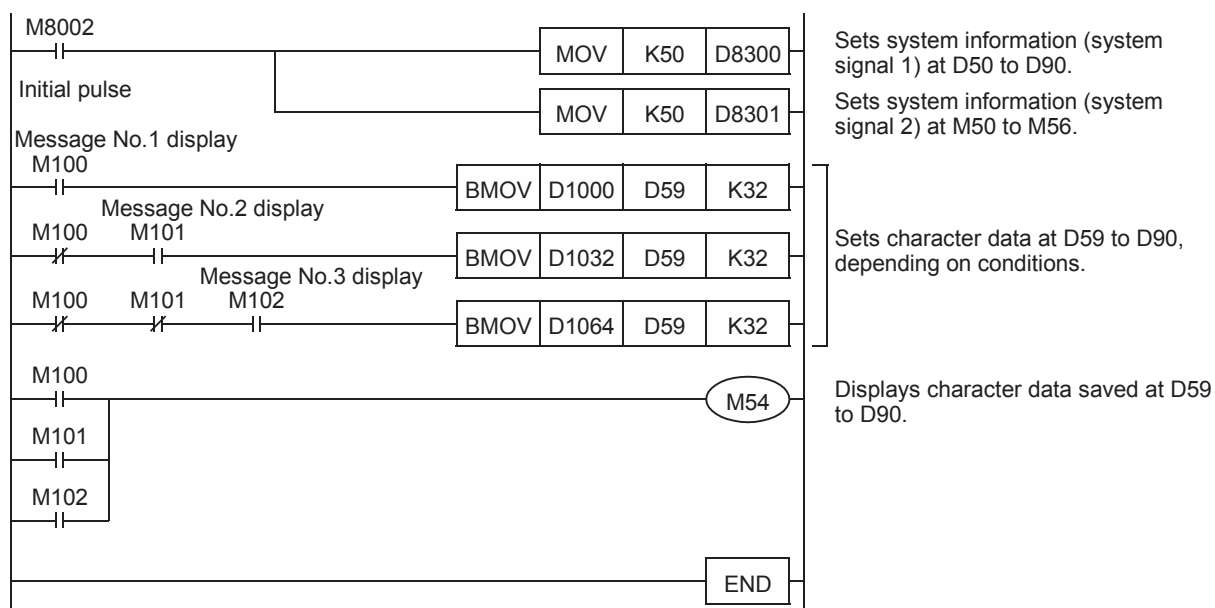

19.23.5 Program example 2 ([+] / [-] buttons for user message switching)

The following is a program example in which the [+] / [-] buttons are used to switch the displayed user message. Note that user messages do not appear when a screen other than the "top screen (time display)" is displayed.

1. Operation

The No.1 message shown below appears when auxiliary relay M100 switches on, and the [+] / [-] buttons can be used at that time to switch to the other messages as shown below. The system information is assigned from D50 to D90 and from M50 to M56.

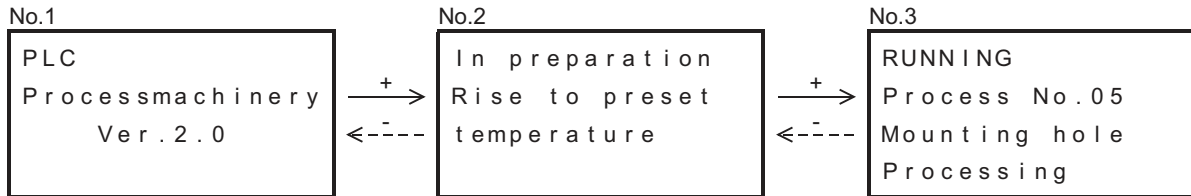

2. Character data

User message data to be displayed is created in GX Developer, and is assigned to the file registers shown below. → Refer to Subsection 19.23.7 for character data input.

Message No.	File Register Where Saved
1	D1000 to D1031
2	D1032 to D1063
3	D1064 to D1095

3. Program

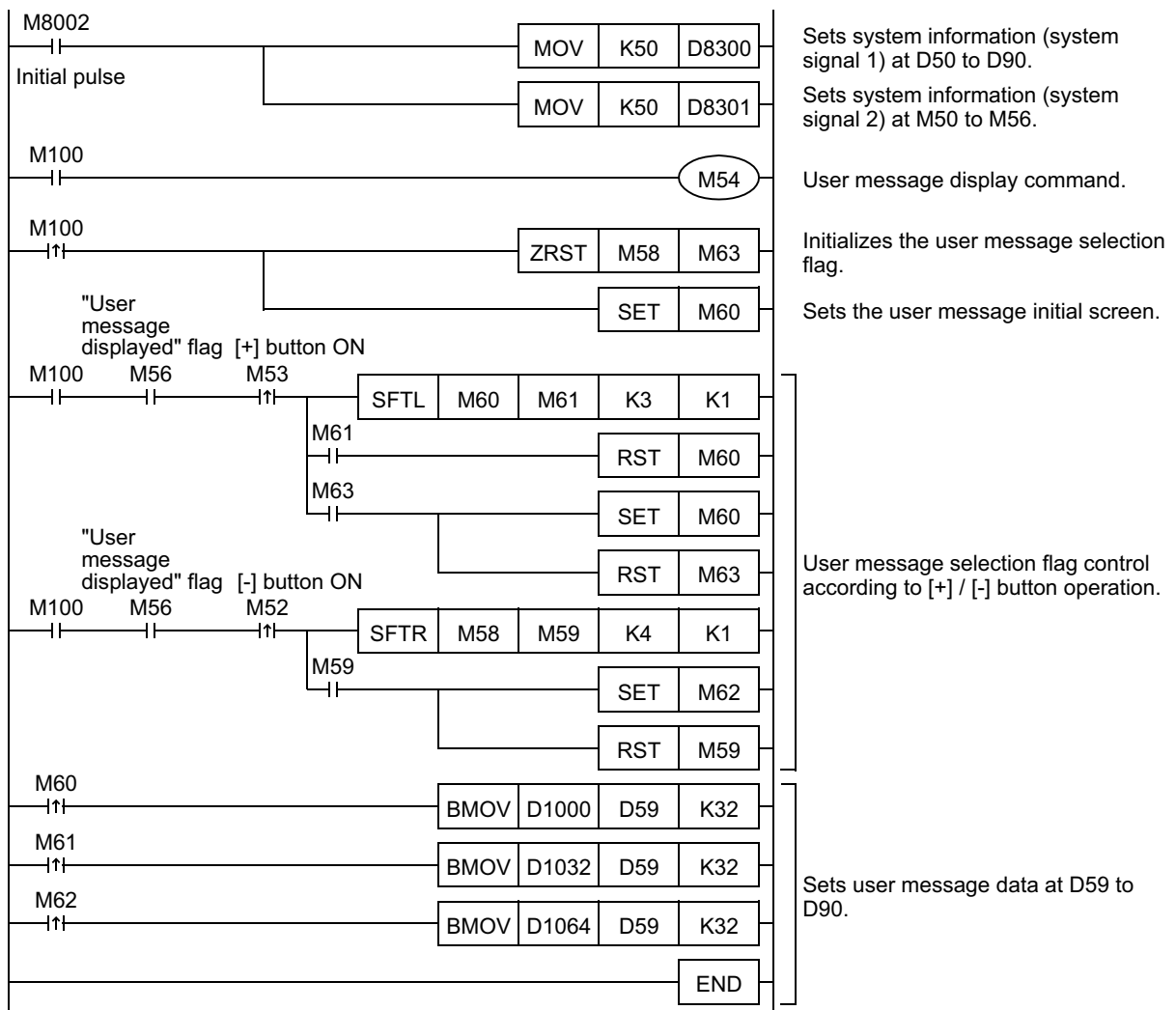

- 11 High-Speed Counters
- 12 Output Wiring
- 13 Wiring for Various Uses
- 14 Test Run, Maintenance, Troubleshooting
- 15 Input/Output Powered Extension Units
- 16 Input/Output Extension Blocks
- 17 Extension Power Supply Unit
- 18 Other Extension Units and Options
- 19 Display Module
- 20 Terminal Block

19.23.6 Program example 3 (user messages plus data display)

The following is a program example in which the counter's current value appears at the user message.
Note that user messages do not appear when a screen other than the "top screen (time display)" is displayed.

1. Operation

The message shown below appears when auxiliary relay M100 switches on.
In this program example, the system information is assigned from D50 to D90 and from M50 to M56.

< P r o d u c t i o n >	
Target	* 1
Production	* 1
Remaining	* 1

- *1. The current values of the devices shown below appear as the target quantity, the production quantity, and the remaining quantity.

Item	Device	Remarks
Target	D200	Specifies the C0 setting.
Production	C0	Counts the number of M101 ON operations.
Remaining	D201	Remaining (D201) = target (D200) - production (C0).

2. Displaying a word device current value as a message

A numeric value can be displayed at the user message by combining BCD (FNC 18), ASCII (FNC 82), and BMOV (FNC 15) instructions, etc.

3. Character data

User message data to be displayed is created in GX Developer, and is assigned to file registers D1000 to D1031.
→ Refer to Subsection 19.23.7 for character data input.

4. Program

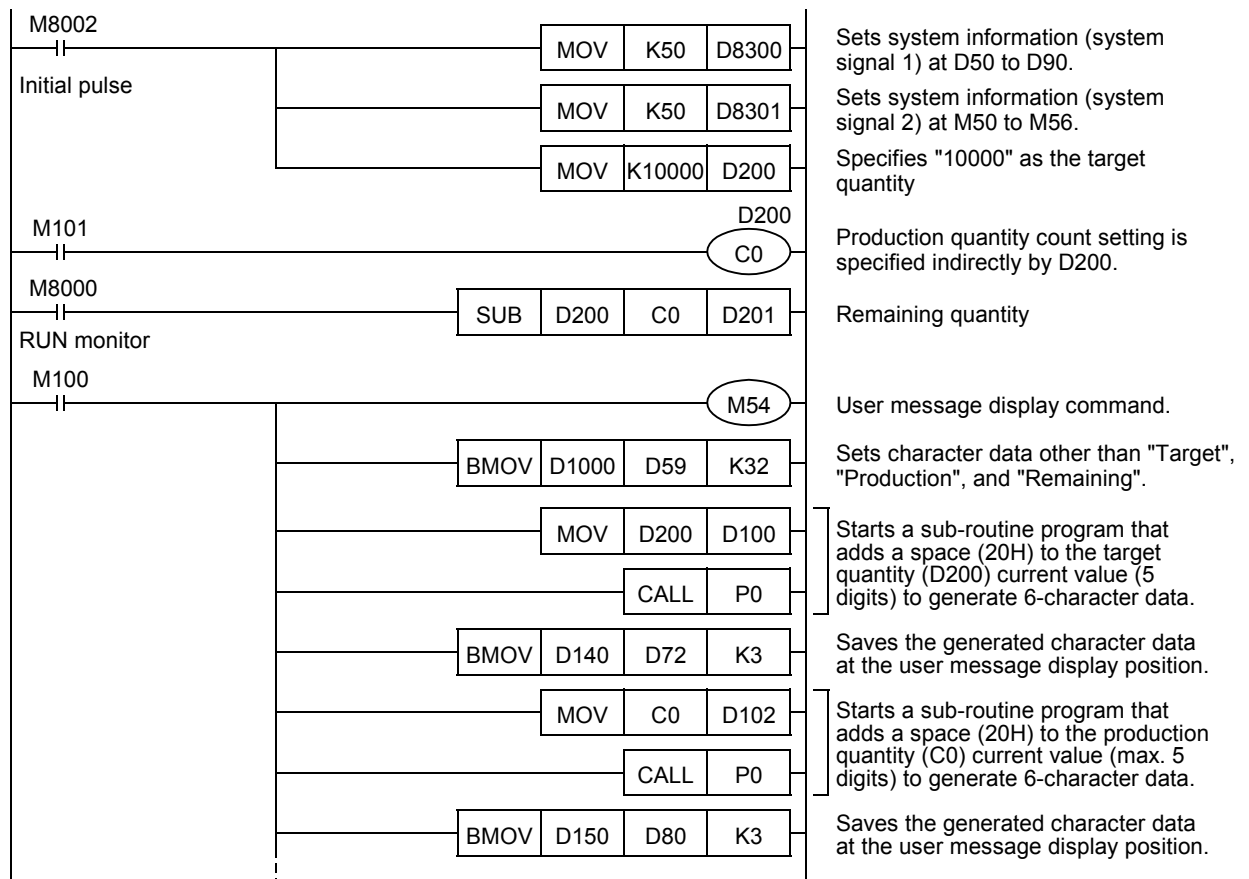

Continued on next page

Continued from previous page

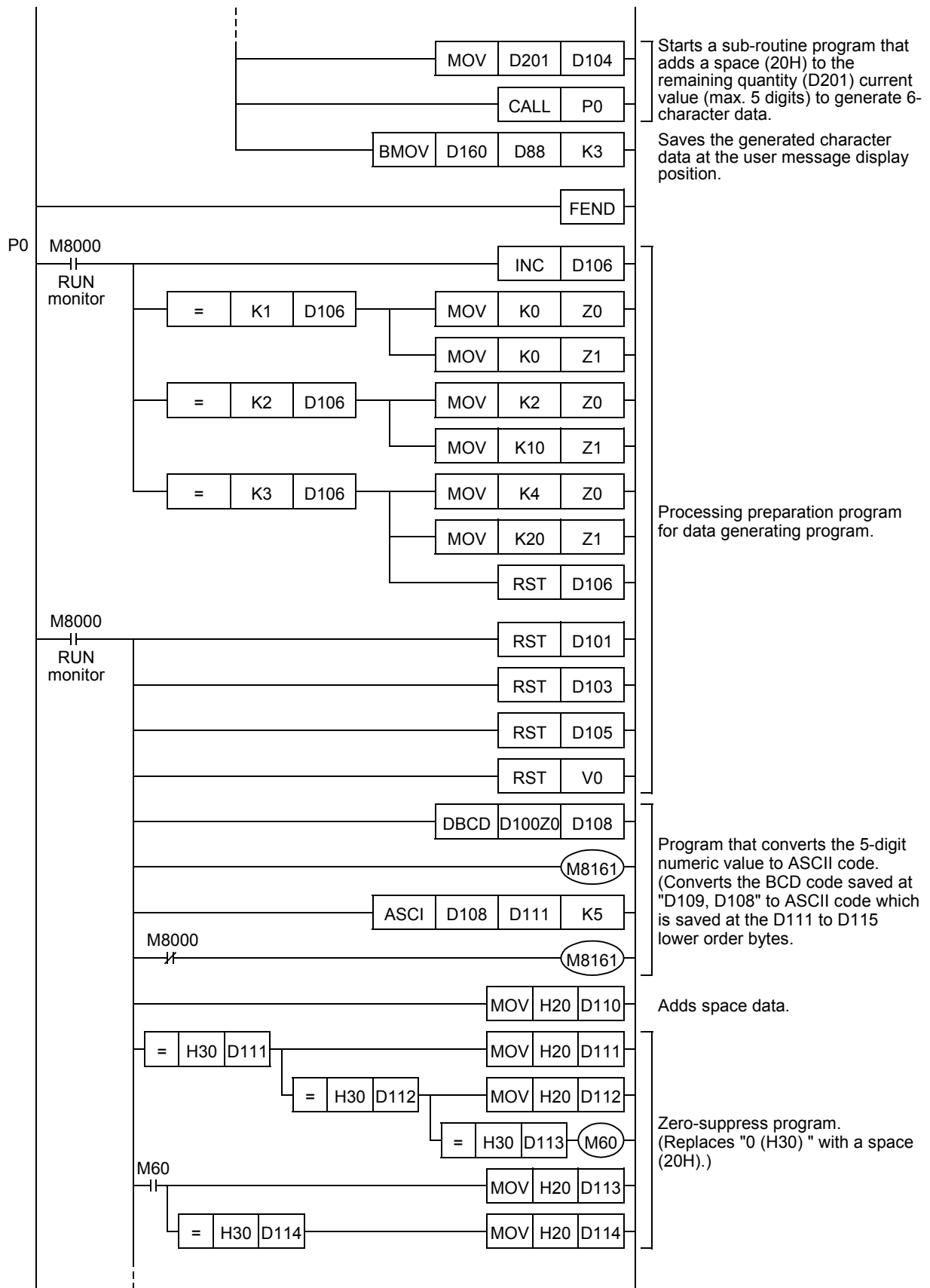

Continued on next page

11	High-Speed Counters
12	Output Wiring
13	Wiring for Various Uses
14	Test Run, Maintenance, Troubleshooting
15	Input/Output Powered Extension Units
16	Input/Output Extension Blocks
17	Extension Power Supply Unit
18	Other Extension Units and Options
19	Display Module
20	Terminal Block

Continued from previous page

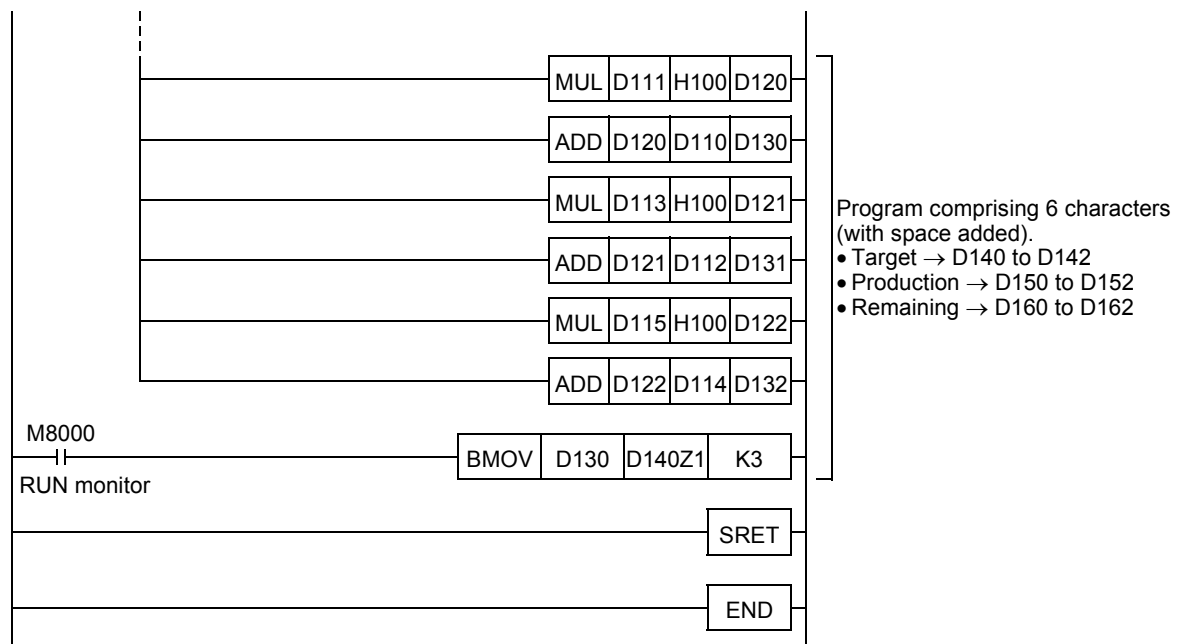

19.23.7 Character data input procedure

User messages are entered and assigned to file registers in advance, using GX Developer.
Messages are displayed by a file register → data register transfer, with the message being created in place of the numeric values, etc.
32 data register points are assigned to each message.

1 Starting GX Developer

To start up GX Developer, click the Windows® [Start] button, then click [Programs] - [MELSOFT Application] - [GX Developer].

2 Setting The PLC Model Name

Set the "PLC series" and the "PLC Type" settings as shown below.

Required Setting Items	Setting Content
PLC series	FXCPU
PLC Type	FX3U(C)*1

*1. For Ver. 8.18U to 8.24A of GX Developer, the PLC type is FX3UC.

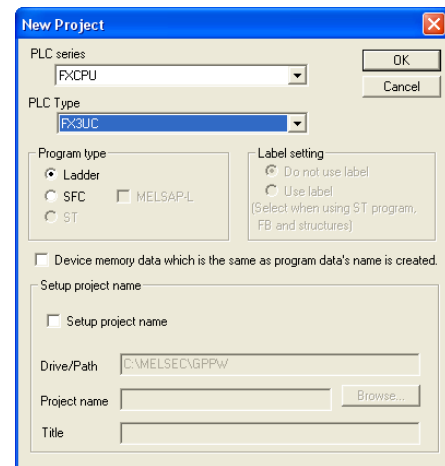

3 Parameter Settings

To specify the parameter settings, select "PLC parameter" from the project data list.

If the project data list does not display, click the toolbar's [Display] - [Project data list] items.

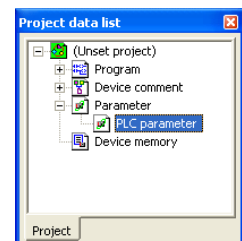

Click the "Memory capacity" tab to perform file register assignments.

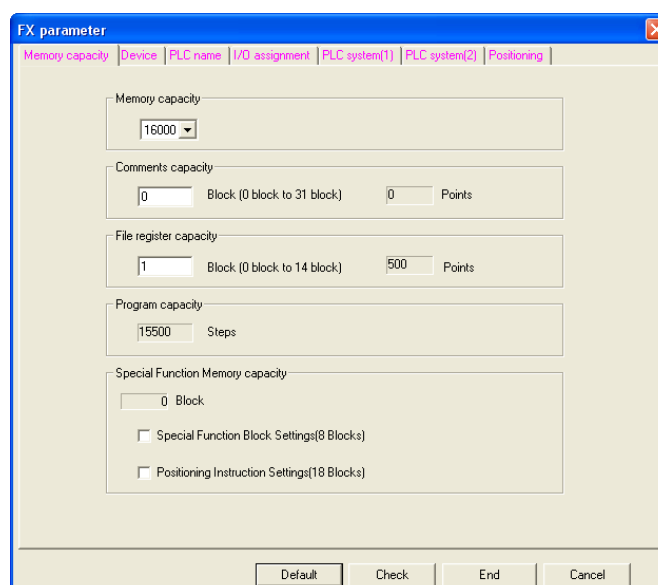

11	High-Speed Counters
12	Output Wiring
13	Wiring for Various Uses
14	Test Run, Maintenance, Troubleshooting
15	Input/Output Powered Extension Units
16	Input/Output Blocks
17	Extension Power Supply Unit
18	Other Extension Units and Options
19	Display Module
20	Terminal Block

4 Selecting The File Register

1. From the project data list, select "Device memory", then right-click and select [New] at the submenu.
2. The "New" dialog box then appears. Click [OK]

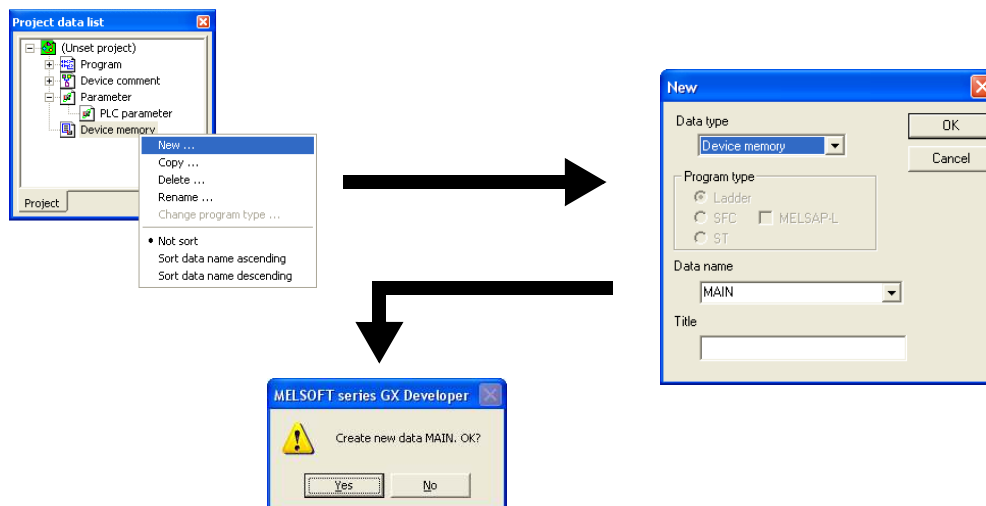

A confirmation dialog box then appears. Click [Yes].

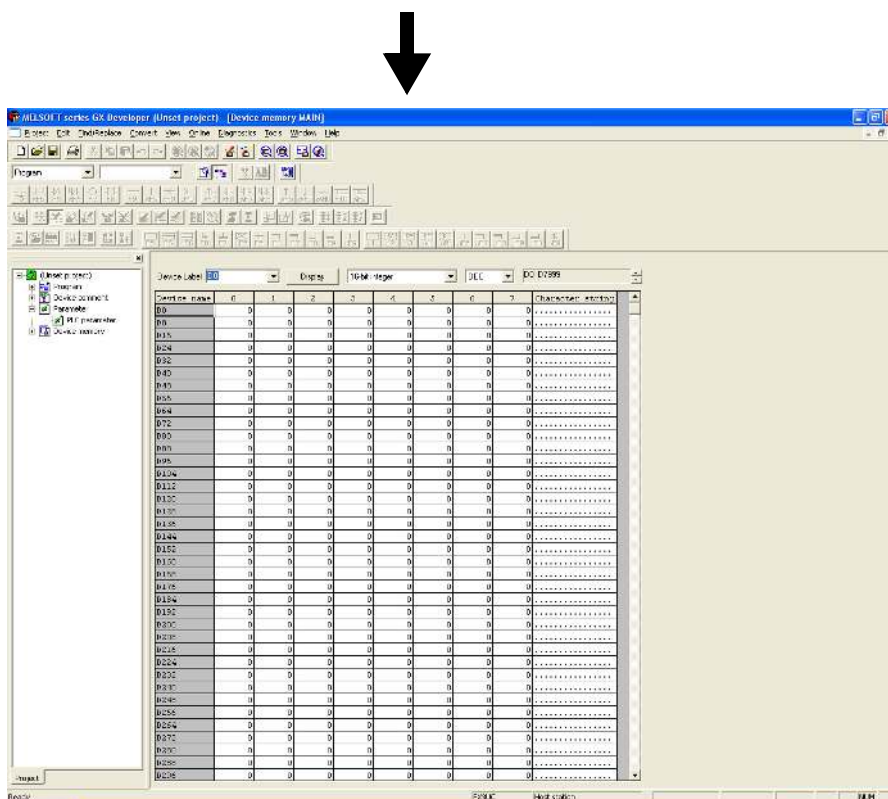

3. Enter "D1000" at the device, then click [Display].
(The first No. of the file register is selected.)
4. At the 2 selection boxes next to the input area, select "16-bit integer" and "HEX".

5 Entering User Messages

As shown in the illustration below, the dialog box for character string inputs is opened by double-clicking on GX Developer's character string display area or the data register display area.

When entering Japanese scripts (Chinese characters, etc.), data input automatically occurs in the lower order → higher order sequence, and the input can therefore be used as it is at the display module's user message display.

The GX Developer screen's character string shown below is for "program example 1".

→ Refer to Subsection 19.23.4 for "program example 1" details.

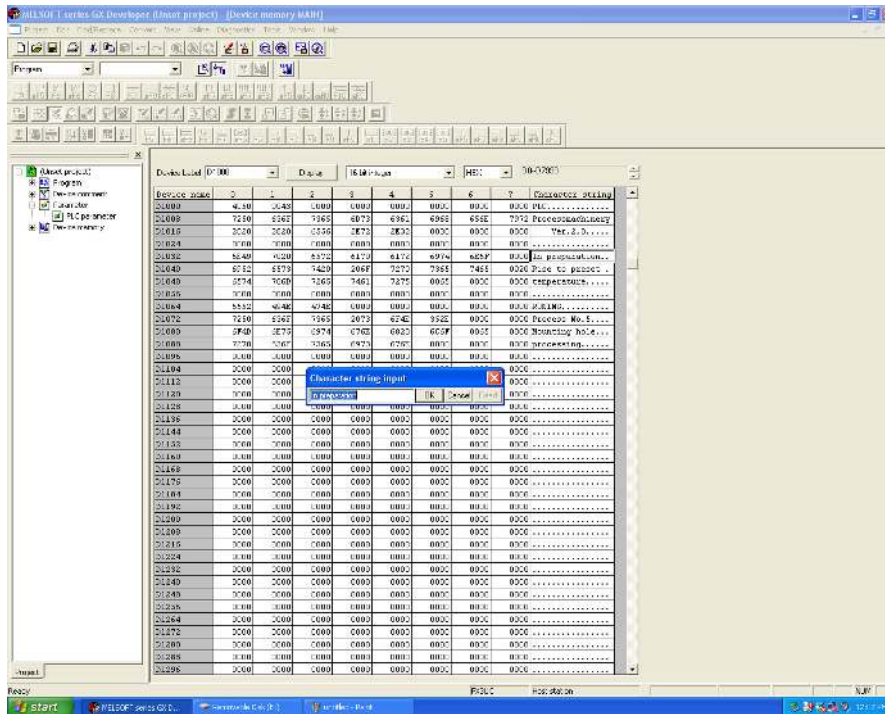

GX Developer character arrangement precautions:

A single line is comprised of 8 data registers.

To prevent garbled characters when a 2-byte character (shift JIS code) arrangement extends into the next line, the system replaces those characters with 2 spaces.

([Ex] spaces display at the end of the 1st line and at the beginning of the 2nd line.)

The condition of the display module line must therefore be considered when entering the characters.

Moreover, the 1st character device should be specified for displaying a 1-line character input.

11	High-Speed Counters
12	Output Wiring
13	Wiring for Various Uses
14	Test Run, Maintenance, Troubleshooting
15	Input/Output Powered Extension Units
16	Input/Output Extension Blocks
17	Extension Power Supply Unit
18	Other Extension Units and Options
19	Display Module
20	Terminal Block

19.24 Operation Error Messages & Corrective Actions

The following is a list of error messages which the system displays after an operation is performed.

Relevant Menu Screen	English	Japanese	Corrective Action
<ul style="list-style-type: none"> All menus 	Entry Code error	操作できません キーワードによって保護されています	Cancel the entry code, then attempt the operation again.
<ul style="list-style-type: none"> Entry code 	The Entry Code is not set	キーワードが設定されていません	No entry code has been registered. Entry codes cannot be registered from the display module. A programming tool such as GX Developer, etc., is required to register entry codes.
	Incorrect Entry Code!	キーワード不一致	The entered entry code does not match the registered entry code. Verify the registered entry code, then enter the correct entry code.
<ul style="list-style-type: none"> Monitor/test (user-registered devices) 	The wrong device is registered	存在しないデバイスが登録されています	A device has been specified that does not exist among the system information (system signal 1) "user-registered device" monitor devices. Check the program.
<ul style="list-style-type: none"> Monitor/test (setting change) Memory cassette transfer 	PLC is running	RUN中です!	Stop the PLC, then attempt the operation again.
	Memory Cassette is write-protected	書き込み禁止です	Turn the memory cassette's write-protected status to OFF, then attempt the operation again.
	Write error	書き込みエラー	Writing failed. Verify that the memory cassette is properly installed.
	Read error	読み込みエラー	Reading failed. Verify that the memory cassette is properly installed.
<ul style="list-style-type: none"> PLC Status Monitor/test (setting change) Memory cassette transfer 	Fatal error occurred	フェータルエラー発生中	→ Refer to Subsection 19.24.1 for details.
<ul style="list-style-type: none"> Memory cassette transfer 	Memory Cassette is misconnected	メモリーカセットが装着されていません	Turn the PLC power OFF, install the memory cassette, then attempt the operation again.
	The Entry Code is set in the Internal Memory	内蔵メモリにキーワードが設定されています	Remove the memory cassette, restart the unit (power OFF→ON), then use the programming tool to cancel the entry code in the internal RAM.
<ul style="list-style-type: none"> Memory cassette transfer (consistency check) 	Programs match	プログラムが一致しています	The memory cassette program matches the RAM program.
	Programs don't match	プログラム不一致	The memory cassette program does not match the RAM program.
<ul style="list-style-type: none"> Memory cassette transfer (reading/writing) 	Transfer completed	転送成功しました	Transfer successful.
	Transfer failed	転送失敗しました	Check if the memory cassette is properly installed.
	The Program size exceeds target memory capacity	転送先の容量を超えています	The transfer origin memory capacity exceeds the transfer destination memory capacity. Check the memory capacity.

19.24.1 When a "Fatal error occurred" message appears

Operation is possible with the "Level C" or "Level B" entry code function restrictions. However, the system is probably in one of the statuses described below. Check these statuses in the order shown below, and take the appropriate corrective action.

1. **Perform an error check at the display module, and if an error is active, take the appropriate corrective action.**

→ Refer to Section 19.9 for the error check procedure.

If a program error is active:

The fatal error was probably activated due to a program error. Use the programming tool to correct the program.

→ Refer to Section 14.6 for error codes and corrective actions.

→ Refer to Subsection 14.5.3 for watchdog timer error corrective actions.

If no program error is active:

There may be a problem with the PLC's memory content. Perform the following procedure.

- 1) Use the programming tool to perform a program memory all-clear.
- 2) Rewrite the program.
- 3) Stop the PLC, turn the power ON, display the "PLC Status (1/3)" screen and check to refer to if the "Fatal error occurred" message appears.
 - If the "Fatal error occurred" message appears, perform the corrective action described at item "2" below.
 - If the "Fatal error occurred" message does not appear, set the PLC to a RUN state, then check again if the message appears.
If the message appears, a watchdog timer error has probably occurred. In this case, the program should be re-examined.

→ Refer to Subsection 14.5.3 for watchdog timer error corrective actions.

2. **If the "Fatal error occurred" message still appears after performing the corrective actions described in item 1 above, perform the following procedure to check for symptom changes.**

Turn the power OFF and disconnect all extension devices.
(extension connectors, extension cables, and expansion board connectors)

Turn the power ON again at the main unit, display the "PLC Status(1/3)" screen again, and check if the "Fatal error occurred" message appears.

- 1) If the "Fatal error occurred" message appears:
The main unit hardware may have failed. Contact your local Mitsubishi Electric representative.
- 2) If the "Fatal error occurred" message does not appear:
Turn the power OFF, connect the extension devices, then operate the system again to check for errors. If the problem persists, there may be main unit or extension device hardware failure. Contact your local Mitsubishi Electric representative.

11	High-Speed Counters
12	Output Wiring
13	Wiring for Various Uses
14	Test Run, Maintenance, Troubleshooting
15	Input/Output Powered Extension Units
16	Input/Output Extension Blocks
17	Extension Power Supply Unit
18	Other Extension Units and Options
19	Display Module
20	Terminal Block

19.25 Menu Display Characters - Japanese & English Display Character Correspondence Table

Menu Screen	English	Japanese	Menu Screen	English	Japanese	
Menu	Monitor/Test	モニター/テスト	PLC Status	PLC Status(1/3) Ver.--	PC情報(1/3) Ver. --	
	ErrorCheck	エラーチェック		Fatal error occurred	フェー列エラー 発生中	
	LANGUAGE	LANGUAGE		The Entry Code is not set	キーワードは設定 されていません	
	Contrast	コントラスト		PLC operation is limited	操作が制限 されています	
	ClockMenu	時刻設定		All operation is unrestricted	すべての操作が 可能です	
	EntryCode	キーワード		PLC operation is unavailable	操作が禁止 されています	
	ClearAllDev	デバイスオールクリア		PLC Status(2/3)	PC情報(2/3)	
	PLC Status	PCステータス		Internal Memory	内蔵RAM	
ScanTime	スキャンタイム表示	Memory Cassette		メモリカセット		
Cassette	メモリカセット転送	Protection --		プログラムスイッチ --		
ErrorCheck	ErrorCheck	エラーチェック	Capacity --K	メモリ容量 -- K		
	No errors	エラー無し	PLC Status(3/3)	PC情報(3/3)		
	Error code	エラーコード	Battery --V	バッテリー電圧 --V		
LANGUAGE (Menu display language setting)	LANGUAGE 日本語	LANGUAGE 日本語	Comments	登録コメント数		
	English	English	ScanTime (Scan time display)	スキャンタイム 現在値: --ms 最大値: --ms 最小値: --ms		
Contrast	Contrast	コントラスト	Cassette (Memory cassette transfer)	Memory Cassette Cassette←RAM Cassette→RAM Cassette:RAM	メモリカセット転送 メモリカセット←RAM メモリカセット→RAM メモリカセット:RAM	
ClockMenu (Current time setting)	Current time	現在時刻		Cassette ←RAM	Cassette←RAM (Write) Please wait...	メモリカセット←RAM (書き込み) 実行中...
	Clock setting	時刻変更		Cassette →RAM	Cassette→RAM (Read) Please wait...	メモリカセット→RAM (読み出し) 実行中...
	Clock setting	時刻変更		Cassette →RAM Cassette ←RAM	Transfer completed	転送成功しました
Current time is set	現在時刻を 設定しました	現在時刻を 設定しました	Cassette ←RAM	Transfer failed	転送失敗しました	
EntryCode	Please, input Entry Code	キーワードを 入力してください	Cassette:RAM	Cassette:RAM (Verify) Please wait...	メモリカセット:RAM (照合) 実行中...	
	*****	*****		Programs match	プログラムが 一致しています	
	Make Entry Code valid? OK→Execute ESC→Cancel	キーワードを 有効にしますか OK→実行 ESC→キャンセル		Programs don't match	プログラム不一致	
	All operation is possible	操作が 可能になりました				
ClearAllDev (Device all-clear)	Incorrect Entry Code	キーワード不一致				
	Clear all devices OK→Execute ESC→Cancel	デバイスオールクリア OK→実行 ESC→キャンセル				
	All device were cleared	デバイスオールクリア しました				

20. FX-16/32E*-*-TB (Terminal Block)

DESIGN PRECAUTIONS



- Make sure to have the following safety circuits outside of the PLC to ensure safe system operation even during external power supply problems or PLC failure. Otherwise, malfunctions may cause serious accidents.
 - 1) Most importantly, have the following: an emergency stop circuit, a protection circuit, an interlock circuit for opposite movements (such as normal vs. reverse rotation), and an interlock circuit (to prevent damage to the equipment at the upper and lower positioning limits).
 - 2) Note that when the PLC CPU detects an error, such as a watchdog timer error, during self-diagnosis, all outputs are turned off. Also, when an error that cannot be detected by the PLC CPU occurs in an input/output control block, output control may be disabled. External circuits and mechanisms should be designed to ensure safe machinery operation in such a case.
 - 3) Note that the output current of the 24V DC service power supply varies depending on the model and the absence/presence of extension blocks. If an overload occurs, the voltage automatically drops, inputs in the PLC are disabled, and all outputs are turned off. External circuits and mechanisms should be designed to ensure safe machinery operation in such a case.
 - 4) Note that when an error occurs in a relay, triac or transistor output device, the output could be held either on or off. For output signals that may lead to serious accidents, external circuits and mechanisms should be designed to ensure safe machinery operation in such a case.

DESIGN PRECAUTIONS



- Do not bundle the control line together with or lay it close to the main circuit or power line. As a guideline, lay the control line at least 100mm (3.94") or more away from the main circuit or power line. Noise may cause malfunctions.
- Install module so that excessive force will not be applied to peripheral device connectors. Failure to do so may result in wire damage/breakage or PLC failure.

INSTALLATION PRECAUTIONS



- Make sure to cut off all phases of the power supply externally before attempting installation or wiring work. Failure to do so may cause electric shock or damage to the product.

11

High-Speed
Counters

12

Output Wiring

13

Wiring for
Various Uses

14

Test Run,
Maintenance,
Troubleshooting

15

Input/Output
Powered
Extension Units

16

Input/Output
Extension
Blocks

17

Extension
Power Supply
Unit

18

Other Extension
Units and
Options

19

Display Module

20

Terminal Block

INSTALLATION PRECAUTIONS



- Use the product within the generic environment specifications described in section 4.1 of this manual. Never use the product in areas with excessive dust, oily smoke, conductive dusts, corrosive gas (salt air, Cl₂, H₂S, SO₂ or NO₂), flammable gas, vibration or impacts, or expose it to high temperature, condensation, or rain and wind. If the product is used in such conditions, electric shock, fire, malfunctions, deterioration or damage may occur.
- Do not touch the conductive parts of the product directly. Doing so may cause device failures or malfunctions.
- Install the product securely using a DIN rail or mounting screws.

FX2N-10GM, FX2N-20GM, and terminal block	DIN rail only
Main unit, FX2N Series I/O extension unit/block, and FX0N/FX2N/FX3U Series special extension block/special adapter	DIN rail or direct mounting

- Install the product on a flat surface. If the mounting surface is rough, undue force will be applied to the PC board, thereby causing nonconformities.
- When drilling screw holes or wiring, make sure that cutting and wiring debris do not enter the ventilation slits. Failure to do so may cause fire, equipment failures or malfunctions.
- Be sure to remove the dust proof sheet from the PLC's ventilation port when installation work is completed. Failure to do so may cause fire, equipment failures or malfunctions.
- Connect the extension cables, peripheral device cables, input/output cables and battery connecting cable securely to their designated connectors. Loose connections may cause malfunctions.
- Turn off the power to the PLC before attaching or detaching the following devices. Failure to do so may cause device failures or malfunctions.
 - Peripheral devices, display modules, expansion boards and special adapters
 - Extension units/blocks and FX Series terminal blocks
 - Battery and memory cassette

WIRING PRECAUTIONS



- Make sure to cut off all phases of the power supply externally before attempting installation or wiring work. Failure to do so may cause electric shock or damage to the product.
- Make sure to attach the terminal cover, offered as an accessory, before turning on the power or initiating operation after installation or wiring work. Failure to do so may cause electric shock.

WIRING PRECAUTIONS



- Connect the AC power supply wiring to the dedicated terminals described in this manual. If an AC power supply is connected to a DC input/output terminal or DC power supply terminal, the PLC will burn out.
- Connect the DC power supply wiring to the dedicated terminals described in this manual. If an AC power supply is connected to a DC input/output terminal or DC power supply terminal, the PLC will burn out.
- Do not wire vacant terminals externally. Doing so may damage the product.
- When drilling screw holes or wiring, make sure that cutting and wiring debris do not enter the ventilation slits. Failure to do so may cause fire, equipment failures or malfunctions.
- Make sure to properly wire to the FX Series terminal blocks in accordance with the following precautions. Failure to do so may cause electric shock, equipment failures, a short-circuit, wire breakage, malfunctions, or damage to the product.
 - The disposal size of the cable end should follow the dimensions described in the manual.
 - Tightening torque should follow the specifications in the manual.

20.1 Overview

A terminal block is used to convert connector type input/output terminals into a terminal block. Moreover, dedicated input and output terminal blocks (built-in element types) can be used to receive AC input signals for conversion to relay / transistor / triac output types.

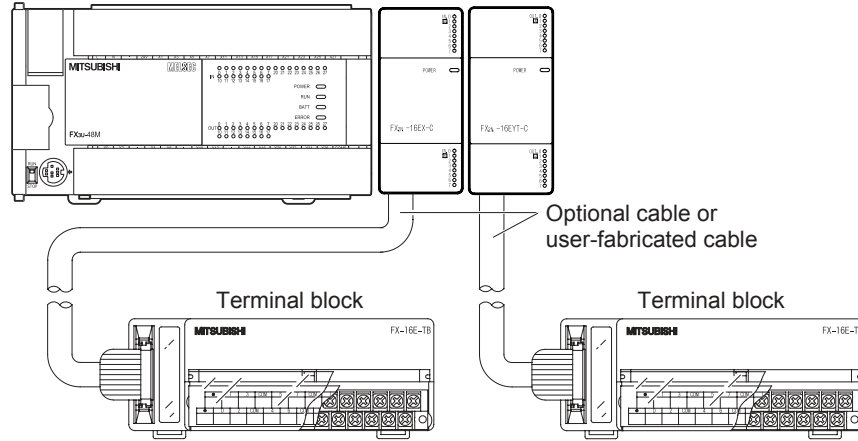

11	High-Speed Counters
12	Output Wiring
13	Wiring for Various Uses
14	Test Run, Maintenance, Troubleshooting
15	Input/Output Powered Extension Units
16	Input/Output Extension Blocks
17	Extension Power Supply Unit
18	Other Extension Units and Options
19	Display Module
20	Terminal Block

20.1.1 Product configuration

The connection destinations shown below are products which can be connected by "connector ↔ connector" cables. An individual-wire type can also be used for wiring to the terminal blocks of PLC-side input/output products.

Model Name	Number of Input Points	Number of Output Points	Function	Connection Destination	Drive Power Supply
FX-16E-TB	16 input points or 16 output points		Connects directly to PLC input/output terminals.	FX2N-16EX-C (sink input) FX2N-16EYT-C (sink output)	*1
FX-32E-TB	32 input points, 32 output points, or 16 input & 16 output points				
FX-16EX-A1-TB*2	16	–	100V AC input type	FX2N-16EX-C (sink input)	*4
FX-16EYR-TB*3		16	Relay output type	FX2N-16EYT-C (sink output)	24V DC 80 mA
FX-16EYS-TB*3	–	16	Triac output type	FX2N-16EYT-C (sink output)	24V DC 112 mA
FX-16EYT-TB*3	–	16	Transistor output (sink) type	FX2N-16EYT-C (sink output)	24V DC 112 mA
FX-16EYT-H-TB*3	–	16	Transistor output (sink) type	FX2N-16EYT-C (sink output)	24V DC 112 mA

- *1. A power supply for the input circuit is required when connected to the FX2N-16EX-C.
The current consumption is shown in the table below.

	Power Supply Voltage	Current Consumption
FX2N-16EX-C	24V DC	112 mA

- *2. The applications shown below are not supported.

Unsupported Applications	
High-speed processing	High-speed counter, input interruption, pulse catch, speed detection (SPD) instruction
Time division input	Input matrix (MTR) instruction, hexadecimal input (HKY) instruction, digital switch (DSW) instruction, arrow switch (ARWS) instruction
Other	Refresh and filter adjust (REFF) instruction, ten key input (TKY) instruction, absolute current value read (ABS) instruction

- *3. The applications shown below are not supported.

Unsupported Applications	
Pulse output	Pulse Y output (PLSY) instruction, acceleration/deceleration setup (PLSR) instruction, pulse width modulation (PWM) instruction, DOG search zero return (DSZR) instruction, interruption positioning (DVIT) instruction, batch data positioning mode (TBL) instruction, absolute current value read (ABS) instruction, zero return (ZRN) instruction, variable speed pulse output (PLSV) instruction, drive to increment (DRVI) instruction, drive to absolute (DRVA) instruction
Time division input	Input matrix (MTR) instruction, hexadecimal input (HKY) instruction, digital switch (DSW) instruction, arrow switch (ARWS) instruction
Time division output	Seven segment with latch (SEGL) instruction, print (ASCII Code) (PR) instruction

- *4. A power supply for the input circuit is required when connected to the FX2N-16EX-C.
The current consumption is shown in the table below.

	Power Supply Voltage	Current Consumption
FX2N-16EX-C	24V DC	160 mA

20.2 External Dimensions & Component Names

FX-16E-TB

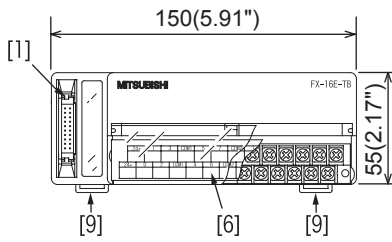

FX-32E-TB

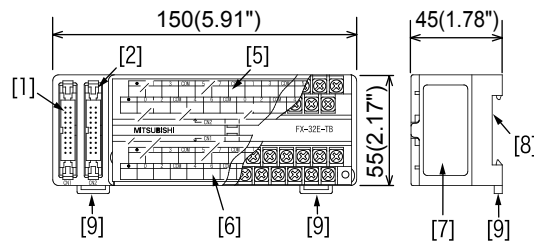

FX-16EX-A1-TB

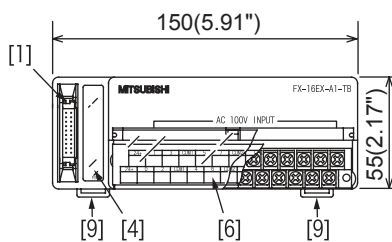

FX-16EYR-TB
FX-16EYS-TB
FX-16EYT-TB, FX-16EYT-H-TB

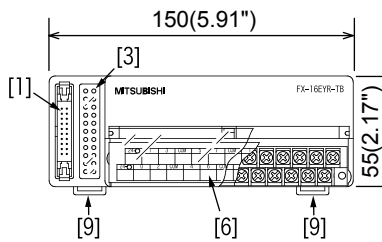

Units: mm (inches)
Accessories: Input/output No. labels, terminal block arrangement cards

No.	Name	Remarks
[1]	CN1 connector	-
[2]	CN2 connector	Present at FX-32E-TB.
[3]	Operation indicator LED	Present at FX-16EYR-TB, FX-16EYS-TB, FX-16EYT-TB, FX-16EYT-H-TB.
[4]	POWER LED	Present at FX-16EX-A1-TB.
[5]	CN2 terminal block (M3.5 screws)	Present at FX-32E-TB.
[6]	CN1 terminal block (M3.5 screws)	-
[7]	Nameplate	-
[8]	DIN rail mounting groove (DIN rail width: 35mm(1.38"))	-
[9]	DIN rail mounting hook	-

11 High-Speed Counters

12 Output Wiring

13 Wiring for Various Uses

14 Test Run, Maintenance, Troubleshooting

15 Input/Output Powered Extension Units

16 Input/Output Extension Blocks

17 Extension Power Supply Unit

18 Other Extension Units and Options

19 Display Module

20 Terminal Block

20.3 Terminal Arrangement

1. FX-16E-TB

When connected to the FX2N-16EYT-C

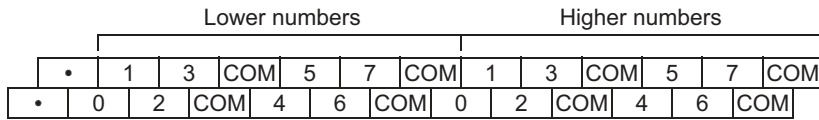
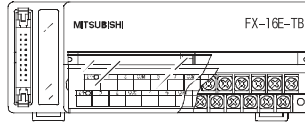

When connected to the FX2N-16EX-C

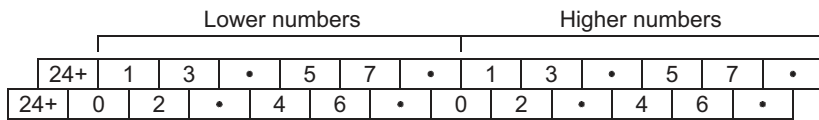
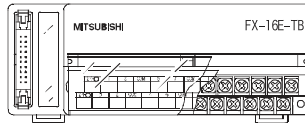

2. FX-32E-TB

When connected to the FX2N-16EYT-C

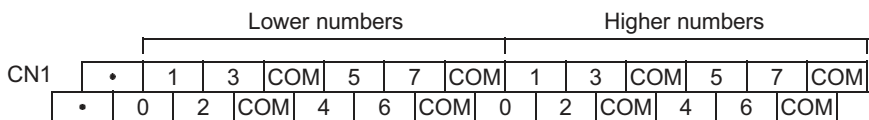
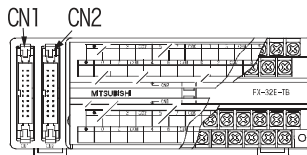
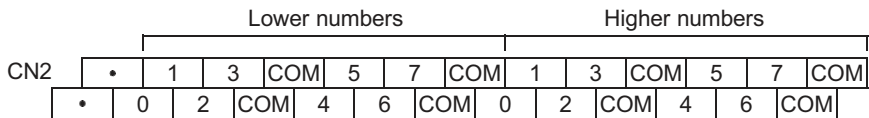

When connected to the FX2N-16EX-C

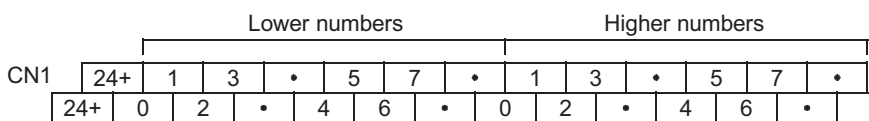
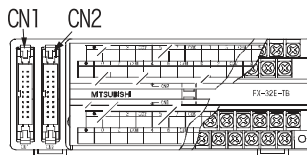
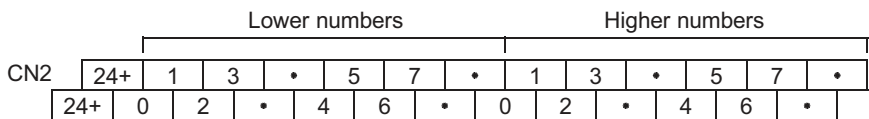

3. FX-16EX-A1-TB

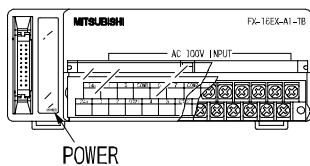

Lower numbers							Higher numbers						
24+	1	3	COM1	5	7	COM2	1	3	COM3	5	7	COM4	
24-	0	2	COM1	4	6	COM2	0	2	COM3	4	6	COM4	

4. FX-16EYR-TB, FX-16EYS-TB, FX-16EYT-TB, FX-16EYT-H-TB

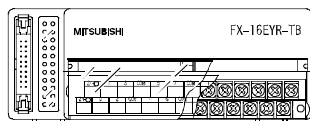

Lower numbers							Higher numbers						
24+	1	3	COM1	5	7	COM2	1	3	COM3	5	7	COM4	
24-	0	2	COM1	4	6	COM2	0	2	COM3	4	6	COM4	

11	High-Speed Counters
12	Output Wiring
13	Wiring for Various Uses
14	Test Run, Maintenance, Troubleshooting
15	Input/Output Powered Extension Units
16	Input/Output Extension Blocks
17	Extension Power Supply Unit
18	Other Extension Units and Options
19	Display Module
20	Terminal Block

20.4 Installation Work

→ Refer to Section 8.2 for installation location.

20.4.1 Mounting

- 1** Turn OFF all power supplies connected to the PLC, input/output devices, and terminal blocks.
- 2** Align the top side of the "DIN rail mounting groove" (refer to Fig.1 at right) with the DIN rail.
- 3** Press the product onto the DIN rail (refer to Fig.2 at right).

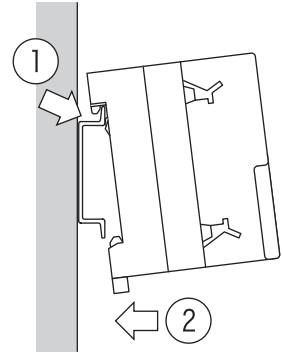

20.4.2 Removal

- 1** Turn the power supply OFF.
- 2** Disconnect the wiring and input/output cables.
- 3** Place a flathead screwdriver against the DIN rail mounting hook in the posture shown (refer to Fig.1 at right)
- 4** Move the flathead screwdriver in direction shown at right (refer to Fig.2) to detach the DIN rail mounting hook from the DIN rail.
- 5** Remove the product from the DIN rail.

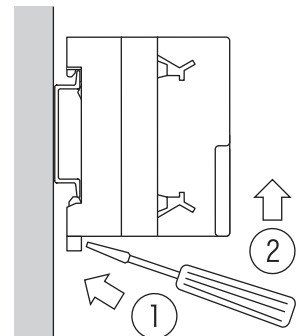

20.4.3 Input/output cable connection

The terminal block's CN1 and CN2 connectors comply with the MIL-83503 standard.

→ Refer to Subsection 9.2.2 for input/output cable information.

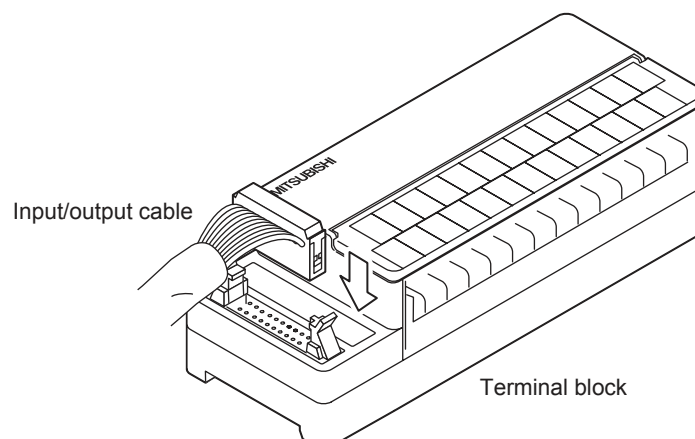

20.4.4 Connection to terminal block

1. The product terminal screws are as shown in the table below.

Model Name	Terminal Screw Size
<ul style="list-style-type: none"> FX-16E-TB, FX-32E-TB FX-16EX-A1-TB FX-16EYR-TB FX-16EYS-TB FX-16EYT-TB, FX-16EYT-H-TB 	M3.5

2. Crimp terminal sizes vary according to the wiring method.

Use the sizes shown below.

- When 1 wire is connected to 1 terminal:
Use a crimp terminal of the size shown below, and install it as shown in the lower right figure.

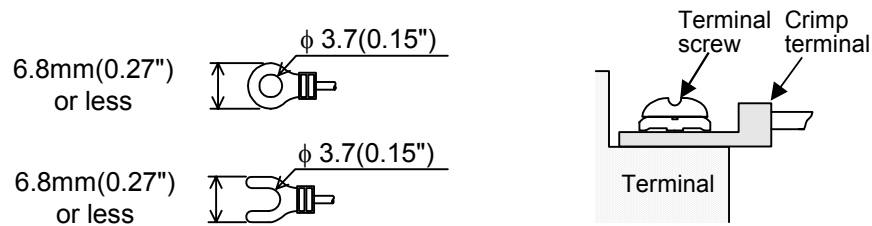

- When 2 wires are connected to 1 terminal:
Use a crimp terminal of the size shown below, and install it as shown in the lower right figure.

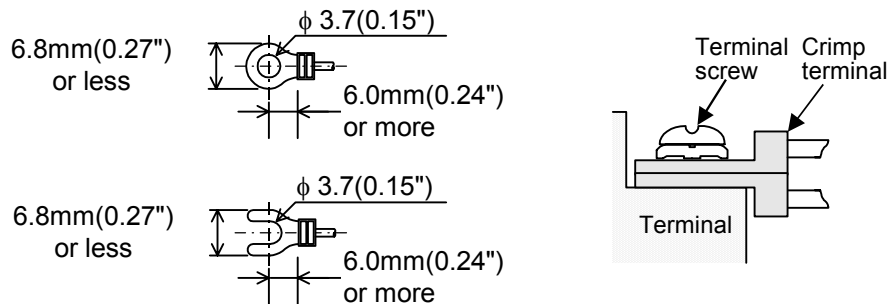

20.5 FX-16E-TB, FX-32E-TB

The FX-16E-TB and FX-32E-TB items must be connected using an FX2N series input/output connector type extension block.

	Input Connector	Output Connector
Connectable models	FX2N-16EX-C (sink input)	FX2N-16EYT-C (sink output)

20.5.1 Internal circuit

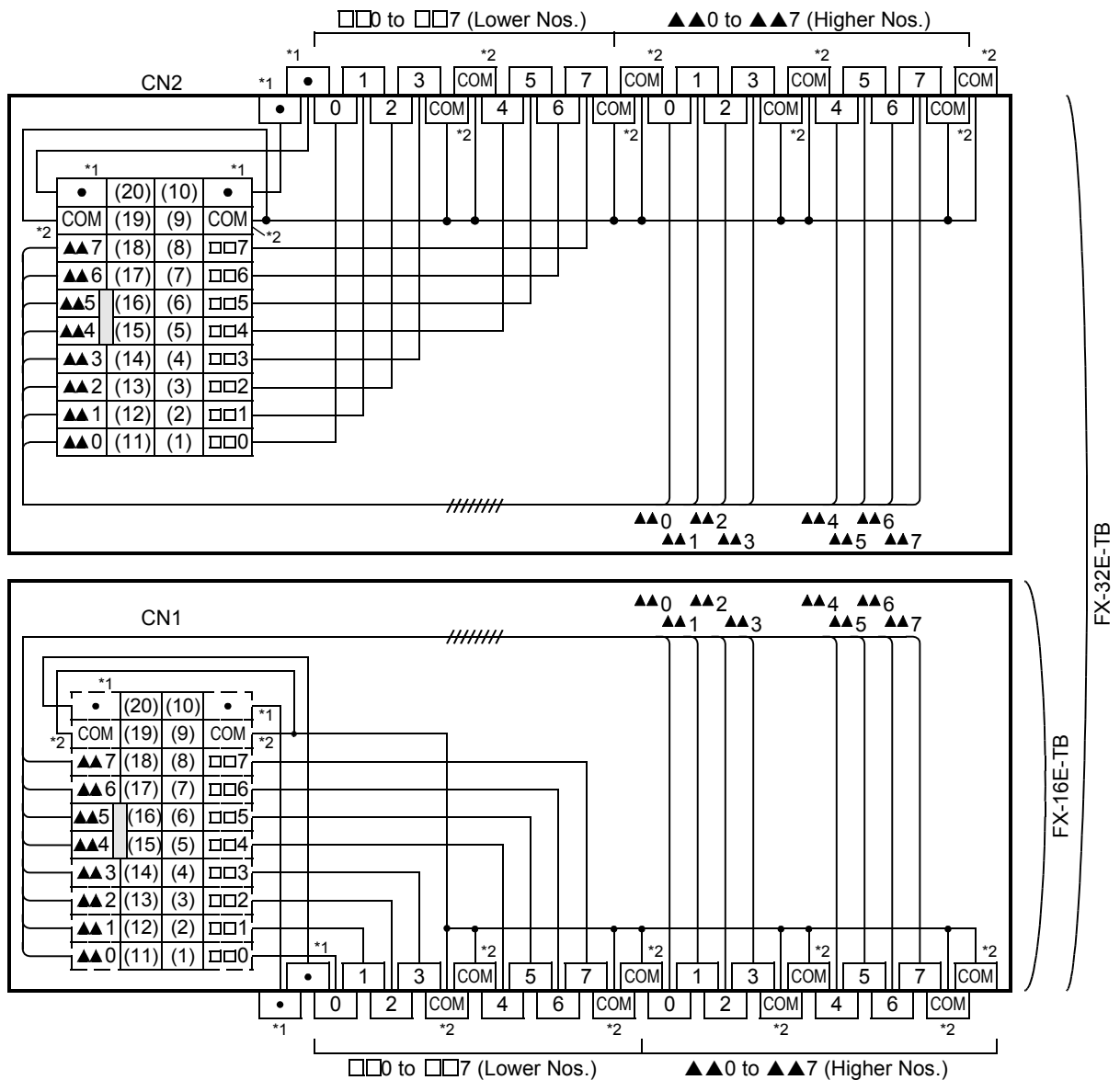

*1 "24+" when connected to FX2N-16EX-C.
 *2 "●" when connected to FX2N-16EX-C.

20.5.2 Example of input external wiring

WIRING PRECAUTIONS



- Do not wire vacant terminals externally.
Doing so may damage the product.

1. When connected to an FX2N-16EX-C (sink input) input extension block:

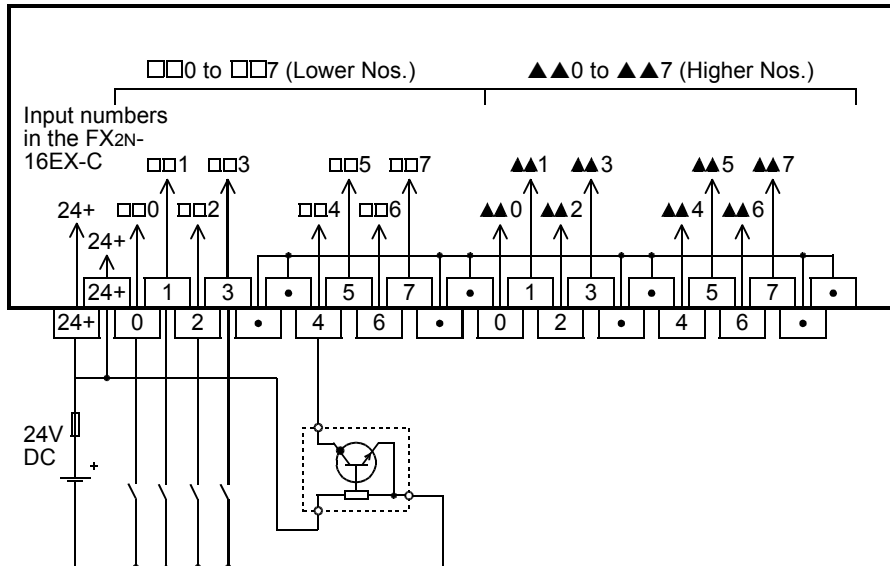

20.5.3 Output external wiring

WIRING PRECAUTIONS



- Do not wire vacant terminals externally.
Doing so may damage the product.

1. When connected to an FX2N-16EYT-C (sink output) output extension block:

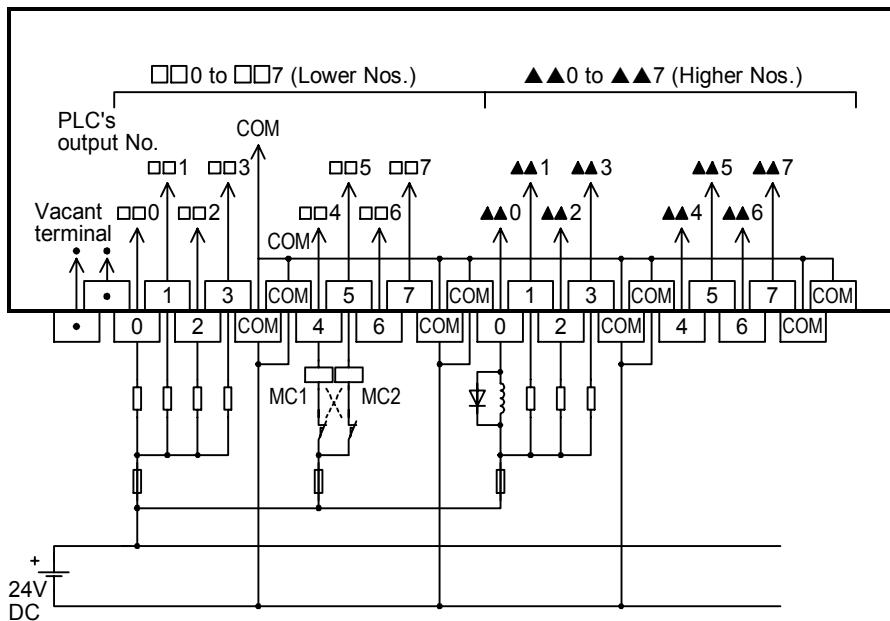

11	High-Speed Counters
12	Output Wiring
13	Wiring for Various Uses
14	Test Run, Maintenance, Troubleshooting
15	Input/Output Powered Extension Units
16	Input/Output Extension Blocks
17	Extension Power Supply Unit
18	Other Extension Units and Options
19	Display Module
20	Terminal Block

20.6 FX-16EX-A1-TB

The FX-16EX-A1-TB is used by connecting it to the FX2N series input extension block (24V DC).

Input Connector	
Connectable models	FX2N-16EX-C (sink input)

The applications shown below are not supported.

Unsupported Applications	
High-speed processing	High-speed counter, input interruption, pulse catch, speed detection (SPD) instruction
Time division input	Input matrix (MTR) instruction, hexadecimal input (HKY) instruction, digital switch (DSW) instruction, arrow switch (ARWS) instruction
Other	Refresh and filter adjust (REFF) instruction, ten key input (TKY) instruction, absolute current value read (ABS) instruction

20.6.1 Specifications

Item	AC Input Type
Input/output circuitry	
Input signal voltage	100 to 120V AC +10%, -15% 50 / 60 Hz
Input signal current	4.7 mA / 100V AC 50 Hz 6.2 mA / 110V AC 60 Hz
Input impedance	Approx. 21 kΩ / 50 Hz Approx. 18 kΩ / 60 Hz
Input sensitivity	ON 3.8 mA / 80V AC or more OFF 1.7 mA / 30V AC or more
Response time ^{*1}	25 to 30 ms
Input signal format	Voltage contact
Circuit isolation	Photocoupler isolation
Input operation display	No input LEDs (equipped with 24V power supply LED indicator)
Power consumption	1.2 W (48 mA 24V DC) ^{*2}

*1. This response time does not include the response delay at the PLC.

*2. 3.9W (160mA, 24V DC) is required when connected to the FX2N-16EX-C.

20.6.2 Internal circuit

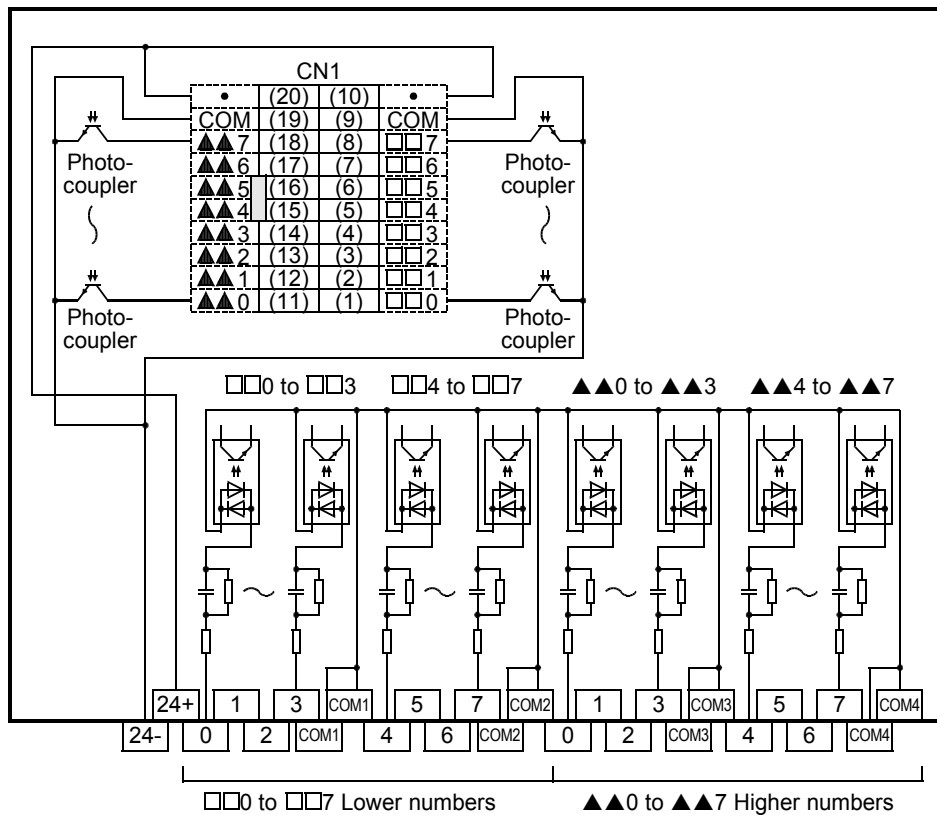

20.6.3 Example of input external wiring

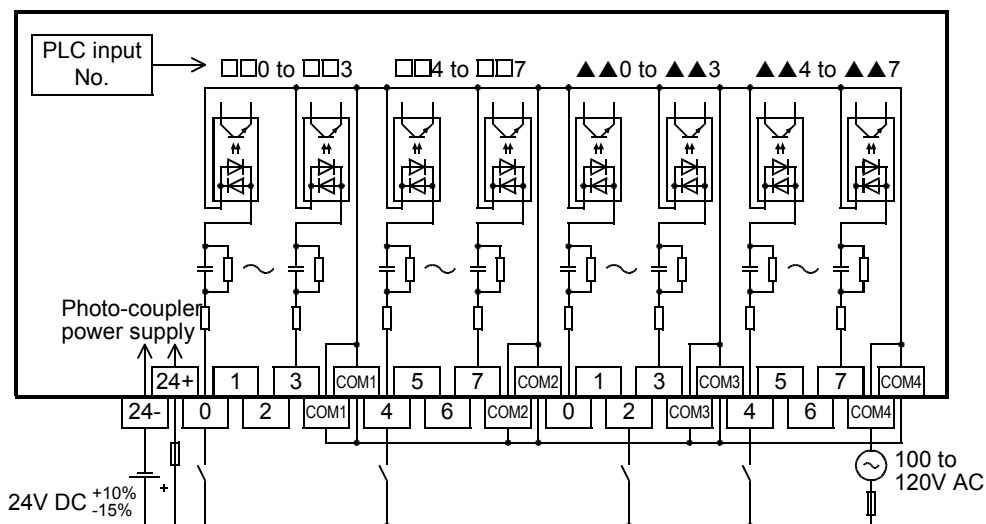

11	High-Speed Counters
12	Output Wiring
13	Wiring for Various Uses
14	Test Run, Maintenance, Troubleshooting
15	Input/Output Powered Extension Units
16	Input/Output Extension Blocks
17	Extension Power Supply Unit
18	Other Extension Units and Options
19	Display Module
20	Terminal Block

20.7 FX-16EYR-TB

The FX-16EYR-TB is available by connecting it to a FX2N series output extension block (transistor).

Output Connector	
Connectable models	FX2N-16EYT-C (sink output)

The applications shown below are not supported.

Unsupported Applications	
Pulse outputs	Pulse Y output (PLSY) instruction, acceleration/deceleration setup (PLSR) instruction, pulse width modulation (PWM) instruction, DOG search zero return (DSZR) instruction, interruption positioning (DVIT) instruction, batch data positioning mode (TBL) instruction, absolute current value read (ABS) instruction, zero return (ZRN) instruction, variable speed pulse output (PLSV) instruction, drive to increment (DRVl) instruction, drive to absolute (DRVA) instruction
Time division input	Input matrix (MTR) instruction, hexadecimal input (HKY) instruction, digital switch (DSW) instruction, arrow switch (ARWS) instruction
Time division output	Seven segment with latch (SEGL) instruction, print (ASCII Code) (PR) instruction

20.7.1 Specifications

Item	Relay output
Input/output circuitry	
Load voltage	250V AC or less, 30V DC or less
Max. load	Resistance load
	Inductive load
Min. load	5V DC, 2mA Reference value
Open-circuit leakage current	-
Response time *1	Approx. 10 ms
Circuit isolation	Mechanical isolation
Operation indicators	LED is lit when relay coil power is supplied
Power consumption	1.92 W (80 mA 24V DC)

*1. This response time does not include the response delay of the PLC.

20.7.2 Internal circuit

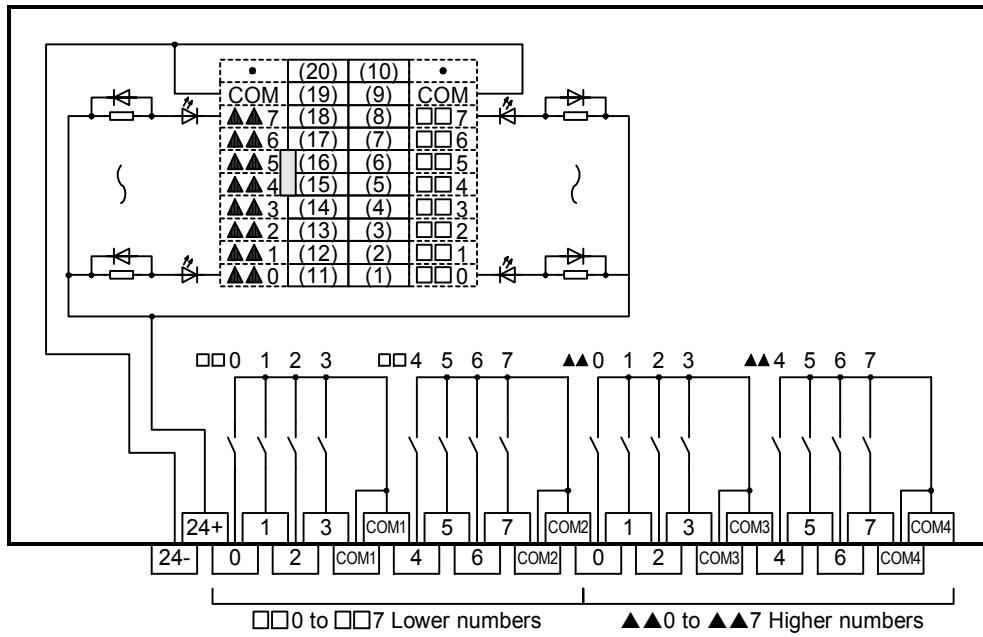

20.7.3 Example of output external wiring

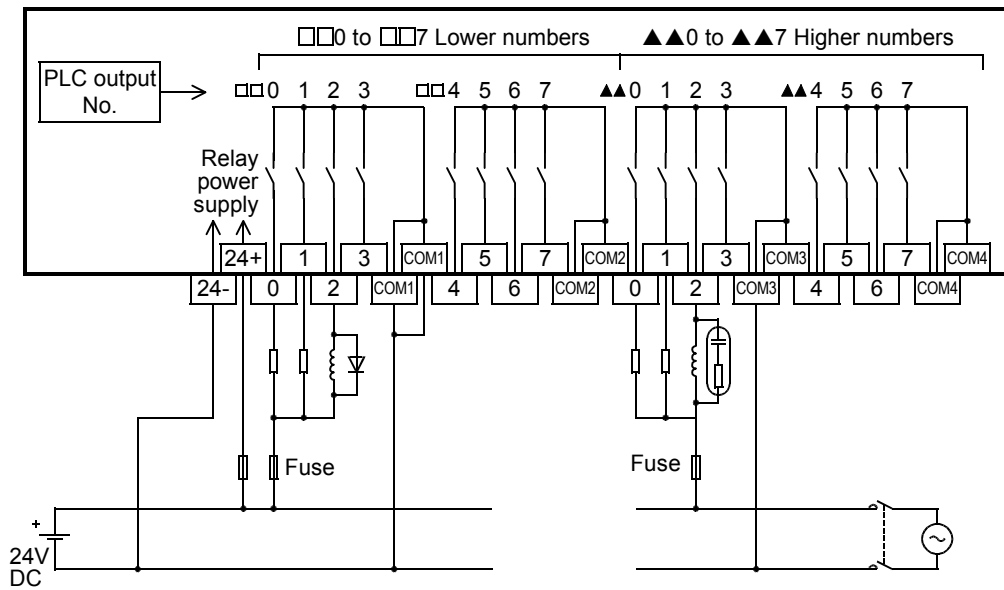

11	High-Speed Counters
12	Output Wiring
13	Wiring for Various Uses
14	Test Run, Maintenance, Troubleshooting
15	Input/Output Powered Extension Units
16	Input/Output Extension Blocks
17	Extension Power Supply Unit
18	Other Extension Units and Options
19	Display Module
20	Terminal Block

20.7.4 External wiring precautions

1. Protection circuit for load short-circuits

A short-circuit at a load connected to an output terminal could cause burnout at the output element or the PCB. To prevent this, a protection fuse should be inserted at the output.

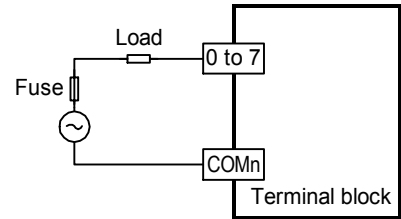

2. Contact protection circuit for inductive loads

An internal protection circuit for the relays is not provided for the relay output circuit in the terminal block. It is recommended to use inductive loads with built-in protection circuits. When using loads without built-in protection circuits, insert an external contact protection circuit, etc. to reduce noise and extend the product life.

1) DC circuit

Connect a diode (for commutation) parallel to the load.

The diode (for commutation) must comply with the following specifications.

Item	Guide
Reverse voltage	5 to 10 times the load voltage
Forward current	Load current or more

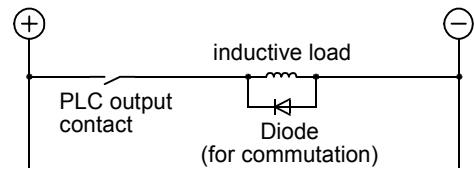

2) AC circuit

Connect the surge absorber (combined CR components such as a surge killer and spark killer, etc.), parallel to the load.

Select the rated voltage of a surge absorber that is suitable for the load being used. Refer to the table below for other specifications.

Item	Guide
Static electricity capacity	Approx. 0.1μF
Resistance value	Approx. 100 to 200Ω

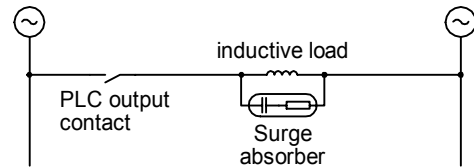

Reference

Manufacturer	Model name
Okaya Electric Industries Co., Ltd.	CR-10201

Manufacturer	Model name
Rubycon Corporation	250MCRA104100M B0325

3. Interlock

For loads such as forward/reverse contactors, etc., where a hazardous condition could result if switched ON simultaneously, an external interlock should be provided for interlocking the PLC's internal programs as shown to the right.

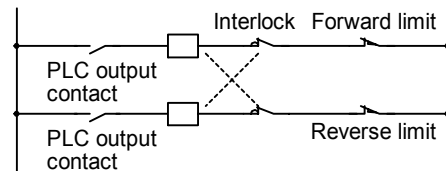

4. In-phase

PLC output contacts (*) should be used in an "in-phase" manner.

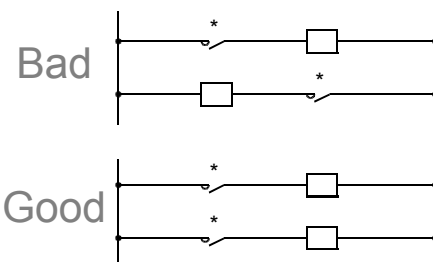

20.7.5 Product life of relay output contacts

The product life of relay contacts varies considerably depending on the load type used. Take care that loads generating reverse electromotive force or rush current may cause poor contact or deposition of contacts which may lead to considerable reduction of the contact product life.

1. Inductive load

Inductive loads generate large reverse electromotive force between contacts at shutdown, which may cause arcing. At a fixed current consumption, as the power factor (phase between current and voltage) gets smaller, the arc energy gets larger.

The standard life of contacts used for Inductive loads, such as contactors and solenoid valves, is 500,000 operations at 35 VA.

The following table shows the approximate life of a relay based on the results of an operation life test.

Test conditions: 1 sec. ON / 1 sec. OFF

Load Capacity		Contact Life
35VA	0.35 A / 100V AC	3,000,000 times
	0.17 A / 200V AC	
80VA	0.8 A / 100V AC	1,000,000 times
	0.4 A / 200V AC	
120VA	1.2 A / 100V AC	200,000 times
	0.6 A / 200V AC	

The product life of relay contacts becomes considerably shorter than the above conditions when the rush overcurrent is shut down.

→ **For precautions on inductive loads, refer to Subsection 20.7.4 2**

Some types of inductive loads generate rush current 5 to 15 times the stationary current at activation. Make sure that the rush current does not exceed the current corresponding to the maximum specified resistance load.

2. Lamp load

Lamp loads generally generate rush current 10 to 15 times the stationary current. Make sure that the rush current does not exceed the current corresponding to the maximum specified resistance load.

3. Capacitive load

Capacitive loads can generate rush current 20 to 40 times the stationary current. Make sure that the rush current does not exceed the current corresponding to the maximum specified resistance load. Capacitive loads such as capacitors may be present in electronic circuit loads including inverters.

→ **For the maximum specified resistance load, refer to Subsection 20.7.1**

11	High-Speed Counters
12	Output Wiring
13	Wiring for Various Uses
14	Test Run, Maintenance, Troubleshooting
15	Input/Output Powered Extension Units
16	Input/Output Extension Blocks
17	Extension Power Supply Unit
18	Other Extension Units and Options
19	Display Module
20	Terminal Block

20.8 FX-16EYT-TB, FX-16EYT-H-TB

The FX-16EYT(H)-TB is available by connecting it to a FX2N series output extension block (transistor).

Output Connector	
Connectable models	FX2N-16EYT-C (sink output)

The applications shown below are not supported.

Unsupported Applications	
Pulse outputs	Pulse Y output (PLSY) instruction, acceleration/deceleration setup (PLSR) instruction, pulse width modulation (PWM) instruction, DOG search zero return (DSZR) instruction, interruption positioning (DVIT) instruction, batch data positioning mode (TBL) instruction, absolute current value read (ABS) instruction, zero return (ZRN) instruction, variable speed pulse output (PLSV) instruction, drive to increment (DRVI) instruction, drive to absolute (DRVA) instruction
Time division input	Input matrix (MTR) instruction, hexadecimal input (HKY) instruction, digital switch (DSW) instruction, arrow switch (ARWS) instruction
Time division output	Seven segment with latch (SEGL) instruction, print (ASCII Code) (PR) instruction

20.8.1 Specifications

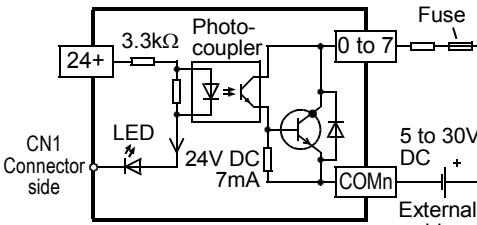
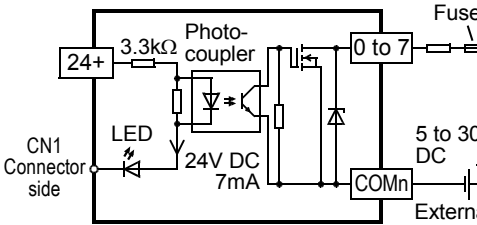
Item	Transistor output		
	FX-16EYT-TB	FX-16EYT-H-TB	
Input/output circuitry			
Load voltage	5 to 30V DC	5 to 30V DC	
Max. load	Resistance load	0.5 A / point The total load current of resistance loads per common terminal should be the following value: • 4 output points/common terminal: 0.8A or less	1 A / point The total load current of resistance loads per common terminal should be the following value: • 4 output points/common terminal: 3A or less
	Inductive load	12 W/24V DC	24 W/24V DC
Open-circuit leakage current	0.1 mA / 30V DC	0.1 mA / 30V DC	
Response time *1	OFF→ON*1	0.2 ms or less / 24V DC	0.3 ms or less / 24V DC
	ON→OFF*1	1.5 ms or less / 24V DC	4 ms or less / 24V DC
Output element's ON voltage	1.5 V	1.5 V	
Circuit isolation	Photo-coupler isolation	Photo-coupler isolation	
Operation indicators	LED is lit when photo-coupler power is supplied	LED is lit when photo-coupler power is supplied	
Power consumption	2.7 W (112 mA 24V DC)	2.7 W (112 mA 24V DC)	

*1. This response time does not include the response delay of the PLC.

20.8.2 Internal circuit

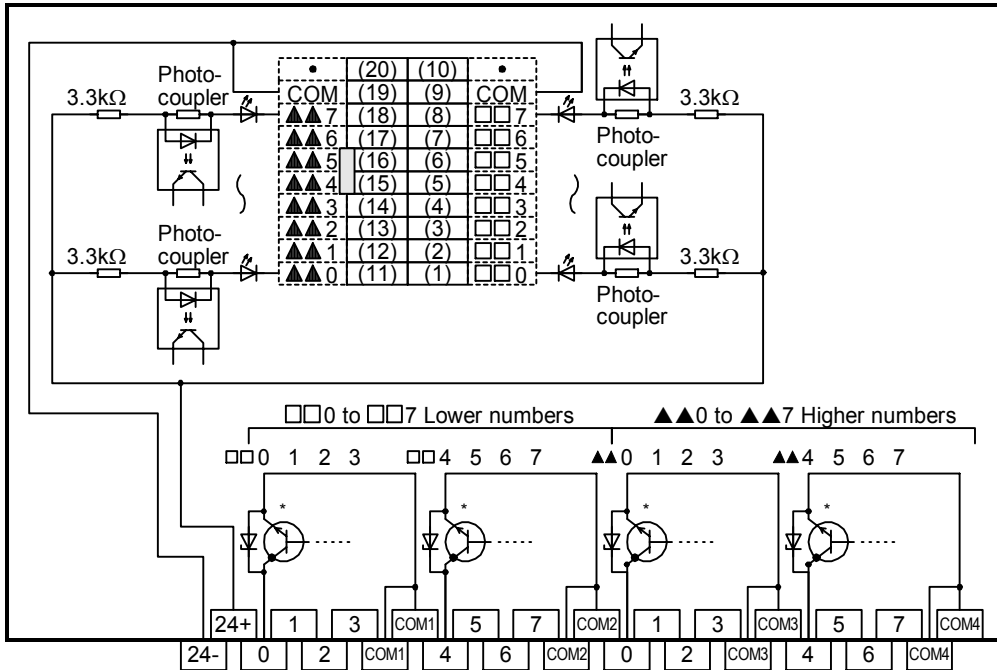

* For the FX-16EYT-H-TB, the output transistor elements are as shown in the figure below.

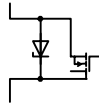

20.8.3 Example of output external wiring

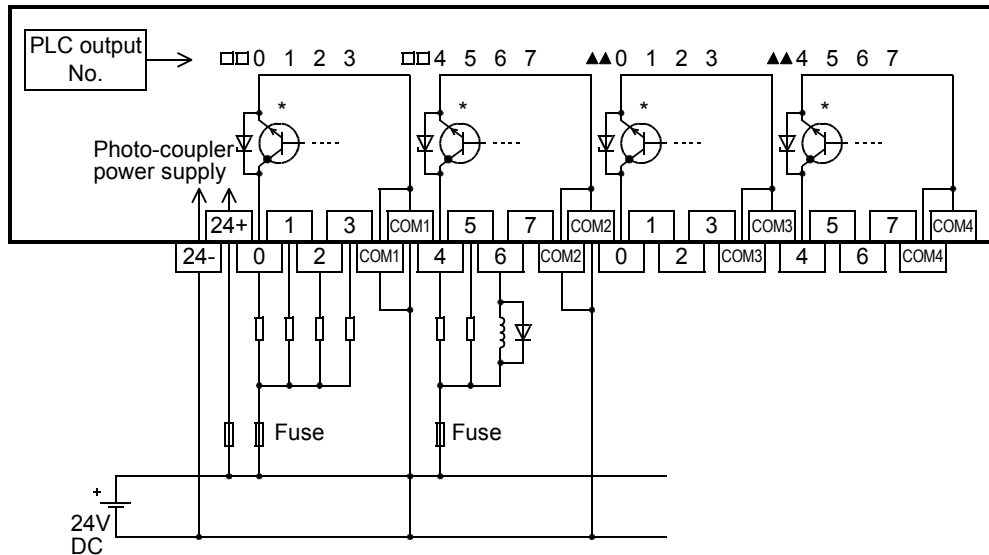

* For the FX-16EYT-H-TB, the output transistor elements are as shown in the figure below.

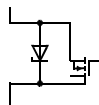

11	High-Speed Counters
12	Output Wiring
13	Wiring for Various Uses
14	Test Run, Maintenance, Troubleshooting
15	Input/Output Powered Extension Units
16	Input/Output Extension Blocks
17	Extension Power Supply Unit
18	Other Extension Units and Options
19	Display Module
20	Terminal Block

20.8.4 External wiring precautions

1. Protection circuit for load short-circuits

A short-circuit at a load connected to an output terminal could cause burnout at the output element or the PCB. To prevent this, a protection fuse should be inserted at the output. Use a load power supply capacity that is at least 2 times larger than the total rated fuse capacity.

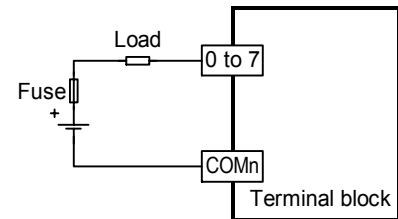

2. Transistor protection circuit for inductive loads

The transistor output circuit in the terminal block is equipped with a Zener diode (50V) for protection. When an inductive load is connected, however, a diode should be connected parallel to the load when required. The diode must comply with the specifications shown below.

Counter voltage	5 to 10 times of the load voltage
Forward current	Load current or more

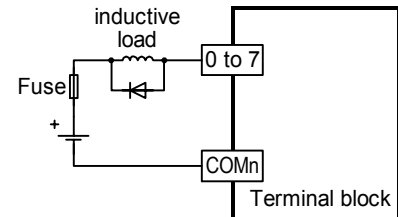

3. Interlock

For loads such as forward/reverse contactors, etc., where a hazardous condition could result if switched ON simultaneously, an external interlock should be provided for interlocking the PLC's internal programs as shown to the right.

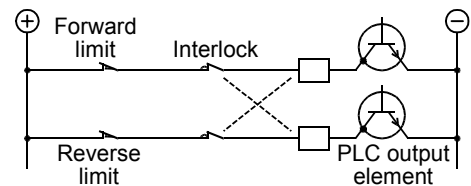

20.9 FX-16EYS-TB

The FX-16EYS-TB is available by connecting it to a FX2N series output extension block (transistor).

Output Connector	
Connectable models	FX2N-16EYT-C (sink output)

The applications shown below are not supported.

Unsupported Applications	
Pulse outputs	Pulse Y output (PLSY) instruction, acceleration/deceleration setup (PLSR) instruction, pulse width modulation (PWM) instruction, DOG search zero return (DSZR) instruction, interruption positioning (DVIT) instruction, batch data positioning mode (TBL) instruction, absolute current value read (ABS) instruction, zero return (ZRN) instruction, variable speed pulse output (PLSV) instruction, drive to increment (DRVI) instruction, drive to absolute (DRVA) instruction
Time division inputs	Input matrix (MTR) instruction, hexadecimal input (HKY) instruction, digital switch (DSW) instruction, arrow switch (ARWS) instruction
Time division outputs	Seven segment with latch (SEGL) instruction, print (ASCII Code) (PR) instruction

20.9.1 Specifications

Item	TRIAC output	
Input/output circuitry		
Load voltage	85 to 242V AC	
Max. load	Resistance load	0.3 A / point*1 The total load current of resistance loads per common terminal should be the following value: • 4 output points/common terminal: 0.8A or less
	Inductive load	15 VA / 100V AC 36 VA / 200V AC
Min. load	0.4 VA / 100V AC 1.6 VA / 200V AC	
Open-circuit leakage current	1 mA / 100V AC 2 mA / 200V AC	
Response time*2	2 ms or less	
Circuit isolation	Photocoupler isolation	
Operation indicator	LED is lit when photo-thyristor power is supplied	
Power consumption	2.7 W (112 mA 24V DC)	

*1. In systems where frequent large-load ON/OFF switching occurs due to rush currents, the root mean square current should be 0.2 A or less.

<Example>

$$\sqrt{\frac{4^2 \times 0.02 + 0.4^2 \times 0.7}{0.02 + 0.7 + 10}} = 0.2A$$

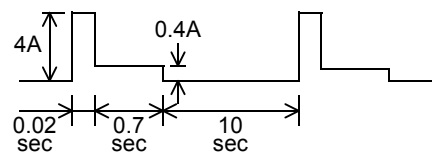

*2. This response time does not include the response delay of the PLC.

20.9.2 Internal circuit

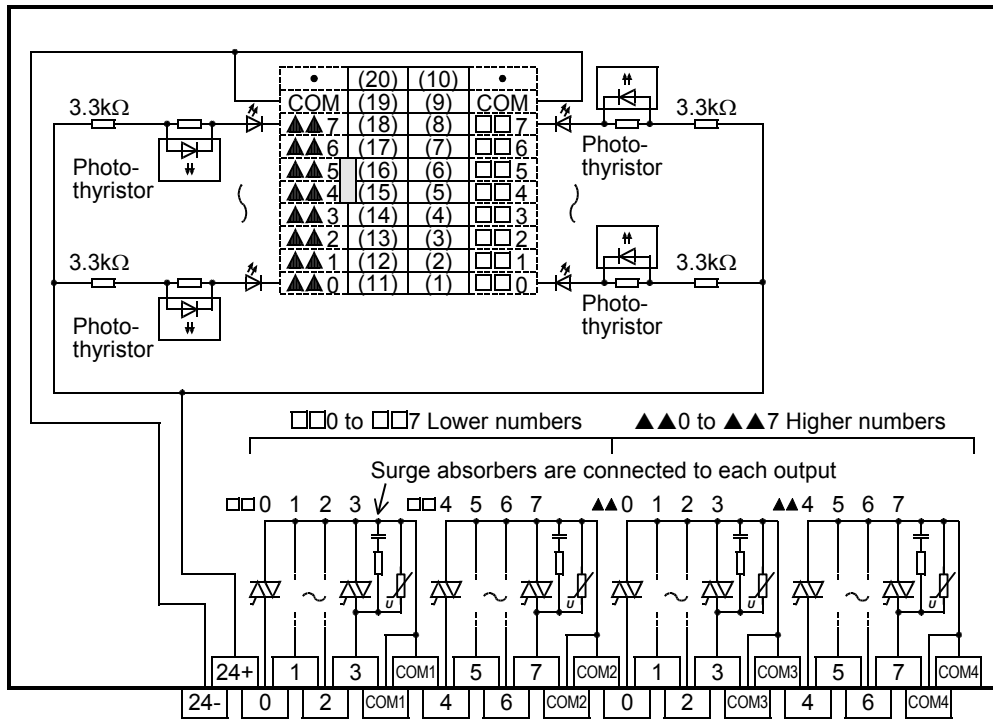

20.9.3 Example of output external wiring

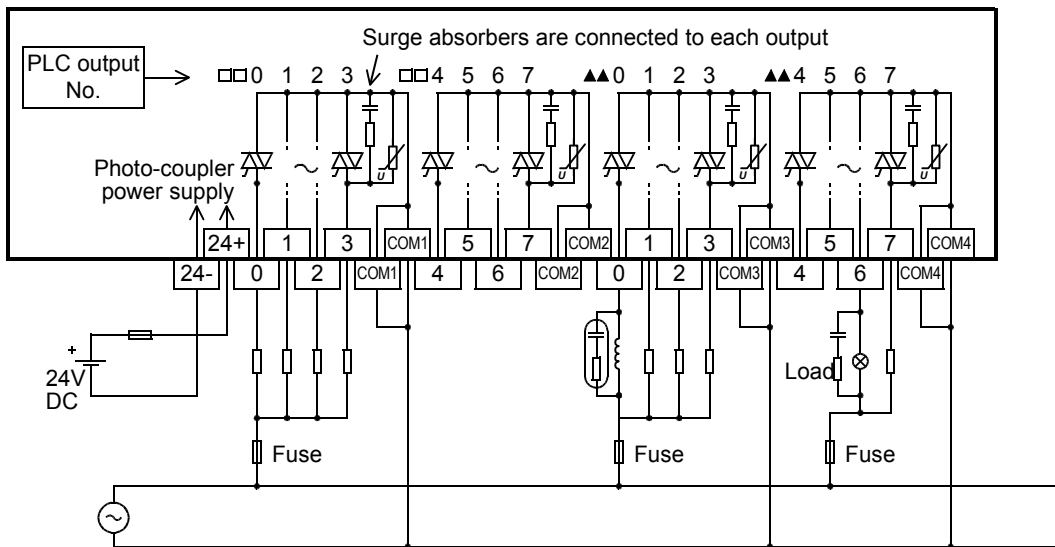

20.9.4 External wiring precautions

1. Protection circuit for load short-circuits

A short-circuit at a load connected to an output terminal could cause burnout at the output element or the PCB. To prevent this, a protection fuse should be inserted at the output.

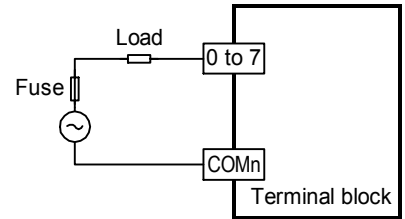

2. Micro current load

The PLC's internal Triac output circuit is equipped with a turn-off C-R absorber. When connecting a very low current load of "0.4VA/100V AC or less or 1.6 VA/200V AC or less", please connect a surge absorber parallel to the load.

Select the rated voltage of a surge absorber that is suitable for the load being used. Refer to the table below for other specifications.

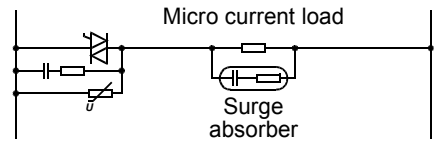

Item	Guide
Static electricity capacity	Approx. 0.1μF
Resistance value	Approx. 100 to 200Ω

Reference

Manufacturer	Model name
Okaya Electric Industries Co., Ltd.	CR-10201

Manufacturer	Model name
Rubycon Corporation	250MCRA104100M B0325

3. Interlock

For loads such as forward/reverse contactors, etc., where a hazardous condition could result if switched ON simultaneously, an external interlock should be provided for interlocking the PLC's internal programs as shown to the right.

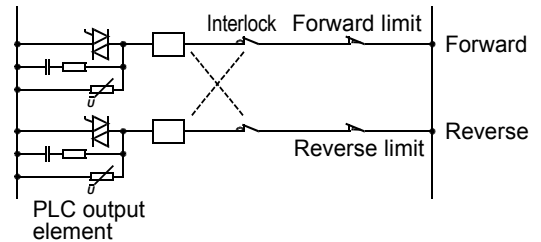

4. In-phase

PLC output contacts (*) should be used in an "in-phase" manner.

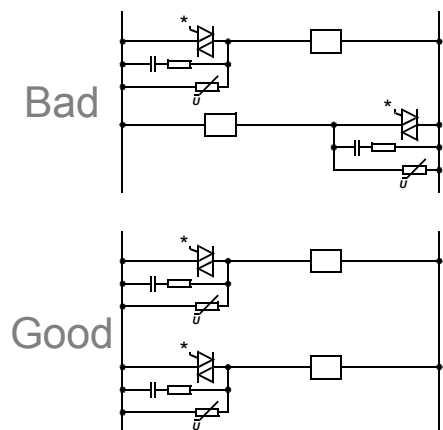

11	High-Speed Counters
12	Output Wiring
13	Wiring for Various Uses
14	Test Run, Maintenance, Troubleshooting
15	Input/Output Powered Extension Units
16	Input/Output Extension Blocks
17	Extension Power Supply Unit
18	Other Extension Units and Options
19	Display Module
20	Terminal Block

21. FX3U-FLROM-16/64/64L/1M (Memory Cassette)

STARTUP AND MAINTENANCE PRECAUTIONS



- Turn off the power to the PLC before attaching or detaching the memory cassette. If the memory cassette is attached or detached while the PLC's power is on, the data in the memory may be destroyed, or the memory cassette may be damaged.
- Do not disassemble or modify the PLC.
Doing so may cause fire, equipment failures, or malfunctions.
For repair, contact your local Mitsubishi Electric representative.

This chapter explains the memory cassette specifications and functions. The memory cassette can be installed at the main unit, and when installed, the memory cassette's internal program is used in place of the internal RAM memory.

21.1 Specifications

21.1.1 Electrical specifications

Model Name	Max. Memory Capacity	Memory Type	Max. Allowable Write	PROTECT Switch	Loader Function	Compatible Versions
FX3U-FLROM-1M	64000 steps (2k/4k/8k/16k/32k selectable) (There is an area (1300 kB) dedicated to the storage of symbolic information.)	Flash memory	10,000 times	Provided	NA	Ver. 3.00 or later
FX3U-FLROM-64L	64000 steps (2k/4k/8k/16k/32k selectable)	Flash memory	10,000 times	Provided	Provided	1st article (Ver. 2.20)
FX3U-FLROM-64	64000 steps (2k/4k/8k/16k/32k selectable)	Flash memory	10,000 times	Provided	NA	
FX3U-FLROM-16	16000 steps (2k/4k/8k selectable)	Flash memory	10,000 times	Provided	NA	

21.1.2 Component names & external dimensions

1. FX3U-FLROM-64L

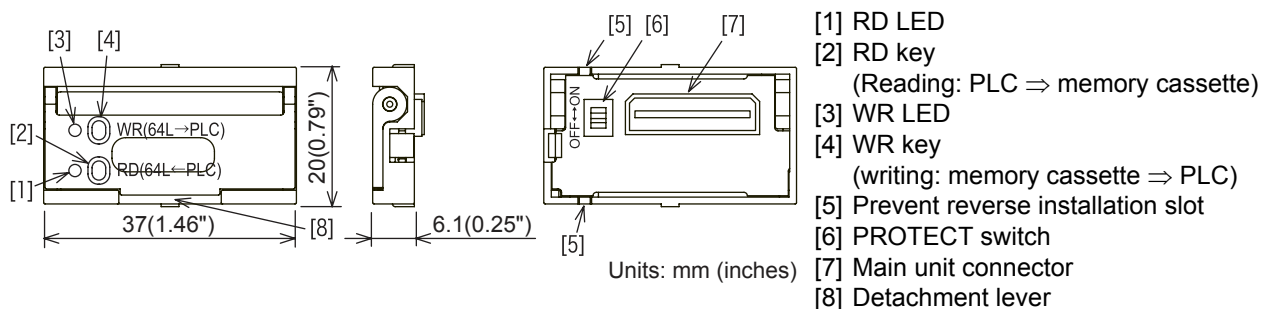

2. FX3U-FLROM-1M, FX3U-FLROM-64, FX3U-FLROM-16

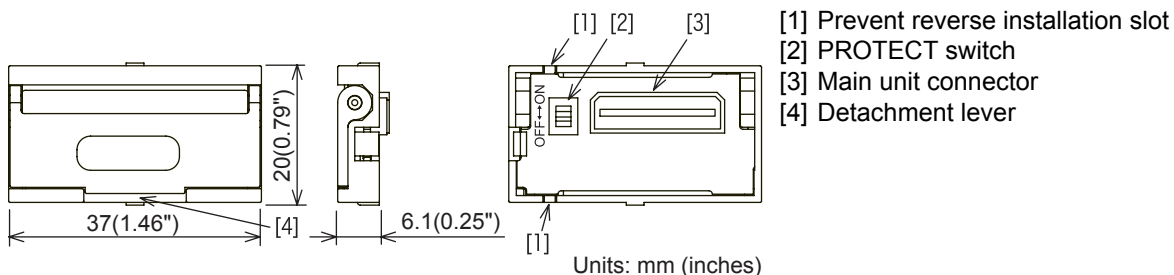

21.2 Installation & Removal

If a display module (FX3U-7DM) and a display module holder (FX3U-7DM-HLD) are installed, remove these items before installing or removing the memory cassette. Be sure that the power is OFF when installing/removing the memory cassette.

21.2.1 Memory cassette installation

1 Remove the top cover.

While pressing the top cover hook ("A"), remove the top cover ("B") as shown in the figure to the right.

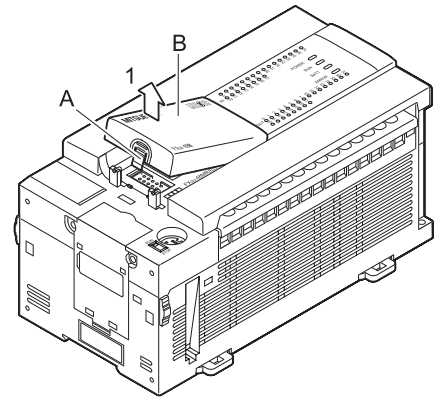

2 Raise the memory cassette detachment lever.

Raise the memory cassette detachment lever ("C").

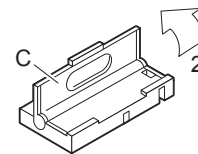

3 Install the memory cassette.

Align the cassette with the "prevent reverse installation slot" ("D"), then press it all the way in (when pressed all the way in, the cassette is approx. 0.4mm (0.02") lower than the surrounding surface.)

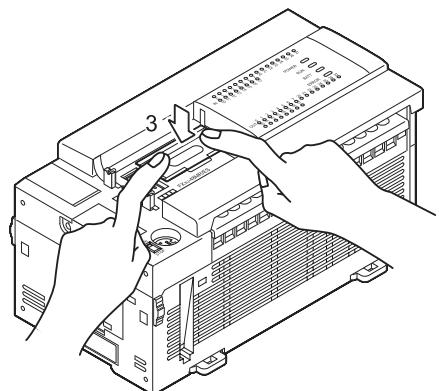
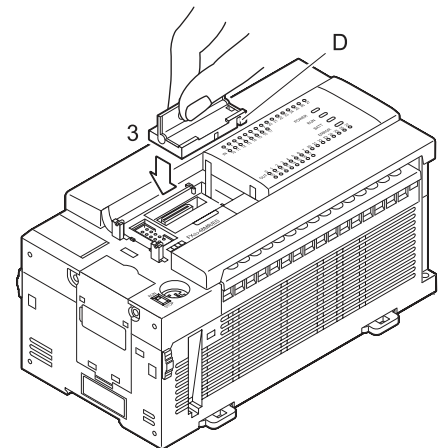

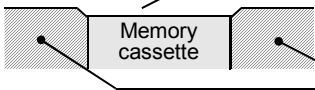
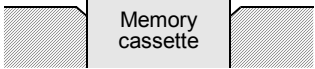
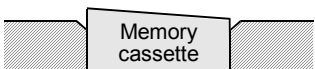
Installation precaution	 CAUTION	
<ul style="list-style-type: none"> Connect the memory cassette securely to the appropriate connector. Loose connections may cause malfunctions. Installing the cassette in a raised or tilted posture can also cause malfunctions. 		
<p>Cross-section drawing (memory cassette installation condition)</p> <p style="text-align: center;">Press the 4 corners in approx. 0.4mm(0.02")</p>		
Good		PLC body
Bad		Raised cassette posture
Bad		Tilted cassette posture

4 Attach the top cover ("B").

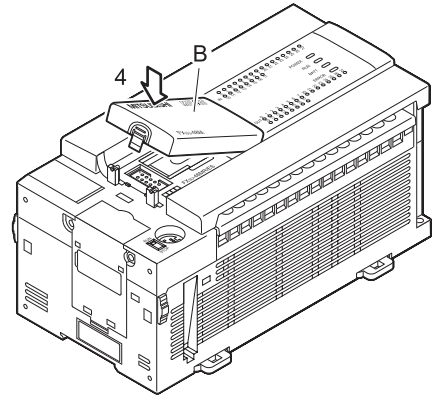

21.2.2 Memory cassette removal

1 Remove the top cover.

While pressing the top cover hook ("A"), remove the top cover ("B") as shown in the figure to the right.

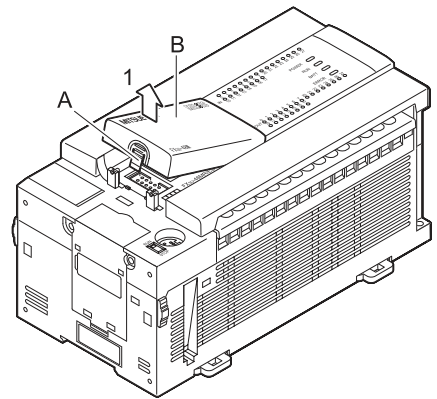

2 Raise the memory cassette detachment lever.

Raise the memory cassette detachment lever ("C").

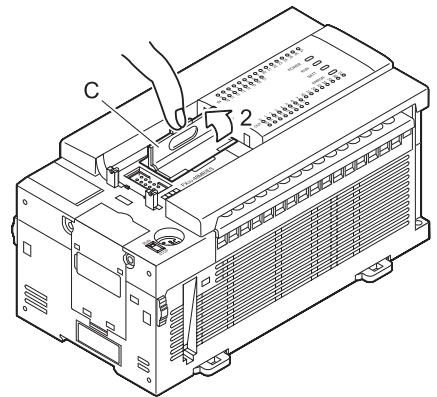

3 Grasp the detachment lever and pull it.

Grasp the detachment lever ("C") and pull it vertically to remove the memory cassette.

Caution:

Take care to avoid twisting the detachment lever when removing the memory cassette.

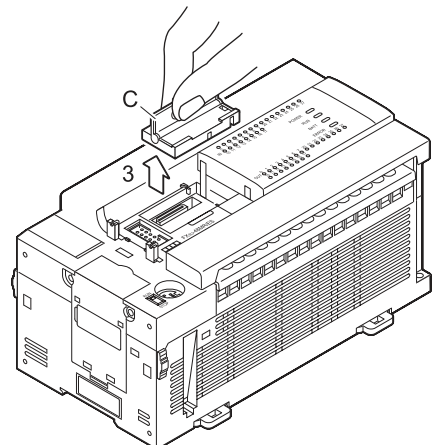

21.3 Saved Data Content

The following data is saved on the memory cassette.

Item	Description	Saving Method	
Program Memory	Parameters <ul style="list-style-type: none"> Memory capacity setting <ul style="list-style-type: none"> Memory capacity (default setting: 16k steps) 2k/4k/8k/16k steps (FX3U-FLROM-16) 2k/4k/8k/16k/32k/64k steps (FX3U-FLROM-64/64L/1M) Comment capacity File register capacity Special Function Memory capacity 	Programming tool *4	
	Sequence programs		User-created sequence programs
	Comments		Max. 6350 points (0 to 127 blocks, 1 block = 50 points / 500 steps)
	File registers		Max. 7000 points (0 to 14 blocks, 1 block = 500 points / 500 steps)
		Comments and file registers can be created in the memory by setting them in the parameter memory capacity.*3	
	Symbolic information <ul style="list-style-type: none"> FX3U-FLROM-16, FX3U-FLROM-64/64L Symbolic information capacity = Max. capacity of memory cassette - Memory capacity set by parameters FX3U-FLROM-1M Symbolic information can be stored in the dedicated area (1300 kB). 	GX Works2*5	
Extended file registers	ER0 to ER32767 (32768 points)	<ul style="list-style-type: none"> Sequence program GX Works2 GX Developer 	

- *1. This function is supported in FX3U PLC Ver. 3.10 or later.
Do not connect a memory cassette with special parameters saved to any FX3U PLC earlier than Ver. 3.10.
- *2. This function is supported in GX Works2 Ver. 1.73B or later.
- *3. The total size of the programs + comments + file registers must not exceed the maximum capacity of the memory cassette.
- *4. The maximum number of points for the memory capacity, comments, and file registers, can be specified when the FX3U(C) programming tool is selected. The maximum number of points cannot be specified when a programming tool other than the FX3U(C) is selected.
- *5. It is possible to check the symbolic information capacity using the memory capacity calculation (offline) of GX Works2.
Refer to the GX Works2 Version 1 Operating Manual (Common) for details.

Cautions on using the symbolic information

The FX3U PLC Ver. 3.00 or later can store symbolic information.
Note the following cautions when using symbolic information.

- When symbolic information is stored, it is deleted if the memory capacity set by parameters is changed. After changing the memory capacity, write the symbolic information again.
- Memory cassettes (except for the FX3U-FLROM-1M) which are storing symbolic information can be used by FX3U PLCs whose version is earlier than Ver. 3.00. In this case, the FX3U PLC operates, but the written symbolic information is invalid.
- For writing symbolic information and changing the set values of timers and counters using a peripheral device, it is recommended to create programs with set values specified indirectly.
If the set values are specified directly, programs cannot be restored from symbolic information after the set values are changed.

21.4 PROTECT Switch

21.4.1 PROTECT switch setting

Reading from and writing to memory cassette operations can be performed by using the programming tool.

Because sequence programs are written by an electronic format, a special ROM writer and ultraviolet eraser are not required.

The PROTECT switch must be turned OFF to enable writing.

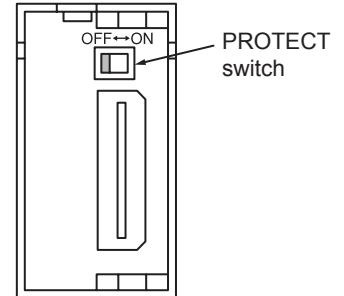

21.4.2 PROTECT switch operation

1. Preparing the operation tools

Set the PROTECT switch knob by using the tip of a pair of tweezers, a precision screwdriver, or a tool with a tip width of approx. 0.8mm (0.04").

Do not use objects with round tips, as the round tip can easily slip off the switch knob, possibly resulting in an incorrect setting.

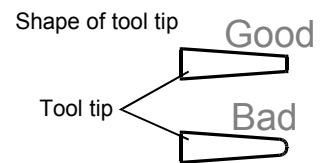

2. Switch operation procedure

As shown in the figure below, the switch knob can be "pushed" or "pulled". When setting the switch, do not set it in an intermediate position.

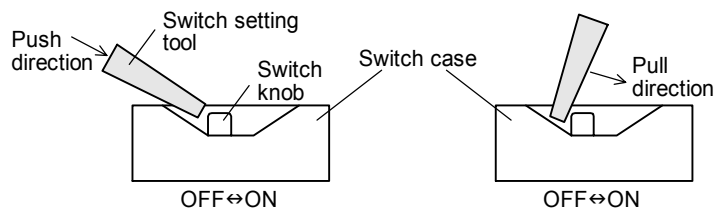

21.4.3 Precautions when setting and using the switch

- Leaving the switch knob at an intermediate position for an extended period can cause an equipment failure.
- Also use care to avoid scratching the PCB when setting the switch.

21.5 Memory Cassette <-> PLC (RAM Memory) Transfers Using the Loader Function

The FX3U-FLROM-64L loader function ([WR] and [RD] key operation) is explained in this section.

- Program transfers (reading/writing) are possible between the memory cassette and the PLC's internal RAM memory.
- The loader function is enabled while the PLC is stopped.

21.5.1 Tool for pressing the [WR] and [RD] keys

Use an insulated tool (plastic, ceramic, etc.) to press the [WR] and [RD] keys. The area around the keys is not insulated. Using a metal screwdriver, etc can cause equipment damage.

21.5.2 Writing (WR: 64L → PLC)

A memory cassette program is written to the PLC's internal RAM memory.

Required condition: The PLC must be stopped.

1 Install the memory cassette on the main unit.

(Setting the PROTECT switch to ON (on memory cassette's rear face) prevents accidental overwriting of memory cassette program.)

→ Refer to Subsection 21.2.1 for the installation procedure.

- Verify that the PLC power is OFF, then install the memory cassette on the PLC.
- Turn the PLC power ON.
- Raise the memory cassette's eject lever.

2 Press the [WR] key 1 time.

The [WR] LED is lit, and a preparation status is established.

- To cancel, press the [RD] key.

3 Press the [WR] key again.

Writing is executed, and the [WR] LED turns off.

- Writing to the built-in RAM is completed instantaneously, and the LED will turn off in a short time.

4 Remove the memory cassette from the main unit.

Writing is completed when the [WR] LED turns off.

After turning the PLC power OFF, remove the memory cassette from the PLC.

→ Refer to Subsection 21.2.2 for the removal procedure.

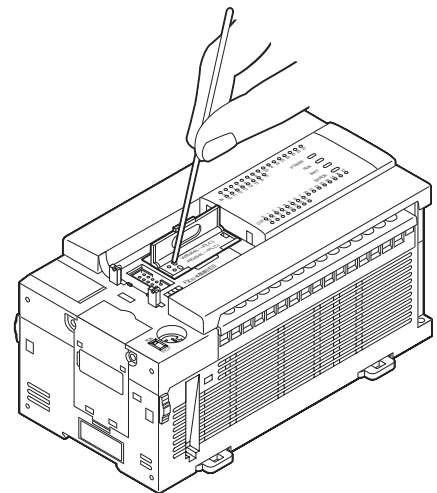
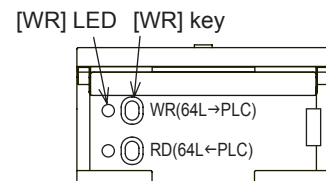

21.5.3 Reading (RD: 64L ← PLC)

Programs are read from the PLC's internal RAM memory to the memory cassette.

Required condition: The PLC must be stopped, and the PROTECT switch must be OFF.

1 Turn the PROTECT switch OFF on the back of the memory cassette.

The memory cassette must be removed from the PLC in order to turn the PROTECT switch OFF. Make sure that the PLC power is OFF before removing the memory cassette.

→ Refer to Subsection 21.2.2 for the removal procedure.

2 Install the memory cassette on the main unit.

→ Refer to Subsection 21.2.1 for the installation procedure.

- Verify that the PLC power is OFF, then install the memory cassette on the PLC.
- Turn the PLC power ON.
- Raise the memory cassette's eject lever.

3 Press the [RD] key 1 time.

The [RD] LED is lit, and a preparation status is established.

- To cancel, press the [WR] key.

4 Press the [RD] key again.

Reading is executed, and the [RD] LED blinks.

5 Remove the memory cassette from the main unit.

Reading is completed when the [RD] LED turns off.

After turning the PLC power OFF, remove the memory cassette from the PLC, then turn the PROTECT switch ON.

→ Refer to Subsection 21.2.2 for the removal procedure.

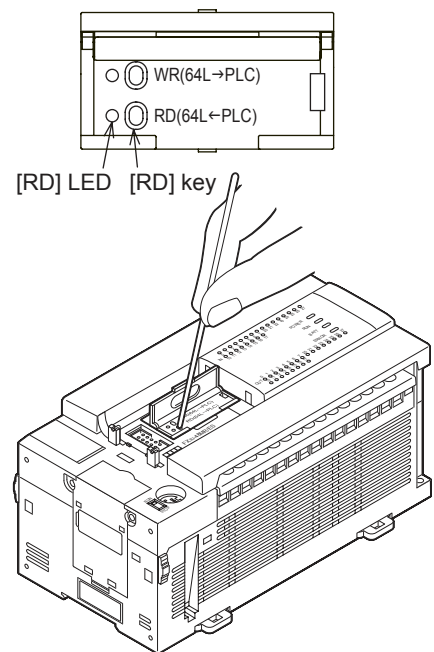

21.6 Transfers By Display Module Operation

Programs can be transferred (reading/writing) between the memory cassette and the PLC's internal RAM memory by a display module operation.

→ Refer to Section 19.17 for the memory cassette transfer function.

21.7 Operation Precautions

Observe the following precautions when writing to file registers (D) and extended file registers (ER) by program.

1. Flash memory writing count

10,000 writing operations are permitted at the flash memory.

2. Precaution for file register usage

Writing to the flash memory occurs at each PLC operation cycle if BMOV instructions are used in a continuous execution format with regard to a file register.

To prevent this, be sure to use "pulse execution format" BMOV instructions.

3. Precaution for extended file register (ER) usage

Do not use continuous constant-execution SAVED and LOGR instructions with regard to extended file registers. Use the individual instructions only when required.

22. FX3U-32BL (Battery)

STARTUP AND MAINTENANCE PRECAUTIONS	 DANGER
<ul style="list-style-type: none"> • Use the battery for memory backup correctly in conformance to this manual. <ul style="list-style-type: none"> - Use the battery only for the specified purpose. - Connect the battery correctly. - Do not charge, disassemble, heat, put in fire, short-circuit, connect reversely, weld, swallow or burn the battery, or apply excessive forces (vibration, impact, drop, etc.) to the battery. - Do not store or use the battery at high temperatures or expose to direct sunlight. - Do not expose to water, bring near fire or touch liquid leakage or other contents directly. - Incorrect handling of the battery may cause heat excessive generation, bursting, ignition, liquid leakage or deformation, and lead to injury, fire or failures and malfunctions of facilities and other equipment. 	

STARTUP AND MAINTENANCE PRECAUTIONS	 CAUTION
<ul style="list-style-type: none"> • Turn off the power to the PLC before attaching or detaching the following devices. Failure to do so may cause equipment failures or malfunctions. <ul style="list-style-type: none"> - Peripheral devices, display module, expansion boards, and special adapters - Extension units/blocks and FX Series terminal blocks - Battery and memory cassette 	

TRANSPORTATION AND STORAGE PRECAUTIONS	 CAUTION
<ul style="list-style-type: none"> • Before transporting the PLC, turn on the power to the PLC to check that the BATT LED is off. If the PLC is transported with the BATT LED on or the battery exhausted, the battery-backed data may be unstable during transportation. • When transporting lithium batteries, follow required transportation regulations. (For details of the regulated products, refer to Appendix E) 	

The main unit of the PLC has a built-in battery. When the battery voltage drops, the BATT LED is lit, and the special auxiliary relay (M8005 or M8006) turns on. In this case, replace the battery FX3U-32BL.

22.1 Battery Purpose

The battery is required to retain (backup) program memory and "latched device" data and maintain clock operation in the event of a power outage.

	Data Retained By Backup Battery
Program memory	Internal RAM parameters, programs, device comments, file registers, symbolic information
Device memory	<ul style="list-style-type: none"> • Auxiliary relay, state (for annunciator included), timer (cumulative type), counter, data register latched device • Extended register • Sampling trace result
Current time	Current time clock

22.2 Specifications

Item	Specifications	Remarks
Nominal voltage	3V	Battery voltage can be monitored with PLC data register D8005.

22.2.1 Differences between main unit's internal battery and the optional battery

Although the optional battery (FX3U-32BL) serves as the same as the main unit's internal battery, they differ in the ways described below.

They may also have different external colors based on the time of manufacture.

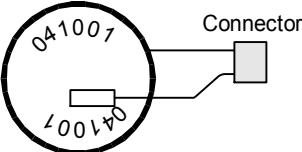
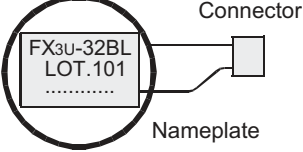
	Main Unit Internal Battery	Optional Battery (Spare)
External appearance		<p>A nameplate label with the product model and lot No. is affixed.</p> 

22.3 Battery Handling

When the battery voltage is low, a "BATT" LED is lit (red) while the power is ON, and M8005 and M8006 are switches ON.

Although the battery will continue to function for approximately 1 month after the "BATT" LED switches ON, a replacement battery should be ordered and installed as soon as possible.

22.3.1 Battery life & replacement guidelines

FX3U-32BL battery life : Approx. 5 years (ambient temperature : 25°C(77°F))

The life of the battery changes with respect to ambient temperature. When planning for battery replacement, please estimate the battery life according to the graph to the right and order replacement batteries in advance.

Battery life vs. temperature

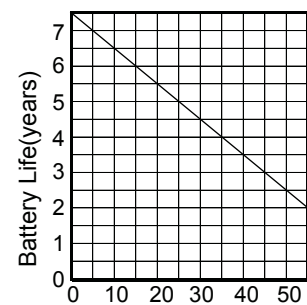

22.3.2 Reading the date of manufacture

1. Reading the optional battery's lot No. (reference)

Batteries with affixed nameplate labels are optional batteries.

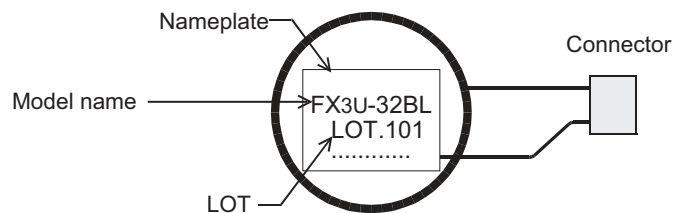

<Product during December, 2009 or earlier>

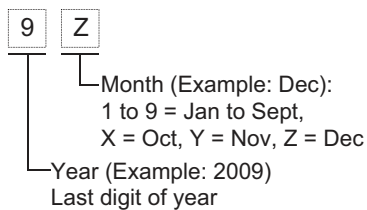

<Product from January, 2010>

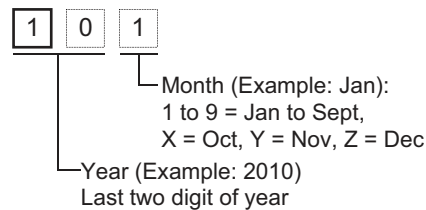

2. Reading the battery's year/month of manufacture [main unit's internal battery] (reference)

Batteries without affixed nameplate labels (refer to item 1. above) are main unit internal batteries.

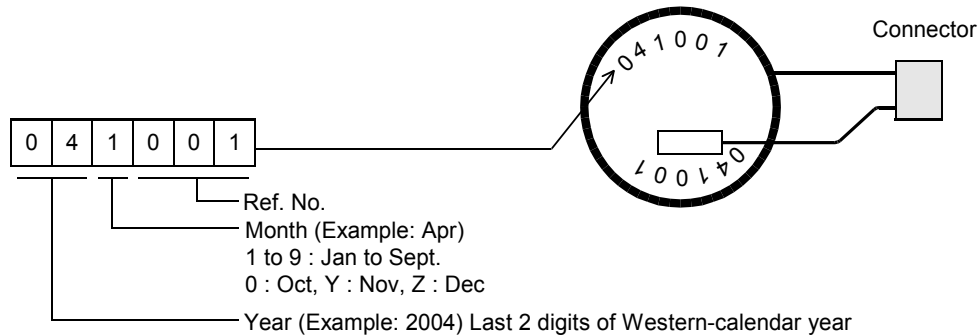

22.3.3 Special "battery low-voltage" device & notification program example

Prepare a system which allows constant external monitoring of the battery status, using an indicator lamp, etc.

- M8005

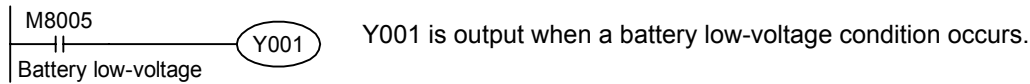

- M8006
Battery low-voltage is latched.
- D8005
Battery voltage can be monitored.

22.4 Battery-Free Operation

FX3U series operation is possible without a battery (PLC's internal battery removed) when the following conditions are satisfied.

→ Refer to the FX3U / FX3uc Programming Manuals for details concerning battery-free operation.

1. A memory cassette must be installed.
2. The following devices must not be used as "keep" devices.
Auxiliary relays, state (for annunciator included), timers (cumulative type), counters, data register "keep" device, extended registers.
3. The sampling trace function must be disabled.
4. The clock function must be disabled.

22.5 Battery Replacement

Before replacing the battery

Step 4 of the replacement procedure (below), must be performed within 20 seconds after step 3, or the memory content could be lost.

- 1 Turn the power OFF.
- 2 Remove the battery cover.

Slightly lift the "B" side of the battery cover ("A").

Grasp the cover ("A") between your fingers and remove it.

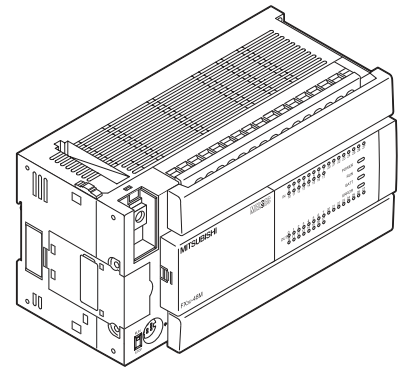
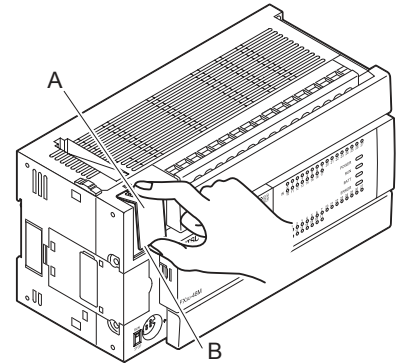

- 3 Remove the old battery.

Extract the old battery from the battery holder ("C"), and disconnect the battery connector ("D").

- 4 Install the new battery.

Connect the battery connector ("D") to the new battery, and insert the battery into the battery holder ("C").

- 5 Attach the battery cover ("A").

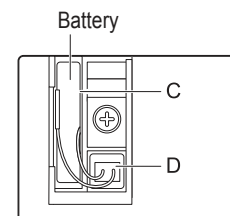

Caution

- 1) Battery replacement requires users to verify data integrity such as the PLC program (when a memory cassette is not attached), latched (battery backed) device values and RTC values. Before switching the PLC to RUN, ensure the safety of the operation.
- 2) If the battery backed data becomes unstable, clear the latched (battery backed) devices, and transfer the data again. Set the RTC and default values again if necessary.
→ For the clear method of keeping devices, refer to the programming manual.

22.6 Battery Related Precautions

1. The FX3U series uses a different battery type than those used for the FX2N (F2-40BL) and FX2NC (FX2NC-32BL) series.
 - Not for use with the FX3U series.
2. When performing battery-free operation, the clock stops when the main unit power is turned OFF.

Appendix A: Operation of Special Devices (M8000 -, D8000 -)

The device numbers and functions of the special auxiliary relays (indicated as "special M" in tables) and special data registers (indicated as "special D" in tables) are shown below.

Note that functions of certain devices vary depending on the series of the PLC.

Do not use the undefined / blank special auxiliary relays and special data registers in the sequence program since they are occupied by the CPU.

In addition, do not activate or write to the devices with brackets on the first letter such as [M]8000 or [D]8001 in the program.

→ For detailed explanation, refer to the Programming Manual.

Appendix A-1 Special Auxiliary Relay (M8000 to M8511)

Number and name	Operation and function	Corresponding special device	Number and name	Operation and function	Corresponding special device
PLC Status			Clock		
[M]8000 RUN monitor NO contact	RUN input	-	[M]8010	Not used	-
[M]8001 RUN monitor NC contact	M8061 Error occurrence	-	[M]8011	ON and OFF in 10 ms cycle 10 ms clock pulse (ON: 5 ms, OFF: 5 ms)	-
[M]8002 Initial pulse NO contact	M8000	-	[M]8012	ON and OFF in 100 ms cycle 100 ms clock pulse (ON: 50 ms, OFF: 50 ms)	-
[M]8003 Initial pulse NC contact	M8001	-	[M]8013	ON and OFF in 1 sec cycle 1 sec clock pulse (ON: 500 ms, OFF: 500 ms)	-
	M8002	-	[M]8014	ON and OFF in 1 min cycle 1 min clock pulse (ON: 30 sec, OFF: 30 sec)	-
	M8003	-	M 8015	Clock stop and preset For real time clock	-
		-	M 8016	Time read display is stopped For real time clock	-
[M]8004 Error occurrence	ON when either M8060, M8061, M8064, M8065, M8066, or M8067 is ON.	D8004	M 8017	±30 seconds correction For real time clock	-
[M]8005 Battery voltage low	ON when battery voltage is below the value set in D8006.	D8005	[M]8018	Installation detection (Always ON) For real time clock	-
[M]8006 Battery error latch	It is set when battery voltage low is detected.	D8006	M 8019	Real time clock (RTC) error For real time clock	-
[M]8007 Momentary power failure	ON for 1 scan, when detecting momentary power failure Even if M8007 turns ON, PLC continues to RUN mode in case duration of power loss is within period of time specified in D8008.	D8007 D8008	Flag		
[M]8008 Power failure detected	It is set when momentary power failure is detected. If power loss time is longer than period of time specified in D8008, M8008 is reset and PLC is turned in STOP mode.(M8000=OFF).	D8008	[M]8020 Zero	ON when the result of addition/subtraction is 0.	-
[M]8009 24V DC down	ON when 24V DC power fails in any I/O extension unit or special function unit/block.	D8009	[M]8021 Borrow	ON when the result of subtraction is less than the min. negative number.	-
			M 8022 Carry	ON when 'carry' occurs as a result of addition or when an overflow occurs as a result of shift operation.	-
			[M]8023	Not used	-
			M 8024*1	BMOV direction specification (FNC 15)	-
			M 8025*1	HSC mode (FNC 53 to 55)	-
			M 8026*1	RAMP mode (FNC 67)	-
			M 8027*1	PR mode (FNC 77)	-
			M 8028	Interrupt permission during FROM/TO (FNC 78 and 79) instruction execution	-
			[M]8029 Instruction execution complete	ON when operation such as DSW (FNC 72) is completed.	-

*1. Cleared when PLC switches from RUN to STOP.

Number and name	Operation and function	Corresponding special device
PLC Mode		
M 8030*1 Battery LED OFF	When M8030 set to ON, LED on PLC is not lit even if low battery voltage is detected.	-
M 8031*1 Non-latch memory all clear	If this special auxiliary relay is activated, the ON/OFF image memory of Y, M, S, T, and C, and present values of T, C, D, special data registers and R are cleared to zero.	-
M 8032*1 Latch memory all clear	However, file registers (D) in program memory, and extension file registers (ER) in the memory cassette are not cleared.	-
M 8033 Memory hold STOP	When PLC is switched from RUN to STOP, image memory and data memory are retained.	-
M 8034*1 All outputs disable	All external output contacts of PLC are turned OFF.	-
M 8035 Forced RUN mode	→Refer to Programming Manual for details.	-
M 8036 Forced RUN signal		-
M 8037 Forced STOP signal		-
[M]8038 Parameter setting	Communication parameter setting flag (for N:N network setting)	D8176 to D8180
M 8039 Constant scan mode	When M8039 is ON, PLC waits until scan time specified in D8039 and then executes cyclic operation.	D8039

*1. Executed at END instruction

Step Ladder and Annunciator		
M 8040 Transfer disable	While M8040 is turned ON, transfer between states is disabled.	-
[M]8041*2 Transfer start	Transfer from initial state is enabled in automatic operation mode.	-
[M]8042 Start pulse	Pulse output is given in response to a start input.	-
M 8043*2 Zero return complete	Set this in the last state of zero return mode.	-
M 8044*2 Zero point condition	Set this when machine zero return is detected.	-
M 8045 All output reset disable	Disables the 'all output reset' function when the operation mode is changed.	-
[M]8046*3 STL state ON	ON when M8047 is ON and either of S0 to S899 or S1000 to S4095 is active.	M8047
M 8047*3 STL monitoring enable	D8040 to D8047 are enabled when M8047 is ON.	D8040 to D8047
[M]8048*3 Annunciator operate	ON when M8049 is ON and either of S900 to S999 is ON.	-
M 8049*2 Annunciator enable	D8049 is enabled when M8049 is ON.	D8049 M8048

*2. Cleared when PLC switches from RUN to STOP.

*3. Executed at END instruction.

Number and name	Operation and function	Corresponding special device
Interrupt Disable		
M8050 (input interrupt) I00□ disable*4	<ul style="list-style-type: none"> If an input interrupt or timer interrupt occurs while a special auxiliary relay for that interrupt (M8050 - M8058) is ON, the interrupt will not operate. For example, turning M8050 ON disables the I00□ interrupt; hence, the interrupt routine is not processed even in an allowable program area. If an input interrupt or timer interrupt occurs while a special auxiliary relay for that interrupt (M8050 - M8058) is OFF, <ol style="list-style-type: none"> The interrupt will be accepted. The interrupt routine will be processed promptly if it is permitted by the EI (FNC 04) instruction. However, if the DI (FNC 05) instruction disables interrupts, the interrupt program will not be processed until EI (FNC 04) permits the interrupts. 	-
M8051 (input interrupt) I10□ disable*4		-
M8052 (input interrupt) I20□ disable*4		-
M8053 (input interrupt) I30□ disable*4		-
M8054 (input interrupt) I40□ disable*4		-
M8055 (input interrupt) I50□ disable*4		-
M8056 (Timer interrupt) I6□□ disable*4		-
M8057 (Timer interrupt) I7□□ disable*4		-
M8058 (Timer interrupt) I8□□ disable*4	-	
M8059 Counter interrupt disable*4	Interrupt of I010 to I060 disabled	-

*4. Cleared when PLC switches from RUN to STOP.

Error Detection		
[M]8060	I/O configuration error	D8060
[M]8061	PLC hardware error	D8061
[M]8062	Not used	-
[M]8063*5*6	Serial communication error 1 [ch1]	D8063
[M]8064	Parameter error	D8064
[M]8065	Syntax error	D8065 D8069 D8314 D8315
[M]8066	Ladder error	D8066 D8069 D8314 D8315
[M]8067*7	Operation error	D8067 D8069 D8314 D8315
M 8068	Operation error latch	D8068 D8312 D8313
M 8069*8	I/O bus check	-

*5. Cleared when PLC power supply is turned from OFF to ON.

*6. Serial communication error 2 [ch2] PLC is detected by M8438.

*7. Cleared when PLC switches from STOP to RUN.

*8. When M8069 is ON, I/O bus check is executed.

Number and name	Operation and function	Corresponding special device
Parallel Link		
M 8070*1	Parallel link Set M8070 when using master station.	-
M 8071*1	Parallel link Set M8071 when using slave station.	-
[M]8072	Parallel link ON when operating	-
[M]8073	Parallel link ON when M8070 or M8071 setting is incorrect	-

*1. Cleared when PLC switches from STOP to RUN.

Sampling Trace		
[M]8074	Not used	-
[M]8075	Ready request for sampling trace	D8075 to D8098
[M]8076	Start request for sampling trace	
[M]8077	ON during sampling trace	
[M]8078	ON when sampling trace is completed	
[M]8079	Sampling trace system area	-
[M]8080	Not used	-
[M]8081		-
[M]8082		-
[M]8083		-
[M]8084		-
[M]8085		-
[M]8086		-
[M]8087		-
[M]8088		-
[M]8089		-

Flag		
[M]8090	BKCOMP (FNC194 to FNC199) instructions - Block comparison signal	-
M 8091	COMRD (FNC182) and BINDA (FNC261) instructions - Output character quantity selector signal	-
[M]8092	Not used	-
[M]8093		-
[M]8094		-
[M]8095		-
[M]8096		-
[M]8097		-
[M]8098		-

High-Speed Ring Counter		
M 8099*2	High-speed ring counter operation (in 0.1ms units, 16 bits)	D8099
[M]8100	Not used	-

*2. 0.1ms high-speed ring counter D8099 will operate after M8099 turns ON.

Number and name	Operation and function	Corresponding special device
Memory Information		
[M]8101	Not used	-
[M]8102		-
[M]8103		-
[M]8104		-
[M]8105	ON during writing in RUN mode*3	-
[M]8106	Not used	-
[M]8107	Device comment registration check	D8107
[M]8108	Not used	-

Output Refresh Error		
[M]8109	Output refresh error	-
[M]8110	Not used	-
[M]8111		-
M 8112		-
M 8113		-
M 8114		-
M 8115		-
M 8116		-
M 8117		-
[M]8118		-
[M]8119		-

RS (FNC 80) and Computer Link [ch1]		
[M]8120	Not used	-
[M]8121*4	RS (FNC 80) instruction: Send wait flag	-
M 8122*4	RS (FNC 80) instruction: Send request	D8122
M 8123*4	RS (FNC 80) instruction: Receive complete flag	D8123
[M]8124	RS (FNC 80) instruction: Carrier detection flag	-
[M]8125	Not used	-
[M]8126	Computer link [ch1]: Global ON	D8127 D8128 D8129
[M]8127	Computer link [ch1]: On-demand send processing	
M 8128	Computer link [ch1]: On-demand error flag	
M 8129	Computer link [ch1]: On-demand Word/Byte changeover RS (FNC 80) instruction: Time-out check flag	

*3. Enabled only when a memory cassette is installed.

*4. Cleared when PLC switches from RUN to STOP or RS instruction is OFF.

21	Memory Cassette
22	Battery
A	Special Devices (M8000-, D8000-)
B	Instruction List
C	Character-code
D	Discontinued models
E	Precautions for battery transportation
F	Handling of batteries in EU member states

Number and name	Operation and function	Corresponding special device	
High-Speed Counter Comparison, High-Speed Table, and Positioning			
M 8130	HSZ (FNC 55) instruction: Table comparison mode	D8130	
[M]8131	HSZ (FNC 55) instruction: Table comparison mode completion flag		
M 8132	HSZ (FNC 55) and PLSY (FNC 57) instructions: Speed pattern mode	D8131 to D8134	
[M]8133	HSZ (FNC 55) and PLSY (FNC 57) instructions: Speed pattern mode completion flag		
[M]8134	Not used		-
[M]8135			-
[M]8136			-
[M]8137		-	
[M]8138	HSCT (FNC280) instruction: Instruction execution complete flag	D8138	
[M]8139	HSCS(FNC 53), HSCR(FNC 54), HS2(FNC 55), HSCT(FNC280) instructions: High-speed counter comparison instruction executing	D8139	
M 8140	ZRN (FNC156) instruction: CLR signal output function enable	-	
[M]8141	Not used	-	
[M]8142		-	
[M]8143		-	
[M]8144		-	
M 8145		-	
M 8146		-	
[M]8147		-	
[M]8148		-	
[M]8149		-	
Inverter Communication Function			
[M]8150	Not used	-	
[M]8151	Inverter communication in execution [ch1]	D8151	
[M]8152*1	Inverter communication error [ch1]	D8152	
[M]8153*1	Inverter communication error latch [ch1]	D8153	
[M]8154*1	IVBWR (FNC274) instruction error [ch1]	D8154	
[M]8155	Not used	-	
[M]8156	Inverter communication in execution [ch2]	D8156	
[M]8157*1	Inverter communication error [ch2]	D8157	
[M]8158*1	Inverter communication error latch [ch2]	D8158	
[M]8159*1	IVBWR (FNC274) instruction error [ch2]	D8159	

*1. Cleared when PLC switches from STOP to RUN.

Number and name	Operation and function	Corresponding special device
Advanced Function		
M 8160*2	SWAP function of XCH (FNC 17)	-
M 8161*2*3	8-bit process mode	-
M 8162	High-speed parallel link mode	-
[M]8163	Not used	-
M 8164		-
M 8165*2	SORT2 (FNC149) instruction: Sorting in descending order	-
[M]8166	Not used	-
M 8167*2	HKY (FNC 71) instruction: HEX data handling function	-
M 8168*2	SMOV (FNC 13) instruction: HEX data handling function	-
[M]8169	Not used	-

*2. Cleared when PLC switches from RUN to STOP.

*3. Applicable to ASC (FNC 76), RS (FNC 80), ASCII (FNC 82), HEX (FNC 83), CCD (FNC 84), and CRC (FNC188) instructions.

Pulse Catch		
M 8170*4	Input X000 pulse catch	-
M 8171*4	Input X001 pulse catch	-
M 8172*4	Input X002 pulse catch	-
M 8173*4	Input X003 pulse catch	-
M 8174*4	Input X004 pulse catch	-
M 8175*4	Input X005 pulse catch	-
M 8176*4	Input X006 pulse catch	-
M 8177*4	Input X007 pulse catch	-

*4. Cleared when PLC switches from STOP to RUN. EI (FNC 04) instruction is necessary.

Communication Port Channel Setting		
M 8178	Parallel link channel switch (OFF: ch1/ON: ch2)	-
M 8179	N:N network channel switch*5	-

*5. The channel is specified by either creating or not creating M8179 in setting program.

- ch1: not creating M8179 in setting program
- ch2: creating M8179 in setting program

Number and name	Operation and function	Corresponding special device
N:N Network		
[M]8180	Not used	-
[M]8181		-
[M]8182		-
[M]8183	Data communication error (Master station)	D8201 to D8218
[M]8184	Data communication error (Slave station No.1)	
[M]8185	Data communication error (Slave station No.2)	
[M]8186	Data communication error (Slave station No.3)	
[M]8187	Data communication error (Slave station No.4)	
[M]8188	Data communication error (Slave station No.5)	
[M]8189	Data communication error (Slave station No.6)	
[M]8190	Data communication error (Slave station No.7)	
[M]8191	Data communication in execution	
[M]8192	Not used	
[M]8193		-
[M]8194		-
[M]8195		-
[M]8196		-
[M]8197		-
High-Speed Counter Edge Count Specification		
M 8198 ^{*1*2}	C251, C252, C254: 1/4 edge count selector	-
M 8199 ^{*1*2}	C253, C255, or C253 (OP): 1/4 edge count selector	-

*1. OFF: 1 edge count
ON: 4 edge count

*2. Cleared when PLC switches from RUN to STOP.

Number and name	Operation and function	Corresponding special device
Counter Up/down Counter Counting Direction		
M 8200	C200	-
M 8201	C201	-
M 8202	C202	-
M 8203	C203	-
M 8204	C204	-
M 8205	C205	-
M 8206	C206	-
M 8207	C207	-
M 8208	C208	-
M 8209	C209	-
M 8210	C210	-
M 8211	C211	-
M 8212	C212	-
M 8213	C213	-
M 8214	C214	-
M 8215	C215	When M8□□□ is ON, the corresponding C□□□ is changed to down mode. • ON: Down count operation • OFF: Up count operation
M 8216	C216	
M 8217	C217	
M 8218	C218	
M 8219	C219	
M 8220	C220	
M 8221	C221	
M 8222	C222	
M 8223	C223	
M 8224	C224	
M 8225	C225	-
M 8226	C226	-
M 8227	C227	-
M 8228	C228	-
M 8229	C229	-
M 8230	C230	-
M 8231	C231	-
M 8232	C232	-
M 8233	C233	-
M 8234	C234	-
High-Speed Counter Up/down Counter Counting Direction		
M 8235	C235	-
M 8236	C236	-
M 8237	C237	-
M 8238	C238	When M8□□□ is ON, the corresponding C□□□ is changed to down mode. • ON: Down count operation • OFF: Up count operation
M 8239	C239	
M 8240	C240	
M 8241	C241	
M 8242	C242	
M 8243	C243	
M 8244	C244	
M 8245	C245	

21

Memory Cassette

22

Battery

A

Special Devices (M8000-, D8000-)

B

Instruction List

C

Character-code

D

Discontinued models

E

Precautions for battery transportation

F

Handling of batteries in EU member states

Number and name	Operation and function	Corresponding special device
High-Speed Counter Up/down Counter Monitoring		
[M]8246	C246	-
[M]8247	C247	-
[M]8248	C248	-
[M]8249	C249	-
[M]8250	C250	-
[M]8251	C251	-
[M]8252	C252	-
[M]8253	C253	-
[M]8254	C254	-
[M]8255	C255	-
[M]8256 to [M]8259	Not used	-
Analog Special Adapter (Refer to Appendix A-3 for details)		
M 8260 to M 8269 ^{*1}	1st special adapter	-
M 8270 to M 8279 ^{*1}	2nd special adapter	-
M 8280 to M 8289 ^{*1}	3rd special adapter	-
M 8290 to M 8299 ^{*1}	4th special adapter	-

*1. The number of connected analog special adapters is counted from the main unit side.

Flag		
[M]8300 to [M]8303	Not used	-
[M]8304 ^{*2} Zero	Turns ON when the multiplication or division result is 0.	-
[M]8305	Not used	-
[M]8306 ^{*2} Carry	Turns ON when the division result overflows.	-
[M]8307 to [M]8315	Not used	-

*2. Supported in Ver. 2.30 or later

Unconnected I/O Designation Error and flag		
[M]8316 ^{*3}	Unconnected I/O designation error	D8316 D8317
[M]8317	Not used	-
[M]8318	BFM initialization failure ON when a FROM/TO error has occurred in a special function block/unit as specified in the BFM initialization function at changing PLC from STOP to RUN. When M8318 turns ON, the unit number in which the error has occurred is stored in D8318, and the BFM number is stored in D8319.	D8318 D8319
[M]8319 to [M]8327	Not used	-
[M]8328	Instruction non-execution	-
[M]8329	Instruction execution abnormal end	-

*3. If the I/O device numbers are unavailable, M8316 turns ON when its directly designated to device numbers including LD, AND, OR, and OUT instructions or indirectly designated by index.

Number and name	Operation and function	Corresponding special device
Timing Clock		
[M]8330	DUTY (FNC186) instruction: Timing clock output 1	D8330
[M]8331	DUTY (FNC186) instruction: Timing clock output 2	D8331
[M]8332	DUTY (FNC186) instruction: Timing clock output 3	D8332
[M]8333	DUTY (FNC186) instruction: Timing clock output 4	D8333
[M]8334	DUTY (FNC186) instruction: Timing clock output 5	D8334
[M]8335	Not used	-
Positioning		
M 8336 ^{*4}	DVIT (FNC151) instruction: Interrupt input specification function enabled	D8336
[M]8337	Not used	-
M 8338	PLSV (FNC157) instruction: Acceleration/deceleration operation	-
[M]8339	Not used	-
[M]8340	[Y000] Pulse output monitor (ON: BUSY/ OFF: READY)	-
M 8341 ^{*4}	[Y000] Clear signal output function enable	-
M 8342 ^{*4}	[Y000] Zero return direction specification	-
M 8343	[Y000] Forward limit	-
M 8344	[Y000] Reverse limit	-
M 8345 ^{*4}	[Y000] DOG signal logic reverse	-
M 8346 ^{*4}	[Y000] Zero point signal logic reverse	-
M 8347 ^{*4}	[Y000] Interrupt signal logic reverse	-
[M]8348	[Y000] Positioning instruction activation	-
M 8349 ^{*4}	[Y000] Pulse output stop command	-

*4. Cleared when PLC switches from RUN to STOP.

Number and name	Operation and function	Corresponding special device
Positioning		
[M]8350	[Y001] Pulse output monitor (ON: BUSY/ OFF: READY)	-
M 8351*1	[Y001] Clear signal output function enable	-
M 8352*1	[Y001] Zero return direction specification	-
M 8353	[Y001] Forward limit	-
M 8354	[Y001] Reverse limit	-
M 8355*1	[Y001] DOG signal logic reverse	-
M 8356*1	[Y001] Zero point signal logic reverse	-
M 8357*1	[Y001] Interrupt signal logic reverse	-
[M]8358	[Y001] Positioning instruction activation	-
M 8359*1	[Y001] Pulse output stop command	-
[M]8360	[Y002] Pulse output monitor (ON: BUSY/ OFF: READY)	-
M 8361*1	[Y002] Clear signal output function enable	-
M 8362*1	[Y002] Zero return direction specification	-
M 8363	[Y002] Forward limit	-
M 8364	[Y002] Reverse limit	-
M 8365*1	[Y002] DOG signal logic reverse	-
M 8366*1	[Y002] Zero point signal logic reverse	-
M 8367*1	[Y002] Interrupt signal logic reverse	-
[M]8368	[Y002] Positioning instruction activation	-
M 8369*1	[Y002] Pulse output stop command	-
[M]8370*2	[Y003] Pulse output monitor (ON: BUSY/ OFF: READY)	-
M 8371*1*2	[Y003] Clear signal output function enable	-
M 8372*1*2	[Y003] Zero return direction specification	-
M 8373*2	[Y003] Forward limit	-
M 8374*2	[Y003] Reverse limit	-
M 8375*1*2	[Y003] DOG signal logic reverse	-
M 8376*1*2	[Y003] Zero point signal logic reverse	-
M 8377*1*2	[Y003] Interrupt signal logic reverse	-
[M]8378*2	[Y003] Positioning instruction activation	-
M 8379*1*2	[Y003] Pulse output stop command	-

*1. Cleared when PLC switches from RUN to STOP.

*2. Available only when two FX3U-2HSY-ADP units are connected to an FX3U PLC.

Number and name	Operation and function	Corresponding special device
High-Speed Counter Function		
[M]8380*3	Operation status of C235, C241, C244, C246, C247, C249, C251, C252, and C254	-
[M]8381*3	Operation status of C236	-
[M]8382*3	Operation status of C237, C242, and C245	-
[M]8383*3	Operation status of C238, C248, C248 (OP), C250, C253, and C255	-
[M]8384*3	Operation status of C239 and C243	-
[M]8385*3	Operation status of C240	-
[M]8386*3	Operation status of C244 (OP)	-
[M]8387*3	Operation status of C245 (OP)	-
[M]8388	Contact for high-speed counter function change	-
M 8389	External reset input logic reverse	-
M 8390	Function changeover device for C244	-
M 8391	Function changeover device for C245	-
M 8392	Function changeover device for C248 and C253	-

*3. Cleared when PLC switches from STOP to RUN.

Interrupt Program		
[M]8393	Contact for delay time setting	D8393
[M]8394	HCMOV (FNC189): Drive contact for interrupt program	-
[M]8395	Not used	-
[M]8396		-
[M]8397		-

Ring Counter		
M 8398	Ring counter operation (in 1ms units, 32 bits)*4	D8398, D8399
[M]8399	Not used	-

*4. 1ms ring counter (D8399, D8398) will operate after M8398 turns ON.

RS2 (FNC 87) [ch1]		
[M]8400	Not used	-
[M]8401*5	RS2 (FNC 87) [ch1] Send wait flag	-
M 8402*5	RS2 (FNC 87) [ch1] Send request	D8402
M 8403*5	RS2 (FNC 87) [ch1] Receive complete flag	D8403
[M]8404	RS2 (FNC 87) [ch1] Carrier detection flag	-
[M]8405*6	RS2 (FNC 87) [ch1] Data set ready (DSR) flag	-
[M]8406	Not used	-
[M]8407		-
[M]8408		-
M 8409	RS2 (FNC 87) [ch1] Time-out check flag	-

*5. Cleared when PLC switches from RUN to STOP or when the RS2 instruction [ch1] is OFF.

*6. Supported in Ver. 2.30 or later

Number and name	Operation and function	Corresponding special device
RS2 (FNC 87) [ch2] and Computer Link [ch2]		
[M]8410 to [M]8420	Not used	-
[M]8421 ^{*1}	RS2 (FNC 87) [ch2] Send wait flag	-
M 8422 ^{*1}	RS2 (FNC 87) [ch2] Send request	D8422
M 8423 ^{*1}	RS2 (FNC 87) [ch2] Receive complete flag	D8423
[M]8424	RS2 (FNC 87) [ch2] Carrier detection flag	-
[M]8425 ^{*2}	RS2 (FNC 87) [ch2] Data set ready (DSR) flag	-
[M]8426	Computer link [ch2] Global ON	D8427 D8428 D8429
[M]8427	Computer link [ch2] On-demand send processing	
M 8428	Computer link [ch2] On-demand error flag	
M 8429	Computer link [ch2] On-demand Word/Byte changeover RS2 (FNC 87) [ch2] Time-out check flag	

*1. Cleared when PLC switches from RUN to STOP or when RS2 instruction [ch2] is OFF.

*2. Supported in Ver. 2.30 or later

FX3U-CF-ADP [ch1]		
[M]8402 ^{*3}	CF-ADP instruction executing	-
[M]8403	Not used	-
[M]8404 ^{*3}	CF-ADP unit ready	-
[M]8405 ^{*3}	CF card mount status	-
[M]8406 to [M]8409	Not used	-
M 8410 ^{*3}	CF-ADP status renewal stop	-
[M]8411 to [M]8417	Not used	-
M 8418 ^{*3*4}	CF-ADP instruction error	-
FX3U-CF-ADP [ch2]		
[M]8422 ^{*3}	CF-ADP instruction executing	-
[M]8423	Not used	-
[M]8424 ^{*3}	CF-ADP unit ready	-
[M]8425 ^{*3}	CF card mount status	-
[M]8426 to [M]8429	Not used	-
M 8430 ^{*3}	CF-ADP status renewal stop	-
[M]8431 to [M]8437	Not used	-
M 8438 ^{*3*4}	CF-ADP instruction error	-

*3. Supported in Ver. 2.61 or later.

*4. Cleared when the PLC mode is changed from STOP to RUN.

Number and name	Operation and function	Corresponding special device
Error Detection		
[M]8430 to [M]8437	Not used	-
M 8438 ^{*5}	Serial communication error 2 [ch2]	D8438
[M]8439 to [M]8448	Not used	-
[M]8449	Special block error flag	D8449
[M]8450 to [M]8459	Not used	-
Positioning		
M 8460	DVIT (FNC151) instruction [Y000] User interrupt input command	D8336
M 8461	DVIT (FNC151) instruction [Y001] User interrupt input command	D8336
M 8462	DVIT (FNC151) instruction [Y002] User interrupt input command	D8336
M 8463 ^{*6}	DVIT (FNC151) instruction [Y003] User interrupt input command	D8336
M 8464	DSZR (FNC150), ZRN (FNC156) instructions [Y000] Clear signal device specification function enabled	D8464
M 8465	DSZR (FNC150), ZRN (FNC156) instructions [Y001] Clear signal device specification function enabled	D8465
M 8466	DSZR (FNC150), ZRN (FNC156) instructions [Y002] Clear signal device specification function enabled	D8466
M 8467 ^{*6}	DSZR (FNC150), ZRN (FNC156) instructions [Y003] Clear signal device specification function enabled	D8467
Error Detection		
[M]8468 to [M]8488	Not used	-
[M]8489 ^{*7}	Special parameter error	D8489
[M]8490 to [M]8511	Not used	-

*5. Cleared when PLC power supply is turned from OFF to ON.

*6. Available only when two FX3U-2HSY-ADP adapters are connected to a PLC.

*7. Supported in Ver. 3.10 or later.

Appendix A-2 Special Data Register (D8000 to D8511)

Number and name	Content of register	Corresponding special device					
PLC Status							
D 8000 Watchdog timer	Default value is 200ms (in 1ms steps) (Writes from system ROM at power ON) Value overwritten by program is valid after the END or WDT instruction execution.	-					
[D]8001 PLC type and system version	<table border="1" style="display: inline-table; vertical-align: middle;"> <tr> <td>2</td> <td>4</td> <td>2</td> <td>2</td> <td>0</td> </tr> </table> BCD converted value ↑ Version 2.20 ↑ FX3U, FX3UC, FX2N, FX2NC Series	2	4	2	2	0	D8101
2	4	2	2	0			
[D]8002 Memory capacity	<ul style="list-style-type: none"> • 2...2K steps • 4...4K steps • 8...8K steps • If 16K steps or more "8" is written to D8002 and "16" or "64" is written to D8102. 	D8102					
[D]8003 Memory type	Type of cassette or ON/OFF status of memory protect switch is stored.*1	-					
[D]8004 Error number M	<table border="1" style="display: inline-table; vertical-align: middle;"> <tr> <td>8</td> <td>0</td> <td>6</td> <td>0</td> </tr> </table> BCD converted value ↑ 8060 to 8068 (when M8004 is ON)	8	0	6	0	M8004	
8	0	6	0				
[D]8005 Battery voltage	<table border="1" style="display: inline-table; vertical-align: middle;"> <tr> <td></td> <td></td> <td></td> <td>3</td> <td>0</td> </tr> </table> BCD converted value (in 0.1V units) Battery voltage present value (Example: 3.0V)				3	0	M8005
			3	0			
[D]8006 Low battery voltage detection level	Default: 2.7V (in 0.1V units) (Writes from system ROM at power ON)	M8006					
[D]8007 Momentary power failure count	Operation frequency of M8007 is stored. Cleared at power OFF.	M8007					
D 8008 Power failure detection	Default: 10 ms (AC power supply type) 5 ms (DC power supply type)	M8008					
[D]8009 24V DC failed device	Lowest input device number of the I/O extension units in which 24V DC power has failed	M8009					

*1. D8003 becomes the undermentioned content.

Present value	Type of memory	Protect switch
02H	Flash memory cassette	OFF
0AH	Flash memory cassette	ON
10H	Built-in memory in PLC	-

Number and name	Content of register	Corresponding special device
Clock		
[D]8010 Present scan time *2	Accumulated instruction-execution time from step 0 (in 0.1ms units)	-
[D]8011 Minimum scan time*2	Minimum value of scan time (in 0.1ms units)	-
[D]8012 Maximum scan time*2	Maximum value of scan time (in 0.1ms units)	-
D 8013 Second data	0 to 59 seconds (for real time clock)	-
D 8014 Minute data	0 to 59 minutes (for real time clock)	-
D 8015 Hour data	0 to 23 hours (for real time clock)	-
D 8016 Day data	1 to 31 days (for real time clock)	-
D 8017 Month data	1 to 12 months (for real time clock)	-
D 8018 Year data	2 digits of year data (0 to 99) (for real time clock)	-
D 8019 Day-of-the-week data	0 (Sunday) to 6 (Saturday) (for real time clock)	-

*2. Indicated value includes waiting time of constant scan operations (when M8039 is activated).

Input Filter		
D 8020 Input filter adjustment	Input filter value of X000 to X017*3 (Default: 10 ms)	-
[D]8021	Not used	-
[D]8022		-
[D]8023		-
[D]8024		-
[D]8025		-
[D]8026		-
[D]8027		-

Index Register Z0 and V0		
[D]8028	Value of Z0 (Z) register*4	-
[D]8029	Value of V0 (V) register*4	-

*3. X000 to X007 in FX3u-16M□.

*4. The values of Z1 to Z7 and V1 to V7 are stored in D8182 to D8195.

21

Memory Cassette

22

Battery

A

Special Devices (M8000-, D8000-)

B

Instruction List

C

Character-code

D

Discontinued models

E

Precautions for battery transportation

F

Handling of batteries in EU member states

Number and name	Content of register	Corresponding special device
Constant Scan		
[D]8030	Not used	-
[D]8031		-
[D]8032		-
[D]8033		-
[D]8034		-
[D]8035		-
[D]8036		-
[D]8037		-
[D]8038		-
D 8039 Constant scan duration	Default: 0 ms (in 1 ms steps) (Writes from system ROM at power ON) Can be overwritten by program	M8039
Stepladder and Annunciator		
[D]8040*1 ON state number 1	The smallest number out of active state ranging from S0 to S899 and S1000 to S4095 is stored in D8040 and the second-smallest state number is stored in D8041. Active state numbers are then sequentially stored in registers up to D8047 (Max. 8 points).	M8047
[D]8041*1 ON state number 2		
[D]8042*1 ON state number 3		
[D]8043*1 ON state number 4		
[D]8044*1 ON state number 5		
[D]8045*1 ON state number 6		
[D]8046*1 ON state number 7		
[D]8047*1 ON state number 8		
[D]8048		
[D]8049*1 On state minimum number	When M8049 is ON, the smallest number out of active annunciator relay ranging from S900 to S999 is stored in D8049.	M8049
[D]8050 to [D]8059	Not used	-

*1. Executed at END instruction.

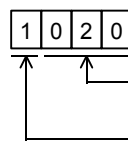
Number and name	Content of register	Corresponding special device
Error Detection (For the error code, refer to Subsection 14.6.4)		
[D]8060	If the unit or block corresponding to a programmed I/O number is not actually loaded, M8060 is set to ON and the first device number of the erroneous block is written to D8060. Example: If X020 is unconnected. 	M8060
[D]8061	Error code for PLC hardware error	M8061
[D]8062*2	Error code for PLC/PP communication error	M8062
[D]8063*2	Error code for serial communication error 1 [ch1]	M8063
[D]8064	Error code for parameter error	M8064
[D]8065	Error code for syntax error	M8065
[D]8066	Error code for ladder error	M8066
[D]8067*3	Error code for operation error	M8067
D 8068	Operation error step number latched*4	M8068
[D]8069*3	Error step number of M8065 to M8067*5	M8065 to M8067

*2. Cleared when PLC power supply is turned from OFF to ON.

*3. Cleared when PLC switches from STOP to RUN.

*4. In case of 32K steps or more, step number is stored in [D8313, D8312].

*5. In case of 32K steps or more, step number is stored in [D8315, D8314].

Parallel Link (Refer to Data Communication Edition for details.)		
[D]8070	Parallel link error time-out check time: 500 ms	-
[D]8071	Not used	-
[D]8072		-
[D]8073		-

Number and name	Content of register	Corresponding special device
Sampling Trace*1		
[D]8074	These devices are occupied by the PLC system when the sampling trace function is used in the personal computer*1.	M8075 to M8079
[D]8075		
[D]8076		
[D]8077		
[D]8078		
[D]8079		
[D]8080		
[D]8081		
[D]8082		
[D]8083		
[D]8084		
[D]8085		
[D]8086		
[D]8087		
[D]8088		
[D]8089		
[D]8090		
[D]8091		
[D]8092		
[D]8093		
[D]8094		
[D]8095		
[D]8096		
[D]8097		
[D]8098		

*1. The sampling trace devices are used by peripheral equipment.

High-Speed Ring Counter		
D 8099	Up-operation high-speed ring counter of 0 to 32,767 (in 0.1ms units, 16-bit)*2	M8099
[D]8100	Not used	-

*2. 0.1ms high-speed ring counter D8099 will operate after M8099 turns ON.

Memory Information														
[D]8101 PLC type and system version	<table border="1"> <tr> <td>1</td> <td>6</td> <td>2</td> <td>2</td> <td>0</td> <td>BCD converted value</td> </tr> <tr> <td colspan="2">↑ FX3U/ FX3UC</td> <td colspan="3">↑ Version 2.20</td> <td></td> </tr> </table>	1	6	2	2	0	BCD converted value	↑ FX3U/ FX3UC		↑ Version 2.20				-
1	6	2	2	0	BCD converted value									
↑ FX3U/ FX3UC		↑ Version 2.20												
[D]8102	2.....2K steps 4.....4K steps 8.....8K steps 16....16K steps 64....64K steps	-												
[D]8103	Not used	-												
[D]8104														
[D]8105														
[D]8106														
[D]8107	Number of registered device comments	M8107												
[D]8108	Number of special function units/blocks connected	-												

Number and name	Content of register	Corresponding special device
Output Refresh Error		
[D]8109	Y number where output refresh error occurs	M8109
[D]8110 to [D]8119	Not used	-
RS (FNC 80) and Computer Link [ch1]		
D 8120*3	RS (FNC 80) instruction and computer link [ch1] Communication format setting	-
D 8121*3	Computer link [ch1] Station number setting	-
[D]8122*4	RS (FNC 80) instruction: Remaining points of transmit data	M8122
[D]8123*4	RS (FNC 80) instruction: Monitoring receive data points	M8123
D 8124	RS (FNC 80) instruction: Header <Default: STX>	-
D 8125	RS (FNC 80) instruction: Terminator <Default: ETX>	-
[D]8126	Not used	-
D 8127	Computer link [ch1] Specification of on-demand head device register	M8126 to M8129
D 8128	Computer link [ch1] Specification of on-demand data length register	
D 8129*3	RS (FNC 80) instruction, computer link [ch1] Time-out time setting	

*3. Latched (battery backed) device. For details, refer to the programming manual.

*4. Cleared when PLC switches from RUN to STOP.

Number and name	Content of register	Corresponding special device
High-Speed Counter Comparison, High-Speed Table, and Positioning		
[D]8130	HSZ (FNC 55) instruction: High-speed comparison table counter	M8130
[D]8131	HSZ (FNC 55) and PLSY (FNC 57) instructions: Speed pattern table counter	M8132
[D]8132	Lower HSZ (FNC 55) and PLSY (FNC 57) instructions: Speed pattern frequency	M8132
[D]8133		
[D]8134	Lower HSZ (FNC 55) and PLSY (FNC 57) instructions: Number of target pulses for speed pattern	M8132
[D]8135		
D 8136	Lower PLSY (FNC 57), PLSR (FNC 59) instructions: Accumulated total number of pulses output to Y000 and Y001	-
D 8137		
[D]8138	HSCT (FNC280) instruction: Table count	D8138
[D]8139	HSCS (FNC 53), HSCR (FNC 54), HSZ (FNC 55), and HSCT (FNC280) instructions: Number of instructions being executed	D8139
D 8140	Lower Accumulated number of pulses output to Y000 for PLSY (FNC 57) and PLSR (FNC 59) instructions	-
D 8141		
D 8142	Lower Accumulated number of pulses output to Y001 for PLSY (FNC 57) and PLSR (FNC 59) instructions	-
D 8143		
[D]8144	Not used	-
D 8145		-
D 8146		-
D 8147		-
D 8148		-
[D]8149		-
Inverter Communication Function		
D 8150 ^{*1}	Response wait time of inverter communication [ch1]	-
[D]8151	Step number of instruction during inverter communication [ch1] Default: -1	M8151
[D]8152 ^{*2}	Error code for inverter communication [ch1]	M8152
[D]8153 ^{*2}	Inverter communication error step number latched [ch1] Default: -1	M8153
[D]8154 ^{*2}	Parameter number when error occurs during IVBWR (FNC274) instruction [ch1] Default: -1	M8154

Number and name	Content of register	Corresponding special device
D 8155 ^{*1}	Response wait time of inverter communication [ch2]	-
[D]8156	Step number of instruction during inverter communication [ch2] Default: -1	M8156
[D]8157 ^{*2}	Error code for inverter communication [ch2]	M8157
[D]8158 ^{*2}	Inverter communication error step number latched [ch2] Default: -1	M8158
[D]8159 ^{*2}	Parameter number when error occurs during IVBWR (FNC274) instruction [ch2] Default: -1	M8159

*1. Cleared when PLC power supply is turned from OFF to ON.

*2. Cleared when PLC switches from STOP to RUN.

Advanced Function		
[D]8160	Not used	-
[D]8161		-
[D]8162		-
[D]8163		-
D 8164		-
[D]8165		-
[D]8166 ^{*3}		Special block error condition
[D]8167	Not used	-
[D]8168		-
[D]8169	Access restriction status ^{*4}	-

*3. Supported in Ver. 3.00 or later.

For details on the special block error condition, refer to Subsection 14.6.4 Error Code List and Action.

*4. Access restriction status

Present value	Access restriction status	Program		Monitoring	Present value change
		Read	Write		
H**00 ^{*6}	2nd keyword is not set.	✓ ^{*5}	✓ ^{*5}	✓ ^{*5}	✓ ^{*5}
H**10 ^{*6}	Write protection	✓	-	✓	✓
H**11 ^{*6}	Read / write protection	-	-	✓	✓
H**12 ^{*6}	All online operation protection	-	-	-	-
H**20 ^{*6}	Keyword cancel	✓	✓	✓	✓

*5. The accessibility is restricted depending on the keyword setting status.

*6. "****" indicates areas used by the system.

Number and name	Content of register	Corresponding special device
N:N Network (setting)		
[D]8170	Not used	-
[D]8171		-
[D]8172		-
[D]8173	Station number	-
[D]8174	Total number of slave stations	-
[D]8175	Refresh range	-
D 8176	Station number setting	M8038
D 8177	Total slave station number setting	
D 8178	Refresh range setting	
D 8179	Retry count setting	
D 8180	Comms time-out setting	-
[D]8181	Not used	-
Index Register Z1 to Z7 and V1 to V7		
[D]8182	Value of Z1 register	-
[D]8183	Value of V1 register	-
[D]8184	Value of Z2 register	-
[D]8185	Value of V2 register	-
[D]8186	Value of Z3 register	-
[D]8187	Value of V3 register	-
[D]8188	Value of Z4 register	-
[D]8189	Value of V4 register	-
[D]8190	Value of Z5 register	-
[D]8191	Value of V5 register	-
[D]8192	Value of Z6 register	-
[D]8193	Value of V6 register	-
[D]8194	Value of Z7 register	-
[D]8195	Value of V7 register	-
[D]8196	Not used	-
[D]8197		-
[D]8198		-
[D]8199		-

Number and name	Content of register	Corresponding special device
N:N Network (monitoring)		
[D]8200	Not used	-
[D]8201	Current link scan time	-
[D]8202	Maximum link scan time	-
[D]8203	Number of communication error at master station	M8183 to M8191
[D]8204	Number of communication error at slave station No.1	
[D]8205	Number of communication error at slave station No.2	
[D]8206	Number of communication error at slave station No.3	
[D]8207	Number of communication error at slave station No.4	
[D]8208	Number of communication error at slave station No.5	
[D]8209	Number of communication error at slave station No.6	
[D]8210	Number of communication error at slave station No.7	
[D]8211	Code of communication error at master station	
[D]8212	Code of communication error at slave station No.1	
[D]8213	Code of communication error at slave station No.2	
[D]8214	Code of communication error at slave station No.3	
[D]8215	Code of communication error at slave station No.4	
[D]8216	Code of communication error at slave station No.5	
[D]8217	Code of communication error at slave station No.6	
[D]8218	Code of communication error at slave station No.7	
[D]8219 to [D]8259	Not used	-
Analog Special Adapter		
D 8260 to D 8269	1st special adapter*1	
D 8270 to D 8279	2nd special adapter*1	
D 8280 to D 8289	3rd special adapter*1	
D 8290 to D 8299	4th special adapter*1	

*1. The number of connected analog special adapters is counted from the main unit side.

21

Memory Cassette

22

Battery

A

Special Devices (M8000-, D8000-)

B

Instruction List

C

Character-code

D

Discontinued models

E

Precautions for battery transportation

F

Handling of batteries in EU member states

Number and name	Content of register	Corresponding special device
Display Module Function FX3U-7DM		
D 8300	Control device (D) for display module • Default: K-1	-
D 8301	Control device (M) for display module • Default: K-1	-
[D]8302*1	Language display setting • Japanese: K0 • English: Other than K0	-
[D]8303	LCD contrast setting value • Default: K0	-
[D]8304 to [D]8309	Not used	-

*1. Latch (battery backed) device

RND (FNC184)			
[D]8310	Lower	RND (FNC184) instruction: Data for generating random number • Default: K1	-
[D]8311	Upper		
Syntax, Circuit, Operation, or Unconnected I/O Designation Error Step Number			
D 8312	Lower	Operation error step number latched (32-bit)	M8068
D 8313	Upper		
[D]8314*2	Lower	Error step number of M8065 to M8067 (32-bit)	M8065 to M8067
[D]8315*2	Upper		
[D]8316	Lower	Step number of instruction specifying an unconnected I/O number (directly or indirectly using index register)	M8316
[D]8317	Upper		
[D]8318	BFM initialization function: Error unit number		M8318
[D]8319	BFM initialization function: Error BFM number		M8318
[D]8320 to [D]8329	Not used		-

*2. Cleared when PLC switches from STOP to RUN.

Timing Clock			
[D]8330	DUTY (FNC186) instruction: Scan counting for timing clock output 1		M8330
[D]8331	DUTY (FNC186) instruction: Scan counting for timing clock output 2		M8331
[D]8332	DUTY (FNC186) instruction: Scan counting for timing clock output 3		M8332
[D]8333	DUTY (FNC186) instruction: Scan counting for timing clock output 4		M8333
[D]8334	DUTY (FNC186) instruction: Scan counting for timing clock output 5		M8334
[D]8335	Not used		-
Positioning			
D 8336	DVIT (FNC151) instruction: Specification of interrupt input		M8336
[D]8337 to [D]8339	Not used		-
D 8340	Lower	[Y000] Current value register • Default: 0	-
D 8341	Upper		
D 8342	[Y000] Bias speed Default: 0		-
D 8343	Lower	[Y000] Maximum speed • Default: 100000	-
D 8344	Upper		

Number and name	Content of register	Corresponding special device	
D 8345	[Y000] Creep speed • Default: 1000	-	
D 8346	Lower	[Y000] Zero return speed Default: 50000	-
D 8347	Upper		
D 8348	[Y000] Acceleration time • Default: 100	-	
D 8349	[Y000] Deceleration time • Default: 100	-	
D 8350	Lower	[Y001] Current value register • Default: 0	-
D 8351	Upper		
D 8352	[Y001] Bias speed Default: 0		-
D 8353	Lower	[Y001] Maximum speed • Default: 100000	-
D 8354	Upper		
D 8355	[Y001] Creep speed • Default: 1000	-	
D 8356	Lower	[Y001] Zero return speed • Default: 50000	-
D 8357	Upper		
D 8358	[Y001] Acceleration time • Default: 100	-	
D 8359	[Y001] Deceleration time • Default: 100	-	
D 8360	Lower	[Y002] Current value register • Default: 0	-
D 8361	Upper		
D 8362	[Y002] Bias speed Default: 0		-
D 8363	Lower	[Y002] Maximum speed • Default: 100000	-
D 8364	Upper		
D 8365	[Y002] Creep speed • Default: 1000	-	
D 8366	Lower	[Y002] Zero return speed • Default: 50000	-
D 8367	Upper		
D 8368	[Y002] Acceleration time • Default: 100	-	
D 8369	[Y002] Deceleration time • Default: 100	-	
D 8370*3	Lower	[Y003] Current value register • Default: 0	-
D 8371*3	Upper		
D 8372*3	[Y003] Bias speed Default: 0		-
D 8373*3	Lower	[Y003] Maximum speed • Default: 100000	-
D 8374*3	Upper		
D 8375*3	[Y003] Creep speed Default: 1000		-
D 8376*3	Lower	[Y003] Zero return speed • Default: 50000	-
D 8377*3	Upper		
D 8378*3	[Y003] Acceleration time • Default: 100	-	
D 8379*3	[Y003] Deceleration time • Default: 100	-	
[D]8380 to [D]8392	Not used		-

*3. Available only when two FX3U-2HSY-ADP adapters are connected to an PLC.

Number and name	Content of register		Corresponding special device
Interrupt Program			
D 8393	Delay time		M8393
[D]8394	Not used		-
[D]8395*1	Symbolic Information, Block password status*2		-
[D]8396	Not used		-
[D]8397			-
Ring Counter			
D 8398	Lower	Up-operation ring counter of 0 to 2,147,483,647 (in 1ms units, 32-bit)*4	M8398
D 8399	Upper		

*1. Supported in Ver. 3.00 or later.

*2. Symbolic information storage status and execution program protection status using the block password.

Present value	Symbolic information storage	Protection of execution program
H**00*3	None	None
H**01*3	None	Provided
H**10*3	Provided	None
H**11*3	Provided	Provided

3. "" indicates areas used by the system.

*4. 1ms ring counter (D8399, D8398) will operate after M8398 turns ON.

RS2 (FNC 87) [ch1]		
D 8400	RS2 (FNC 87) [ch1] Communication format setting	-
[D]8401	Not used	-
[D]8402*5	RS2 (FNC 87) [ch1] Remaining points of transmit data	M8402
[D]8403*5	RS2 (FNC 87) [ch1] Monitoring receive data points	M8403
[D]8404	Not used	-
[D]8405	Communication parameter display [ch1]	-
[D]8406	Not used	-
[D]8407		-
[D]8408		-
D 8409	RS2 (FNC 87) [ch1] Time-out time setting	-
D 8410	RS2 (FNC 87) [ch1] Header 1 and 2 <Default: STX>	-
D 8411	RS2 (FNC 87) [ch1] Header 3 and 4	-
D 8412	RS2 (FNC 87) [ch1] Terminator 1 and 2 <Default: ETX>	-
D 8413	RS2 (FNC 87) [ch1] Terminator 3 and 4	-
[D]8414	RS2 (FNC 87) [ch1] Receive sum (received data)	-
[D]8415	RS2 (FNC 87) [ch1] Receive sum (calculated result)	-
[D]8416	RS2 (FNC 87) [ch1] Send sum	-
[D]8417	Not used	-
[D]8418		-
[D]8419		Operation mode display [ch1]

*5. Cleared when PLC switches from RUN to STOP.

Number and name	Content of register		Corresponding special device
RS2 (FNC 87) [ch2] and Computer Link [ch2]			
D 8420	RS2 (FNC 87) [ch2] Communication format setting		-
D 8421	Computer link [ch2] Station number setting		-
[D]8422*6	RS2 (FNC 87) [ch2]	Remaining points of transmit data	M8422
[D]8423*6	RS2 (FNC 87) [ch2]	Monitoring receive data points	M8423
[D]8424	Not used		-
[D]8425	Communication parameter display [ch2]		-
[D]8426	Not used		-
D 8427	Computer link [ch2]	Specification of on-demand head device register	M8426 to M8429
D 8428	Computer link [ch2]	Specification of on-demand data length register	
D 8429	RS2 (FNC 87) [ch2], computer link [ch2]	Time-out time setting	
D 8430	RS2 (FNC 87) [ch2]	Header 1 and 2 <Default: STX>	-
D 8431	RS2 (FNC 87) [ch2]	Header 3 and 4	-
D 8432	RS2 (FNC 87) [ch2]	Terminator 1 and 2 <Default: ETX>	-
D 8433	RS2 (FNC 87) [ch2]	Terminator 3 and 4	-
[D]8434	RS2 (FNC 87) [ch2]	Receive sum (received data)	-
[D]8435	RS2 (FNC 87) [ch2]	Receive sum (calculated result)	-
[D]8436	RS2 (FNC 87) [ch2]	Send sum	-
[D]8437	Not used		-

*6. Cleared when PLC switches from RUN to STOP.

21

Memory Cassette

22

Battery

A

Special Devices (M8000-, D8000-)

B

Instruction List

C

Character-code

D

Discontinued models

E

Precautions for battery transportation

F

Handling of batteries in EU member states

Number and name	Content of register		Corresponding special device
FX3U-CF-ADP [ch1]			
[D]8402 ^{*1*2}	Lower	Step number of executing CF-ADP instruction	-
[D]8403 ^{*1*2}	Upper		
[D]8404 to [D]8405	Not used		-
[D]8406 ^{*1}	CF-ADP status		-
[D]8407	Not used		-
[D]8408 ^{*1}	CF-ADP version		-
[D]8409 to [D]8413	Not used		-
[D]8414 ^{*1*2}	Lower	Error step number of M8418	-
[D]8415 ^{*1*2}	Upper		
[D]8416	Not used		-
[D]8417 ^{*1*2}	Error code in detail for CF-ADP instructions		-
[D]8418 ^{*1*2}	Error code for CF-ADP instructions		-
[D]8419 ^{*1}	Operation mode display		-

*1. Supported in Ver. 2.61 or later.

*2. Cleared when the PLC mode is changed from STOP to RUN.

FX3U-CF-ADP [ch2]			
[D]8422 ^{*3*4}	Lower	Step number of executing CF-ADP instruction	-
[D]8423 ^{*3*4}	Upper		
[D]8424 to [D]8425	Not used		-
[D]8426 ^{*3}	CF-ADP status		-
[D]8427	Not used		-
[D]8428 ^{*3}	CF-ADP version		-
[D]8429 to [D]8433	Not used		-
[D]8434 ^{*3*4}	Lower	Error step number of M8438	-
[D]8435 ^{*3*4}	Upper		
[D]8436	Not used		-
[D]8437 ^{*3*4}	Error code in detail for CF-ADP instructions		-
[D]8438 ^{*3*4}	Error code for CF-ADP instructions		-
[D]8439 ^{*3}	Operation mode display		-

*3. Supported in Ver. 2.61 or later.

*4. Cleared when the PLC mode is changed from STOP to RUN.

Number and name	Content of register		Corresponding special device
Error Detection			
[D]8438 ^{*5}	Error code for serial communication error 2 [ch2]		M8438
RS2 (FNC 87) [ch2] and Computer Link [ch2]			
[D]8439	Operation mode display [ch2]		-
Error Detection			
[D]8440 to [D]8448	Not used		-
[D]8449	Special block error code		M8449
[D]8450 to [D]8459	Not used		-
Positioning [FX3U and FX3UC PLCs]			
[D]8460 to [D]8463	Not used		-
D 8464	DSZR (FNC150) and ZRN (FNC156) instructions: [Y000] Clear signal device specification		M8464
D 8465	DSZR (FNC150) and ZRN (FNC156) instructions: [Y001] Clear signal device specification		M8465
D 8466	DSZR (FNC150) and ZRN (FNC156) instructions: [Y002] Clear signal device specification		M8466
D 8467 ^{*6}	DSZR (FNC150) and ZRN (FNC156) instructions: [Y003] Clear signal device specification		M8467
Error Detection			
[D]8468 to [D]8488	Not used		-
[D]8489 ^{*7}	Error code for special parameter error		M8489
[D]8490 to [D]8511	Not used		-

*5. Cleared when PLC power supply is turned from OFF to ON.

*6. Available only when two FX3U-2HSY-ADP adapters are connected to an PLC.

*7. Supported in Ver. 3.10 or later.

Appendix A-3 Analog special adapters [M8260 to M8299 and D8260 to D8299]

When analog special adapters are connected, operations and functions are assigned to the devices shown in the tables below according to the number of connected analog special adapters.
Devices which cannot be written are shaded in the "Operation and function" columns.

→ For details, refer to the manual of each product.

Appendix A-3-1 Special auxiliary relays (M8260 to M8299)

Number	Operation and function		
	FX3U-4AD-ADP	FX3U-4DA-ADP	FX3U-3A-ADP
Applicable version	From first version	From first version	Ver. 2.61 or later
1st analog special adapter			
M 8260	Input mode switching Ch1	Output mode switching Ch1	Input mode switching Ch1
M 8261	Input mode switching Ch2	Output mode switching Ch2	Input mode switching Ch2
M 8262	Input mode switching Ch3	Output mode switching Ch3	Output mode switching
M 8263	Input mode switching Ch4	Output mode switching Ch4	Not used
M 8264	Not used	Output hold mode cancel Ch1	Not used
M 8265	Not used	Output hold mode cancel Ch2	Not used
M 8266	Not used	Output hold mode cancel Ch3	Output hold mode cancel
M 8267	Not used	Output hold mode cancel Ch4	Sets whether or not input channel 1 is used.
M 8268	Not used	Not used	Sets whether or not input channel 2 is used.
M 8269	Not used	Not used	Sets whether or not output channel is used.
2nd analog special adapter			
M 8270	Input mode switching Ch1	Output mode switching Ch1	Input mode switching Ch1
M 8271	Input mode switching Ch2	Output mode switching Ch2	Input mode switching Ch2
M 8272	Input mode switching Ch3	Output mode switching Ch3	Output mode switching
M 8273	Input mode switching Ch4	Output mode switching Ch4	Not used
M 8274	Not used	Output hold mode cancel Ch1	Not used
M 8275	Not used	Output hold mode cancel Ch2	Not used
M 8276	Not used	Output hold mode cancel Ch3	Output hold mode cancel
M 8277	Not used	Output hold mode cancel Ch4	Sets whether or not input channel 1 is used.
M 8278	Not used	Not used	Sets whether or not input channel 2 is used.
M 8279	Not used	Not used	Sets whether or not output channel is used.
3rd analog special adapter			
M 8280	Input mode switching Ch1	Output mode switching Ch1	Input mode switching Ch1
M 8281	Input mode switching Ch2	Output mode switching Ch2	Input mode switching Ch2
M 8282	Input mode switching Ch3	Output mode switching Ch3	Output mode switching
M 8283	Input mode switching Ch4	Output mode switching Ch4	Not used
M 8284	Not used	Output hold mode cancel Ch1	Not used
M 8285	Not used	Output hold mode cancel Ch2	Not used
M 8286	Not used	Output hold mode cancel Ch3	Output hold mode cancel
M 8287	Not used	Output hold mode cancel Ch4	Sets whether or not input channel 1 is used.
M 8288	Not used	Not used	Sets whether or not input channel 2 is used.
M 8289	Not used	Not used	Sets whether or not output channel is used.
4th analog special adapter			
M 8290	Input mode switching Ch1	Output mode switching Ch1	Input mode switching Ch1
M 8291	Input mode switching Ch2	Output mode switching Ch2	Input mode switching Ch2
M 8292	Input mode switching Ch3	Output mode switching Ch3	Output mode switching
M 8293	Input mode switching Ch4	Output mode switching Ch4	Not used
M 8294	Not used	Output hold mode cancel Ch1	Not used
M 8295	Not used	Output hold mode cancel Ch2	Not used
M 8296	Not used	Output hold mode cancel Ch3	Output hold mode cancel
M 8297	Not used	Output hold mode cancel Ch4	Sets whether or not input channel 1 is used.
M 8298	Not used	Not used	Sets whether or not input channel 2 is used.
M 8299	Not used	Not used	Sets whether or not output channel is used.

Number	Operation and function		
	FX3U-4AD-PT(W)-ADP	FX3U-4AD-TC-ADP	FX3U-4AD-PNK-ADP
Applicable version	From first version	From first version	From first version
1st analog special adapter			
M 8260	Temperature unit selection	Temperature unit selection	Temperature unit selection
M 8261	Not used	Type-K/-J switching	Input sensor selection
M 8262	Not used	Not used	Not used
M 8263	Not used	Not used	Not used
M 8264	Not used	Not used	Not used
M 8265	Not used	Not used	Not used
M 8266	Not used	Not used	Not used
M 8267	Not used	Not used	Not used
M 8268	Not used	Not used	Not used
M 8269	Not used	Not used	Not used
2nd analog special adapter			
M 8270	Temperature unit selection	Temperature unit selection	Temperature unit selection
M 8271	Not used	Type-K/-J switching	Input sensor selection
M 8272	Not used	Not used	Not used
M 8273	Not used	Not used	Not used
M 8274	Not used	Not used	Not used
M 8275	Not used	Not used	Not used
M 8276	Not used	Not used	Not used
M 8277	Not used	Not used	Not used
M 8278	Not used	Not used	Not used
M 8279	Not used	Not used	Not used
3rd analog special adapter			
M 8280	Temperature unit selection	Temperature unit selection	Temperature unit selection
M 8281	Not used	Type-K/-J switching	Input sensor selection
M 8282	Not used	Not used	Not used
M 8283	Not used	Not used	Not used
M 8284	Not used	Not used	Not used
M 8285	Not used	Not used	Not used
M 8286	Not used	Not used	Not used
M 8287	Not used	Not used	Not used
M 8288	Not used	Not used	Not used
M 8289	Not used	Not used	Not used
4th analog special adapter			
M 8290	Temperature unit selection	Temperature unit selection	Temperature unit selection
M 8291	Not used	Type-K/-J switching	Input sensor selection
M 8292	Not used	Not used	Not used
M 8293	Not used	Not used	Not used
M 8294	Not used	Not used	Not used
M 8295	Not used	Not used	Not used
M 8296	Not used	Not used	Not used
M 8297	Not used	Not used	Not used
M 8298	Not used	Not used	Not used
M 8299	Not used	Not used	Not used

Appendix A-3-2 Special data registers (D8260 to D8299)

Number	Operation and function		
	FX3U-4AD-ADP	FX3U-4DA-ADP	FX3U-3A-ADP
Applicable version	From first version	From first version	Ver. 2.61 or later
1st analog special adapter			
D 8260	Input data Ch1	Output data Ch1	Input data Ch1
D 8261	Input data Ch2	Output data Ch2	Input data Ch2
D 8262	Input data Ch3	Output data Ch3	Output data
D 8263	Input data Ch4	Output data Ch4	Not used
D 8264	Number of averaging times for Ch1 (1 to 4095)	Not used	Number of averaging times for Ch1 (1 to 4095)
D 8265	Number of averaging times for Ch2 (1 to 4095)	Not used	Number of averaging times for Ch2 (1 to 4095)
D 8266	Number of averaging times for Ch3 (1 to 4095)	Not used	Not used
D 8267	Number of averaging times for Ch4 (1 to 4095)	Not used	Not used
D 8268	Error status	Error status	Error status
D 8269	Model code: K1	Model code: K2	Model code: K50
2nd analog special adapter			
D 8270	Input data Ch1	Output data Ch1	Input data Ch1
D 8271	Input data Ch2	Output data Ch2	Input data Ch2
D 8272	Input data Ch3	Output data Ch3	Output data
D 8273	Input data Ch4	Output data Ch4	Not used
D 8274	Number of averaging times for Ch1 (1 to 4095)	Not used	Number of averaging times for Ch1 (1 to 4095)
D 8275	Number of averaging times for Ch2 (1 to 4095)	Not used	Number of averaging times for Ch2 (1 to 4095)
D 8276	Number of averaging times for Ch3 (1 to 4095)	Not used	Not used
D 8277	Number of averaging times for Ch4 (1 to 4095)	Not used	Not used
D 8278	Error status	Error status	Error status
D 8279	Model code: K1	Model code: K2	Model code: K50
3rd analog special adapter			
D 8280	Input data Ch1	Output data Ch1	Input data Ch1
D 8281	Input data Ch2	Output data Ch2	Input data Ch2
D 8282	Input data Ch3	Output data Ch3	Output data
D 8283	Input data Ch4	Output data Ch4	Not used
D 8284	Number of averaging times for Ch1 (1 to 4095)	Not used	Number of averaging times for Ch1 (1 to 4095)
D 8285	Number of averaging times for Ch2 (1 to 4095)	Not used	Number of averaging times for Ch2 (1 to 4095)
D 8286	Number of averaging times for Ch3 (1 to 4095)	Not used	Not used
D 8287	Number of averaging times for Ch4 (1 to 4095)	Not used	Not used
D 8288	Error status	Error status	Error status
D 8289	Model code: K1	Model code: K2	Model code: K50
4th analog special adapter			
D 8290	Input data Ch1	Output data Ch1	Input data Ch1
D 8291	Input data Ch2	Output data Ch2	Input data Ch2
D 8292	Input data Ch3	Output data Ch3	Output data
D 8293	Input data Ch4	Output data Ch4	Not used
D 8294	Number of averaging times for Ch1 (1 to 4095)	Not used	Number of averaging times for Ch1 (1 to 4095)
D 8295	Number of averaging times for Ch2 (1 to 4095)	Not used	Number of averaging times for Ch2 (1 to 4095)
D 8296	Number of averaging times for Ch3 (1 to 4095)	Not used	Not used
D 8297	Number of averaging times for Ch4 (1 to 4095)	Not used	Not used
D 8298	Error status	Error status	Error status
D 8299	Model code: K1	Model code: K2	Model code: K50

Number	Operation and function		
	FX3U-4AD-PT(W)ADP	FX3U-4AD-TC-ADP	FX3U-4AD-PNK-ADP
Applicable version	From first version	From first version	From first version
1st analog special adapter			
D 8260	Measured temperature Ch1	Measured temperature Ch1	Measured temperature Ch1
D 8261	Measured temperature Ch2	Measured temperature Ch2	Measured temperature Ch2
D 8262	Measured temperature Ch3	Measured temperature Ch3	Measured temperature Ch3
D 8263	Measured temperature Ch4	Measured temperature Ch4	Measured temperature Ch4
D 8264	Number of averaging times for Ch1 (1 to 4095)	Number of averaging times for Ch1 (1 to 4095)	Number of averaging times for Ch1 (1 to 4095)
D 8265	Number of averaging times for Ch2 (1 to 4095)	Number of averaging times for Ch2 (1 to 4095)	Number of averaging times for Ch2 (1 to 4095)
D 8266	Number of averaging times for Ch3 (1 to 4095)	Number of averaging times for Ch3 (1 to 4095)	Number of averaging times for Ch3 (1 to 4095)
D 8267	Number of averaging times for Ch4 (1 to 4095)	Number of averaging times for Ch4 (1 to 4095)	Number of averaging times for Ch4 (1 to 4095)
D 8268	Error status	Error status	Error status
D 8269	Model code: K20 (PT), K21 (PTW)	Model code: K10	Model code: K11
2nd analog special adapter			
D 8270	Measured temperature Ch1	Measured temperature Ch1	Measured temperature Ch1
D 8271	Measured temperature Ch2	Measured temperature Ch2	Measured temperature Ch2
D 8272	Measured temperature Ch3	Measured temperature Ch3	Measured temperature Ch3
D 8273	Measured temperature Ch4	Measured temperature Ch4	Measured temperature Ch4
D 8274	Number of averaging times for Ch1 (1 to 4095)	Number of averaging times for Ch1 (1 to 4095)	Number of averaging times for Ch1 (1 to 4095)
D 8275	Number of averaging times for Ch2 (1 to 4095)	Number of averaging times for Ch2 (1 to 4095)	Number of averaging times for Ch2 (1 to 4095)
D 8276	Number of averaging times for Ch3 (1 to 4095)	Number of averaging times for Ch3 (1 to 4095)	Number of averaging times for Ch3 (1 to 4095)
D 8277	Number of averaging times for Ch4 (1 to 4095)	Number of averaging times for Ch4 (1 to 4095)	Number of averaging times for Ch4 (1 to 4095)
D 8278	Error status	Error status	Error status
D 8279	Model code: K20 (PT), K21 (PTW)	Model code: K10	Model code: K11
3rd analog special adapter			
D 8280	Measured temperature Ch1	Measured temperature Ch1	Measured temperature Ch1
D 8281	Measured temperature Ch2	Measured temperature Ch2	Measured temperature Ch2
D 8282	Measured temperature Ch3	Measured temperature Ch3	Measured temperature Ch3
D 8283	Measured temperature Ch4	Measured temperature Ch4	Measured temperature Ch4
D 8284	Number of averaging times for Ch1 (1 to 4095)	Number of averaging times for Ch1 (1 to 4095)	Number of averaging times for Ch1 (1 to 4095)
D 8285	Number of averaging times for Ch2 (1 to 4095)	Number of averaging times for Ch2 (1 to 4095)	Number of averaging times for Ch2 (1 to 4095)
D 8286	Number of averaging times for Ch3 (1 to 4095)	Number of averaging times for Ch3 (1 to 4095)	Number of averaging times for Ch3 (1 to 4095)
D 8287	Number of averaging times for Ch4 (1 to 4095)	Number of averaging times for Ch4 (1 to 4095)	Number of averaging times for Ch4 (1 to 4095)
D 8288	Error status	Error status	Error status
D 8289	Model code: K20 (PT), K21 (PTW)	Model code: K10	Model code: K11
4th analog special adapter			
D 8290	Measured temperature Ch1	Measured temperature Ch1	Measured temperature Ch1
D 8291	Measured temperature Ch2	Measured temperature Ch2	Measured temperature Ch2
D 8292	Measured temperature Ch3	Measured temperature Ch3	Measured temperature Ch3
D 8293	Measured temperature Ch4	Measured temperature Ch4	Measured temperature Ch4
D 8294	Number of averaging times for Ch1 (1 to 4095)	Number of averaging times for Ch1 (1 to 4095)	Number of averaging times for Ch1 (1 to 4095)
D 8295	Number of averaging times for Ch2 (1 to 4095)	Number of averaging times for Ch2 (1 to 4095)	Number of averaging times for Ch2 (1 to 4095)
D 8296	Number of averaging times for Ch3 (1 to 4095)	Number of averaging times for Ch3 (1 to 4095)	Number of averaging times for Ch3 (1 to 4095)
D 8297	Number of averaging times for Ch4 (1 to 4095)	Number of averaging times for Ch4 (1 to 4095)	Number of averaging times for Ch4 (1 to 4095)
D 8298	Error status	Error status	Error status
D 8299	Model code: K20 (PT), K21 (PTW)	Model code: K10	Model code: K11

Appendix B: Instruction List

Appendix B-1 Basic Instructions

Mnemonic	Function
Contact Instruction	
LD	Initial logical operation contact type NO (normally open)
LDI	Initial logical operation contact type NC (normally closed)
LDP	Initial logical operation of Rising edge pulse
LDF	Initial logical operation of Falling/trailing edge pulse
AND	Serial connection of NO (normally open) contacts
ANI	Serial connection of NC (normally closed) contacts
ANDP	Serial connection of Rising edge pulse
ANDF	Serial connection of Falling/trailing edge pulse
OR	Parallel connection of NO (normally open) contacts
ORI	Parallel connection of NC (normally closed) contacts
ORP	Parallel connection of Rising edge pulse
ORF	Parallel connection of Falling/trailing edge pulse
Connection Instruction	
ANB	Serial connection of multiple parallel circuits
ORB	Parallel connection of multiple contact circuits
MPS	Stores the current result of the internal PLC operations
MRD	Reads the current result of the internal PLC operations
MPP	Pops (recalls and removes) the currently stored result
INV	Invert the current result of the internal PLC operations
MEP	Conversion of operation result to leading edge pulse*1
MEF	Conversion of operation result to trailing edge pulse*1

*1. Supported in Ver. 2.30 or later

Mnemonic	Function
Out Instruction	
OUT	Final logical operation type coil drive
SET	SET Bit device latch ON
RST	RESET Bit device OFF
PLS	Rising edge pulse
PLF	Falling/trailing edge pulse
Master Control Instruction	
MC	Denotes the start of a master control block
MCR	Denotes the end of a master control block
Other Instruction	
NOP	No operation or null step
End Instruction	
END	Program END, I/O refresh and Return to Step 0

Appendix B-2 Step Ladder Instructions

Mnemonic	Function
STL	Starts step ladder
RET	Completes step ladder

21
Memory
Cassette

22
Battery

A
Special Devices
(M8000-D8000)

B
Instruction List

C
Character-code

D
Discontinued
models

E
Precautions for
battery
transportation

F
Handling of
batteries in EU
member states

Appendix B-3 Applied Instructions ... in Ascending Order of FNC Number

FNC No.	Mnemonic	Function
Program Flow		
00	CJ	Conditional Jump
01	CALL	Call Subroutine
02	SRET	Subroutine Return
03	IRET	Interrupt Return
04	EI	Enable Interrupt
05	DI	Disable Interrupt
06	FEND	Main Routine Program End
07	WDT	Watchdog Timer Refresh
08	FOR	Start a FOR/NEXT Loop
09	NEXT	End a FOR/NEXT Loop
Move and Compare		
10	CMP	Compare
11	ZCP	Zone Compare
12	MOV	Move
13	SMOV	Shift Move
14	CML	Complement
15	BMOV	Block Move
16	FMOV	Fill Move
17	XCH	Exchange
18	BCD	Conversion to Binary Coded Decimal
19	BIN	Conversion to Binary
Arithmetic and Logical Operation (+, -, ×, ÷)		
20	ADD	Addition
21	SUB	Subtraction
22	MUL	Multiplication
23	DIV	Division
24	INC	Increment
25	DEC	Decrement
26	WAND	Logical Word AND
27	WOR	Logical Word OR
28	WXOR	Logical Exclusive OR
29	NEG	Negation
Rotation and Shift Operation		
30	ROR	Rotation Right
31	ROL	Rotation Left
32	RCR	Rotation Right with Carry
33	RCL	Rotation Left with Carry
34	SFTR	Bit Shift Right
35	SFTL	Bit Shift Left
36	WSFR	Word Shift Right
37	WSFL	Word Shift Left
38	SFWR	Shift Write [FIFO/FILO Control]
39	SFRD	Shift Read [FIFO Control]
Data Operation		
40	ZRST	Zone Reset

FNC No.	Mnemonic	Function
41	DECO	Decode
42	ENCO	Encode
43	SUM	Sum of Active Bits
44	BON	Check Specified Bit Status
45	MEAN	Mean
46	ANS	Timed Annunciator Set
47	ANR	Annunciator Reset
48	SQR	Square Root
49	FLT	Conversion to Floating Point
High-Speed Processing		
50	REF	Refresh
51	REFF	Refresh and Filter Adjust
52	MTR	Input Matrix
53	HSCS	High-Speed Counter Set
54	HSCR	High-Speed Counter Reset
55	HSZ	High-Speed Counter Zone Compare
56	SPD	Speed Detection
57	PLSY	Pulse Y Output
58	PWM	Pulse Width Modulation
59	PLSR	Acceleration/Deceleration Setup
Handy Instruction		
60	IST	Initial State
61	SER	Search a Data Stack
62	ABSD	Absolute Drum Sequencer
63	INCD	Incremental Drum Sequencer
64	TTMR	Teaching Timer
65	STMR	Special Timer
66	ALT	Alternate State
67	RAMP	Ramp Variable Value
68	ROTC	Rotary Table Control
69	SORT	SORT Tabulated Data
External FX I/O Device		
70	TKY	Ten Key Input
71	HKY	Hexadecimal Input
72	DSW	Digital Switch (Thumbwheel Input)
73	SEGD	Seven Segment Decoder
74	SEGL	Seven Segment With Latch
75	ARWS	Arrow Switch
76	ASC	ASCII Code Data Input
77	PR	Print (ASCII Code)
78	FROM	Read From A Special Function Block
79	TO	Write To A Special Function Block

FNC No.	Mnemonic	Function
External FX Device		
80	RS	Serial Communication
81	PRUN	Parallel Run (Octal Mode)
82	ASCI	Hexadecimal to ASCII Conversion
83	HEX	ASCII to Hexadecimal Conversion
84	CCD	Check Code
85	VRRD	Volume read *1
86	VRSC	Volume scale *1
87	RS2	Serial Communication 2
88	PID	PID Control Loop
89 to 99	–	
Data Transfer 2		
100, 101	–	
102	ZPUSH	Batch Store of Index Register
103	ZPOP	Batch POP of Index Register
104 to 109	–	
Floating Point		
110	ECMP	Floating Point Compare
111	EZCP	Floating Point Zone Compare
112	EMOV	Floating Point Move
113 to 115	–	
116	ESTR	Floating Point to Character String Conversion
117	EVAL	Character String to Floating Point Conversion
118	EBCD	Floating Point to Scientific Notation Conversion
119	EBIN	Scientific Notation to Floating Point Conversion
120	EADD	Floating Point Addition
121	ESUB	Floating Point Subtraction
122	EMUL	Floating Point Multiplication
123	EDIV	Floating Point Division
124	EXP	Floating Point Exponent
125	LOGE	Floating Point Natural Logarithm
126	LOG10	Floating Point Common Logarithm
127	ESQR	Floating Point Square Root
128	ENEG	Floating Point Negation
129	INT	Floating Point to Integer Conversion
130	SIN	Floating Point Sine
131	COS	Floating Point Cosine
132	TAN	Floating Point Tangent
133	ASIN	Floating Point Arc Sine
134	ACOS	Floating Point Arc Cosine
135	ATAN	Floating Point Arc Tangent
136	RAD	Floating Point Degree to Radian Conversion

FNC No.	Mnemonic	Function
137	DEG	Floating Point Radian to Degree Conversion
138, 139	–	
Data Operation 2		
140	WSUM	Sum of Word Data
141	WTOB	WORD to BYTE
142	BTOW	BYTE to WORD
143	UNI	4-bit Linking of Word Data
144	DIS	4-bit Grouping of Word Data
145, 146	–	
147	SWAP	Byte Swap
148	–	
149	SORT2	Sort Tabulated Data 2
Positioning Control		
150	DSZR	DOG Search Zero Return
151	DVIT	Interrupt Positioning
152	TBL	Batch Data Positioning Mode
153, 154	–	
155	ABS	Absolute Current Value Read
156	ZRN	Zero Return
157	PLSV	Variable Speed Pulse Output
158	DRVI	Drive to Increment
159	DRVA	Drive to Absolute
Real Time Clock Control		
160	TCMP	RTC Data Compare
161	TZCP	RTC Data Zone Compare
162	TADD	RTC Data Addition
163	TSUB	RTC Data Subtraction
164	HTOS	Hour to Second Conversion
165	STOH	Second to Hour Conversion
166	TRD	Read RTC data
167	TWR	Set RTC data
168	–	
169	HOUR	Hour Meter
External Device		
170	GRY	Decimal to Gray Code Conversion
171	GBIN	Gray Code to Decimal Conversion
172 to 175	–	
176	RD3A	Read form Dedicated Analog Block
177	WR3A	Write to Dedicated Analog Block
178, 179	–	
Extension Function		
180	–	

21

Memory Cassette

22

Battery

A

Special Devices (M8000-DB000)

B

Instruction List

C

Character-code

D

Discontinued models

E

Precautions for battery transportation

F

Handling of batteries in EU member states

FNC No.	Mnemonic	Function
Others		
181	–	
182	COMRD	Read Device Comment Data
183	–	
184	RND	Random Number Generation
185	–	
186	DUTY	Timing Pulse Generation
187	–	
188	CRC	Cyclic Redundancy Check
189	HCMOV	High-Speed Counter Move
Block Data Operation		
190, 191	–	
192	BK+	Block Data Addition
193	BK-	Block Data Subtraction
194	BKCMP=	Block Data Compare (S1) = (S2)
195	BKCMP>	Block Data Compare (S1) > (S2)
196	BKCMP<	Block Data Compare (S1) < (S2)
197	BKCMP<>	Block Data Compare (S1) ≠ (S2)
198	BKCMP<=	Block Data Compare (S1) ≤ (S2)
199	BKCMP>=	Block Data Compare (S1) ≥ (S2)
Character String Control		
200	STR	BIN to Character String Conversion
201	VAL	Character String to BIN Conversion
202	\$+	Link Character Strings
203	LEN	Character String Length Detection
204	RIGHT	Extracting Character String Data from the Right
205	LEFT	Extracting Character String Data from the Left
206	MIDR	Random Selection of Character Strings
207	MIDW	Random Replacement of Character Strings
208	INSTR	Character string search
209	\$MOV	Character String Transfer
Data Operation 3		
210	FDEL	Deleting Data from Tables
211	FINS	Inserting Data to Tables
212	POP	Shift Last Data Read [FILO Control]
213	SFR	Bit Shift Right with Carry
214	SFL	Bit Shift Left with Carry
215 to 219	–	

FNC No.	Mnemonic	Function
Data Comparison		
220 to 223	–	
224	LD=	Load Compare (S1) = (S2)
225	LD>	Load Compare (S1) > (S2)
226	LD<	Load Compare (S1) < (S2)
227	–	
228	LD<>	Load Compare (S1) ≠ (S2)
229	LD<=	Load Compare (S1) ≤ (S2)
230	LD>=	Load Compare (S1) ≥ (S2)
231	–	
232	AND=	AND Compare (S1) = (S2)
233	AND>	AND Compare (S1) > (S2)
234	AND<	AND Compare (S1) < (S2)
235	–	
236	AND<>	AND Compare (S1) ≠ (S2)
237	AND<=	AND Compare (S1) ≤ (S2)
238	AND>=	AND Compare (S1) ≥ (S2)
239	–	
Data Comparison		
240	OR=	OR Compare (S1) = (S2)
241	OR>	OR Compare (S1) > (S2)
242	OR<	OR Compare (S1) < (S2)
243	–	
244	OR<>	OR Compare (S1) ≠ (S2)
245	OR<=	OR Compare (S1) ≤ (S2)
246	OR>=	OR Compare (S1) ≥ (S2)
247 to 249	–	
Data Table Operation		
250 to 255	–	
256	LIMIT	Limit Control
257	BAND	Dead Band Control
258	ZONE	Zone Control
259	SCL	Scaling (Coordinate by Point Data)
260	DABIN	Decimal ASCII to BIN Conversion
261	BINDA	BIN to Decimal ASCII Conversion
262 to 268	–	
269	SCL2	Scaling 2 (Coordinate by X/Y Data)

FNC No.	Mnemonic	Function
External Device Communication (Inverter Communication)		
270	IVCK	Inverter Status Check
271	IVDR	Inverter Drive
272	IVRD	Inverter Parameter Read
273	IVWR	Inverter Parameter Write
274	IVBWR	Inverter Parameter Block Write
275	IVMC	Inverter Multi Command* ¹
276 to 277	—	
Data Transfer 3		
278	RBFM	Divided BFM Read
279	WBFM	Divided BFM Write
High-Speed Processing 2		
280	HSCT	High-Speed Counter Compare With Data Table
281 to 289	—	
Extension File Register Control		
290	LOADR	Load From ER
291	SAVER	Save to ER
292	INITR	Initialize R and ER
293	LOGR	Logging R and ER
294	RWER	Rewrite to ER
295	INITER	Initialize ER
296 to 299	—	
FX3U-CF-ADP		
300	FLCRT	File create/check* ²
301	FLDEL	File delete/CF card format* ²
302	FLWR	Data write* ²
303	FLRD	Data read* ²
304	FLCMD	FX3U-CF-ADP command* ²
305	FLSTRD	FX3U-CF-ADP status read* ²

*1. Supported in Ver. 2.70 or later.

*2. Supported in Ver. 2.61 or later.

21

Memory
Cassette

22

Battery

A

Special Devices
(M8000, D8000)

B

Instruction List

C

Character-code

D

Discontinued
models

E

Precautions for
battery
transportation

F

Handling of
batteries in EU
member states

MEMO

Appendix C: Character-code

Appendix C-1 ASCII Code Table

- ¥ (ASCII Code: 5C) symbol is displayed as " ¥ " even if the language display setting at FX3U-7DM is set to English (LANGUAGE: ENGLISH).
- The Character at ASCII Code: 7E "~" is not displayed.

1. ASCII code table (7-bit code expressed in hexadecimal)

Example . "A " becomes 41H(hexadecimal number) by ASCII code.

Hexadecimal	0	1	2	3	4	5	6	7	8	9	A	B	C	D	E	F	
0			SP	0	@	P	`	p			As for this range, the Japanese syllabary is displayed.						
1			!	1	A	Q	a	q									
2			"	2	B	R	b	r									
3			#	3	C	S	c	s									
4			\$	4	D	T	d	t									
5			%	5	E	U	e	u									
6			&	6	F	V	f	v									
7			'	7	G	W	g	w									
8			(8	H	X	h	x									
9)	9	I	Y	i	y									
A			*	:	J	Z	j	z									
B			+	;	K	[k	{									
C			,	<	L	¥	l										
D			-	=	M]	m	}									
E			.	>	N	^	n										
F			/	?	O	_	o										

2. Examples of ASCII codes

Decimal	ASCII (hexadecimal)
0	30
1	31
2	32
3	33
4	34
5	35
6	36
7	37
8	38
9	39

Alphabet	ASCII (hexadecimal)	Alphabet	ASCII (hexadecimal)
A	41	N	4E
B	42	O	4F
C	43	P	50
D	44	Q	51
E	45	R	52
F	46	S	53
G	47	T	54
H	48	U	55
I	49	V	56
J	4A	W	57
K	4B	K	58
L	4C	Y	59
M	4D	Z	5A

Symbol	ASCII (hexadecimal)
#	23
&	26
=	3D
¥	5C

MEMO

Appendix D: Discontinued models

The table below lists the discontinued MELSEC-F Series PLC models and programming tools described in this manual.

Discontinued model	Production stop date	Repair acceptance period
FX-16EYT-H-TB	August 31, 2009	Until August 31, 2016
FX-10P(-E)	June 30, 2008	Until June 30, 2015
FX-232AW	September 30, 2004	Until September 30, 2011
FX-232AWC	June 30, 2004	Until June 30, 2011

MEMO

Appendix E: Precautions for Battery Transportation

When transporting lithium batteries, follow the transportation regulations.
The batteries for the FX3U Series CPU unit are classified as shown in following table.

Appendix E-1 Regulated FX3U Series products

- 1) Included modules and batteries

Series name/product name	Used battery name	Battery type	Product supply status	Lithium Content (gram/unit)
FX3U Series main unit	FX3U-32BL	lithium metal battery	Cell	0.15

- 2) Batteries to be built in modules (spare parts and optional parts)

Product name	Battery type	Product supply status	Lithium Content (gram/unit)	Mass*1 (gram/unit)
FX3U-32BL	lithium metal battery	Cell	0.15	30

*1. The value indicates the mass with packaging.

Appendix E-2 Transport guidelines

Comply with IATA Dangerous Goods Regulations, IMDG code and the local transport regulations when transporting products listed above.
Also, consult with the shipping carrier.

MEMO

Appendix F: Handling of Batteries and Devices with Built-in Batteries in EU Member States

This section describes the precautions for disposing of waste batteries in EU member states and exporting batteries and/or devices with built-in batteries to EU member states.

Appendix F-1 Disposal precautions

In EU member states, there is a separate collection system for waste batteries. Dispose of batteries properly at the local community waste collection/recycling center. The symbol shown in following figure is printed on the batteries and packaging of batteries and devices with built-in batteries used for Mitsubishi programmable controllers.



- *1. This symbol to the left is for EU member states only. The symbol is specified in the new EU Battery Directive (2006/66/EC) Article 20 "Information for end-users" and Annex II.

The symbol to the left indicates that batteries need to be disposed of separately from other wastes.

Appendix F-2 Exportation precautions

The new EU Battery Directive (2006/66/EC) requires the following when marketing or exporting batteries and/or devices with built-in batteries to EU member states.

- To print the symbol on batteries, devices, or their packaging
 - To explain the symbol in the manuals of the products
- 1) Labelling
To market or export batteries and/or devices with built-in batteries, which have no symbol, to EU member states on September 26, 2008 or later, print the symbol shown in the figure above on the batteries, devices, or their packaging.
 - 2) Explaining the symbol in the manuals
To export devices incorporating Mitsubishi programmable controller to EU member states on September 26, 2008 or later, provide the latest manuals that include the explanation of the symbol. If no Mitsubishi manuals or any old manuals without the explanation of the symbol are provided, separately attach an explanatory note regarding the symbol to each manual of the devices.

POINT

The requirements apply to batteries and/or devices with built-in batteries manufactured before the enforcement date of the new EU Battery Directive(2006/66/EC).

Appendix F-3 Regulated FX3U Series products

- 1) Included modules and batteries

Series name/product name	Used battery name	Battery type
FX3U Series main unit	FX3U-32BL	Lithium Manganese Dioxide Battery

- 2) Batteries to be built in modules (spare parts and optional parts)

Product name	Battery type
FX3U-32BL	Lithium Manganese Dioxide Battery

MEMO

Warranty

Please confirm the following product warranty details before using this product.

1. **Gratis Warranty Term and Gratis Warranty Range**

If any faults or defects (hereinafter "Failure") found to be the responsibility of Mitsubishi occurs during use of the product within the gratis warranty term, the product shall be repaired at no cost via the sales representative or Mitsubishi Service Company. However, if repairs are required onsite at domestic or overseas location, expenses to send an engineer will be solely at the customer's discretion. Mitsubishi shall not be held responsible for any re-commissioning, maintenance, or testing on-site that involves replacement of the failed module.

[Gratis Warranty Term]

The gratis warranty term of the product shall be for one year after the date of purchase or delivery to a designated place. Note that after manufacture and shipment from Mitsubishi, the maximum distribution period shall be six (6) months, and the longest gratis warranty term after manufacturing shall be eighteen (18) months. The gratis warranty term of repair parts shall not exceed the gratis warranty term before repairs.

[Gratis Warranty Range]

- 1) The range shall be limited to normal use within the usage state, usage methods and usage environment, etc., which follow the conditions and precautions, etc., given in the instruction manual, user's manual and caution labels on the product.
- 2) Even within the gratis warranty term, repairs shall be charged for in the following cases.
 - a) Failure occurring from inappropriate storage or handling, carelessness or negligence by the user. Failure caused by the user's hardware or software design.
 - b) Failure caused by unapproved modifications, etc., to the product by the user.
 - c) When the Mitsubishi product is assembled into a user's device, Failure that could have been avoided if functions or structures, judged as necessary in the legal safety measures the user's device is subject to or as necessary by industry standards, had been provided.
 - d) Failure that could have been avoided if consumable parts (battery, backlight, fuse, etc.) designated in the instruction manual had been correctly serviced or replaced.
 - e) Relay failure or output contact failure caused by usage beyond the specified Life of contact (cycles).
 - f) Failure caused by external irresistible forces such as fires or abnormal voltages, and failure caused by force majeure such as earthquakes, lightning, wind and water damage.
 - g) Failure caused by reasons unpredictable by scientific technology standards at time of shipment from Mitsubishi.
 - h) Any other failure found not to be the responsibility of Mitsubishi or that admitted not to be so by the user.

2. **Onerous repair term after discontinuation of production**

- 1) Mitsubishi shall accept onerous product repairs for seven (7) years after production of the product is discontinued. Discontinuation of production shall be notified with Mitsubishi Technical Bulletins, etc.
- 2) Product supply (including repair parts) is not available after production is discontinued.

3. **Overseas service**

Overseas, repairs shall be accepted by Mitsubishi's local overseas FA Center. Note that the repair conditions at each FA Center may differ.

4. **Exclusion of loss in opportunity and secondary loss from warranty liability**

Regardless of the gratis warranty term, Mitsubishi shall not be liable for compensation of damages caused by any cause found not to be the responsibility of Mitsubishi, loss in opportunity, lost profits incurred to the user or third person by Failures of Mitsubishi products, special damages and secondary damages whether foreseeable or not, compensation for accidents, and compensation for damages to products other than Mitsubishi products, replacement by the user, maintenance of on-site equipment, start-up test run and other tasks.

5. **Changes in product specifications**

The specifications given in the catalogs, manuals or technical documents are subject to change without prior notice.

6. **Product application**

- 1) In using the Mitsubishi MELSEC programmable logic controller, the usage conditions shall be that the application will not lead to a major accident even if any problem or fault should occur in the programmable logic controller device, and that backup and fail-safe functions are systematically provided outside of the device for any problem or fault.
- 2) The Mitsubishi programmable logic controller has been designed and manufactured for applications in general industries, etc. Thus, applications in which the public could be affected such as in nuclear power plants and other power plants operated by respective power companies, and applications in which a special quality assurance system is required, such as for Railway companies or Public service purposes shall be excluded from the programmable logic controller applications. In addition, applications in which human life or property that could be greatly affected, such as in aircraft, medical applications, incineration and fuel devices, manned transportation, equipment for recreation and amusement, and safety devices, shall also be excluded from the programmable logic controller range of applications. However, in certain cases, some applications may be possible, providing the user consults their local Mitsubishi representative outlining the special requirements of the project, and providing that all parties concerned agree to the special circumstances, solely at the users discretion.

Revised History

Date	Revision	Description
7/2005	A	First Edition
2/2006	B	<ul style="list-style-type: none"> • The following products are added: <ul style="list-style-type: none"> - Main unit of transistor output type FX3U-16MT/ES, FX3U-16MT/ESS, FX3U-32MT/ES, FX3U-32MT/ESS, FX3U-48MT/ES, FX3U-48MT/ESS, FX3U-64MT/ES, FX3U-64MT/ESS, FX3U-80MT/ES, FX3U-80MT/ESS Contents are added to product introduction (Chapter 3), specifications, external dimensions, terminal layout (Chapter 4), examination of system configuration (Chapter 6), wiring examples for each purpose (Chapter 13), etc. - Main unit of AC power type FX3U-128MR/ES, FX3U-128MT/ES, FX3U-128MT/ESS - Main unit of DC power type FX3U-16MR/DS, FX3U-16MT/DS, FX3U-16MT/DSS FX3U-32MR/DS, FX3U-32MT/DS, FX3U-32MT/DSS FX3U-48MR/DS, FX3U-48MT/DS, FX3U-48MT/DSS FX3U-64MR/DS, FX3U-64MT/DS, FX3U-64MT/DSS FX3U-80MR/DS, FX3U-80MT/DS, FX3U-80MT/DSS Contents are added to product introduction (Chapter 3), specifications, external dimensions, terminal layout (Chapter 4), examination of system configuration (Chapter 6), installation in enclosure (Chapter 8), example of power supply wiring (Chapter 9), example of input wiring (Chapter 10), example of output wiring (Chapter 12), etc. - Input/output powered extension unit of DC power type FX2N-48ER-DS, FX2N-48ET-DSS, FX2N-48ER-D, FX2N-48ET-D Contents are added to product introduction (Chapter 3), examination of system configuration (Chapter 6), installation in enclosure (Chapter 8), example of power supply wiring (Chapter 9), input/output powered extension units (Chapter 15), etc. - 8-point type input/output extension block FX2N-8ER-ES/UL, FX2N-8ER, FX2N-8EX-ES/UL, FX2N-8EX, FX2N-8EX-UA1/UL, FX2N-8EYR-ES/UL, FX2N-8EYR, FX2N-8EYT-ESS/UL, FX2N-8EYT, FX2N-8EYT-H Contents are added to product introduction (Chapter 3), examination of system configuration (Chapter 6), input/output extension block (Chapter 16), etc. - Special function blocks FX3U-4AD, FX3U-4DA, FX3U-20SSC-H Contents are added to product introduction (Chapter 3), examination of system configuration (Chapter 6), installation in enclosure (Chapter 8), other extension devices (Chapter 18), etc. - Extension power supply unit FX3U-1PSU-5V Contents are added to product introduction (Chapter 3), examination of system configuration (Chapter 6), installation in enclosure (Chapter 8), example of power supply wiring (Chapter 9), etc. Chapter 17 added for Extension power supply unit • Ver. 2.30 is supported. <ul style="list-style-type: none"> - Two types of instructions are added (Appendix B-1). For the details of these instructions, refer to the programming manual. - Special auxiliary relays and special data registers are added (Appendix A). • Cautions on write during RUN are added (Subsection 5.2.4). • The applicability of other peripheral equipment is added (Section 5.5).
5/2006	C	<ul style="list-style-type: none"> • EN61131-2:2003 added to EMC directive and LVD directive in FX2N series.

Date	Revision	Description
3/2007	D	<ul style="list-style-type: none"> • Tightening Torque at the Time of Loading /Unloading System Terminal Block Anchoring, Notice Addition (Subsection 2.2.1, 8.5.4, 9.1.2 and 15.2.2). • Life Details Addition of Relay Output Contact (Subsection 4.4.2, 12.2.2, 14.4.3 and 20.7.5). • Caution Addition (Section 6.1) for Extension-Equipment Selection. • Caution Addition for Time of Wiring (Subsection 12.2.4 and 20.7.4) • Various Corrections and Table Additions (Subsection 14.4.2 and 22.3.1) for the Service Life of the Battery. • Notice Addition at the Time of Battery Replacement (Subsection 22.5) • Production Stop Addition (Appendix D)
6/2007	E	<ul style="list-style-type: none"> • Explanation corrections for reading the battery's year/month of manufacture.
11/2008	F	Errors are corrected.
11/2009	G	<ul style="list-style-type: none"> • The following products are added: <ul style="list-style-type: none"> - Special function blocks FX3U-64CCL Contents are added to product introduction (Chapter 3), examination of system configuration (Chapter 6), installation in enclosure (Chapter 8), other extension devices (Chapter 18), etc. - Special adapters FX3U-3A-ADP, FX3U-4AD-PTW-ADP, FX3U-4AD-PNK-ADP, FX3U-CF-ADP Contents are added to product introduction (Chapter 3), examination of system configuration (Chapter 6), installation in enclosure (Chapter 8), other extension devices (Chapter 18), etc. - Programming tool FX-30P Contents are added to programming tool applicability (Section 5.2), etc. • Ver. 2.41 is supported. <ul style="list-style-type: none"> - The baud rate "38400 bps" is supported in RS and RS2 instructions, inverter communication and computer link. • Ver. 2.61 is supported. <ul style="list-style-type: none"> - Supports FX3U-CF-ADP Six types of instructions are added (Appendix B-1) For the details of these instructions, refer to the FX3U-CF-ADP user's manual. Special auxiliary relays and special data registers are added (Appendix A) - Supports FX3U-3A-ADP Special auxiliary relays and special data registers are added (Appendix A) - Customer keyword / permanent PLC lock is supported. • Cautions on connecting peripheral equipment by way expansion board or special adapter are added (Subsection 5.2.4) • The applicability of other peripheral equipment is added (Section 5.5) • Precautions for Battery Transportation are added (Appendix E) • Handling of Batteries and Devices with Built-in Batteries in EU Member States are added (Appendix F) • Errors are corrected.
3/2010	H	<ul style="list-style-type: none"> • Explanation corrections for manufacturer's serial number and lot number. • Explanation corrections for battery's lot number.

Date	Revision	Description
9/2010	J	<ul style="list-style-type: none"> • The following products are added: <ul style="list-style-type: none"> - Main unit of triac output type FX3U-32MS/ES, FX3U-64MS/ES - Main unit of AC input type FX3U-32MR/UA1, FX3U-64MR/UA1 Contents are added to product introduction (Chapter 3), specifications, external dimensions, terminal layout (Chapter 4), examination of system configuration (Chapter 6), installation in enclosure (Chapter 8), example of power supply wiring (Chapter 9), example of input wiring (Chapter 10), example of output wiring (Chapter 12), etc. - Input/output extension block FX2N-8EYR-S-ES/UL Contents are added to product introduction (Chapter 3), FX2N-8/16E*-* (Input/Output Extension Blocks) (Chapter 16), etc. - Special function blocks FX3U-2HC, FX3U-4LC Contents are added to product introduction (Chapter 3), examination of system configuration (Chapter 6), installation in enclosure (Chapter 8), other extension devices (Chapter 18), etc. - Expansion board FX3U-8AV-BD Contents are added to product introduction (Chapter 3), examination of system configuration (Chapter 6), other extension devices (Chapter 18), etc. <ul style="list-style-type: none"> • Ver. 2.70 is supported. <ul style="list-style-type: none"> - Three types of instructions are added (Appendix B-3) For the details of these instructions, refer to the FX3G/FX3U/FX3UC Programming Manuals. - Supports connection of following analog volume expansion board. FX3U-8AV-BD - Supports the under-scale detection function of the FX3U-4AD-ADP and FX3U-3A-ADP. • GX Works2 is added. • Errors are corrected.
7/2011	K	<ul style="list-style-type: none"> • The following product is added: <ul style="list-style-type: none"> - Memory cassette FX3U-FLROM-1M Contents are added to product introduction (Chapter 3), FX3U-FLROM-16/64/64L/1M (Memory Cassette) (Chapter 21), etc. • Ver. 3.00 is supported. <ul style="list-style-type: none"> - Supports storage of symbolic information. - Support of the setting "Read-protect the execution program." for block passwords. - Special block error condition (D8166) is added. - Supports connection of following memory cassette. FX3U-FLROM-1M • Errors are corrected.
3/2012	L	<ul style="list-style-type: none"> • The following product is added: <ul style="list-style-type: none"> - Special function block FX3U-16CCL-M Contents are added to product introduction (Chapter 3), Other Extension Devices (Chapter 18), etc. • Ver. 3.10 is supported. <ul style="list-style-type: none"> - Supports parameter setting in the FX3U-16CCL-M. - Supports accessing the other station from CC-Link. - Special parameter error (M8489 and D8489) is added. Description of special auxiliary relays and special data registers is added. (Appendix A) - The error code for parameter error is added. (Subsection 14.6.4) - The error code for special block error is added. (Subsection 14.6.4) • Errors are corrected.

FX3U SERIES PROGRAMMABLE CONTROLLERS

USER'S MANUAL

Hardware Edition



HEAD OFFICE: TOKYO BUILDING, 2-7-3 MARUNOUCHI, CHIYODA-KU, TOKYO 100-8310, JAPAN
HIMEJI WORKS: 840, CHIYODA CHO, HIMEJI, JAPAN

MODEL	FX3U-HW-E
MODEL CODE	09R516