

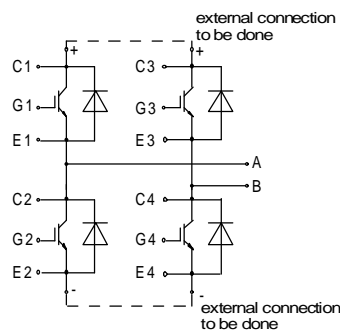

European Power-Semiconductor and Electronics Company

# Marketing Information

## F4 400 R 12 KF4

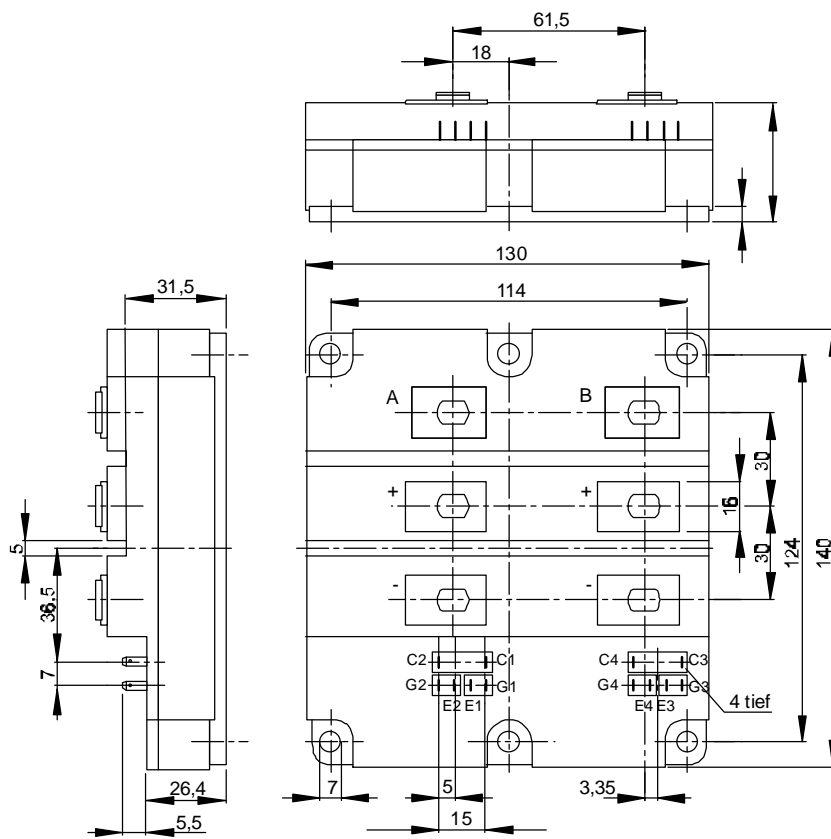

# F4 400 R 12 KF4

## Höchstzulässige Werte / Maximum rated values Elektrische Eigenschaften / Electrical properties

Kollektor-Emitter-Sperrspannung	collector-emitter voltage		$V_{CES}$	1200 V
Kollektor-Dauerleichstrom	DC-collector current		$I_C$	400 A
Periodischer Kollektor Spitzenstrom	repetitive peak collector current	$t_p = 1 \text{ ms}$	$I_{CRM}$	800 A
Gesamt-Verlustleistung	total power dissipation	$T_C = 25^\circ\text{C}$ , Transistor / Transistor	$P_{tot}$	2500 W
Gate-Emitter-Spitzenspannung	gate-emitter peak voltage		$V_{GE}$	$\pm 20 \text{ V}$
Dauerleichstrom	DC forward current		$I_F$	400 A
Periodischer Spitzenstrom	repetitive peak forw. current	$t_p = 1 \text{ ms}$	$I_{FRM}$	800 A
Isolations-Prüfspannung	insulation test voltage	RMS, $f = 50 \text{ Hz}$ , $t = 1 \text{ min}$	$V_{ISOL}$	2,5 kV

## Charakteristische Werte / Characteristic values: Transistor

				min.	typ.	max.
Kollektor-Emitter Sättigungsspannung	collector-emitter saturation voltage	$i_C = 400 \text{ A}$ , $v_{GE} = 15 \text{ V}$ , $T_{vj} = 25^\circ\text{C}$ $i_C = 400 \text{ A}$ , $v_{GE} = 15 \text{ V}$ , $T_{vj} = 125^\circ\text{C}$	$V_{CE \text{ sat}}$	-	2,7	3,2 V
Gate-Emitter Schwellenspannung	gate-emitter threshold voltage	$i_C = 16 \text{ mA}$ , $v_{CE} = v_{GE}$ , $T_{vj} = 25^\circ\text{C}$	$V_{GE(TO)}$	4,5	5,5	6,5 V
Eingangskapazität	input capacity	$f_0 = 1 \text{ MHz}$ , $T_{vj} = 25^\circ\text{C}$ , $v_{CE} = 25 \text{ V}$ , $v_{CE} = 1200 \text{ V}$ , $v_{GE} = 0 \text{ V}$ , $T_{vj} = 25^\circ\text{C}$	$C_{ies}$	-	27	- nF
Kollektor-Emitter Reststrom	collector-emitter cut-off current	$v_{CE} = 1200 \text{ V}$ , $v_{GE} = 0 \text{ V}$ , $T_{vj} = 125^\circ\text{C}$	$i_{CES}$	-	8	- mA
Gate-Emitter Reststrom	gate leakage current	$v_{CE} = 0 \text{ V}$ , $v_{GE} = 20 \text{ V}$ , $T_{vj} = 25^\circ\text{C}$	$i_{GES}$	-	-	400 nA
Emitter-Gate Reststrom	gate leakage current	$v_{CE} = 0 \text{ V}$ , $v_{EG} = 20 \text{ V}$ , $T_{vj} = 25^\circ\text{C}$	$i_{EGS}$	-	-	400 nA
Einschaltzeit (induktive Last)	turn-on time (inductive load)	$i_C = 400 \text{ A}$ , $v_{CE} = 600 \text{ V}$	$t_{on}$	-	0,7	- $\mu\text{s}$
		$v_L = \pm 15 \text{ V}$ , $R_G = 2,4 \Omega$ , $T_{vj} = 25^\circ\text{C}$		-	0,8	- $\mu\text{s}$
Speicherzeit (induktive Last)	storage time (inductive load)	$v_L = \pm 15 \text{ V}$ , $R_G = 2,4 \Omega$ , $T_{vj} = 125^\circ\text{C}$	$t_s$	-	0,9	- $\mu\text{s}$
		$i_C = 400 \text{ A}$ , $v_{CE} = 600 \text{ V}$		-	1	- $\mu\text{s}$
Fallzeit (induktive Last)	fall time (inductive load)	$v_L = \pm 15 \text{ V}$ , $R_G = 2,4 \Omega$ , $T_{vj} = 25^\circ\text{C}$	$t_f$	-	0,1	- $\mu\text{s}$
		$v_L = \pm 15 \text{ V}$ , $R_G = 2,4 \Omega$ , $T_{vj} = 125^\circ\text{C}$		-	0,15	- $\mu\text{s}$
Einschaltverlustenergie pro Puls	turn-on energy loss per pulse	$i_C = 400 \text{ A}$ , $v_{CE} = 600 \text{ V}$ , $L_S = 70 \text{ nH}$ $v_L = \pm 15 \text{ V}$ , $R_G = 2,4 \Omega$ , $T_{vj} = 125^\circ\text{C}$	$E_{on}$	-	100	- mWs
Abschaltverlustenergie pro Puls	turn-off energy loss per pulse	$i_C = 400 \text{ A}$ , $v_{CE} = 600 \text{ V}$ , $L_S = 70 \text{ nH}$ $v_L = \pm 15 \text{ V}$ , $R_G = 2,4 \Omega$ , $T_{vj} = 125^\circ\text{C}$	$E_{off}$	-	55	- mWs

## Charakteristische Werte / Characteristic values

Durchlaßspannung	forward voltage	$i_F = 400 \text{ A}$ , $v_{GE} = 0 \text{ V}$ , $T_{vj} = 25^\circ\text{C}$ $i_F = 400 \text{ A}$ , $v_{GE} = 0 \text{ V}$ , $T_{vj} = 125^\circ\text{C}$	$v_F$	-	2,2	2,7 V
Rückstromspitze	peak reverse recovery current	$i_F = 400 \text{ A}$ , $-di_F/dt = 2 \text{ kA}/\mu\text{s}$	$I_{RM}$	-	2,0	2,5 V
		$v_{RM} = 600 \text{ V}$ , $v_{EG} = 10 \text{ V}$ , $T_{vj} = 25^\circ\text{C}$ $v_{RM} = 600 \text{ V}$ , $v_{EG} = 10 \text{ V}$ , $T_{vj} = 125^\circ\text{C}$		-	125	- A
Sperrverzögerungsladung	recovered charge	$i_F = 400 \text{ A}$ , $-di_F/dt = 2 \text{ kA}/\mu\text{s}$ $v_{RM} = 600 \text{ V}$ , $v_{EG} = 10 \text{ V}$ , $T_{vj} = 25^\circ\text{C}$ $v_{RM} = 600 \text{ V}$ , $v_{EG} = 10 \text{ V}$ , $T_{vj} = 125^\circ\text{C}$	$Q_r$	-	13	- $\mu\text{As}$
				-	45	- $\mu\text{As}$

## Inversdiode / Inverse diode

## Thermische Eigenschaften / Thermal properties

Innerer Wärmewiderstand	thermal resistance, junction to case	Transistor, DC, pro Modul / per Transistor, DC, pro Zweig / per arm	$R_{thJC}$	0,013 $^\circ\text{C}/\text{W}$ 0,05 $^\circ\text{C}/\text{W}$
Übergangs-Wärmewiderstand	thermal resistance, case to heatsink	Diode, DC, pro Modul / per module Diode, DC, pro Zweig / per arm pro Modul / per module pro Zweig / per arm	$R_{thCK}$	0,021 $^\circ\text{C}/\text{W}$ 0,084 $^\circ\text{C}/\text{W}$ typ. 0,008 $^\circ\text{C}/\text{W}$ typ. 0,032 $^\circ\text{C}/\text{W}$
Höchstzul. Sperrschichttemperatur	max. junction temperature		$T_{vj \text{ max}}$	150 $^\circ\text{C}$
Betriebstemperatur	operating temperature		$T_{c \text{ op}}$	-40...+125 $^\circ\text{C}$
Lagertemperatur	storage temperature		$T_{stg}$	-40...+125 $^\circ\text{C}$

## Mechanische Eigenschaften / Mechanical properties

Innere Isolation	internal insulation			$\text{Al}_2\text{O}_3$
Anzugsdrehmoment f. mech. Befestigung	mounting torque	terminals M6 / tolerance $\pm 15\%$	M1	5 Nm
Anzugsdrehmoment f. elektr. Anschlüsse	terminal connection torque	terminals M6	M2	5...6 Nm
Gewicht	weight		G	ca. 1500 g

## Bedingung für den Kurzschlußschutz / Conditions for short-circuit protection

$t_{ig} = 10 \mu\text{s}$	$V_{CC} = 750 \text{ V}$
$v_L = \pm 15 \text{ V}$	$v_{CEM} = 900 \text{ V}$
$R_{GF} = R_{GR} = 2,4 \Omega$	$i_{CMK1} \approx 2500 \text{ A}$
$T_{vj} = 125^\circ\text{C}$	$i_{CMK2} \approx 2200 \text{ A}$

Unabhängig davon gilt bei abweichenden Bedingungen / with regard to other conditions  $v_{CEM} = V_{CES} - 15 \text{ nH} \times |di_c/dt|$

Mit dieser technischen Information werden Halbleiterbauelemente spezifiziert, jedoch keine Eigenschaften zugesichert. Sie gilt in Verbindung mit den zugehörigen Technischen Erläuterungen. This technical information specifies semiconductor devices but promises no characteristics. It is valid in combination with the belonging technical notes.



Bild / Fig. 1  
 Kollektor-Emitter-Spannung im Sättigungsbereich (typisch) /  
 Collector-emitter-voltage in saturation region (typical)  
 $V_{GE} = 15 \text{ V}$   
 -----  $T_{vj} = 25^\circ\text{C}$   
 —————  $T_{vj} = 125^\circ\text{C}$



Bild / Fig. 2  
 Kollektor-Emitter-Spannung im Sättigungsbereich (typisch) /  
 Collector-emitter-voltage in saturation region (typical)  
 $T_{vj} = 125^\circ\text{C}$

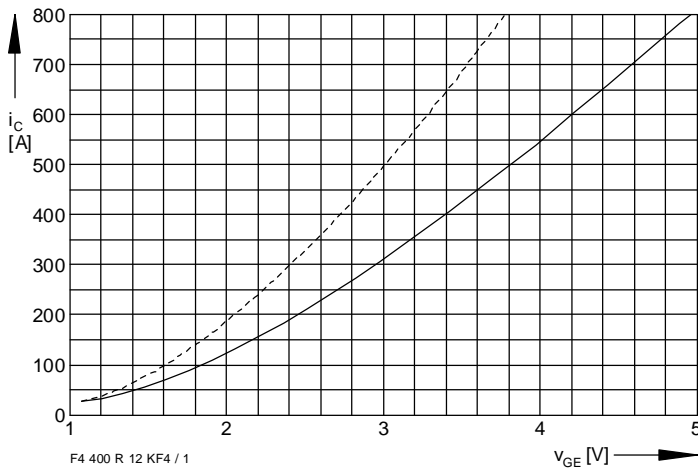

Bild / Fig. 3  
 Übertragungscharakteristik (typisch) /  
 Transfer characteristic (typical)  
 $V_{CE} = 20 \text{ V}$

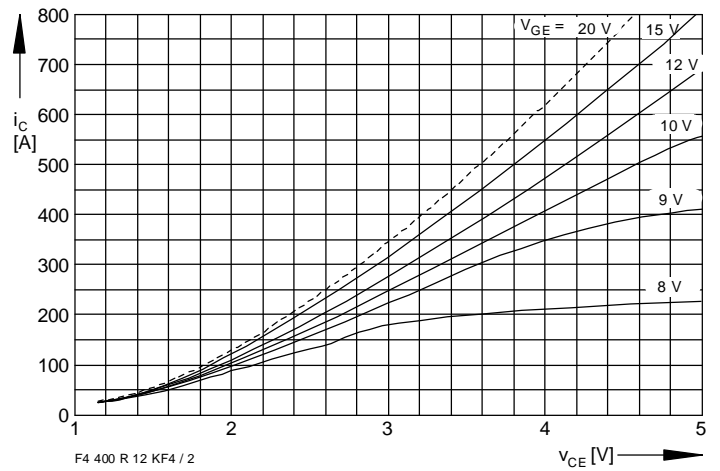

Bild / Fig. 4  
 Rückwärts-Arbeitsbereich /  
 Reverse biased safe operating area  
 $T_{vj} = 125^\circ\text{C}$   
 $V_{LF} = V_{LR} = 15 \text{ V}$   
 $R_G = 2,4 \Omega$

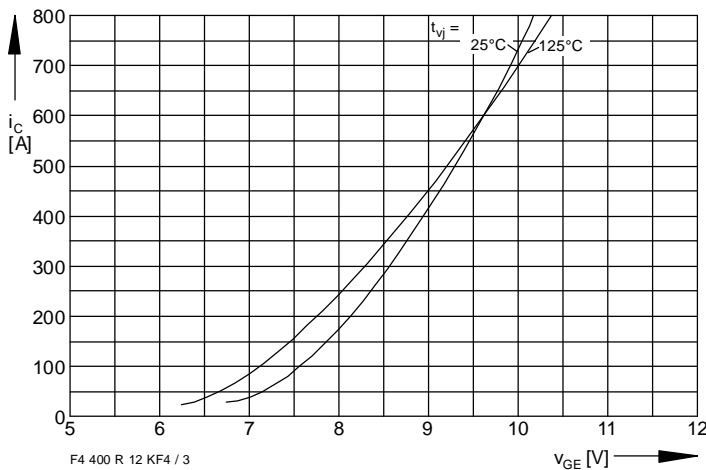

Bild / Fig. 5  
 Transienter Wärmewiderstand je Zweig (DC) /  
 Transient thermal impedance per arm (DC)

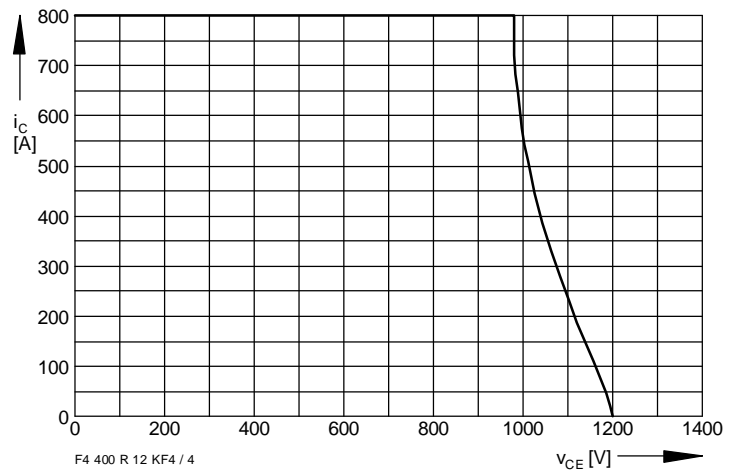
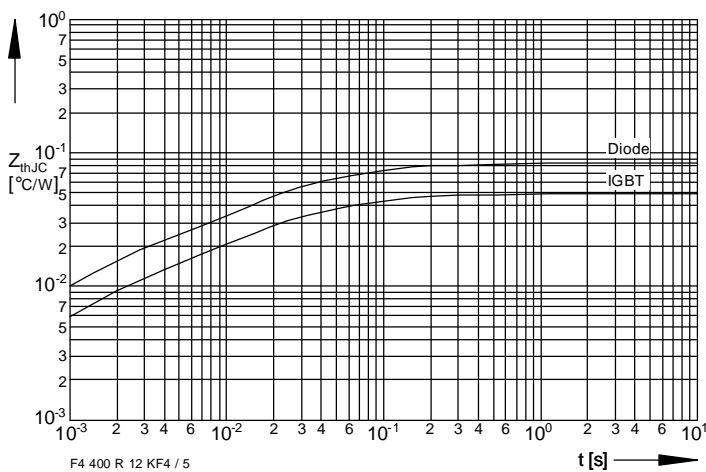
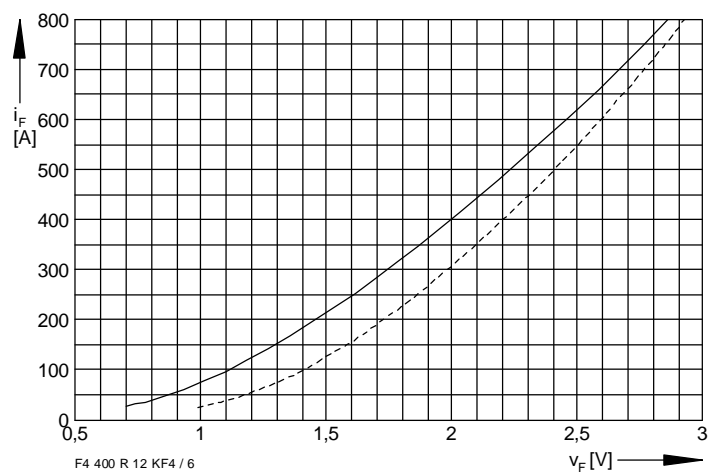

Bild / Fig. 6  
 Durchlaßkennlinien der Inversdiode (typisch) /  
 Forward characteristics of the inverse diode (typical)  
 -----  $T_{vj} = 25^\circ\text{C}$   
 —————  $T_{vj} = 125^\circ\text{C}$