



# HIGH POWER NPN POWER DARLINGTON TRANSISTORS

**D66DV5,6,7  
D66EV5,6,7**

**500-700 VOLTS  
50 AMP, 125 WATTS**

The General Electric D66DV and EV are high current power Darlington transistors. They feature collector isolation from the heat sink, and internal construction designed for stress-free operation at temperature extremes and quick connect electrical terminals. They are designed to meet UL creep, strike and isolation voltage. Major applications are for motor controls, switching power supplies, and UPS systems.

**Features:**

- High Voltage: 400-500  $V_{CEO(SUS)}$ ; 500-700  $V_{CEV}$
- High Current: 75 Amperes,  $I_C$  (Peak)
- High Gain:  $h_{FE}$  50 Minimum @ 50 Amperes,  $I_C$  ( $h_{FE} = 135$ , typical)

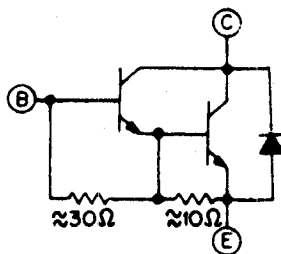

**D66DV**

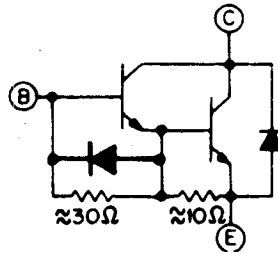

**D66EV**

**DEVICE CIRCUIT**

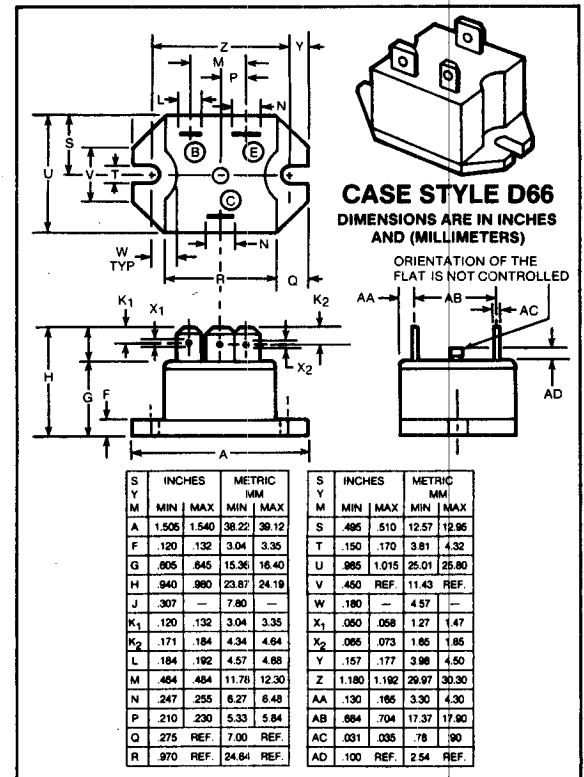

maximum ratings ( $T_C = 25^\circ C$ ) (unless otherwise noted)

RATING	SYMBOL	D66DV5/EV5	D66DV6/EV6	D66DV7/EV7	UNITS
Collector-Emitter Voltage	$V_{CEV}$	500	600	700	Volts
Collector-Emitter Voltage	$V_{CEO}$	400	450	500	Volts
Emitter Base Voltage	$V_{EBO}$	8	8	8	Volts
	D66DV D66EV	5	5	5	
Collector Current — Continuous	$I_C$	50	50	50	A
Peak (Repetitive)	$I_{CM}$	75	75	75	
Peak (Non-Repetitive)	$I_{CSM}$	125	125	125	
Base Current — Continuous	$I_B$	10	10	10	A
Peak (Non-Repetitive)	$I_{BM}$	20	20	20	
Total Power Dissipation @ $T_C = 25^\circ C$	$P_D$	125	125	125	Watts
Operating and Storage Junction Temperature Range	$T_J, T_{STG}$	-40 to +150	-40 to +150	-40 to +150	$^\circ C$
Isolation Voltage	$V_{ISOL}$	2500	2500	2500	$V_{(rms)}$

**thermal characteristics**

Thermal Resistance, Junction to Case	$R_{\theta JC}$	4	4	4	$^\circ C/W$
--------------------------------------	-----------------	---	---	---	--------------

See page 845 for mounting and handling considerations.

electrical characteristics ( $T_C = 25^\circ\text{C}$ ) (unless otherwise specified)

CHARACTERISTIC	SYMBOL	MIN	TYP	MAX	UNIT
----------------	--------	-----	-----	-----	------

off characteristics

Collector-Emitter Sustaining Voltage ( $I_C = 1\text{A}$ ) ( $V_{\text{clamp}} = V_{\text{CEO Rated}}$ )	D66DV5/EV5 D66DV6/EV6 D66DV7/EV7	$V_{\text{CEO(sus)}}$	400 450 500	— — —	— — —	Volts
Collector Cutoff Current ( $V_{\text{CE}} = \text{Rated Value}, V_{\text{BE}} = -1.5\text{V}$ )	$T_J = 25^\circ\text{C}$ $T_J = 150^\circ\text{C}$	$I_{\text{CEV}}$	— —	— —	10 2.5	mA
Emitter Cutoff Current ( $V_{\text{EB}} = 4.5\text{V}, I_C = 0$ ) ( $V_{\text{EB}} = 1.5\text{V}, I_C = 0$ )	D66DV D66EV	$I_{\text{EBO}}$	— —	— —	350 350	mA

second breakdown

Second Breakdown with Base Forward Biased	FBSOA	SEE FIGURE 23
---	-------	---------------

on characteristics

DC Current Gain ( $I_C = 75\text{A}, V_{\text{CE}} = 5\text{V}$ ) ( $I_C = 50\text{A}, V_{\text{CE}} = 5\text{V}$ ) ( $I_C = 20\text{A}, V_{\text{CE}} = 5\text{V}$ )	$h_{\text{FE}}$	25 50 100	60 135 250	— — —	—
Collector-Emitter Saturation Voltage ( $I_C = 75\text{A}, I_B = 5\text{A}$ ) ( $I_C = 50\text{A}, I_B = 4\text{A}$ ) ( $I_C = 20\text{A}, I_B = 2\text{A}$ )	$V_{\text{CE(sat)}}$	— — —	2.2 1.7 1.15	3.0 2.0 1.5	V
Base-Emitter Saturation Voltage ( $I_C = 75\text{A}, I_B = 5\text{A}$ ) ( $I_C = 50\text{A}, I_B = 4\text{A}$ ) ( $I_C = 20\text{A}, I_B = 2\text{A}$ )	$V_{\text{BE(sat)}}$	— — —	2.8 2.45 1.95	3.5 3.0 2.5	V

switching characteristics

		TYP.		MAX.				
Resistive Load			DV	EV	DV	EV		
Delay Time	$V_{\text{CC}} = 250\text{V}$	$t_d$	—	.09	.09	.5	.5	$\mu\text{s}$
Rise Time	$I_C = 50\text{A}$	$t_r$	—	.5	.5	1	1	
Storage Time	$I_{\text{B1}} = 2.5\text{A}, I_{\text{B2}} = 5\text{A}$	$t_s$	—	2.55	2	5	3	
Fall Time	$t_p = 50 \mu\text{sec}$	$t_f$	—	1.4	.64	3	1	

emitter-collector diode characteristics

Power Dissipation ( $I_{\text{B1}} = 0$ )	$P_D$	—	—	125	Watts
Forward Voltage ( $I_F = 25\text{A}$ ) ( $I_F = 50\text{A}$ ) ( $I_F = 50\text{A}, T_J = 150^\circ\text{C}$ )	$V_F$	—	1.95	3.20	Volts
	$V_F$	—	2.60	3.80	Volts
	$V_F$	—	2.30	3.50	Volts
Reverse Recovery Time ( $I_F = 50\text{A}, di/dt = 25\text{A}/\mu\text{sec}, R_{\text{B1E}} = .25\Omega$ )	$T_{\text{rr}}$	—	3.85	10.0	$\mu\text{sec}$
Forward Turn-On Time ( $I_F = 50\text{A}, di/dt = 100\text{A}/\mu\text{sec}$ )	$T_{\text{ON}}$	—	0.75	1.5	$\mu\text{sec}$
Single Cycle Surge Current (60Hz)	$I_{\text{FSM}}$	—	—	150	Amps
Thermal Resistance	$R_{\theta\text{JC}}$	—	—	1.0	$^\circ\text{C}/\text{Watt}$

# TYPICAL CHARACTERISTICS

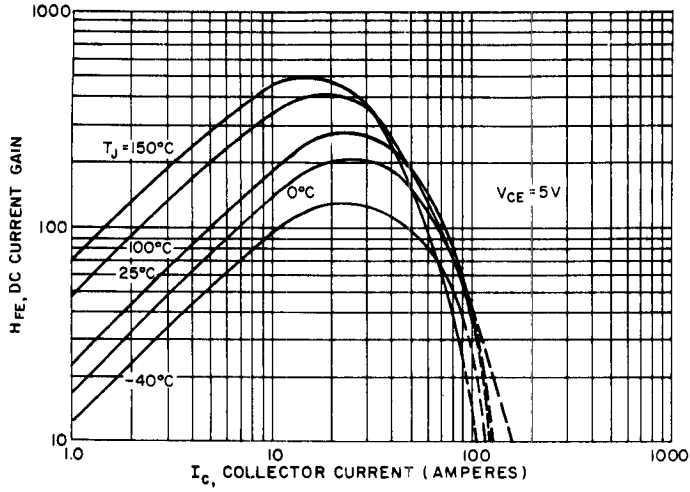

FIGURE 1. DC CURRENT GAIN ( $V_{CE} = 5V$ )

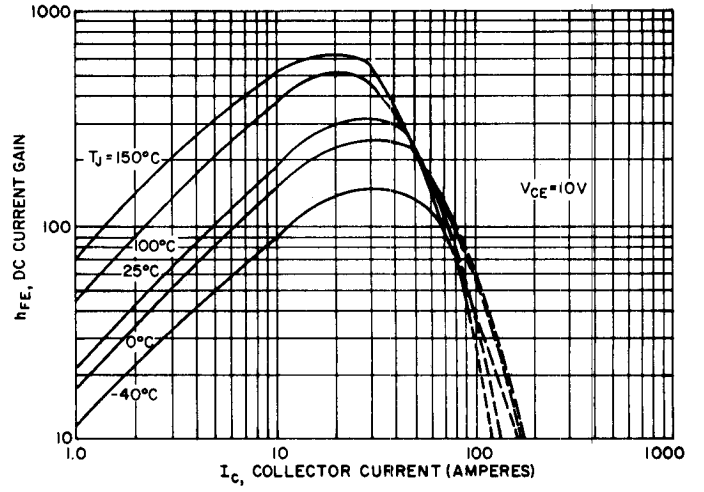

FIGURE 2. DC CURRENT GAIN ( $V_{CE} = 10V$ )

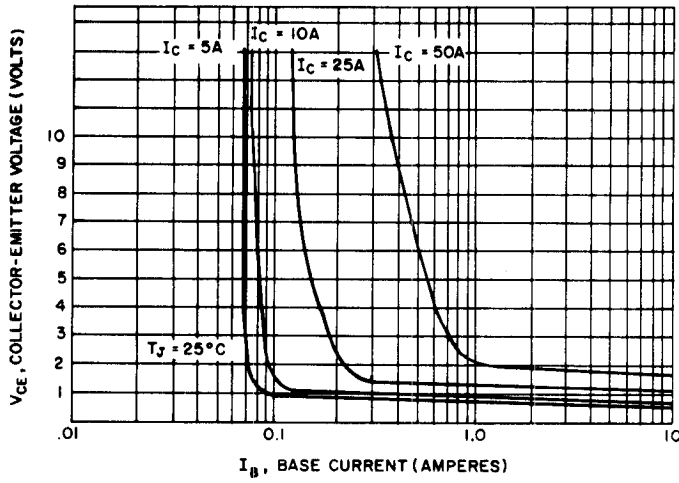

FIGURE 3. COLLECTOR SATURATION REGION

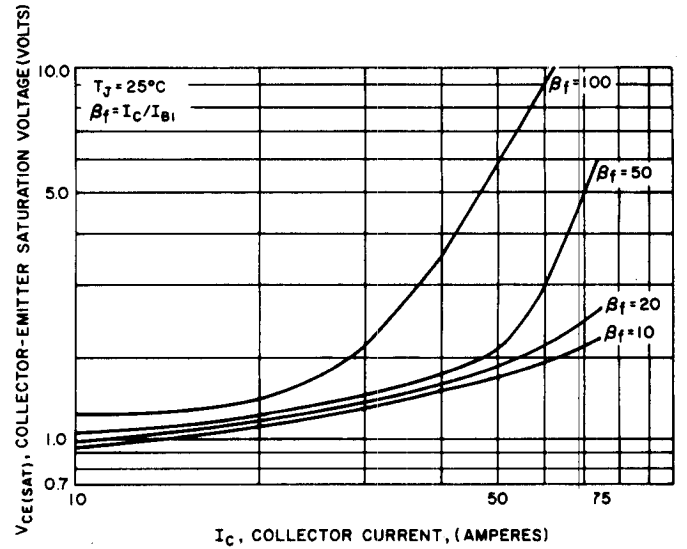

FIGURE 4.  $V_{CE} (SAT)$  VS  $I_C$ ,  $T_J = 25^\circ C$

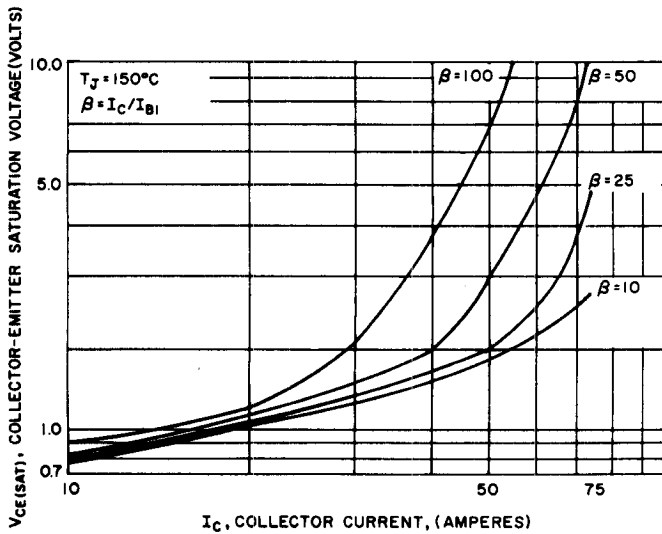

FIGURE 5.  $V_{CE} (SAT)$  VS  $I_C$ ,  $T_J = 150^\circ C$

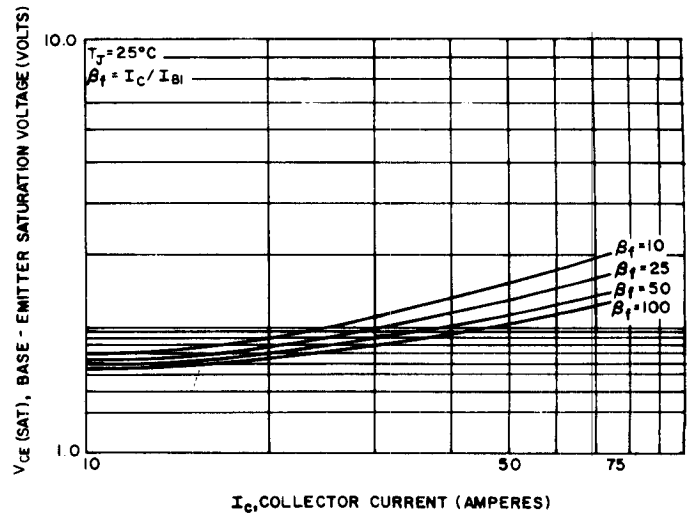

FIGURE 6.  $V_{BE} (SAT)$  VS  $I_C$ ,  $T_J = 25^\circ C$

# TYPICAL CHARACTERISTICS

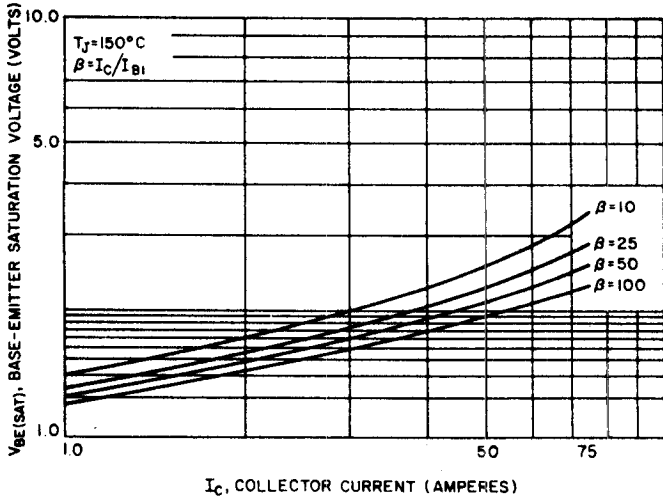

FIGURE 7.  $V_{BE(SAT)}$  VS  $I_C$ ,  $T_J = 150^\circ\text{C}$

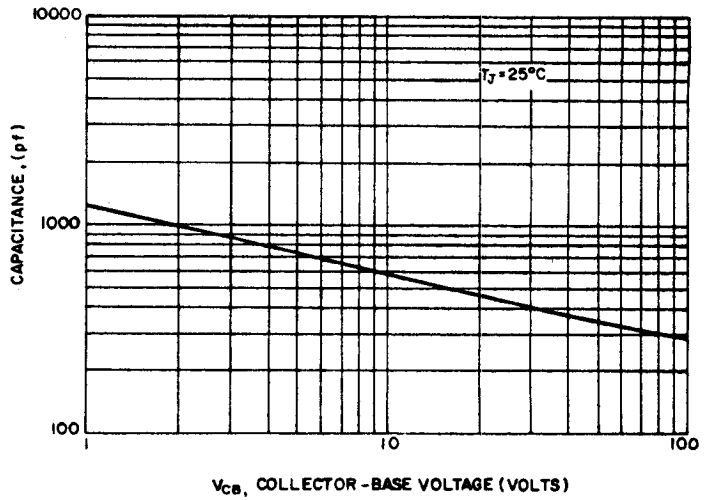

FIGURE 8. CAPACITANCE ( $C_{CB0}$ )

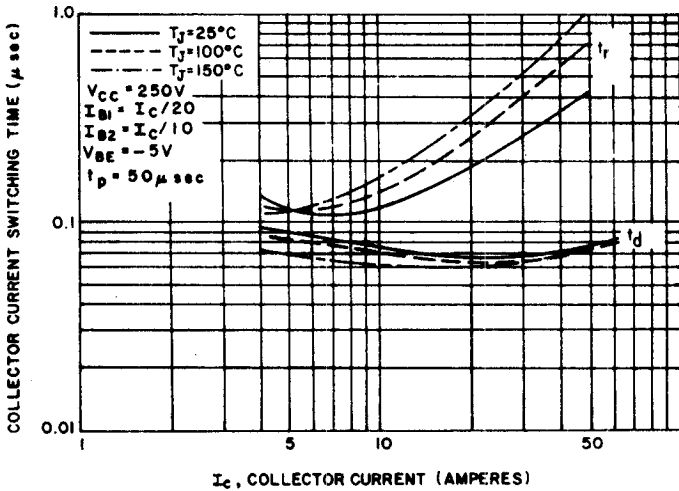

FIGURE 9. TURN-ON TIME (RESISTIVE LOAD) (D66DV ONLY)

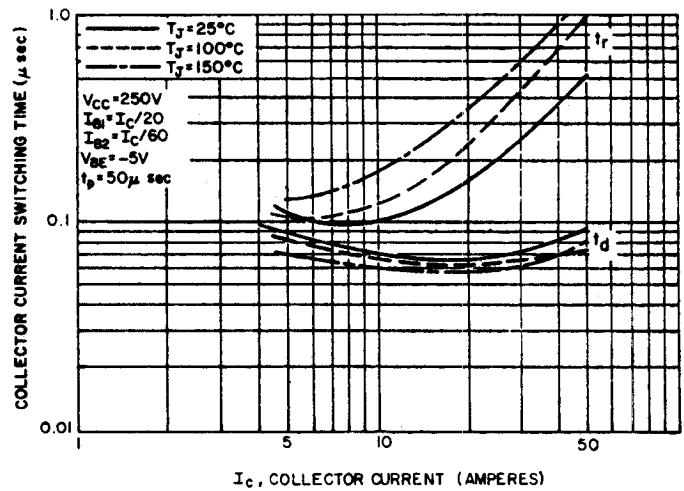

FIGURE 10. TURN-ON TIME (RESISTIVE LOAD) (D66EV ONLY)

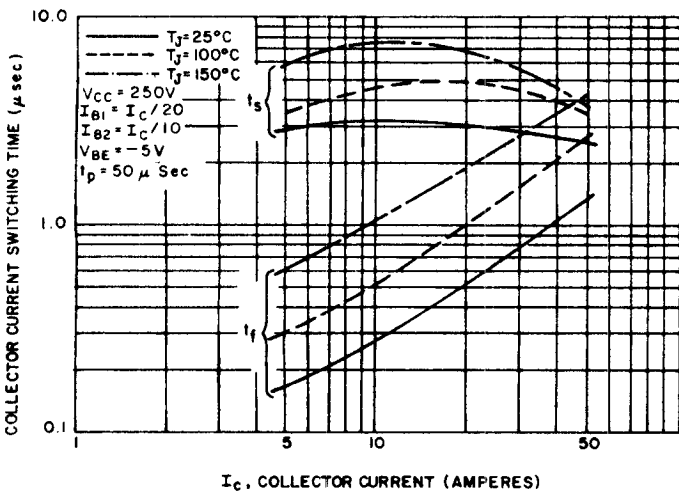

FIGURE 11. TURN-ON TIME (RESISTIVE LOAD) (D66DV ONLY)

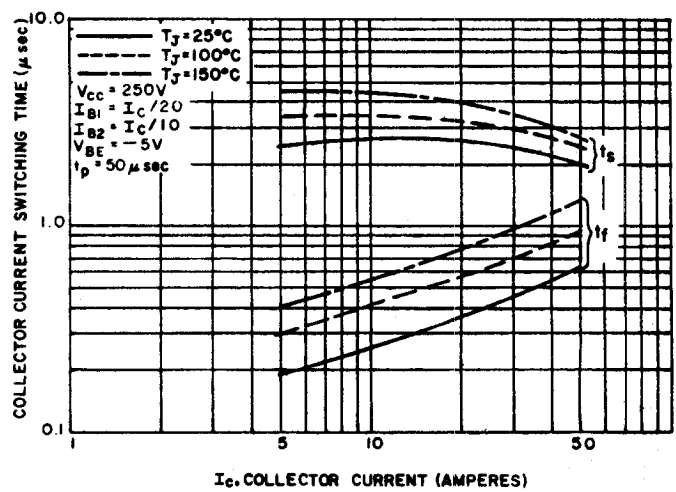
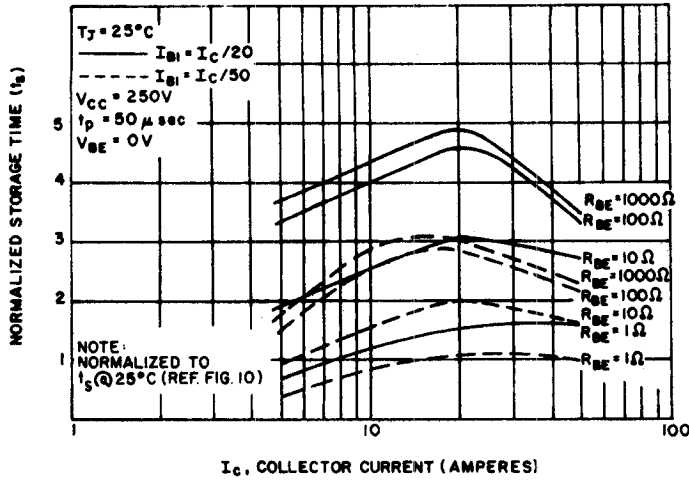
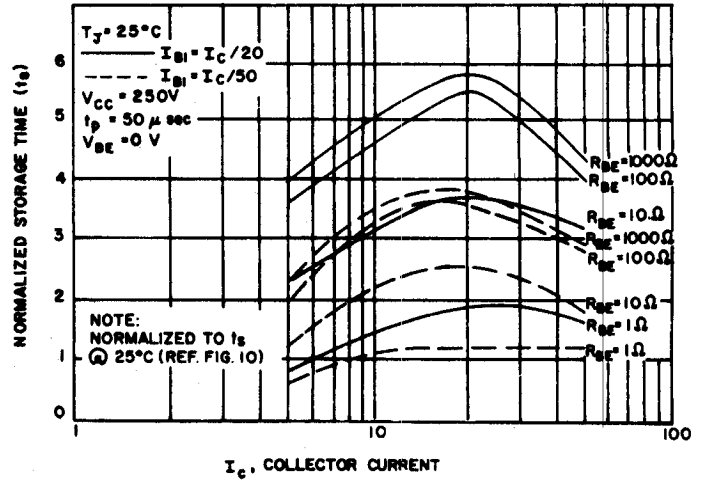

FIGURE 12. TURN-ON TIME (RESISTIVE LOAD) (D66EV ONLY)

# TYPICAL CHARACTERISTICS



**FIGURE 13. NORMALIZED RESISTIVE SWITCHING STORAGE TIME ( $R_{BE}$  VARIATIONS) VS COLLECTOR CURRENT (D66DV ONLY)**



**FIGURE 14. NORMALIZED RESISTIVE SWITCHING STORAGE TIME ( $R_{BE}$  VARIATIONS) VS COLLECTOR CURRENT (D66EV ONLY)**

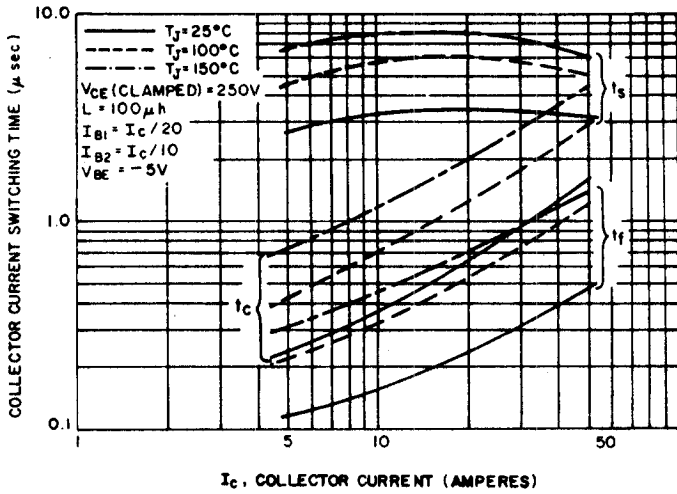

**FIGURE 15. CLAMPING INDUCTIVE TURN-OFF TIME (D66DV ONLY)**

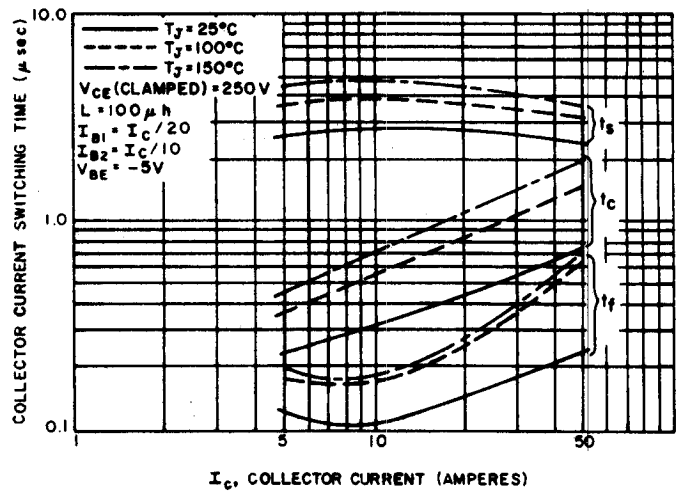

**FIGURE 16. CLAMPING INDUCTIVE TURN-OFF TIME (D66EV ONLY)**

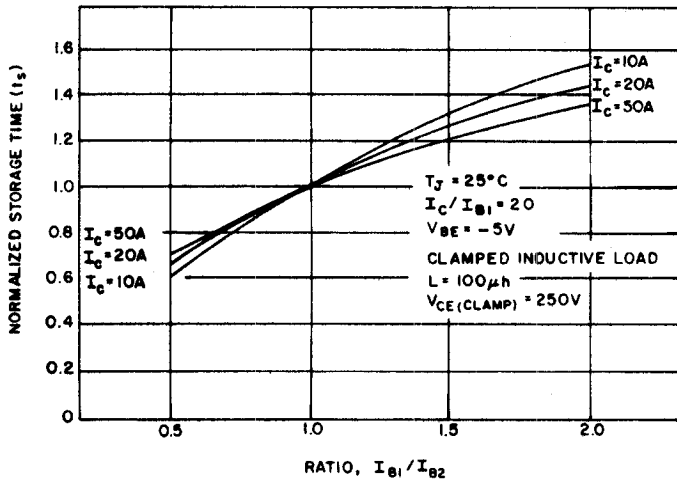

**FIGURE 17. STORAGE TIME VARIATION WITH  $I_{B2}$  (D66DV ONLY)**

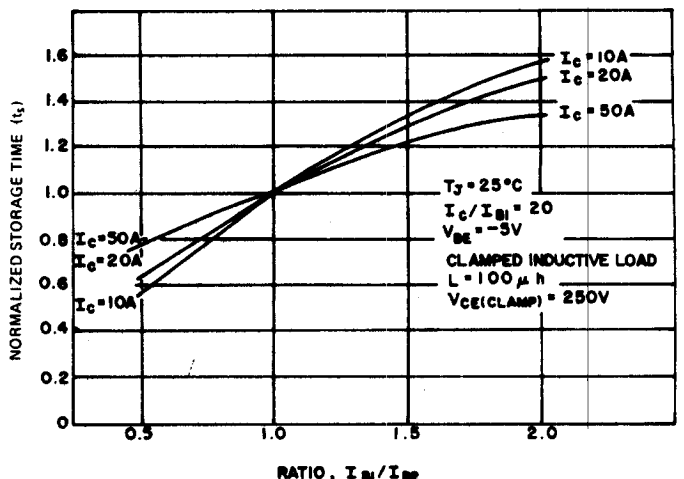

**FIGURE 18. STORAGE TIME VARIATION WITH  $I_{B2}$  (D66EV ONLY)**

# TYPICAL CHARACTERISTICS

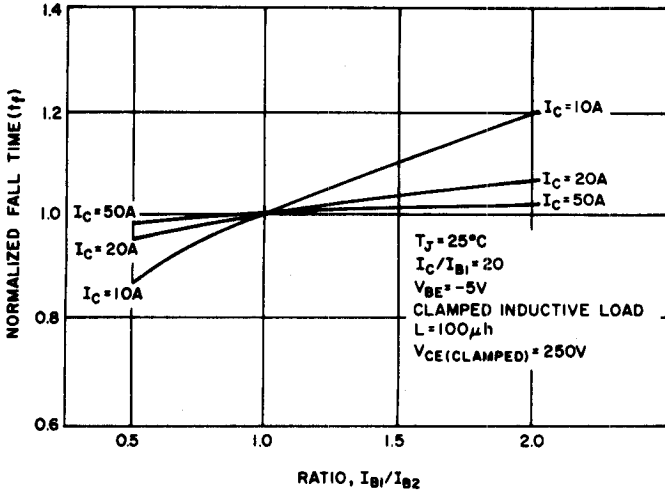

FIGURE 19. FALL TIME VARIATION WITH  $I_{B2}$  (D66DV ONLY)

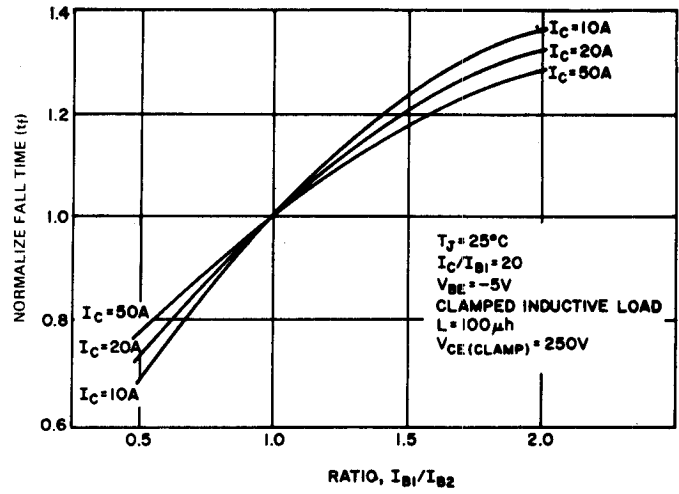

FIGURE 20. FALL TIME VARIATION WITH  $I_{B2}$  (D66EV ONLY)

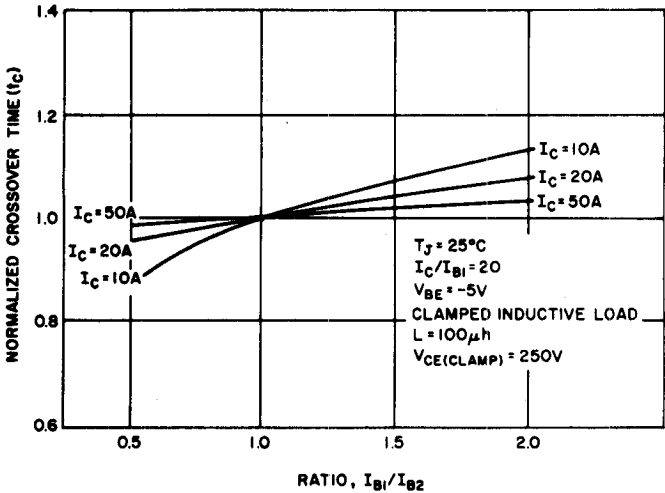

FIGURE 21. CROSSOVER TIME VARIATION WITH  $I_{B2}$  (D66DV ONLY)

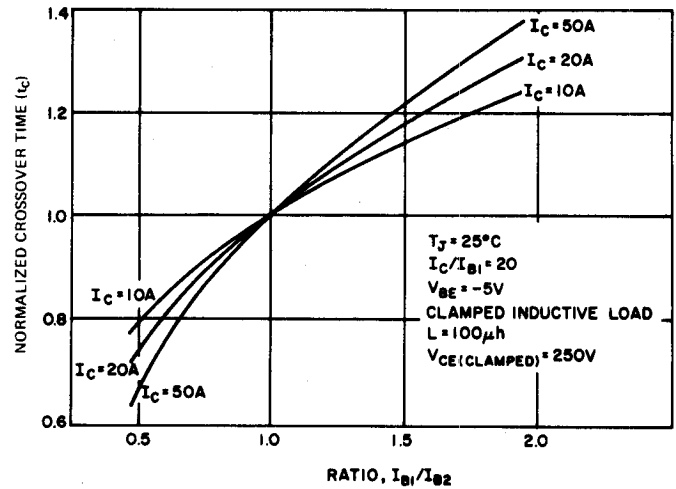

FIGURE 22. CROSSOVER TIME VARIATION WITH  $I_{B2}$  (D66EV ONLY)

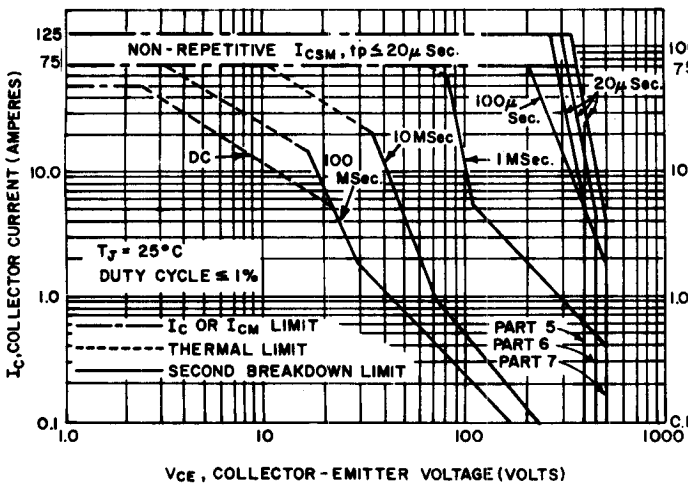

FIGURE 23. FORWARD BIAS SAFE OPERATING AREA

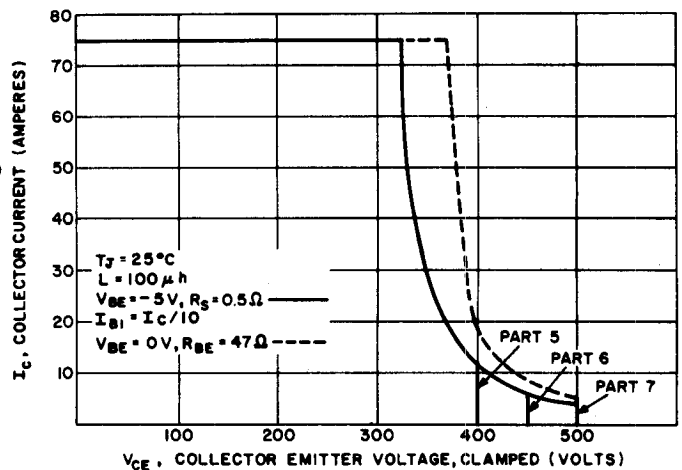

FIGURE 24. REVERSE BIAS SAFE OPERATING AREA (CLAMPED)

