

FANUC SYSTEM 6T-MODEL B

MAINTENANCE MANUAL

CONTENTS

1. GENERAL	1
1.1 Structure	2
1.2 Construction	6
2. PERIODICAL MAINTENANCE AND MAINTENANCE EQUIPMENT	11
2.1 Periodical maintenance	11
2.2 Maintenance equipment	21
2.3 Main of spare parts	21
3. TROUBLE SHOOTING	22
3.1 Procedures	22
3.2 Alarm list	23
3.3 Checking and countermeasures	61
3.4 Power supply voltage checking	74
3.5 Tape reader photo-amplifier adjustment	81
3.6 Connection diagram inside the NC	84
3.7 Status display by self-diagnostic function (DGN)	88
3.8 Block diagram of servo system	107
3.9 Confirmation of connections between control and velocity control	118
3.10 Confirmation of connections between NC and DC motor	134
3.11 Trouble shooting for servo unit	135
4. ADJUSTMENT	147
4.1 Procedure of adjustment	147
4.2 Connection of power supply	154
4.3 Frequency setting for velocity control unit	160
5. SETTING OF PARAMETERS	161
5.1 Procedure of display of parameters	161
5.2 Procedure of setting parameters	162
5.3 Parameter table	164
5.4 Details of parameters	170
5.5 Parameter initial setting data	208

6.	SETTING OF PCB	210
6.1	Setting and adjustment for control section PCB	211
6.2	Setting and adjustment for velocity control unit	230
6.3	Setting and adjustment for DC spindle servo unit PCB	236
6.4	Setting and adjustment for AC spindle servo unit PCB	244
6.5	Adjustment of spindle orientation	252
APPENDIX		
Appendix 1	Connection diagrams	271
Appendix 2	Connection between NC and servo motor	298
Appendix 3	Detailed description of power stabilizing unit	311
Appendix 4	Adjustment method of velocity control unit	330
Appendix 5	Parts specification of velocity control unit	339
Appendix 6	Maintenance for DC servo motor	344
Appendix 7	Maintenance for character display unit	359
Appendix 8	Operation table	365
Appendix 9	Tape code used for programming	368
Appendix 10	G function table	370
Appendix 11	Table fo range of command value	372
Appendix 12	Status at turning power on and reset	374
Appendix 13	Bubble memory initialize	376
Appendix 14	RAM test	382
Appendix 15	Lubrication oil of tape reader	384
Appendix 16	Display and setting PC-related signal and data	386
Appendix 17	Fuse specification	391

In this manual we have tried as much as possible to describe all the various matters.

However, we cannot describe all the matters which must not be done, or which cannot be done, because there are so many possibilities. Therefore, matters which are not especially described as possible in this manual should be regarded as "impossible".

1. GENERAL

FANUC SYSTEM 6T-MODEL B is a high-accuracy, high-performance fixed-software CNC for turning machines meeting needs in the world's market. The control circuit fully utilizes high-speed microprocessors, custom LSIs, and semiconductors, raising reliability and significantly improving cost/performance ratio.

FANUC SYSTEM 6T-MODEL B is a closed-loop CNC using world's most excellent and widely FANUC DC servo motor series employing a high-performance pulse encoder as the detector.

FANUC SYSTEM 6T-MODEL B incorporates a self-diagnostic function, providing very easy maintenance together with this maintenance manual.

- The microprocessor, monitoring the internal operating condition at all times, classifies the condition and displays it, and in addition, when a trouble occurs, displays alarm message at once and stops the NC, and furthermore, classifies the trouble in detail and displays it.
- All on/off signals input to and output from the NC can be displayed on the CRT display unit.
- Any on/off signal output from the NC can be transmitted in bits via the MDI unit.
- The current values of various parameters such as acceleration/deceleration time constants, rapid traverse speeds, etc. can be checked on the CRT display.

This manual discusses the preventive maintenance; quick trouble-shooting for possible failures (Chapter 3); check points, adjustments, and parameters in detail at the installation time of the NC (Chapter 4.5.6); and finally various technical information (Appendixes).

The author recommends that this manual be read in the order of the 1, 2, 4, 5, 6, 3 chapters, referring to relevant appendixes, and with the OPERATOR'S MANUAL (B-52244E) and the CONNECTING MANUAL (B52243E) as required.

Please refer to FANUC DC SPINDLE SERVO UNIT MAINTENANCE MANUAL (B-51649E), and FANUC AC SPINDLE SERVO UNIT MAINTENANCE MANUAL (B-53425E) for detail of each unit adjustment.

1.1 Structure

- 2 -

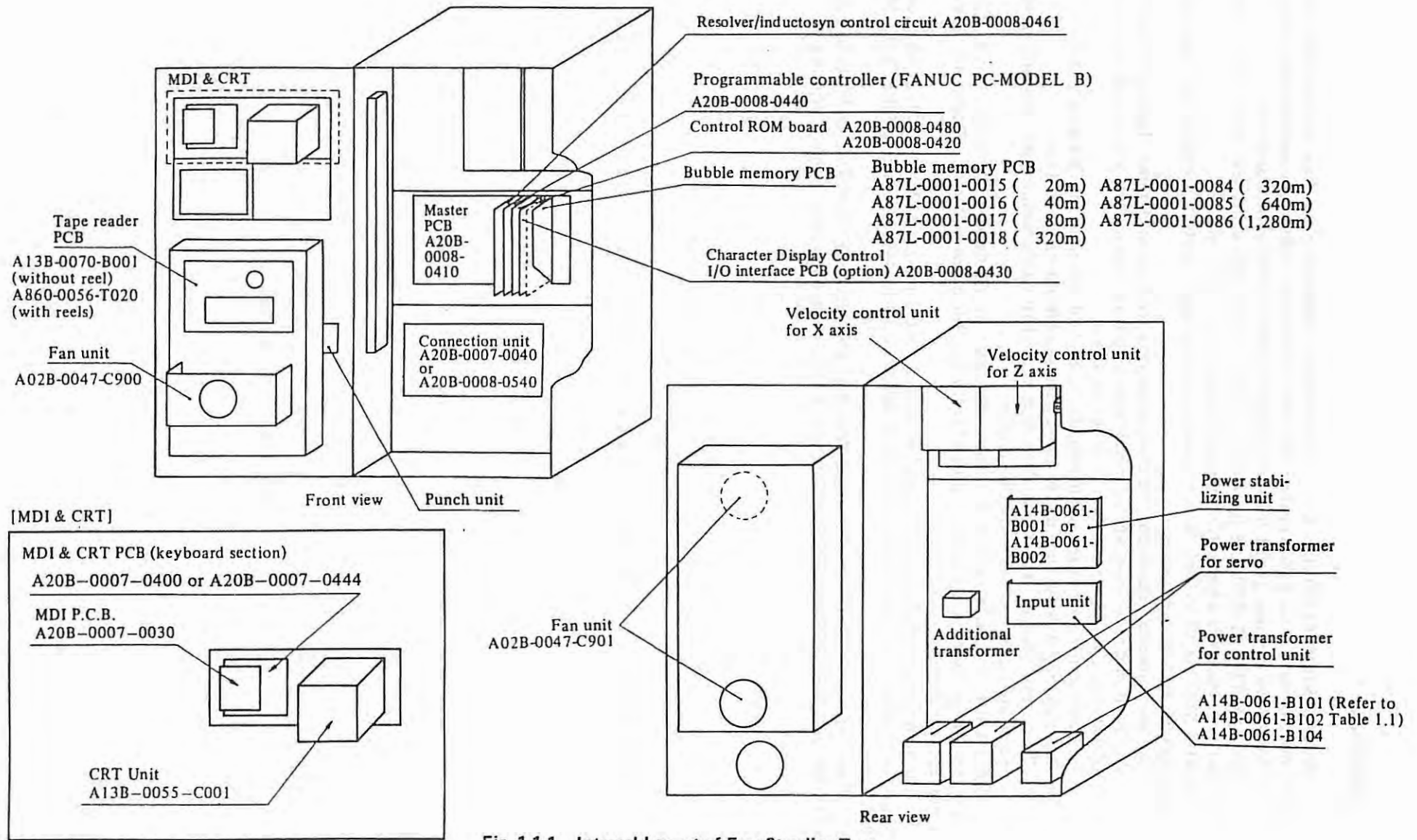

Fig. 1.1.1 Internal Layout of Free Standing Type

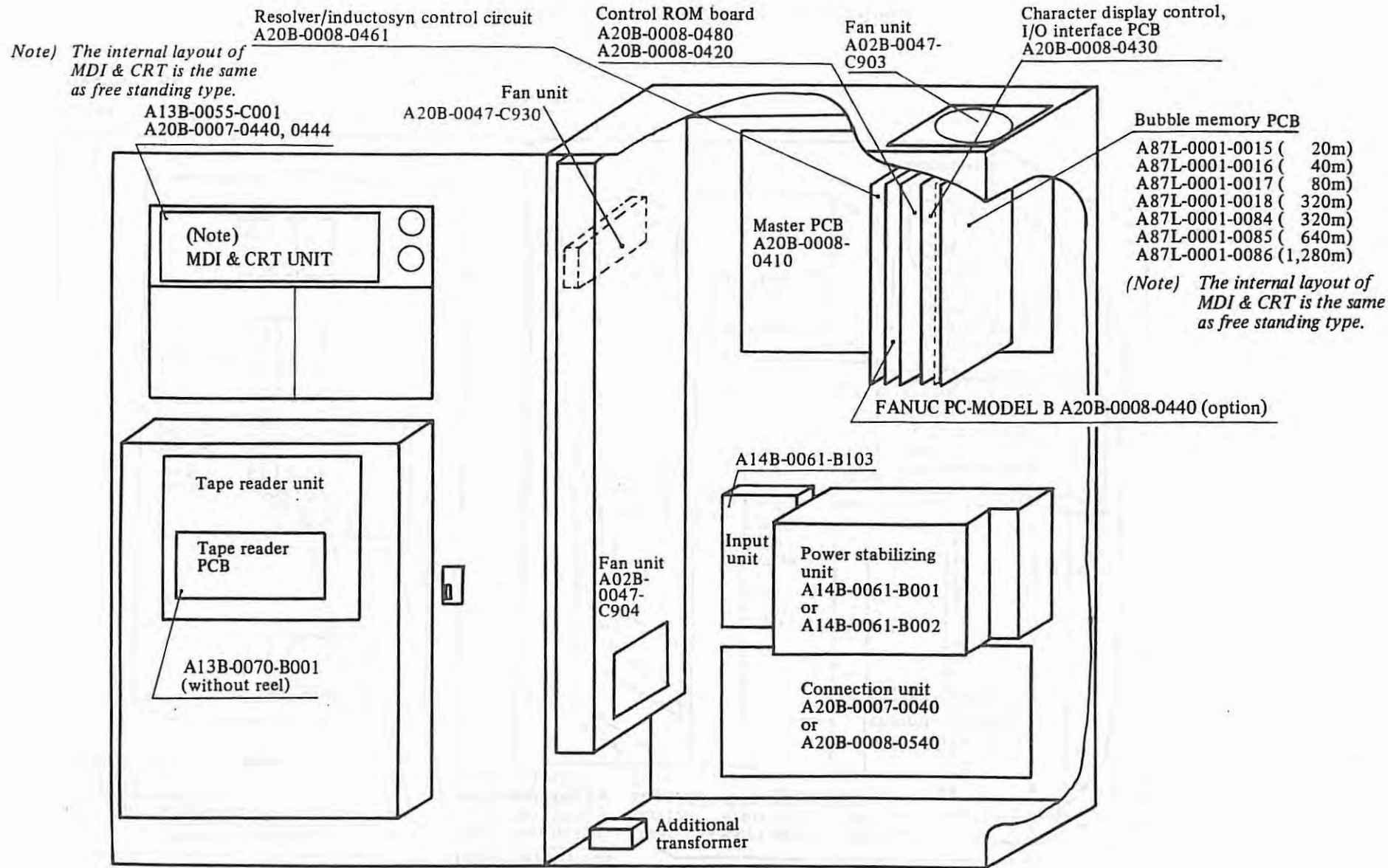

Fig. 1. 1. 2 Internal Layout of Built-in Type 1 Cabinet

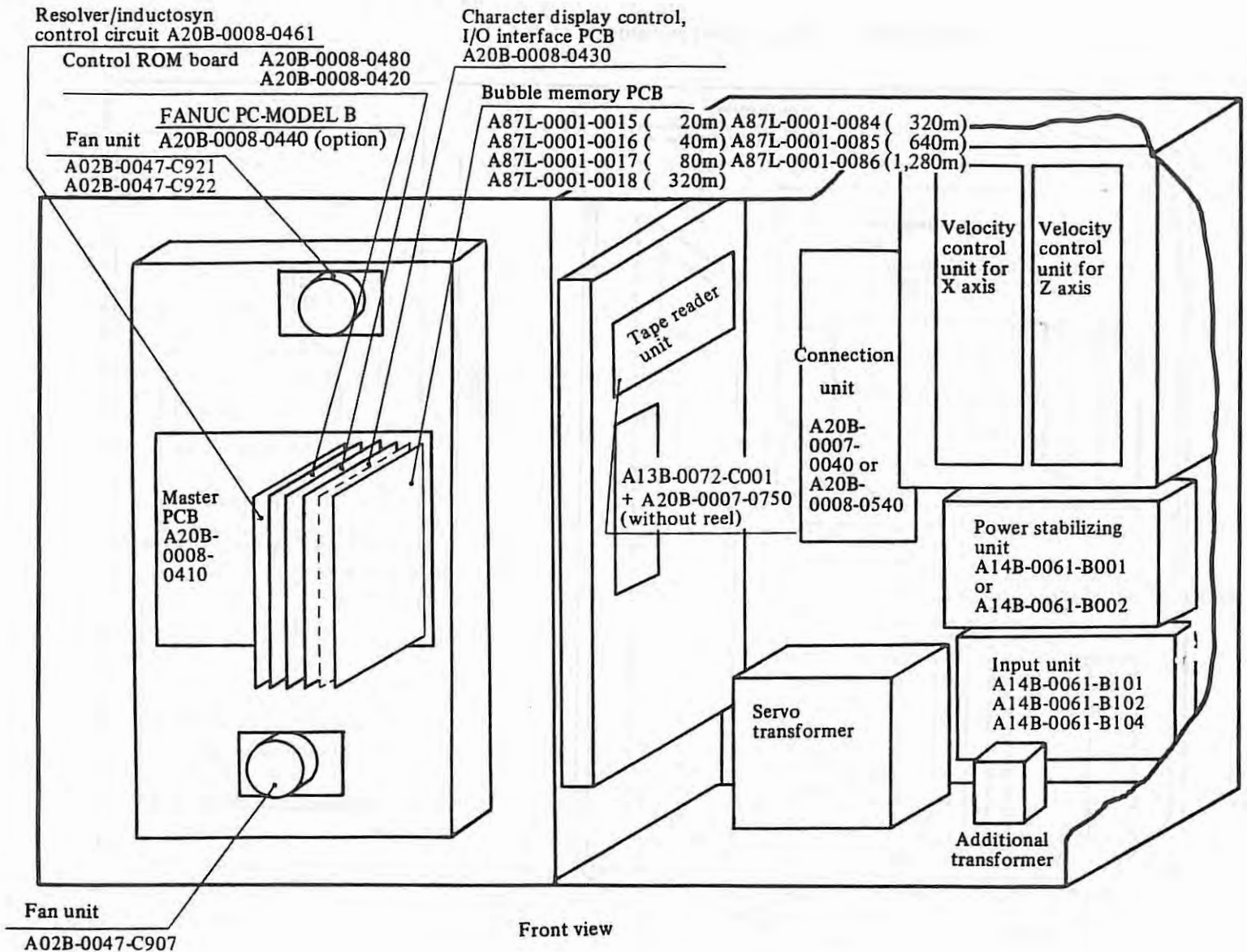

Fig. 1.1.3 Internal Layout of Built-in Type 2 Cabinet

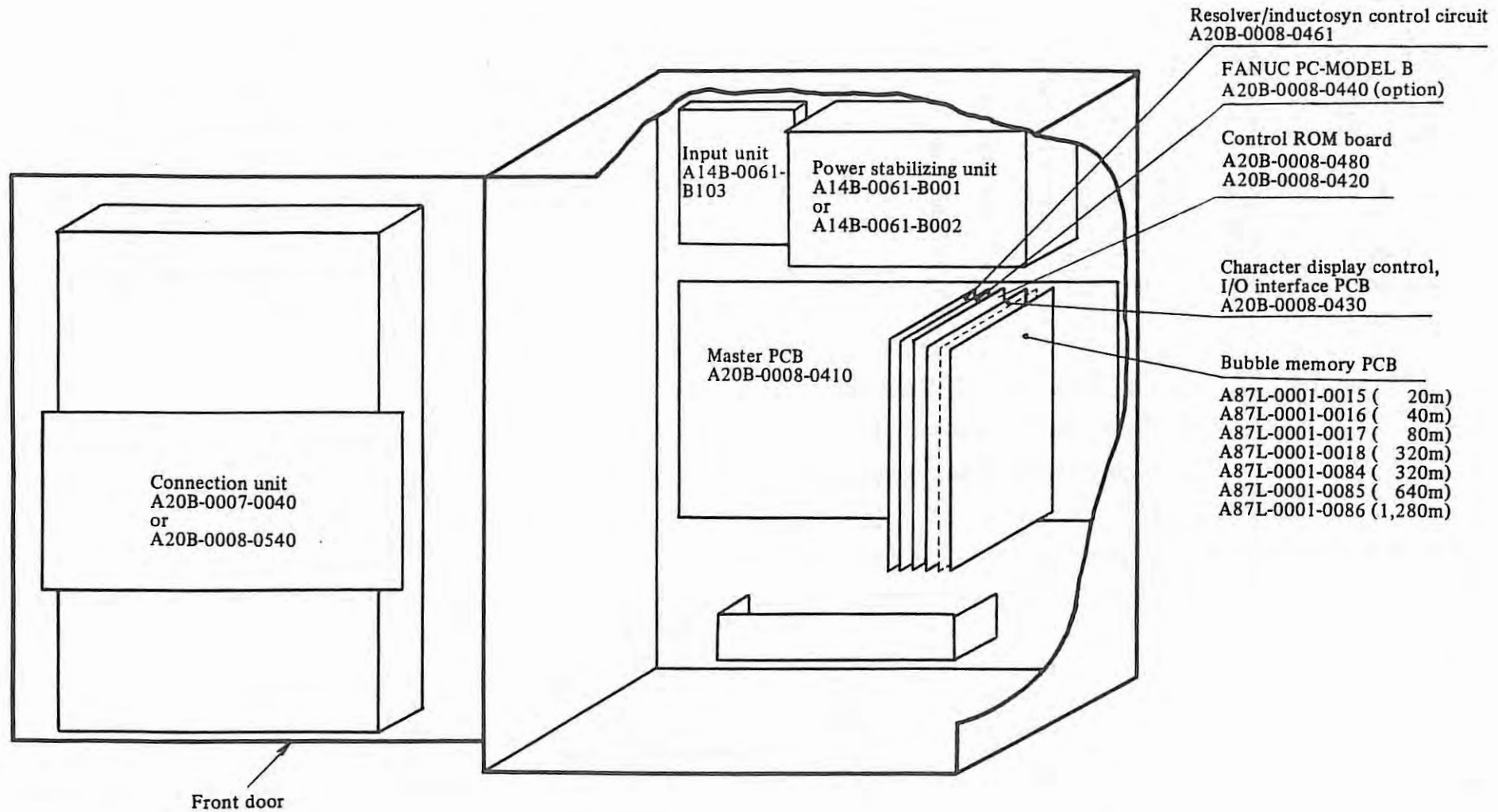
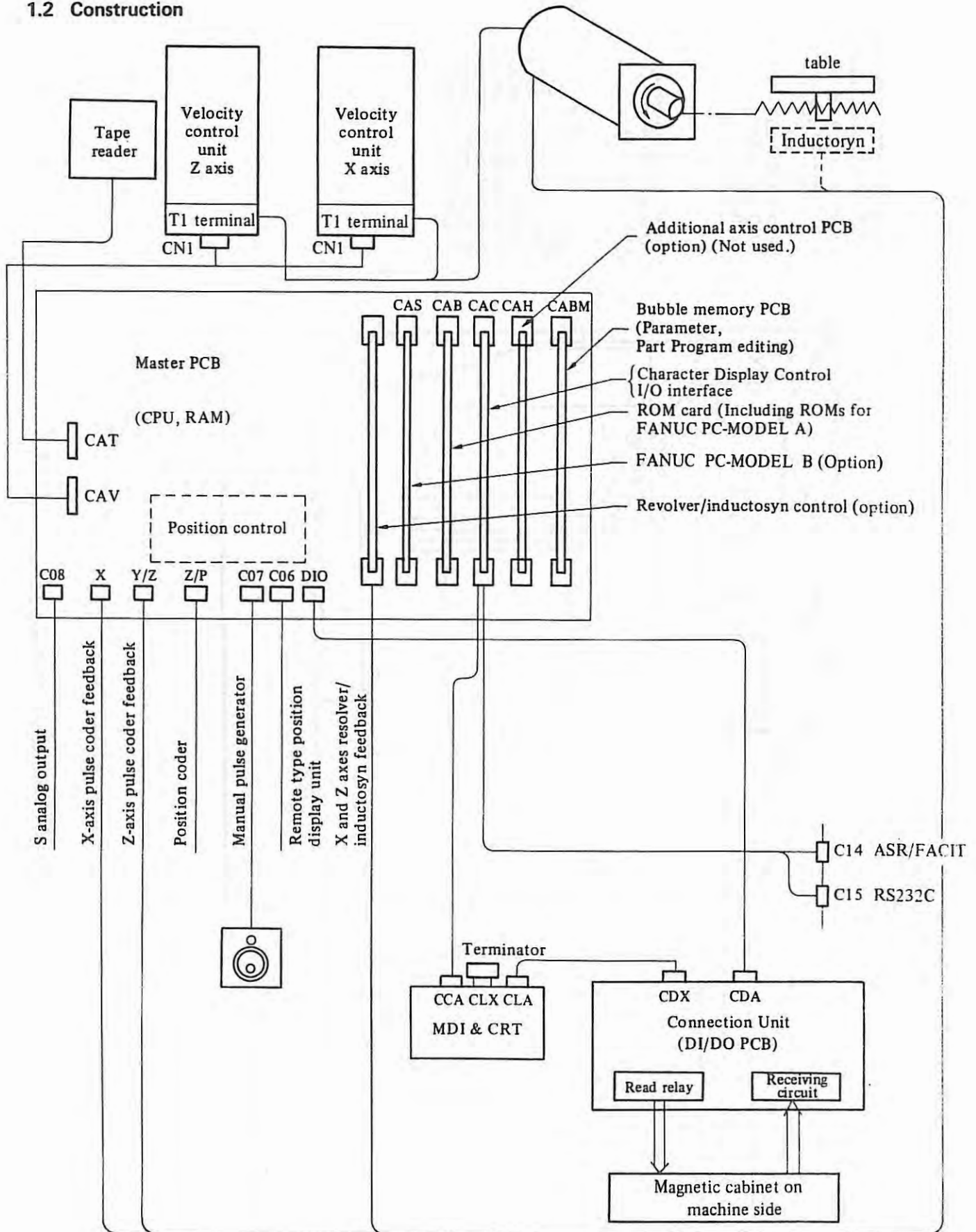

Fig. 1.1.4 Internal Layout of Unbundled Type Cabinet

1.2 Construction



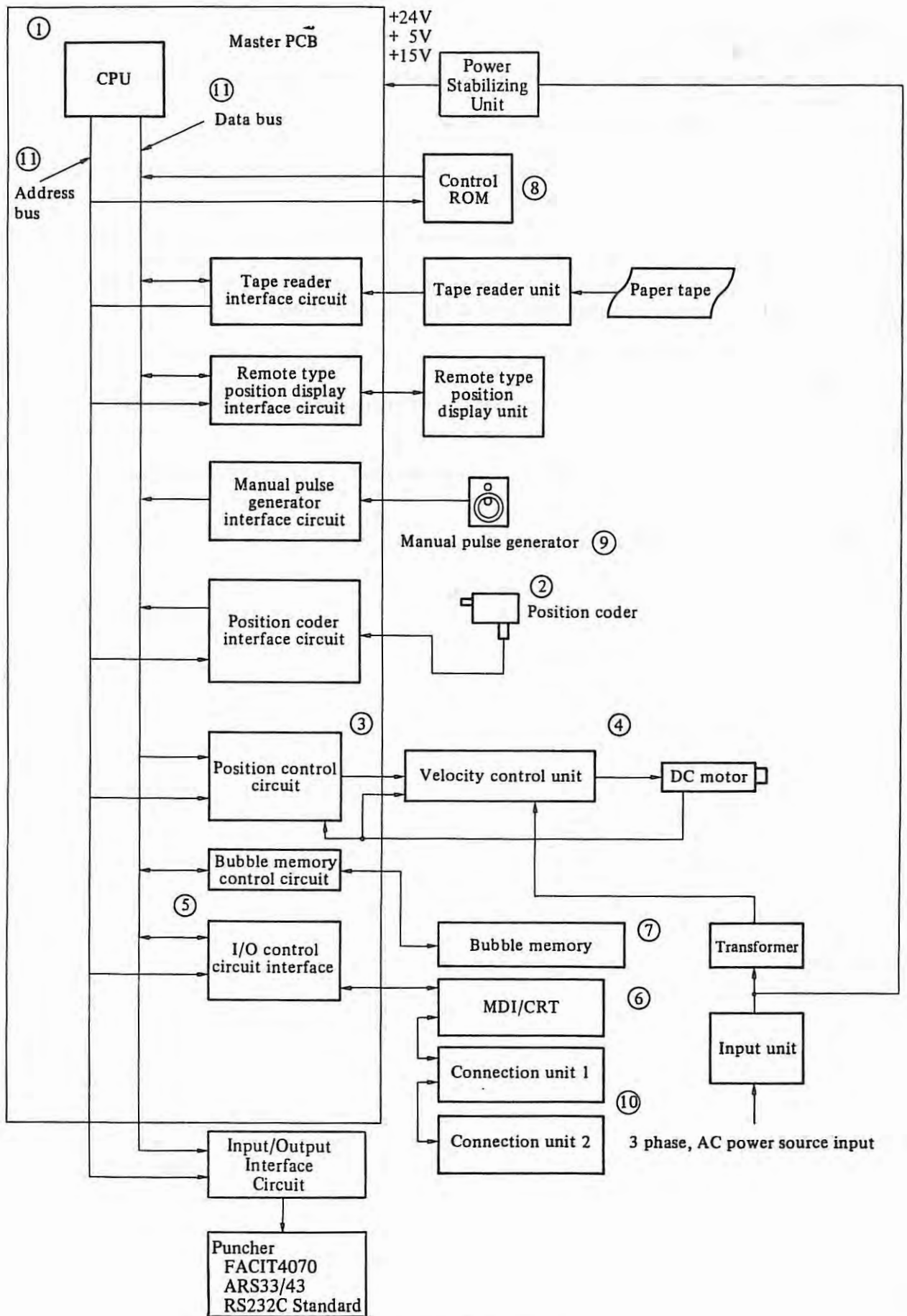

Fig. 1.2 Block Diagram

Explanation of Block Diagram

- ① CPU: Central Processing Unit
It controls each blocks through address bus and data bus by software write-in control ROM.
- ② Position Coder
It is a detector for detecting spindle rotation position.
- ③ Position Control
It controls velocity command voltage equalizing the command position from CPU with machine position detected by feedback pulses from pulse coder.
- ④ Velocity Control
It controls the motor revolution speed comparing the velocity command value and velocity feedback value.
- ⑤ I/O Control
It controls the data transmission of input/output signals from machine side and MDI & DPL/MDI & CRT.
- ⑥ MDI & CRT: Keyboard-type Manual Data Input & CRT character Display
- ⑦ Bubble Memory
It is one of memory elements utilizing magnetic bubble.
- ⑧ ROM (Read Only Memory)
No data can be written into this memory. ROM is exclusively used for read, and it normally stores control programs, constants, and other data.
- ⑨ Manual Pulse Generator
This generator is graduated with 100 divisions per rotation, and it generates pulses by turning the handle. It is used for fine feed adjustment.
- ⑩ Connection Unit
This unit controls I/O signals to and from the machine tool.
- ⑪ Address bus/data bus
These buses serve as memory address and data passages.

Table 1.2 Main components

Name	Symbol	Specification	Remark
Input unit		A14B-0061-B101	For free standing type and built-in type 2 cabinets, Capacity of servo unit fuse: 30A Domestic use
		A14B-0061-B102	For free standing type and built-in type 2 cabinets, Capacity of servo unit fuse: 30A Export use
		A14B-0061-B103	For built-in type 1 and unbundled type cabinets.
		A14B-0061-B104	For free standing type and built-in type 2 cabinet Capacity of servo unit fuse: 40A For both domestic and export use
Power stabilizing unit		A14B-0061-B001 or A14B-0061-B002	
Power supply ON/OFF Control PCB (Note 1)		A20B-0007-0340	Control circuit for power ON/OFF and external power ON/OFF (EON/EOF)
Power stabilizing PCB (Note 1)		A20B-0007-0330	For stabilizing + 5V, $\pm 15V$ and + 24V power
Tape reader unit		A13B-0070-B001	Without reel
		A860-0056-T020	With reels
Master PCB	A	A20B-0007-0041	CPU, Memory (Control program ROM, work RAM) Position control for 2 axes
Control ROM PCB	B	A20B-0008-0420 A20B-0008-0480	Control program ROM. FANUC PC-MODEL A
MDI PCB	L	A20B-0007-0030	MDI control circuit
MDI & CRT control PCB		A20B-0007-0440 or A20B-0007-0444	Switch circuit (Data switch, Address switch . . .)
Connection unit	D	A20B-0007-0040 or A20B-0008-0540	Control of I/O signals for the machine tool DI 96 signals Contact receiver: 88 signals Proximity switch receiver: 8 signals DO 64 signals Reed relay: 52 signals Photo coupler: 12 signals (For constant surface speed control)
Programmable controller (FANUC PC-MODEL B)	S	A20B-0008-0440	ROM for built-in type power sequence control (PC model B)

Name	Symbol	Specification	Remark
Character display control PCB I/O interface	C	A20B-0008-0430	Control circuit for MDI & CRT unit FACIT 4070, ASR33, 43, RS232C interface.
Bubble memory PCB	BMU	A87L-0001-0015	Tape length: 20m
		A87L-0001-0016	Tape length: 40m
		A87L-0001-0017	Tape length: 80m
		A87L-0001-0018	Tape length: 320m
		A87L-0001-0084	Tape length: 320m
		A87L-0001-0085	Tape length: 640m
		A87L-0001-0086	Tape length: 1280m
Resolver/inductosyn control	N	A20B-0008-0461	Resolver/inductosyn control
Velocity control unit (H series)		A06B-6405-C001, 2, 5, 6	It supplies motor with current.
Velocity control unit (M series)		A06B-6047-H001	For Model 00M
		A06B-6047-H002	For Model 0M, 5M
		A06B-6047-H003	For Model 10M, 20M
		A06B-6047-H004	For Model 30M
		A06B-6047-H005	For Model 30MH
Firing circuit P.C.B. (H series)		A20B-0007-0360, 1	It controls motor speed.
Firing circuit P.C.B. (M series)		A20B-0009-0320	It controls motor speed.
Position display PCB1 (Display control section)	J	A20B-0007-0411	Data transmit/Receiver type
Position display PCB2 (LED display section)		A02B-0007-0421	Used with PCB1 to light LEDs.

(Note 1) Power supply ON/OFF control PCB is included in input unit and Power stabilizing control PCB is included in the Power stabilizing unit.

2. PREVENTIVE MAINTENANCE

FANUC SYSTEM 6T-MODEL B is given considerations in design from the viewpoint of maintenance, such as reduction of regular check points to a minimum, easy adjustment, etc. On the other hand, it is important that the user should make the departments concerned fully know the concept of preventive maintenance to run the NC machine tool in a good condition for a long time.

Preventive maintenance needs the following:

- Routine check and adjustment.
- Arrangement of maintenance tools.
- Provision of spare parts.

2.1 Periodical Maintenance

(1) Tape reader cleaning

(a) Tape reader without reel

Item	Cleaning point	Reference drawing	Cleaning period	Cleaning method
1	Surface of read head (light sensing part)	Fig. 2. 1 (a) ①	Daily	Clean with gauze or a thin brush with pure alcohol.
2	Surface of read head (light emitting part)	Fig. 2. 1 (a) ②	Daily	
3	Tape retainer	Fig. 2. 1 (a) ③	Daily	
4	Tape path	Fig. 2. 1 (a) ④	Daily	
5	Capstan roller	Fig. 2. 1 (a) ⑤	Weekly	
6	Guide roller	Fig. 2. 1 (a) ⑥	Weekly	
7	Pinch roller	Fig. 2. 1 (a) ⑦	Weekly	
8	Assembly under tape path plate	Fig. 2. 1 (a) ⑧	Monthly	Clean with cloth or a brush.
9	Inside tape reader cover	Fig. 2. 1 (b) ⑨	Monthly	

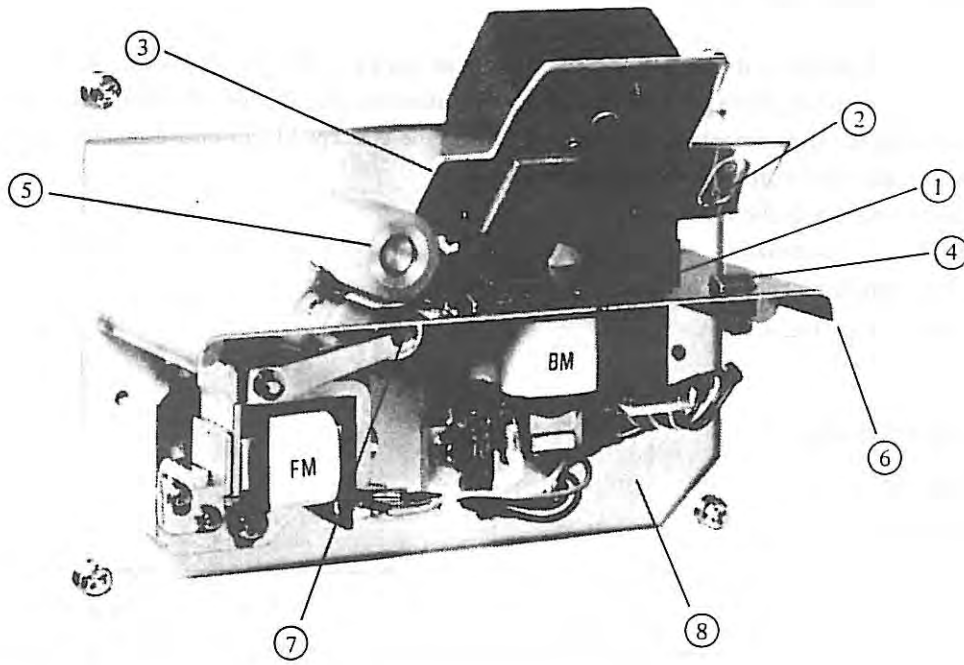

(A13B-0070-B001)

Fig. 2. 1 (a) Tape reader without reel front view (with cover removed)

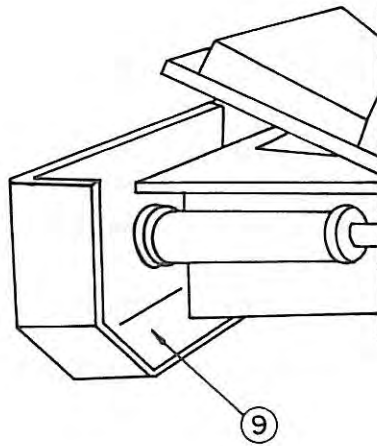

Fig. 2. 1 (b) Tape reader side view

(b) Tape reader with reels

Item	Cleaning point	Reference drawing	Cleaning period	Cleaning method
1	Surface of read head (light sensing part)	Fig. 2. 1 (c) ①	Daily	Clean with gauze or a thin brush with pure alcohol.
2	Surface of read head (light emitting part)	Fig. 2. 1 (c) ②	Daily	
3	Tape retainer	Fig. 2. 1 (c) ③	Daily	
4	Tape path	Fig. 2. 1 (c) ④	Daily	
5	Capstan roller	Fig. 2. 1 (c) ⑤	Weekly	
6	Guide roller	Fig. 2. 1 (c) ⑥	Weekly	
7	Pinch roller	Fig. 2. 1 (c) ⑦	Weekly	
8	Assembly under tape path plate	Fig. 2. 1 (c) ⑧	Monthly	Clean with cloth or a brush.
9	Inside tape reader cover	Fig. 2. 1 (d) ⑨	Monthly	

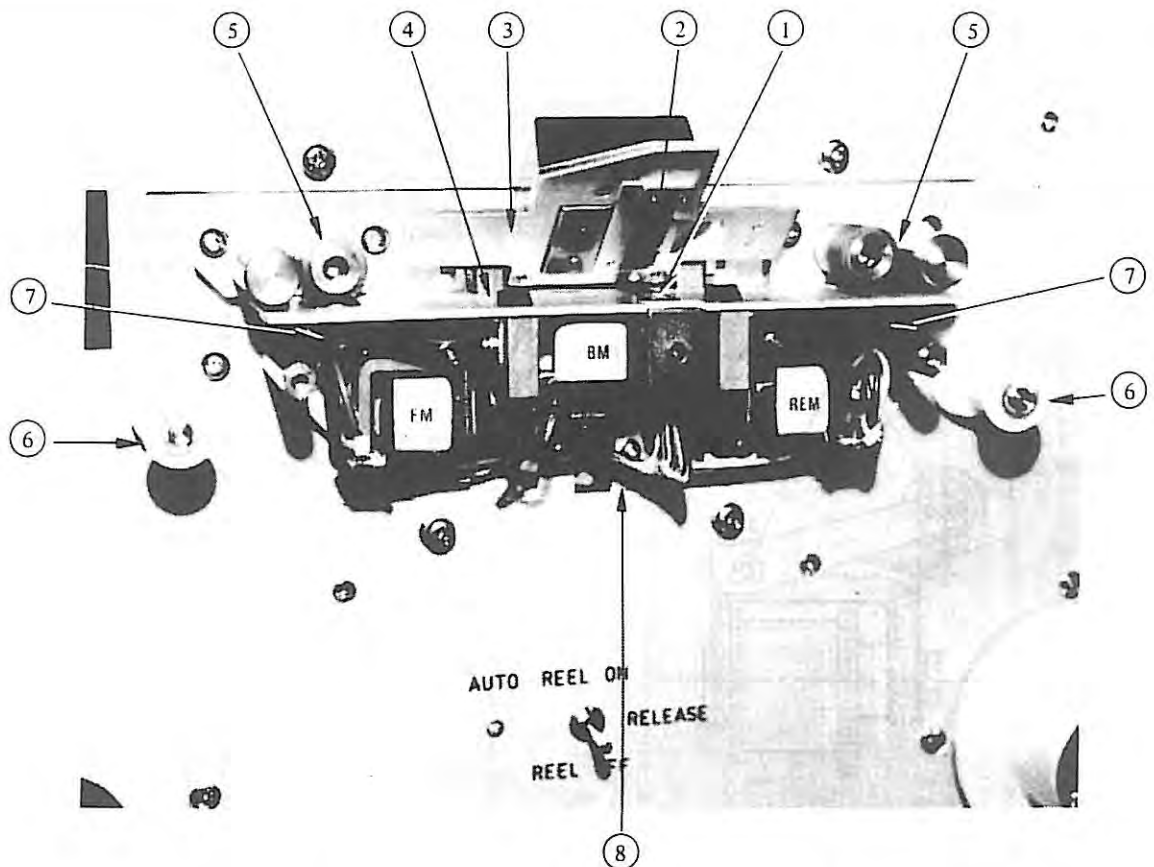

Fig. 2. 1 (c) Tape reader with reels front view (with cover removed)

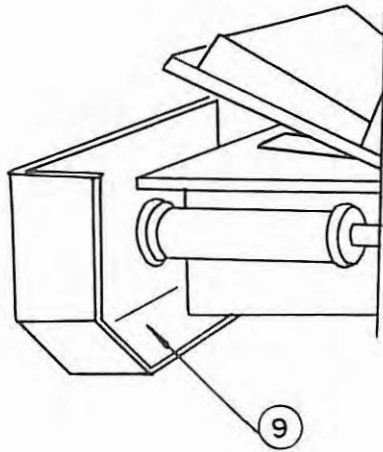

Fig. 2. 1 (d) Tape reader side view

(2) Tape reader lubrication

(a) Tape reader without reel lubrication

The routine lubrication points and lubrication periods are as follows:

Item	Lubrication point	Period	Lubricant (Note)	Amount
1	Magnet section	3 months	Light machine oil	1 drop
		1 year	Rocol paste	Sufficient to form a thin film
<p>See Fig. 2. 1 (a) 7</p>				

(b) Tape reader with reels

The routine lubrication points and lubrication periods are as follows:

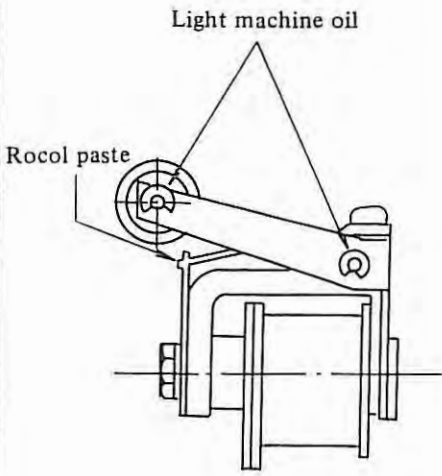
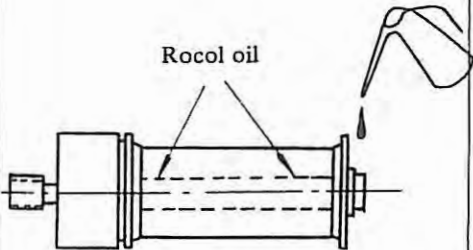
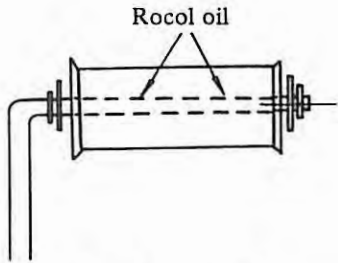
Item	Lubrication point	Period	Lubricant (Note)	Amount
1	<p>Magnet section</p>  <p>Light machine oil</p> <p>Rocol paste</p> <p>See Fig. 2. 1 (e) ①</p>	<p>3 months</p> <p>1 year</p>	<p>Light machine oil</p> <p>Rocol paste</p>	<p>1 drop</p> <p>Sufficient to form a thin film</p>
2	<p>Guide roller</p>  <p>Rocol oil</p> <p>See Fig. 2. 1 (e) ②</p>	6 months	Rocol oil	2 ~ 3 drops
3	<p>Tension arm guide roller</p>  <p>Rocol oil</p> <p>See Fig. 2. 1 (f) ③</p>	6 months	Rocol oil	2 ~ 3 drops

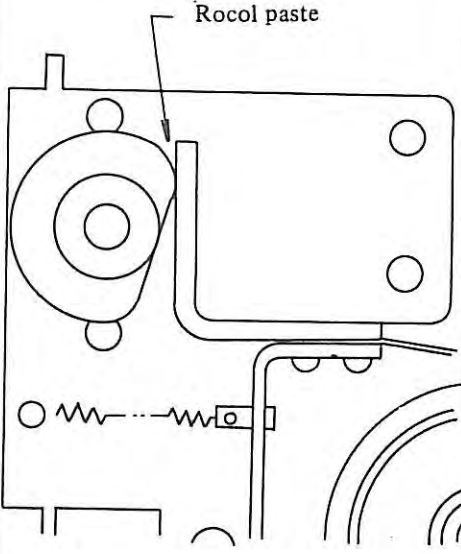
Item	Lubrication point	Period	Lubricant (Note)	Amount
4	Cam 	3 months	Rocol paste	Sufficient to form a thin film
See Fig. 2. 1 (g) ④				

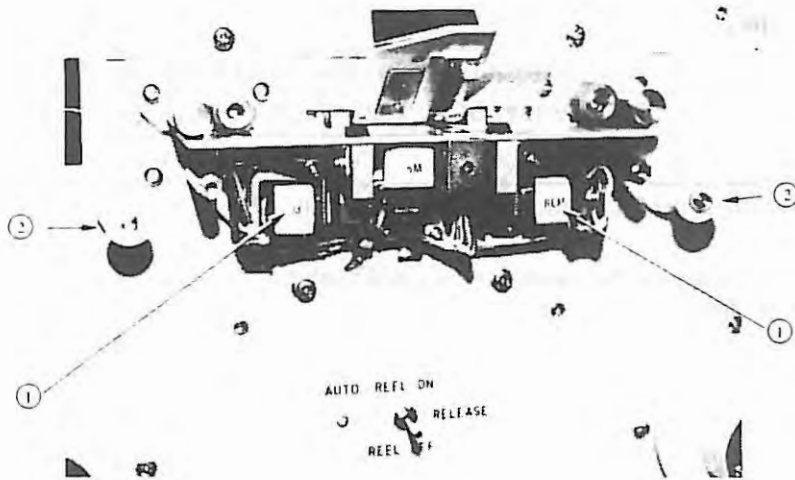

Fig. 2. 1 (e) Tape reader with reels front view (with cover removed)

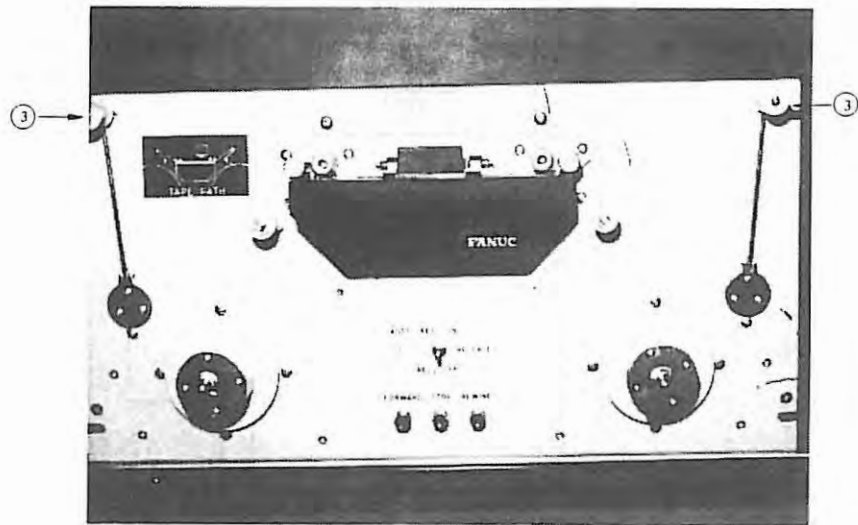

Fig. 2. 1 (f) Tape reader with reels front view

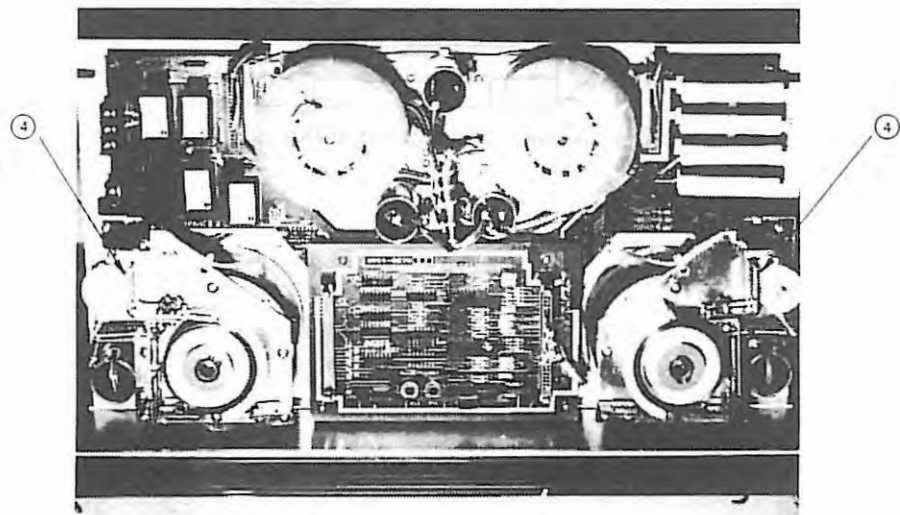

Fig. 2. 1 (g) Tape reader with reels rear view

(NOTE) Lubrication

Item	Name	Manufacturer
1	Rocol oil (ROCOL ASO)	ROCOL CO., Ltd. (U. K.)
2	Rocol Paste (ROCOL ASP)	ROCOL CO., Ltd. (U. K.)
3	Luna oil	Nippon Sekiyu

Refer to appendix 17 about characteristic of oil.

(3) Air Filter cleaning (For free standing type cabinet only)

When the air filter installed at the bottom rear of the equipment is dusty, the dust collection efficiency will drop, and the temperature in the equipment will rise. Therefore the filter must be cleaned weekly, as follows:

- (a) Remove the fastener, and remove the air filter from the bottom rear of the equipment.
- (b) Blow the air filter out with compressed air from the inside while shaking the filter lightly.
- (c) When the filter is very dirty, wash it in a neutral cleaner with pressure and then dry in the shade. (At this time, do not wash it with rubbing)

Wash it with pressure in the neutral cleaner and water (about 40°C or 104°F) (cleaner 5: water 95), then rinse it in clear water.

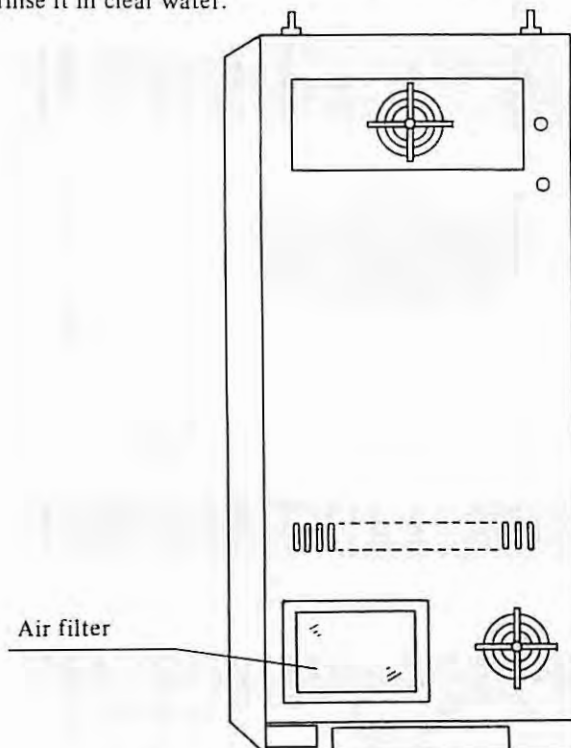

(Two servo power transformers of free standing type)

(4) Check and Cleaning of Motor Brush

- (a) Check and clean the motor brush in the way explained in the following. If the motor brush is abnormally worn because of forgetting the check, the motor can be damaged as the result, therefore, be sure to check the motor brush.
- (i) Periodic check should be made at the intervals listed in the following as the standard.
 - In the case of a general machine tool (lathe, milling machine, machine center, or such): Every one year
 - In the case of a machine tool with a high frequency of acceleration/deceleration (turret punch press or such): Every two monthsHowever, it is recommended that the check interval be determined judging the actual wear situation of the motor brush.
 - (ii) Confirm that the power supply to the DC servo motor (machine) is OFF. Immediately after the DC servo motor has been operated, the brush may be hot. In such a case, make the check after the brush is completely cooled.
 - (iii) Remove the brush cap, as shown in Fig. A, using a screwdriver which fits to the slot.
 - (iv) After taking out the brush completely, measure (visually) the length of the brush (see Fig. B). If the length of the remaining brush is shorter than 10mm (5mm for model 00, 00M), the brush cannot be used any more. Taking this fact into consideration, make a judgement as to whether the brush can be used until the next check time, and if necessary, replace the brush with a new one.
 - (v) Check the brush very carefully. If any deep groove or scar is found on the contact surface of the brush or if any mark of arcing is perceived on the brush spring, replace the brush with a new one. In this case, check the brush occasionally for about a month after the replacement, and if the same situation happens during this period, contact our nearest service station.
 - (vi) Blow off the brush dust in every brush holder with compressed air (factory air), and the brush dust will come out through another brush holder. Before using the compressed air, confirm that the air does not contain iron dust or a large amount of moisture.
 - (vii) After the check, put back the brush and tighten the brush cap fully. In this case, be careful that sometimes the brush spring is caught in between the conducting metal and brush holder and the brush cap cannot go as far as the depth. Confirm that all the brush caps are tighten into the respective brush holders to almost the same level. When putting the brush into the brush holder, sometimes the brush cannot smoothly slide due to the brush dust which adhered to the inside surface of the brush holder. In such a case, clean the inside surface of the brush holder with the tip of a screwdriver. (Take care not scratch the commutator surface.)
 - (viii) When replacing the brush, use just the same brush (in the quality, shape, etc.) as the existing one. After replacement of the brush, run the DC servo motor without load for a while to fit the brush surface to the commutator surface.

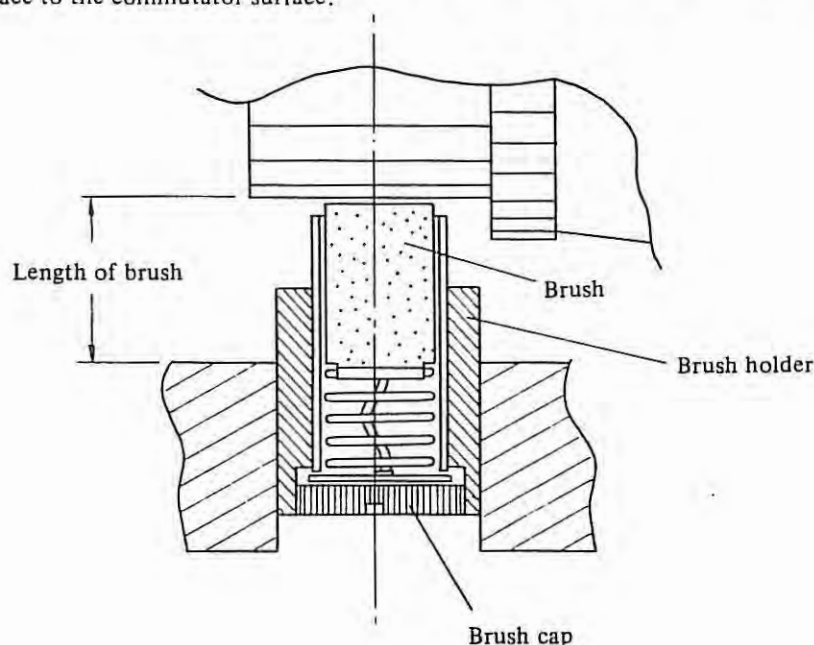
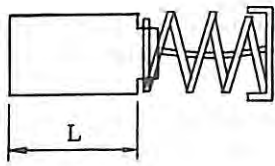

Fig. A Structure of Brush Holder



Motor model	Length of new brush	Usable length
Model 00, 00M	10 mm	5 mm
Model 0, 5, 0L, 5L, 0M, 5M, 10, 20, 30, 10M, 20M, 30M, 30MH	19 mm	10 mm

Fig. B Brush Length

(b) Cleaning of Heat-pipe Cooling Section (In the case of MODEL 10H, 20H, 30H, 30MH.)

A large amount of dust accumulated on the net and fin of the heat-pipe cooling section lowers the capability of the heat-pipe, and causes troubles due to the generated heat.

- (i) When dust is accumulated on the net, which disturbs the ventilation, remove the net and clean it.
- (ii) When a large amount of dust is accumulated on the fin (made up of many aluminum discs), clean the fin by blowing compressed air (factory air) to it. If the dust cannot be removed in this way, remove it with a thin rod or something like that.
- (iii) Since the dirtiness at the cooling section is largely dependent on the environment conditions, the frequency of periodic cleaning should be properly determined according to the operating environment. (Periodic check at every six months is the standard.)

2.2 Maintenance equipment

The author recommends the following tools.

(1) Measuring instruments

Instrument	Requirements	Usage
AC voltmeter	AC power-supply voltage can be measured with a tolerance of $\pm 2\%$ or downward.	Measurement of AC power-supply voltage
DC voltmeter	Maximum degree of 10V, 30V Tolerance of $\pm 2\%$ or downward (digital voltmeter may be required.)	Measurement of DC power-supply voltage
Phase rotation meter		Check of connection sequence of AC 3-phase input power
Oscilloscope	Frequency bandwidth of 5 MHz or upward, 2 channels	Adjustment of tape reader photoamplifier, etc.

(2) Tools

- ⊕ screw driver: large, medium and small
- ⊖ screw driver: large, medium and small

(3) Chemicals

Tape reader cleaning liquid (absolute alcohol) and oil.

2.3 Main of spare parts

Always keep the following consumption goods.

- Fuses (see Appendix 17.)
- Motor brush (see appendix 6.)

As required, provide P.C.Bs and units.

- P.C.B. and unit (see Table 1.2)
- Primary parts of the velocity control unit (see Appendix 5.)

3. TROUBLESHOOTING

3.1 Procedures

Trouble-shooting procedures are classified as below, according to the status of the failing NC.

- (1) No power can be turned on Section 3. 3. 1
- (2) Operation is not normal after power is turned on Section 3. 3. 2
 - (2)-1 Nothing is displayed on CRT screen
 - (2)-2 Position display screen is not displayed
- (3) Trouble shooting by alarm Section 3. 3. 3
- (4) LEDs on the master PCB light Section 3. 3. 4
- (5) Jog operation is impossible Section 3. 3. 5
- (6) Manual pulse generator does not operate Section 3. 3. 6
- (7) Synchronous feed or feed per revolution is no good Section 3. 3. 7
- (8) Tape reader does not operate normally Section 3. 3. 8
- (9) Automatic operation is impossible Section 3. 3. 9
- (10) No S4-digit analog output is produced Section 3. 3. 10
- (11) S4-digit analog output voltage linearity is not good Section 3. 3. 11
- (12) FACIT 4070 does not operate normally Section 3. 3. 12
- (13) ASR 33/43 does not operate normally Section 3. 3. 13
- (14) RS-232C interface does not operate normally Section 3. 3. 14
- (15) Stop position does not coincide with reference point in reference point return Section 3. 3. 15
- (16) Power-supply voltage checking Section 3. 4
- (17) Tape reader photo-amplifier adjustment Section 3. 5
- (18) Connection diagram inside the NC Section 3. 6
- (19) Status display by self-diagnostic function (DGN) Section 3. 7
- (20) Block diagram and standard setting of servo system Section 3. 8
- (21) Confirmation of connections between NC and velocity control unit Section 3. 9
- (22) Confirmation of connections between NC and DC servo motor Section 3. 10
- (23) Trouble shooting for servo unit Section 3. 11

Survey on Trouble Phenomena

Inform to FANUC Service Center of data on the following items checked, when a trouble occurred.

- (1) Phenomena
 - (i) Mode in which the trouble occurred
 - (ii) Position where the trouble occurred
 - (iii) Alarm number
 - (iv) Trouble frequency
 - (v) Error amount in positioning
 - (vi) Display of the position of trouble occurrence
- (2) Other information
 - (i) Software series and edition number displayed on the CRT when the power is turned on (see Section 3.3.2)
 - (ii) Parameter contents
Inform to FANUC Service Center of the results of compare the parameter table attached to the NC and Setting parameters in the NC.
 - (iii) Program contents and cutter compensation values for automatic operation
 - (iv) Contents of other items if checked

3.2 Alarm list

When an alarm occurs, ALARM MESSAGE is automatically displayed on the CRT.
Alarms are classified as follows:

Classification	Alarm number	Remarks
Program errors, Operation errors, etc.	000 ~ 170	Refer to operator's manual and change the program
Errors on stroke end limit switches.	210 ~ 225	Refer to item 3.3
Errors on servo system	400 ~ 427	
Errors on Connection Unit, MDI & CRT or FANUC GROGRAMMABLE CONTROLLER	600 ~ 607	
Overheat of control section or motor	700, 702	
Errors on memory (In this case, spare PCB is needed.)	900 ~ 999	

(i) Program errors or operation error

Number	Content	Remarks
000	Re-apply the power after the parameter has been input. (Parameter No.012~015, 018, 027, 028, 031, 032, 082, 083, 086, 087, 090, 124, 125, 128, 129, 316)	
001	TH alarm (A character with incorrect parity was input). Correct the tape.	Refer to Item 3.3.3
002	TV alarm (The number of characters in a block is odd). This alarm will be generated only when the TV check is effective. Correct the tape.	"
003	Data exceeding the maximum allowable number of digits was input.	Refer to appendix 11
004	A numeral or the sign (-) was input without an address at the beginning of a block.	Refer to operator's manual
005	The address was not followed by the appropriate data but was followed by another address or EOB code.	"
006	Sign "-" input error (Sign "-" was input after an address with which it can't be used. Or two "-" signs were input.)	"
007	Decimal point "." input error (A decimal point was input after an address with which it can't be used. Or two decimal points were input.)	"
008	The switch position of tape reader was not AUTO (without reel) or REEL ON/REEL OFF (with reels).	"
009	Unusable character was input (B, C, Y, V, J, H)	"
010	An unusable G code was commanded. (This alarm is generated also when a G code with which the control is not equipped as an option is commanded.)	"
011	Feed rate was not commanded at cutting feed or the feedrate was inadequate.	"
012	E code was commanded in the NC which does not have the E6 digits option.	"
014	Increase/decrease value given by address K exceeds the max. programmable dimension or the lead becomes negative value as the result of decrease in variable thread cutting.	"
022	In circular interpolation, radius designation was performed in the NC which is not equipped with the radius designation option.	"
023	In circular interpolation by radius designation, negative value was commanded for address R.	"
029	An offset value exceeded 6 digits. The offset value should be reset	
030	The tool offset number is too large for the T function.	"
031	In setting of offset amount by G10, the offset number following address P was excessive or it was not specified.	"
032	In setting of offset amount by G10, the offset amount was excessive.	"
033	An intersecting point of tool nose R can not be calculated.	"
034	The offset was started or canceled during G02 and G03 mode in tool nose radius R compensation.	"
035	Skip cutting (G31) was commanded in tool nose radius compensation mode.	"
038	Overcutting will occur in tool nose radius compensation because the arc start point or end point coincides with arc center.	"
039	In tool nose radius compensation, chamfering or corner R is commanded with start-up, cancel or G41/G42 change command. Or, the over-cutting will occur in chamfering or corner R.	"

Number	Content	Remarks
040	In tool nose radius compensation during canned cycle G90/G94 mode, the over-cutting will occur.	Refer to operator's manual
041	In tool nose radius compensation, the over-cutting will occur.	"
047	One of G27 to G30 was commanded for an axis which does not have a reference point.	"
048	A G30 or G27 was commanded without performing reference point return after the power was turned on. A move command was executed without performing reference point return after the power was turned on in an NC which includes optional stored stroke limit.	"
050	The chamfering or a corner R was commanded in a block which includes a thread cutting command.	"
051	The block after a block containing a chamfering or a corner R was not a G01 command.	"
052	The move direction or the move amount in the block following a chamfering or a corner R command was not adequate.	"
053	Two or more of I, K and R values were commanded in a block in the chamfering or corner R command.	"
054	The block in which the chamfering or the corner R was commanded includes a taper command.	"
055	The move distance in the block which includes the chamfering or the corner R is smaller than the chamfering distance or the corner R.	"
056	The addresses X (or Z) and I (or K) were commanded together in the block which includes the chamfering command. G01 X (U) ——— I ——— ; or G01 Z (W) ——— K ——— ;	"
059	Selected work number was not found. (External Work Number Search A Function.)	"
060	Commanded sequence number was not found in the sequence number search.	"
061	Either address P or Q was not commanded in the block which includes a G70, G71, G72 or G73 command.	"
062	<ul style="list-style-type: none"> • The number following address D in the block which includes a G71, G72 or G73 command was not positive. • The number following address K or D in the block which includes a G76 command was not positive. The number following address A in the block which includes a G76 command was not an usable number. • The address X was commanded in spite of the numeral following address I being zero or the address Z was commanded in spite of the numeral following address K being zero in the block which includes a G74 or G75 command. 	"
063	The sequence number which was specified by address P or Q in the block which includes a G70, G71, G72 or G73 command was not found.	"
065	The block which was specified by the address P in the block which includes a G71, G72 or G73 command does not include a G00 or G01 command. Z (w) or X (u) is commanded in the block which was specified by the address P in the block which includes a G71, G72.	"

Number	Content	Remarks
066	One of the G codes other than G00, G01, G02, G03 or G04 was commanded between the two blocks specified by address P and Q respectively in the block which includes the G70, G71 or G72 command.	Refer to operator's manual
067	Either G70, G71, G72 or G73 was commanded in the tape mode or the MDI mode. (G70, G71, G72 and G73 can be commanded in the memory mode only.)	"
068	The number of pockets exceeded 10 in G71 or G72 of type II.	"
069	In a block of G70, G71, G72 or G73, the last move command specified by the addresses P and Q is included chamfering or corner R.	"
070	The memory area is insufficient.	Refer to Item 3.3.3
071	The address to be searched was not found.	Refer to operator's manual
072	The number of programs to be stored exceeds 95 or 191. (191 is an option)	"
073	The program number has already been used.	"
074	The program number is other than 1 ~ 9999.	"
075	Neither program number nor sequence number were found at the start block of the program.	"
076	The address P was not commanded in the block which includes a M98 command.	"
077	The subprogram was called in triple. (Quintet with user macro option)	"
078	The sequence number which was specified by address P in the block which includes a M98 or M99 was not found or the sequence number which was specified by GOTO command was not found.	"
079	Memorized program and tape contents do not coincide. (Program collation)	"
080	Measuring position reach signal was not ON with specified area by parameters. (Automatic Tool Offset Function)	"
081	T code was not commanded and automatic tool offset was command. (Automatic Tool Offset Function)	"
082	T code and automatic tool offset was commanded in the same block. (Automatic Tool Offset Function)	"
083	Axis command was error in automatic tool offset command or the data was incremental command. (Automatic Tool Offset Function)	"
085	When entering in the memory by using RS232C interface, an overrun or framing error was generated. (Alarm detected on NC side.)	"
086	In reading or in output by RS232C interface, transmission or I/O device trouble occurs. (Alarm is detected on I/O device side and issued to NC side.)	"
087	Input data exceeded to character after sending out DC3 (tape reader stop code) in entering from RS232C interface.	"
088	Data error signal "DERR" was inputted. (External Input Tool Offset A Function)	"
089	BCD data was inputted except 0 to 9. (External Input Tool Offset A Function)	"

Number	Content	Remarks
090	The reference point return cannot be performed normally because the reference point return start point is too close to the reference point or one revolution signal is not input owing to fault in the pulse coder.	Refer to operator's manual
091	Reference point return cannot be executed normally, because the feedrate is too low to synchronize the one-revolution signal of the pulse coder with the reference counter. (This alarm will occur also when the reference point return start point is too close to the reference point.)	"
092	The commanded axis by G27 (reference point return check) did not return to the reference point.	"
094	No P type can be specified for program restart (because after program interruption, coordinate system setting or ORIGIN, etc. was executed.)	"
096	No P type can be specified for program restart (because after program interruption, work zero point offset value changed.)	"
097	No P type can be specified for program restart (because after power is turned on, no automatic operation has been executed.)	"
098	When program restart was commanded with no reference point return after the power was turned on or after emergency stop or stroke limit alarm was released, and a G28 was found during block search by a program restart command.	"
099	A move command was performed in the MDI mode after the search for program restart.	"
100	The switch to set parameters is on. Push the reset button after turning off the switch.	"
101	The power was turned off while rewriting the contents of memory in the part program storage & editing operation. When this alarm is generated, you must turn on the power while pushing the DELET and RESET buttons to clear the memory.	"
110	Absolute value of data of fixed point representation exceeds the upper bound (99999999).	"
111	Exponent of data of floating point representation exceeds the upper bound.	"
112	Divisor is 0.	"
113	A function that cannot be used by custom macro A is used.	"
114	Format error except for <Format>	"
115	Value not defined as variable number is assigned.	"
116	Left side of substituted sentence is a variable of prohibited substitution.	"
118	Nesting of brackets exceeds 5.	"
119	Argument of SQRT is negative. Or argument of BCD is negative or composed of the data other than 1 to 9.	"
122	Nesting of macro exceeds 4.	"
123	Macro control command is used in tape mode.	"
124	DO-END is not 1 : 1 corresponding.	"
125	Format error of <Formula>	"
126	Not $1 \leq n \leq 3$ in DO n	"
127	NC command and macro command are mixed.	"
128	Not $0 \leq n \leq 9999$ in GO TO n	"

Number	Content	Remarks
129	Unallowable address is used in (Argument assignment)	"
130	In external data input, greater-address data contains an error.	"
131	In external alarm message, five or more alarms have occurred.	"
132	In external alarm message clear, no corresponding alarm number exists.	"
133	In external alarm message and in external operator message, smaller-address data contains an error.	"
170	Programs of numbers 8000-8999 and 9000-9899 are being edited. But this alarm occurs only when parameter setting inhibits these programs to be edited. (See parameters 318-PRG-9, 391-PRG-8)	"

(ii) Error on stroke end limit switch

Number	Content	Remarks
210	The movable part of machine touched the X axis plus stroke limit switch.	Refer to Item 3.3.3
211	The movable part of machine touched the X axis minus stroke limit switch.	"
212	While the X axis was moving in the plus direction, it entered into the forbidden area of the stored stroke limit 1.	"
213	While the X axis was moving in the minus direction, it entered into the forbidden area of the stored stroke limit 1.	"
214	While the X axis was moving in the plus direction, it entered into the forbidden area of the stored stroke limit 2 or 3.	"
215	While the X axis was moving in the minus direction, it entered into the forbidden area of the stored stroke limit 2 or 3.	"
220	The movable part of the machine touched the Z axis plus stroke limit switch.	"
221	The movable part of the machine touched the Z axis minus stroke limit switch.	"
222	When the Z axis was moving in the plus direction, it entered into the forbidden area of the stored stroke limit 1.	"
223	When the Z axis was moving in the minus direction, it entered into the forbidden area of the stored stroke limit 1.	"
224	When the Z axis was moving in the plus direction, it entered into the forbidden area of the stored stroke limit 2 or 3.	"
225	When the Z axis was moving in the minus direction, it entered into the forbidden area of the stored stroke limit 2 or 3.	"

(iii) Error on servo system

Number	Content	Remarks
400	The control received the X or Z axis overload signal.	Refer to Item 3.3.3
401	The READY signal (VRDY) of the velocity control has turned off.	"
404	The READY signal (VRDY) of the velocity control does not turn off even though the READY signal (PRDY) of the position control has turned off. The READY signal (VRDY) of the velocity control turns on even though the READY signal (PRDY) of the position control has not yet turned on.	"

Number	Content	Remarks
405	Condition of Reference point signal is not correct when Reference point return is completed.	Refer to Item 3.3.3
406	Servo feedback check detects an error in the position transducer. Alarms 414 and 424 are activated for their respective axes simultaneously with this alarm.	
410	The position deviation value of the X axis exceeds the value allowed while the machine is stopped.	"
411	The position deviation value of the X axis exceeds the value allowed while the machine is moving.	"
412	Drift on X axis is excessive. (Exceeds 500 VELO)	"
413	The content of the error register of the X axis exceeded ± 3276 . Or the velocity command value of the DA converter is out of the range of +8191 ~ -8191. Incorrect settings will cause this alarm.	"
414	Position detection system for resolver/inductosyn method (X axis) is abnormal.	Refer to Item 3.11
415	A feedrate exceeding 511875 detection units/sec. was commanded in the X axis. An incorrect setting of CMR causes this error.	
416	X axis pulse coder position feedback is abnormal. (Disconnection alarm)	
417	X axis servo position LSI is faulty.	
420	The content of the error register of the Z axis is larger than the value allowed while the machine is stopped.	Refer to Item 3.3.3
421	The content of error register of the Z axis is larger than the value allowed while the machine is moving.	"
422	Drift in the Z axis is excessive. (Exceeds 500 VELO)	"
423	The contents of the error register of the Z axis exceeded ± 32767 . Or the velocity command value of the DA converter is out of the range of +8191 ~ -8192. Incorrect settings will cause this alarm.	"
424	Position detection system for resolver/inductosyn method (Z axis) is abnormal.	Refer to Item 3.11
425	A feedrate exceeding 511875 detection units/sec. was commanded in the Z axis. An incorrect setting of CMR causes this error.	
426	Z axis pulse coder position feedback is abnormal (Disconnection alarm)	
427	Z axis servo position LSI is faulty.	

(iv) Error on Connection Unit, MDI & CRT or FANUC PROGRAMMABLE CONTROLLER

Number	Content	Remarks
600	Data transferring error took place in the connection unit .	Refer to Item 3.3.3
601	Slave relay was turned off. [Connection unit PCB or MDI & CRT is faulty or disconnection of cables]	
602	PC program has not yet been loaded. (only FANUC PC-MODEL A)	
603	The correspondence between NC and PC is incorrect or interrupted. Replace FANUC PC-MODEL B PCB (A20B-0008-0440) or Master PCB.	
604	No hold is effective to PC model B-side MPU.	Refer to Item 3.3.3
605	A system error has occurred in FANUC PC-MODEL B side MPU.	"
606	RAM/ROM parity has occurred in FANUC PC-MODEL B side MPU.	"
607	Data transferring error took place in MDI & CRT.	"

(v) Over heat alarm

Number	Content	Remarks
700	Overheat of the main PCB.	Refer to Item 3.3.3
702	Overhead of DC motor.	"

(vi) Errors on memory

Number	Content	Remarks
900	Fault in bubble device (Fault of input signal for bubble device)	Refer to Item 3.3.3
901	Fault in bubble device (The initial point in the bubble was not detected immediately after power on.)	"
902	Fault in bubble device (Page size error, undefined command)	"
903	Fault in bubble device (Transfer missing, Page size over)	"
904	Fault in bubble device (Parity error)	"
905	Fault in bubble device (No marker). Change bubble memory PCB	"
906	Fault in bubble device (Many defect loops)	"
907	A fault occurred in the bubble device (Data cannot be written correctly).	"
908	A fault occurred in the bubble device (Soft parity error).	"
909	A fault occurred in the bubble device (Bubble Device Stop).	"
910	RAM parity error (low byte). Change Master PCB	"
911	RAM parity error (high byte). Change Master PCB	"
912	A fault occurred in the bubble device (Abnormal signal is being issued).	"

Number	Content	Remarks
920	System error (watch dog timer alarm). Change Master PCB	Refer to Item 3.3.3
930	CPU error (0, 3, 4, type interrupt generation). Change Master PCB	"
940	Memory error for offset value (abnormally large offset value set.) Set normal offset value.	"
996	RAM is not mounted although an option which requires an additional RAM is equipped.	"
997	ROM parity error (FANUC PC-MODEL A ROM)	"
998	ROM parity error (Basic ROM)	"
999	ROM parity error (No correspondence between high and low)	"

3.3 Checking and countermeasures

3.3.1 No power can be turned on

Item	Cause	Checking	Countermeasures
1	No input power supply is connected to NC.	① See Sec. 3.4. Make sure that input unit pilot lamp PIL (green LED) is ON.	
		② When PIL is OFF, make sure that input power is supplied at input unit power-supply terminal TP1.	
		③ When power is supplied at TP1 on the input unit and pilot lamp is OFF, see Sec. 3.4. Fuses F1, F2 or F3 is considered blown out.	Remove blowout causes and replace fuses.
2	Alarm lamp is ON.	① See Sec. 3.4. Make sure that input unit alarm lamp ALM (red LED) is OFF. When ON, remove the cause (see Appx. 3 for details) and press POWER OFF button once. Then pressing POWER ON button will power on.	
3	OFF contact of external power-supply ON/OFF is faulty.	Make sure that EOF and COM are shorted at input unit terminal	
4	POWER OFF switch on MDI & CRT unit is faulty.	① Make sure that POWER OFF button contact is closed.	
		② Make sure that two pins \square_{OFF} are shorted in input unit.	
5	POWER ON switch on MDI & CRT unit is faulty.	① Make sure that pressing POWER ON button closes the contact.	
		② Make sure that pressing POWER ON button short circuit two pins \square_{ON} in input unit.	
6	Input unit is faulty.		Replace the input unit.

3.3.2 Operation is not normal after power is turned on

(1) Nothing is displayed on CRT screen

Item	Cause	Checking	Countermeasures
1	Cable connection is erroneous.	1 Made sure that CHX2 of CRT & I/O interface PCB (A20B-0008-0430) and CN1 or CRT unit are connected.	
		2 Make sure that power stabilizing unit (+24V, 0V) and CCP on CRT unit are connected.	

Item	Cause	Checking	Countermeasures
2	LEDs on master PCB light.	See Sect. 2.5	
3	CRT unit is faulty.	See Approx. 7.	
4	CRT & I/O interface PCB (A20B-0008-0430) is faulty.		Replace the PCB.

(2) CRT Becomes No Position Display Screen

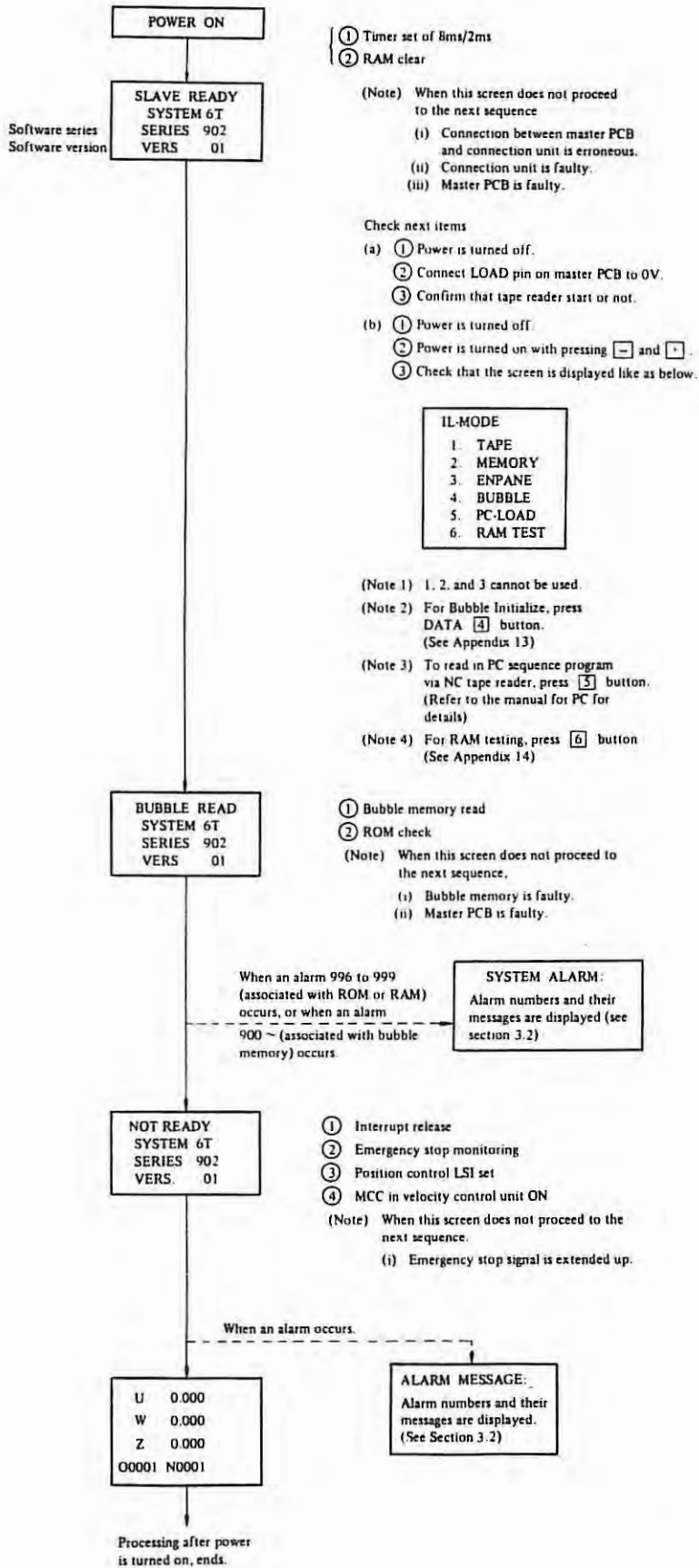

Remedies

- Something (a space symbol, for example) that is ignored by the NC should be punched the before *(EOB) code for odd-numbered holes. The tape punched out by FANUC SYSTEM 6 already is checked TV check.
Number of character in one block is made even number.
- If this lamp lights up with an even number of characters punched, the tape reader may be misreading. So clean the reading section of the tape reader or the nc tape.

(3) Alarm number

070

Memory area insufficient alarm

When the capacity of memory is overflow in storing the NC program, alarm 070 is occurred.

Remedies

- (a) Perform arrangement of memoy, and then store the NC program again

Method of arrangement

- ① Select EDIT mode on the operator's panel.
- ② Release key switch (memory protection key)
- ③ Press [CAN] button
- ④ Press [ORIGIN] button

- (b) If 070 alarm occurred after arrangement, clear the program stored already, and store the new program.

(4) Alarm number

090

Reference point return cannot be performed normally because the one-revolution signal is not input.

091

Reference point return cannot be performed normally because the feedrate is too low.

Using a pulse coder, after turning on the power or resetting the emergency stop, the reference counter is synchronized with the one-revolution signal when the first reference point return is performed. At this time, the following conditions are required to catch the same edge of 1 revolution signal.

- ① The position deviation should be 128 or more.
- ② The one-revolution signal should be input at least once between the time that the axis passes the deceleration dog after position deviation exceeds 128.

If condition A is not satisfied, alarm 91 occurs. If condition B is not satisfied, alarm 90 occurs.

The one-revolution signal is not used during the second or subsequent reference point return, also this alarm check is not made.

Item	Cause of trouble	Troubleshooting	Countermeasures
1	Feedrate is too low.	Perform reference point return under the same conditions in which the alarm occurred, and confirm that the position deviation is 128 or more by using the self-diagnostic function (DGN 800 ~). The start point of the reference point return must not be on the deceleration dog.	Increase the feedrate. When the position gain is 30 sec^{-1} , a feedrate of at least 300 mm/min is necessary.
2	The start point of the reference point return is too close to the reference point.	Check the distance from the start point to the reference point.	The distance from the start point to the reference point must be equivalent to at least two motor revolutions.

Item	Cause of trouble	Troubleshooting	Countermeasure
3	Source voltage for the pulse coder is too low.	When the voltage at power checking terminals on the master PCB is adjusted to $5.0\text{ V} \pm 0.05\text{ V}$, the source voltage of the pulse coder should be 4.75 V or more. (Remove the pulse coder cover and measure the source voltage at the + and - terminals on the pulse coder board.)	Cable loss must be 0.2 V or less. The voltage at the +5 V terminal on the master PCB should be adjusted within the range of 4.95 to 5.10 V.
4	Defective pulse coder	Replace the pulse coder.	Replacement
5	Defective master PCB	Replace the master PCB.	Replacement

(5) Alarm number

210 , 211 , 220 , 221

OT alarm (Over-Travel Alarm)

When the movable member of the machine tool reaches the stroke end, "210" "211" "220" "221" is displayed on the number indicator.

When this alarm occurred, movement of all axes stop in auto operation. In manual mode, axis that alarm occurred stops.

Two limit switches (LS1, LS2) are provided on each axis in each direction (+X, -X, +Z, -Z) as shown in the figure below, to stop the movable member of the machine tool.

For details, refer to the operator's manual published by the machine tool builder. This figure is an example.

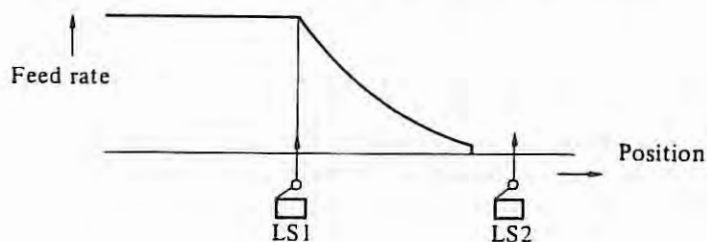

- When LS1 operates, the feed is stopped after deceleration. 210, 211, 220 or 221 is displayed
- When LS2 operates, the feed is emergency stopped. (LS2 operates only when LS1 malfunctions)

Causes and Remedies

- ① If the reference point setting is error, correct the program.
- ② If the program is error, correct the program.

Release

- (a) When only LS1 operates
Move the movable member of the machine tool by manual operation (Jog, Step or Handle) in the opposite direction (safe side) to separate it from the limit switch, and then push the RESET key on the MDI & CRT panel.

(Note) In this case, the movable member of the machine tool can be moved only in the opposite direction.

- (b) When both LS1 and LS2 operate
 - (i) Set 2nd L.S. REMOVE button to ON on operator's panel.
 - (ii) Do the same operation as in releasing LS1.

(Note) In the equipment in which LS1 is not in operation when LS2 is in operation, the movable member is movable in both directions by manual operation. Be careful of the direction in which it is to be moved. LS1 has malfunctioned.

(6) Alarm number

212 ~ 215, 222 ~ 225

Stored Stroke limit alarm

When machine reached stored stroke limit, 212 ~ 215, or 222 ~ 225 is displayed on indicator. When this alarm occurred, movement of all axes stop in auto operation. In manual mode, axis that alarm occurred stops.

Causes

- (a) Program miss.
- (b) Setting of stored stroke limit is abnormal.

Confirm

Check the actual machine position by DGN 820, 821
Distance from the reference point in the X and Z axes in this order.

8	2	0
---	---	---

ABSMTX

8	2	1
---	---	---

ABSMTZ

Remedies

- (a) Correct program
- (b) Set stored stroke limit again

Release

- (a) Machine can be moved to only reverse direction of overtraveled direction.
- (b) Press emergency stop button and release alarm, then input G23 (stored stroke limit OFF) from MDI and move machine by JOG to go out from inhibited area.

(7) Alarm number

400 , 402 overload alarm

Item	Cause of trouble	Check procedure	Countermeasured
1	Confirmation	This alarm occurs in heavy cutting.	Power must be turned off for 30 minutes and press the reset button. See 2 or 7.
		This alarm occurs at power on.	Confirm the connection. See 4.
		This alarm occurs even short the S21 (for H series), S20 (for M series) on velocity control unit.	See 2.
		This alarm does not occur when short the S21 (for H series), S20 (for M series) on velocity control unit.	See 7.
2	Overload	Check the motor current of trouble axis. 0.5 continuous rated current 12A 10 continuous rated current 27A 20, 30, 10H " 33A	Reduce cutting condition. Measure the motor current in the low idling feed. If the current is close to the rated current of motor, readjust the machine.
3	Improper setting of thermal relay.	Check whether setting is correct or not according to above value.	Reset the setting.
4	Connecting trouble	Check the connecting of overload signal (OVL) between CAV on the master PCB and CN1 on the velocity control PCB. Check contactor of the thermal relay.	Refer to item 3.9.
5	Thermal relay trouble	Check whether trouble condition is reset or not by reset button.	Replace the thermal relay.
6	Trouble in master master PCB		Replace the thermal relay.
7	Overload of transformer	Check the resistance between terminal 51 and 52 i) Resistance is 0. (contact is close) ii) Resistance is infinity (contact is open)	Power must be turned off for 30 minutes, then press the reset button or connection trouble between thermal relay and CN2 on the velocity control unit. Thermostat is trouble. Replace a transformer.

(8) Alarm numbers

401 , 403 READY signal (VRDY) of velocity control unit is turned off.

Item	Cause of trouble	Check procedure	Countermeasures
1	Fault analysis	* Check if green LED PRDY lights in velocity control unit PCB.	Proceed to 2 when LED PRDY lights. Proceed to 8, when it does not light.
2	Fault analysis	Check if alarm LED lights in velocity control unit PCB.	If this LED lights, locate and eliminate a cause of alarm (See (a) ~ (g)). Proceed to 3, when this LED does not light.
3	Fault analysis	Check if green LED VRDY lights in velocity control unit PCB.	Proceed to 8 when VRDY LED lights. Proceed to 4 when it does not light.
4	Fault analysis	Check if electromagnetic contactor MCC is turned on in velocity control unit.	Proceed to 9 when MCC is turned on. Proceed to 5 when it is not turned on.
5	Fault analysis	Check if 100V is applied across terminals (3) and (4) of terminal board T1 of velocity control unit.	Proceed to 7 when power is applied. Proceed to 6, if not applied.
6	Signals from machine tool	Check 100V power supply. Check if emergency stop signal is sent from machine tool or if the machine tool is ready for operation.	Restore to normal conditions.
7	Trouble in velocity control unit	Velocity control unit PCB or MCC is defective.	Replace.
8	Poor contact	Poor contact between velocity control and master PCB, or a trouble in master PCB.	Replace.
9	Poor contact	Poor contact inside velocity control unit or a trouble in velocity control unit PCB.	Replace.

(a) TGLS alarm

Item.	Cause of trouble	Check procedure	Countermeasures
1	The motor power cable is not connected to terminals (5), (6), (7) or (8) of terminal board T1 in the velocity control unit, or the power cable is broken.	If the TGLS alarm indicator goes on when a motion command is not input, the alarm cause described at the left should be checked.	Check the power cable connection.
2	PCB setting is improper.	Check the setting according to section 3.1.	Adjust the setting.
3	Velocity feedback voltage is not being applied or is intermittent.	Measure the velocity feedback voltage between check terminals CH2 (TSA) and CH3 (GND) with an oscilloscope. Confirm whether the voltage is being interrupted.	Repair the cable carrying the velocity feedback voltage. Repair the defective source (i.e., motor or control) of the velocity feedback voltage.

(b) OVC alarm

Item	Cause of trouble	Check procedure	Countermeasures
1	PCB is defective.	The OVC alarm indicator goes on if the power is turned on when the motor power cable is disconnected. (In this case, since the drive axis may fall down, it should be supported. The S23 terminal should be shorted so that the TGLS alarm indicator will not go on. After confirmation, the S23 connection should be opened.)	Replace the PCB.
2	PCB setting is improper.	Check the setting of variable resistor RV3 which is used to set the upper limit of the motor current (see section 3.1). (Generally, RV3 is set to 10, but the adjustment may differ with the machine tool.)	Change the RV3 setting.
3	Mechanical load is abnormal.	Observe the waveform between check terminals CH8 and CH3 with an oscilloscope. Check whether the current which is determined by RV3 flows for more than 600 msec or not.	Alleviate the mechanical overload.

(c) BRK alarm

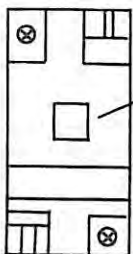
Item	Cause of trouble	Check Procedure	Countermeasures
1	The circuit breaker operated.	<p>The breaker is open when it is as shown below. See section 5.4 for the location of the breaker.</p>  <p>This button pops up when the breaker operates. To reset the breaker, press the button after turning off the power.</p>	Turn off power and reset the breaker. It cannot be reset immediately, wait about ten minutes and try again.)
2	Diode module DS or some other part of the velocity control unit is defective.	The breaker operates again when power is restored after the countermeasures of item 1.	Replace diode module DS or the whole velocity control unit.
3	Mechanical load is excessive.	Observe the motor load current between terminals CH8 and CH3 on the PCB with an oscilloscope. Check whether it exceeds the rated current.	Alleviate the mechanical overload.
4	The PCB or the connection between the PCB and the velocity control unit is defective.	The BRK alarm occurs when the circuit breaker is not operating.	Replace the PC board or the velocity control unit.

(d) HVAL alarm

Item	Cause of trouble	Check Procedure	Countermeasures
1	The AC input power source voltage is too high.	Check the tap connection on the servo power transformer.	Change the tap connection.
2	The servo motor is defective.	Check the insulation resistance between the armature and the motor body.	Clean the brushes and commutator.
3	PCB is defective.	The HVAL alarm indicator is on although no trouble is found in items 1 and 2 above.	Replace the PCB.

(e) LVAL alarm

Item	Cause of trouble	Check procedure	Countermeasures
1	The AC input power source voltage is too low.	Check whether the wires for the AC input power source are connected to the correct taps on the servo transformer.	Change the tap connection.
2	The connection between the servo transformer and CN2 on PCB is defective.	Check the PCB control voltage (+24V and $\pm 15V$). (See Section 3.1.) Check the connection between the servo transformer terminals 41 through 43, 44 through 46, and 47 through 49 and the CN2 on PCB. (See Section 2.3.2.)	Change the connection.
3	The PCB is defective.	The LVAL alarm indicator is on although no trouble is found in items 1 and 2 above.	Replace the PC board.

(f) HVAL alarm

Item	Cause of trouble	Check procedure	Countermeasures							
1	Improper motor power cable connection.	The HVAL alarm indicator does not go on when the power is turned on with the motor power cable is disconnected. (In this case, since the gravity axis may fall down, it should be supported. The S23 terminal on the PCB should be shorted so that the TGLS alarm indicator will not go on. The S23 connection should be opened after confirmation.)	Fix the motor power cable connection.							
2	The transistor module is defective.	The HVAL alarm indicator goes on when the motor power cable is disconnected. Turn off power and measure the resistance between the following terminals using a multi meter. If the measured value is 10 ohms or less, the transistor module is defective.	Replace the transistor module. <table border="1" style="margin-left: auto; margin-right: auto;"> <tr><td>o</td></tr> <tr><td>C1</td></tr> <tr><td>B1</td></tr> <tr><td>E1, C2</td></tr> <tr><td>B2</td></tr> <tr><td>E2</td></tr> <tr><td>o</td></tr> </table> <p style="text-align: center;">Confirm between C1-E1, C2. E1, C2-E2.</p>	o	C1	B1	E1, C2	B2	E2	o
o										
C1										
B1										
E1, C2										
B2										
E2										
o										

(g) DCAL alarm

Item	Cause of trouble	Check procedure	Countermeasures
1	Transistor Q1 or the PCB is defective.	The DCAL alarm indicator goes on immediately after turning on power.	Replace transistor Q1. Replace PCB.
2	PCB setting is improper.	Terminal S26 is shorted although the separate regenerative discharge unit is used with the gravity axis.	Open terminal S26.
3	Machine tool counterbalance is improper.	The waveform shown in Section 3.1 Fig. 3 is measured at stated periods on check terminal CH10 while the counterbalanced axis is moving down at rapid travers speed.	Adjust the counterbalance.
4	The acceleration/deceleration rate is too high.	Check whether the positioning rate at rapid traverse speed exceeds 1 to 2 times per second. Check that this alarm indicator does not go on when the rate is decreased.	Use a dwell period and decrease the acceleration/deceleration rate.

(9) Alarm number

404 Velocity control READY signal (VRDY) is on even if READY signal (PRDY) in position control is on.

Item	Cause	Checking	Countermeasures
1	Confirmation	1 Turn OFF NC power supply. 2 Remove motor power line or motor. 3 Make setting pin S20 (for H series), S23 (for M series) on servo amplifier open. 4 Turn ON NC power supply.	Refer to Item 6.2.
		A MCC on Servo amplifier is OFF (see Item 3.8.3 for details).	Proceed to 2.
		A MCC Servo amplifier is ON.	Proceed to 5.
2	Ditto	1 Turn OFF NC power supply. 2 Remove cable-J50 master PCB-side connector (CAB). 3 Turn ON NC power supply.	
		No alarm 404 occurs.	Proceed to 3.
		Alarm 404 occurs.	Proceed to 4.
3	Cable J50 is faulty.	Check the cable for connection (see Sec. 3.9)	Proceed to 5.
4	Master PCB is faulty.		Replace the PCB.
5	Servo amplifier is faulty.		Replace the servo amplifier.

(10) Alarm number

405 Reference Point Return motion is not good. (Refer to item 3.15)

Item	Cause of trouble	Check procedure	Countermeasures
1	X and Z axes		Replace the Master PCB.

(11) Alarm number

410 , 411 , 420 , 421 Position deviation excessive alarm

Item	Cause of trouble	Check procedure	Countermeasures
1	Miss setting of allowable error	Check parameter 074 ~ 105.	Correct the setting. Refer to adjustment of position control.
2	Overshoot	When enough current does not flow to motor in acceleration or deceleration, deviation value increase. Check waveform of CH1 on velocity control PCB and confirm whether overshoot is within 5% or not.	Increase the rapid traverse time constant. Increase gain (RV1) of velocity control. (Refer to Item 6.2)
3	Miss setting the secondary voltage of power transformer	Check whether the secondary voltage of power transformer is correct. Model 0 60V Model 5, 10 90V Model 10, 20, 30, 10H . . 120V	Reset the setting. (Refer to Item 4.2)
4	Drop of input power voltage	Check that input power voltage is within $\pm 10\%$ and -15%	Change the input tape of power transformer for servo. (Refer to Item 4.2)
5	Voltage of power supply is abnormal	Check the voltage of control part.	Repair the fault.
6	Connection trouble	Check the power line of motor, tacho-generator signal, resolver signal, inductosyn signal etc.	Repair the fault.
7	Trouble in position control section in master PCB or/and velocity control unit	Check the trouble by changing when there is spair PCB.	Replace the PCB with spair one. (Refer to Item 6.1)

(12) Alarm number

412 , 422 Drift excessive alarm

Item	Cause of trouble	Check procedure	Countermeasured
①	Connection trouble	Check the connection of power wires to servo motor. Check the connection between position detector and servo motor.	Repair the fault.
②	Setting miss of drift compensation value	Check whether the contents of parameter No. 124, 125 exceed 500 or not.	In emergency stop on condition, set 7th bit (ADFT) of parameter number $\overline{006}$ to '0' and set the contents of parameter No. $\overline{124}$, $\overline{125}$ to '0', And then reset ADFT to "1" and release the emergency stop.
③	Trouble in velocity control unit or/and position control circuit	Check the trouble by changing when there is spair PCB	Replace the PCB with spair one.

(13) Alarm number

413 , 423 Abnormal velocity command value.

These alarms occur when:

- (1) Positional deviation in the axis involved exceeds ± 3276.7 . When, however, positional deviation limits (parameters 074 ~ 075) at stoppage or those (parameters 078 ~ 079) during motion are set correctly, alarm 410, 420 is displayed before any of the above-noted alarms. So they usually cannot occur on this condition.
- (2) D/A converter velocity command value is without the range of +8191 to -8192.
D/A converter velocity command value = $0.192 \times K \times G \times E \times 10^{-6}$

where K : servo loop gain multiplier (parameters 086, 087)

G : servo loop gain 0.01 sec^{-1} (parameter 090)

E : position deviation

Can be verified by DGN 800 in X.

Can be verified by DGN 801 in Z.

Theoretical value (when feed has become constant)

$$E = \frac{F}{60} \times \frac{1}{G} \times \frac{1}{\alpha} \times 10^2$$

where F : feed rate mm/min (inch/min)

α : detection unit mm (inch)

G : servo loop gain 0.01 sec^{-1}

Item	Cause	Checking	Countermeasures
1	Parameter setting is erroneous.	1) Check servo loop gain multiplier. Parameters 086 ~ 087 2) Check servo loop gain. Parameter 090 3) Check CMR. Parameters 027 ~ 028 4) Check DMR. Parameters 014 ~ 015	
2	Positional deviation is great.	Compare theoretically calculated value with the following, by DGN 800 in X. by DGN 801 in Z. 1) Feed rate Rapid traverse rate: parameters 092~093.	
		Feed rate is right; positional deviation is also right.	Proceed to (6).
		Feed rate is right; positional deviation is not right.	Proceed to (3).
3	Machine tool does not move by a normal distance.	Issue a command (feed of several mm) causing no alarm to check if machine tool moves by a normal value.	
		Machine tool does not move by a normal value.	Proceed to (4).
		Machine tool moves by a normal value.	Proceed to (5).
4	Position detector is faulty.		Replace the position detector.
5	PCB is faulty.		For pulse coder, replace master PCB. For resolver/inductosyn, replace PCB A20B-0008-0461.
6	Master PCB is faulty.		Replace the master PCB.

(14) Alarm number

414 , 424 Position detecting system trouble. (Resolver/inducosyn)

Item	Cause	Checking	Countermeasures
1	Connection is faulty.	Check connector connection and cable signal line connection. Check if the signal line is shorted to the ground or to another line.	Repair erroneous connection.
2	Detected gain is not good.	See Item 6.1.6 for detected gain adjustment.	Adjust detected gain.
3	Phase shift is not good.	Check if phase shift value was initialized (parameter 013, bit 4, PHS = 0) at first field adjustment or after position detector replacement.	Initialize phase shift value.
4	PCB setting is erroneous.	Check inductosyn/resolver interface PCB for shorting. See Item 6.1.7 for alarms 414, 424.	Correct erroneous setting.
5	Parameter setting is erroneous.	Check if Resolver/Inducosyn parameters DSCGX, Z (parameter 316, bits 0-1) are set to 1 for pulse coder-type position detection.	Set parameters correctly.
6	PCB adjustment is not good.	Check Fmin and Fmax adjustment on inductosyn/resolver interface PCB (see Item 6.1.6).	Adjust again.
7	Position detector is faulty.	Change fault axis to another axis for checking.	Replace the position detector.
8	Inducosyn gap is clogged with chips.	Insert a piece of paper in the gap. Check if scale-side signal and slider-side signal are insulated with NC-side cable removed.	Remove chips.
9	Inducosyn/resolver interface PCB is faulty.	Replace the PCB for checking.	Replace the PCB. A20B-0008-0461
10	Inducosyn pre-amplifier is faulty.	Replace the preamplifier for checking.	Replace the pre-amplifier.
11	Master PCB is faulty.	Replace the PCB for checking.	Replace the PCB.

(15) Alarm number

416 , 426 (Disconnection Alarms)

Item	Cause	Checking	Countermeasures
1	Cable connection is erroneous.	Check pulse-coder signals by DGN 713 and pulse-coder feedback cable connection and wiring.	
2	PCB is faulty.	Check master PCB in X and Z axes.	Replace the Master P.C.B.
3	Pulse coder is faulty.		Replace the pulse coder.

(16) Alarm number

600 : Data Transfer error from Connection Unit.

Item	Cause	Checking	Countermeasures
1	Cable connection is erroneous.	Check cable connection and wiring.	
2	Connection unit is faulty.		Replace the PCB.
3	Master PCB is faulty.		Replace the PCB.
4	MDI & CRT unit is faulty.		Replace the unit.
5	Terminator unit is faulty.	Check the terminator unit at the end of serial transfer line (Honda's 20-pin connector) for contact.	Replace the unit

(17) Alarm number

604 , 605 : FANUC PC-MODEL B PCB Is Faulty .

Item	Cause	Checking	Countermeasures
1	PCB A20B-0008-0440 is faulty.	Make sure that PCB setscrews are fastened.	Replace the PCB.
2	Master PCB is faulty.		Replace the PCB.
3	Other troubles	Inform FANUC Service Center of DGN 158/159 data.	

(18) Alarm number

606

(1) FANUC PC-MODEL B ROM faulty

ALARM MESSAGE: 606 ROM

(2) FANUC PC-MODEL B RAM (HIGH BYTE) Faulty

ALARM MESSAGE: 606 RAM HIGH

(3) FANUC PC-MODEL B RAM (LOW BYTE) Faulty

ALARM MESSAGE

606 RAM LOW

Item	Cause	Checking	Countermeasures
1	ROM is faulty.	Check DGN 160/161 data.	Inform FANUC Service Center. Replace PCB A20B-0008-0440.
2	RAM is faulty.		

(19) Alarm number

607 Data Transfer error from MDI & CRT Countermeasured

Item	Cause	Checking	Countermeasures
1	Cable connection is erroneous.	Check cable connection and wiring.	
2	MDI & CRT unit is faulty.		Replace the unit.
3	Master PCB is faulty.		Replace the PCB.
4	Connection unit is faulty.		Replace the PCB.
5	Terminator unit is faulty.	Check the terminator unit (Honda's 20-pin connector) at the end of serial transfer line for contact.	Replace the unit.

(20) Alarm number

700

Over-Heat Alarm

"700" is displayed on the number indicator when the overheat of the control unit is detected.

Release

While this alarm is displayed, restart is impossible with reset button.

After the temperature is lowered, the alarm release.

Item	Cause of trouble	Countermeasures
①	Ambient temperature too high.	Lower ambient temperature.
②	Air filter is too dusty.	Clean the air filter.
③	Motor Fan trouble	Replace the motor fan.

(21) Alarm number

702

Overheat alarm of DC servo motor

Item	Cause of trouble	Check procedure	Countermeasures
1	Overload	Check that the motor armature current exceed the rated current.	Decrease load torque. Decrease cutting duty.
2	Winding insulation trouble	Check the insulation between motor power the terminals A1 or A2 and the motor bodys with a tester or a megger. Over 1M Ω at 500V is normal for the megger check. Infinite value is normal in the tester check.	Clean around the commutator with forced air. Change the motor if the above counter-measure is ineffective.
3	Shortcircuit in internal winding	Measure no-load current by removing the motor from the machine. If the current increases in proportion to the motor rotation rate, there is a short-circuit in an internal winding.	Clean around the commutator. The oil adheres to the surface of the commutator, this problem can easily occur.
4	Field system magnet demagnetization	Check that voltage is normal by measuring the motor terminal voltage between terminals A1 and A2.	Change the motor if terminal voltage is low or the motor is overheated.
5	Trouble in heat pipe fan operation	Check the fan voltage or the wiring. Check whether the fan touches a wire gauze. Check the fan motor	Rearrange the wiring. Refix the wire gauze. Replace the fan motor.
6	Trouble in heat pipe efficiency	The heat pipe is ineffective the attached motor is over heated, despite that all the above items concerning the trouble in the heat pipe fan operation are normal.	Replace the motor.
7	Brake trouble	Check that the brake connection corresponds to the power source frequency. Check that the voltage is 100V \pm 10% (allowable value).	Replace the brake.
8	Connection trouble	Check whether a motor signal line is disconnected or a connector is loose. (Refer to Item 3.10.)	Repair the fault.
9	Master PCB and/or additional axis control PCB is fault		Replace the PCB.

(22) Alarm number

900 ~ 909 , 912 Bubble memory alarm

The CRT displays the alarm number

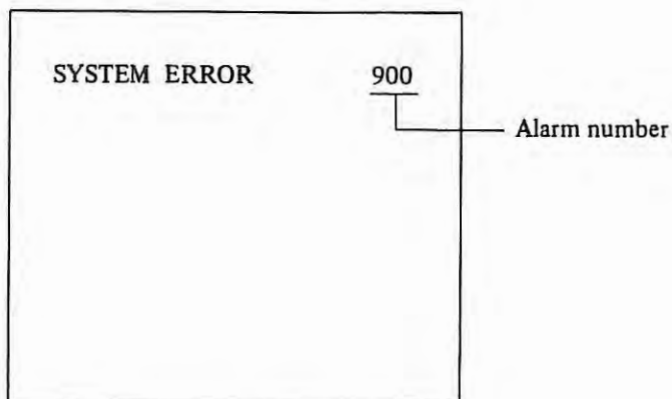

Please contact with the FANUC Service Center.
Refer to appendix 13 Bubble Memory Initialize for alarm 901 , 905 and 906 .

(23) Alarm number

910 , 911 RAM parity alarm

The CRT displays the alarm number

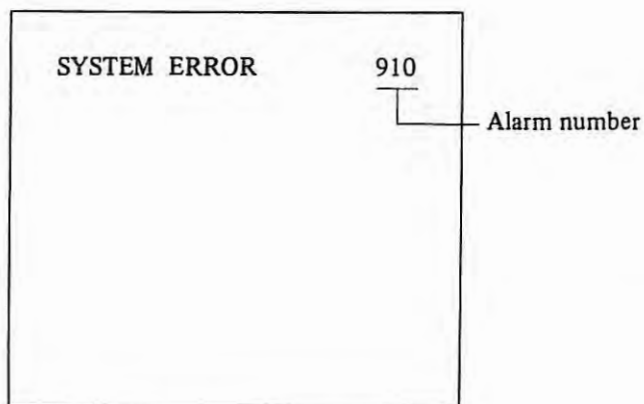

Please contact with the FANUC Service Center.

Item	Cause of trouble	Check procedure	Countermeasures
①	Master PCB is faulty.		Replace the PCB.
②	Other troubles	See Appx. 14 to conduct RAM test.	

(24) Alarm number

920 System error (watch dog timer alarm)

Item	Cause of trouble	Check procedure	Countermeasures
1	Setting miss of parameter number 000 to 004 and 300 to 304	Refer to data sheet.	Clear the all parameter and reset it. Method of clear ① Set parameter enable switch to ENABLE side. ② Power on with pressing CAN and DELET Refer to item 5.3 about parameter. Offset amount and setting is also cleared. It is need to reset it.
2	Master PCB trouble	Change PCB if there is spare PCB. Check whether setting and adjustment of PCB are performed or not	Replace the PCB

(25) Alarm number

930 CPU error alarm

Unused type interrupt is occurred by some causes **930** alarm will occur.

Remedies

- Change PCB if there is spare PCB. Check whether setting and adjustment of PCB are performed or not.
- Please contact with FANUC service center.

(26) Alarm number

940 Memory alarm of offset amount

When initial setting amount of offset exceeds ± 999.999 mm, this alarm will occur.

Remedies

- Clear the offset amount and reset the normal amount.

Method of clear

- ① Set parameter enable switch to ENABLE side.
- ② Power on with pressing **CAN** and **DELET**

In this case parameters are also cleared.

It is need to reset it.

(27) Alarm number

960 system error

Master PCB or bubble memory PCB is trouble. Change PCB if there is spare PCB. Then setting and adjustment on the master PCB must be performed correctly.

(28) Alarm number

996 Additional RAM installation error

Alarm number 996 appears on CRT.

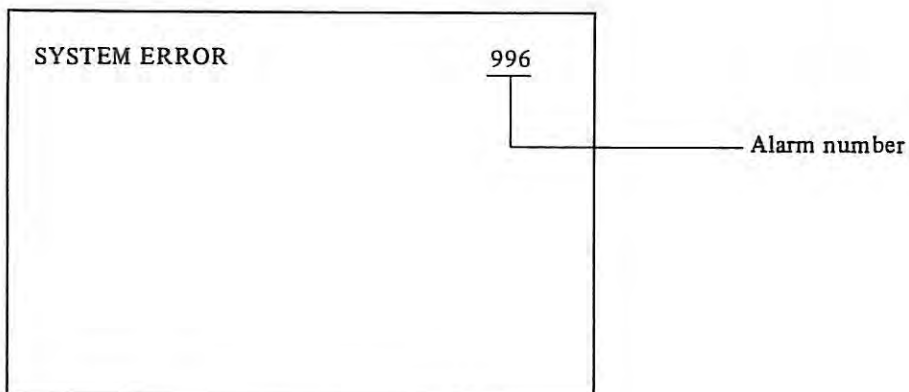

Item	Cause of trouble	Check procedure	Countermeasures
1	Additional RAM is not mounted irrespectively of the additional of an option which requires an additional RAM.	Additional RAM has not been mounted after replacing the master PCB.	Mount additional RAM.
		An option parameter requiring additional RAM is set by mistake.	Clear all parameters and reset them.
		Additional RAM is defective.	Replace.

(29) Alarm number

997 FANUC PC-MODEL A ROM parity error

The CRT displays the alarm number and the number of ROM the error occurred on.

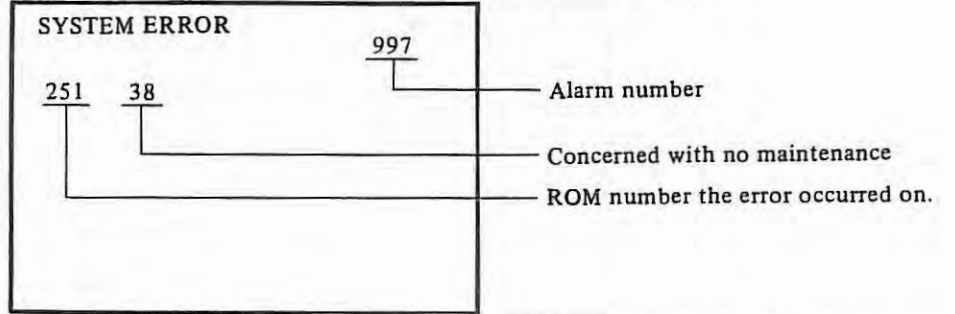

ROM numbers and positions ROMs are mounted at, correspond to each other as in the figure below.

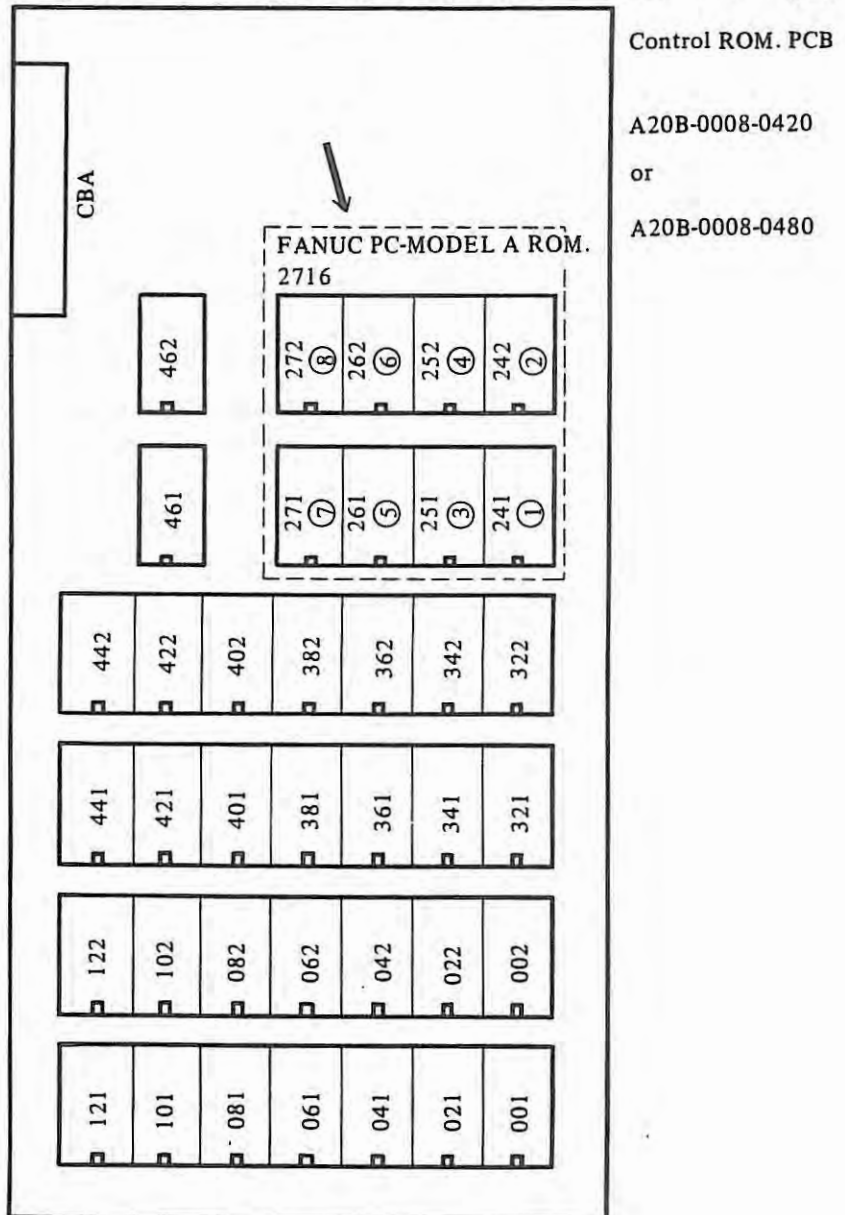

Countermeasures) Inform FANUC Service Center of the alarm number and the number of EROM the error occurred on.

(30) Alarm number

998 Basic ROM parity alarm

The CRT displays the alarm number and the number of ROM the error occurred on.

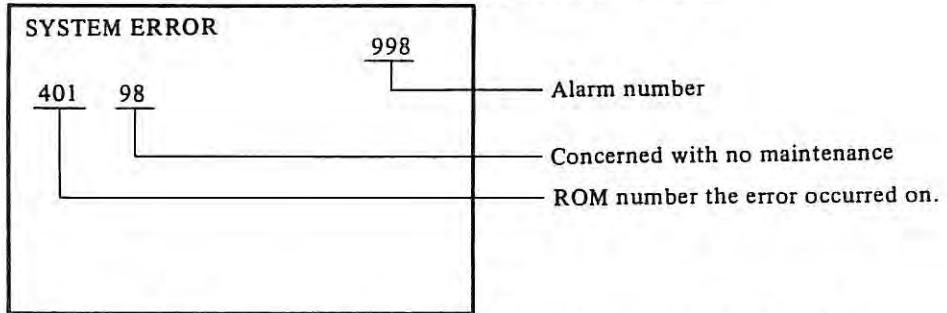

ROM numbers and positions ROMs are mounted at, correspond to each other as in the figure below.

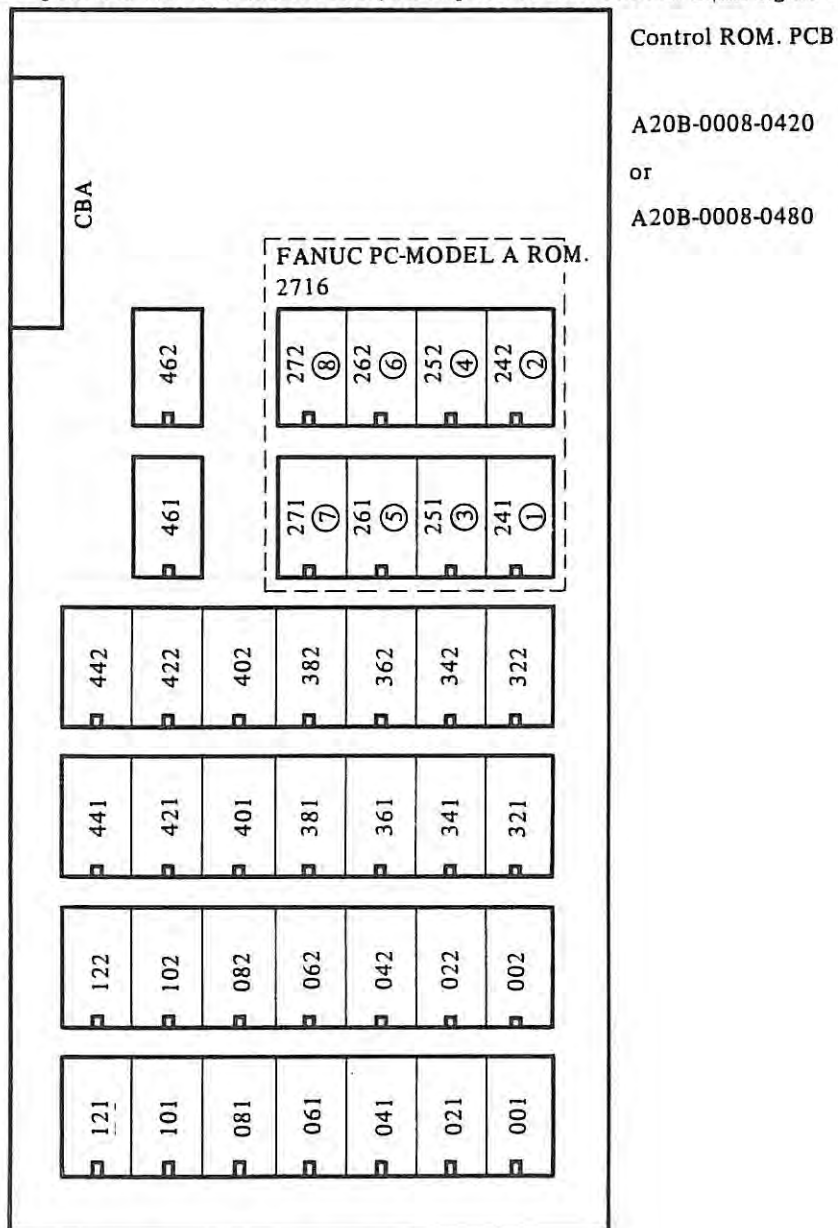

Countermeasures) Inform the alarm number, the number of EROM the error occurred on, software series and software version according to item 3.3.2 to FANUC Service Center.

- (31) Alarm number
 999 ROM pair error

The CRT displays the alarm number and the number of ROM the error occurred on.

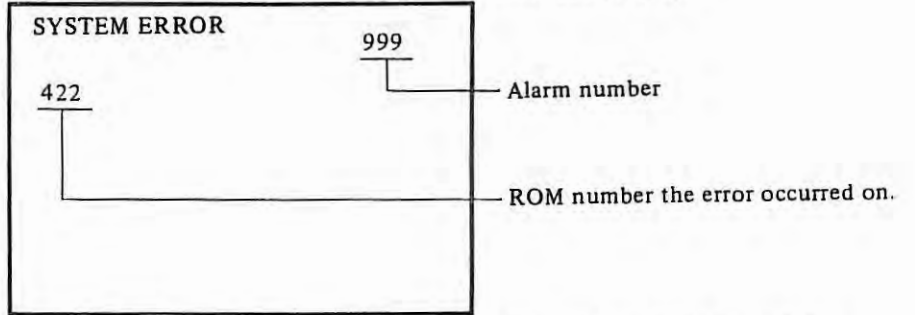

ROM numbers and positions ROMs are mounted at, correspond to each other as in the figure below.

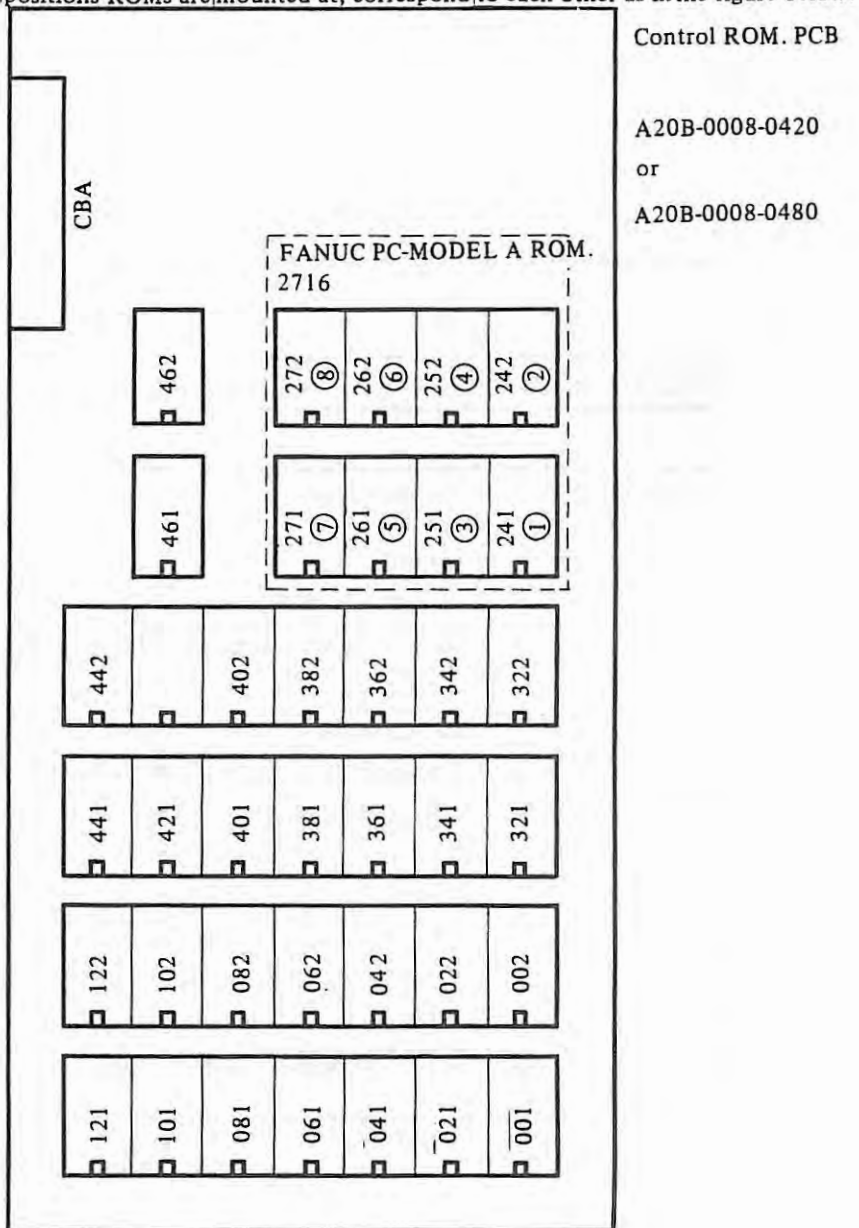

Countermeasures) Inform the alarm number, the number of EROM the error occurred on, software series and software version according to item 3.3.2 to FANUC Service Center.

3.3.4 LEDs on the master PCB light

When an alarm occurs, usually the CRT display the alarm number, but in some cases it cannot display alarms for troubles associated with display functions. In such cases, the LEDs on the master PCB are made to display the alarm contents as in the figure below.

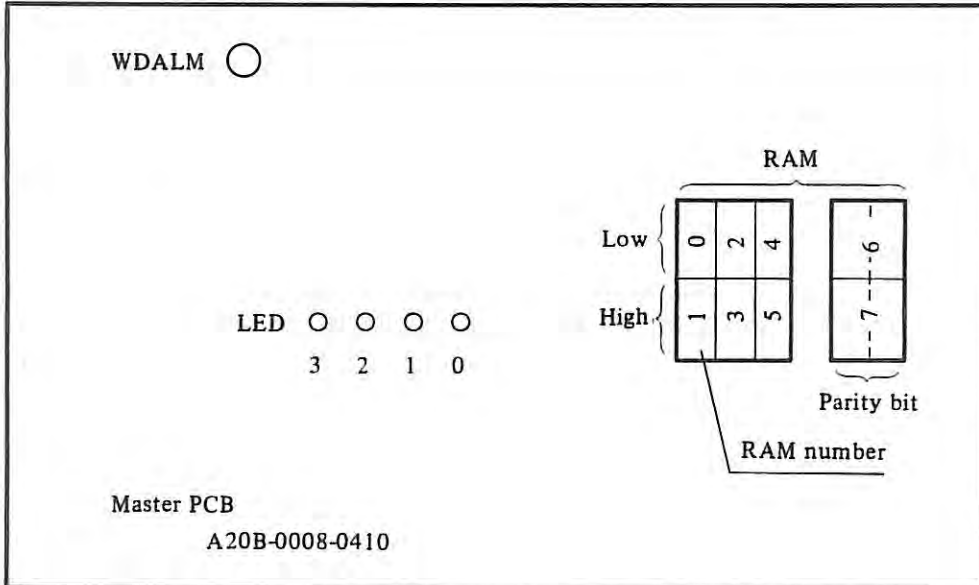

WDALM lights	Watch Dog Alarm	See alarm No. 920.
--------------	-----------------	--------------------

LEDs 3 2 1 0	Alarm contents	
x x x x	Normal	
x x x o	Slave Ready is OFF.	See alarm No. 601.
x x o x	Alarm 900-999 (except 910, 911)	
x o x x	RAM parity alarm (Note)	See Appx. 14.
o x x x	RAM test shows RAM of No. 0 is faulty.	See Appx. 14.
o x x o	RAM test shows RAM of No. 1 is faulty.	See Appx. 14.
o x o x	RAM test shows RAM of No. 2 is faulty.	See Appx. 14.
o x o o	RAM test shows RAM of No. 3 is faulty.	See Appx. 14.
o o x x	RAM test shows RAM of No. 4 is faulty.	See Appx. 14.
o o x o	RAM test shows RAM of No. 5 is faulty.	See Appx. 14.
o o o x	RAM test shows RAM of No. 6 is faulty.	See Appx. 14.
o o o o	RAM test shows RAM of No. 7 is faulty.	See Appx. 14.
<div style="display: inline-block; border: 1px solid black; width: 10px; height: 10px; margin-right: 5px;"></div> Flickering x x x	RAM Test Wait or RAM Test End	

o : ON x : OFF

3.3.5 Jog operation is impossible

Item	Cause	Checking	Countermeasures
1	Confirmation	Check if position display changes in DLK OFF state. (display lock)	
		① Position display changes, but machine tool does not.	Proceed to 2 .
		② Neither position display nor machine tool moves.	Proceed to 5 .
2	MLK ON (Machine lock)	Make sure that Bit 7 of DGN 100 is 0.	
3	Parameter setting is erroneous	Make sure that bit 5th of parameter 005 is 0.	
4	Servo system is abnormal.	See Item 3.11.	
5	Parameter setting is erroneous	Make sure that bit 6th of parameter 005 is 0.	
6	No mode signal has been input.	Check DGN 105 to make sure that only Jog mode signal is 1.	“
7	No axis selection signal (+X, -X, ...) has been input.	Make sure that DGN 96 ~ axis selection signal is input. Note: When axis command is input before J mode is selected, the axis does not move. Cutting the axis command once, then inputting it again, moves the axis.	“
8	Jog feed rate setting is erroneous.	Check parameter 91. When no rapid traverse is effected, check rapid traverse rate parameter 92 ~ .	
9	External reset ERS ON	Make sure that bit 7 of DGN 102 is 0.	Confirm the connection.
10	Reference Point Return (ZRN) ON	Make sure that bit 7 of DGN 101 is 0.	“
11	LEDs on master PCB	See Item 3.3.4.	Replace the master PCB.

3.3.6 Manual pulse generator does not operate

Item	Cause	Checking	Countermeasures
1	Confirmation	Check if position display changes in display lock DLK OFF state.	
		① Position display changes, but machine tool does not move.	Proceed to 2 .
		② Neither position display nor machine tool moves.	Proceed to 5 .
2	Machine lock MLK ON	Make sure that bit 7 of DGN 100 is 0.	
3	Parameter setting is erroneous	Make sure that bit 5th of parameter 005 is "0".	
4	Servo system is abnormal.	See Item 3.11.	
5	Fixed parameter setting is erroneous.	Collate parameters 000 ~ 004 with the parameter table accompanying the NC.	
6	Parameter setting is erroneous	Make sure that bit 6th of parameter 005 is "0".	
7	No mode signal has been input.	Check DGN 105 to make sure that only Handle mode signal is 1.	
8	No axis/selection signal HX/Z has been input.	Make sure that DGN 96/ axis selection signal is input.	
9	External reset ERS ON	Make sure that bit 7 of DGN 102 is 0.	
10	Reference Point Return (ZRN) ON	Make sure that bit 7 of DGN 101 is 0.	
11	Manual pulse generator is faulty.	Make sure that turning the manual pulse generator turns ON/OFF bits 5 (*HB) and 4 (*HA) of DGN 714.	
12	LEDs on master PCB light.	See Item 3.3.4.	

3.3.7 Synchronous feed or feed per revolution is no good.

Item	Cause	Checking	Countermeasures
1	Cable connection is erroneous.	Check NC and position coder for inter-connection.	
2	Number of spindle revolutions	<p>Check the number of spindle revolutions displayed on CRT for coincidence with the then number of actual spindle revolutions.</p> <p>[Displaying the number of spindle revolutions]:</p> <p>① Press COMND button.</p> <p>② Keep pressing PAGE button until CURRENT BLOCK screen appears.</p> <p>③ CURRENT BLOCK screen will display the number of spindle revolutions in SACT <input type="text"/> <input type="text"/> <input type="text"/> <input type="text"/></p> <p>Note: The number of spindle revolutions is displayed by counting feedback signals from the position coder.</p>	
3	Master PCB setting is erroneous.	See Item 6.1 to check setting.	
4	Position coder is faulty.		Replace the position coder.
5	Master PCB is faulty.		Replace the master PCB.

3.3.8 Tape reader does not operate normally

Item	Cause	Checking	Countermeasures
1	Confirmation	① Pressing START button in tape mode, does not feed tape.	Proceed to 3 .
		② Pressing START button in tape mode, feeds tape but reads in no data normally.	Proceed to 10 .
		③ Pressing READ button in memory mode, does not feed tape.	Proceed to 2 .
		④ Pressing READ button in memory mode, feeds tape but reads in no data normally.	Proceed to 10 .
2	Setting is erroneous.	Let CRT be SETTING DATA 01 screen to make sure INPUT DEVICE 1 = 0 INPUT DEVICE 2 = 0 Operation: ① Press SET button. ② Keep pressing PAGE button until SETTING DATA 01 appears.	
3	No mode signal has been input.	Check DGN 105 to make sure that only MEM in memory mode or T in tape mode is 1	
4	Tape reader status display	Check DGN 703 to make sure that bits 4 and 6 are 1. Bit 4 is 1 when the toggle switch in tape reader is ready for automatic operation.	Check master PCB and tape reader for interconnection.
5	No start signal has been input (tape mode only).	Check DGN 101 to make sure that turning ON/OFF START button, makes bit 2 1/0.	
6	READ button is faulty (memory mode only).	It is difficult to directly check this signal. Therefore, indirectly check by seeing whether or not pressing START button in tape mode, feeds tape.	
		Tape is fed in tape mode.	READ button is faulty.
		Tape is not fed in tape mode.	Proceed to 7 .
7	No tape reader AC power is supplied.	Check whether or not tape reader motor is revolving. When not, no AC power is supplied.	
8	No tape reader DC power is supplied (+24V, +5V, 0V).	Turn the switch in tape reader to MANUAL to check if tape is fed. If not, check DC power supply on PCB in the tape reader.	
9	Tape reader is faulty.		Replace the tape reader.
10	Confirmation	Input tape code is EIA.	Proceed to 12 .
		Input tape code is ISO.	Proceed to 11 .
11	Fixed parameter setting is erroneous.	Collate the contents of parameters 000-004 with the parameter table accompanying the NC.	
12	Tape is loaded face downward.		
13	Tape is other than black. (In case using tape reader with reels)		Replace it by black one.
14	EOB punching is mistaken.	Check EOB code on paper tape.	

15	Tape reader adjustment is not good.	① See Item 3.5 to make sure that photo-amplifier LED (green) on PCB is lit. ② See Item 3.5 to adjust the photo-amplifier.	
16.	LEDs on master PCB are on.	See Item 3.3.4.	
17	Cable connection is erroneous	Check the cable for connection.	
18	Tape reader is faulty.		Replace the tape reader.
19	Master PC board is faulty.		Replace the PC board.

3.3.9 Automatic operation is impossible

Item	Cause	Checking	Countermeasures
1	Confirmation	Turn ON/OFF the START button in automatic (T, D or MEM) mode.	
		① No STL lamp lights.	Proceed to 2 .
		② STL lamp lights but no axis moves.	Proceed to 7 .
2	No mode signal has been input.	Check DGN 105.	
3	No start signal has been input.	Make sure that turning START button ON/OFF, makes bit 2 of DGN 101 1/0.	
4	Feed hold signal (*SP) has been input.	Make sure that bit 5 of DGN 102 is 1.	
5	Reset signal has been input.	Make sure that bits 6 and 7 of DGN 102 are 0, and that bit 4 of DGN 102 is 1.	
6	LEDs on master PCB are on.	See Item 3.3.4.	
7	① Override is set at 0%. ② Interlock is ON. ③ In-position check is in effect. ④ Dwell is in execution. ⑤ M, S or T function is in execution. ⑥ Waiting for spindle arrive signal. ⑦ Tape reader is operating	Check DGN 700, 701 and 712.	

3.3.10 No S4 digit analog output is produced

Item	Cause	Checking	Countermeasures
1	Confirmation	Issue G97S – M03 command in MDI ((press PAGE button to make sure on CURRENT BLOCK screen that this signal has been accepted). At that time, make sure that DGN 68, 69 causes R01~R12 to establish the following equation. $R12 \times 2^{11} + R12 \times 2^{10} + \dots + R01 \times 2^0$ $= 0.8 \times \frac{S}{S_{max}} \times \frac{S_{Ovr}}{100} \times 4095$ where S: specified number of revolutions (rpm) S _{max} : maximum number of revolutions of the then selected gear (parameters 120 ~ 123) S _{Ovr} : spindle override (%)	
		R01 ~ R12 are all 0.	Proceed to 2 .
		R01 ~ R12 differ from the above equation.	Proceed to 3 .
		R01 ~ R12 differ from the above equation, but no analog voltage is output.	Proceed to 9 .
2	Spindle stop signal (*SSTP) has been input.	Make sure according to the following that no *SSTP has been input. (1) When bit 4 of parameter 010 is 0, bit 7 of DGN 106 is 1. (2) When bit 4 of parameter 010 is 1, bit 7 of DGN 106 is 0.	
3	Parameter is set to output S code (BCD)	Make sure that bit 4 of parameter 005 is 0.	
4	Gear select signal GR1 ~ GR4 aren't input correctly.	Check DGN 106 GR1 is selected when GR1~GR4 are all zero.	
5	Spindle maximum feedrate setting is erroneous (parameter setting error).	Make sure that parameters 120 ~ 123 have been set correctly.	
6	S analog output gain setting is erroneous (parameter setting error).	Check if parameter 140 is 1000.	
7	Fixed parameter setting is erroneous.	Collate the contents of parameters 000-004 with the parameter table attached to the NC.	
8	LEDs on master PCB are lit.	See Item 3.3.4.	
9	Confirmation	Make sure by DGN 004, 005 that R01 ~ R12 are the same as by DGN 068, 069 (for the NC with Programmable Controller, however, may vary, according to its specifications).	

		Same condition, but no S analog voltage is output.	Proceed to 10.
		Vary.	Proceed to 14.
10	Cable connection is erroneous.	<ol style="list-style-type: none"> 1) For X, Z axes NC side output connector . . . C08 2) In case there is axis other than X, Z axes NC side output connector . . . C18 	
11	Load is abnormal	<ol style="list-style-type: none"> 1) For X, Z axes Remove the cable connection to NC-side connector C08 and check the voltage between C08 connector pin 7 (VCMS) and pin 19 (ECS). 2) In case there is axis other than X, Z axes. Remove the cable connection to NC-side connector C18 and check the voltage between C18 connector pin 7 (VCMS) and pin 19 (ECS). 	
12	LEDs on master PCB light.	See Item 3.3.4.	
13	PCB is faulty.	<ol style="list-style-type: none"> 1) For X, Z axes Master PCB A20B-0008-0410 is faulty. 2) Other axis than X, Z axes PCB A20B-0008-0470 is faulty. PCB A20B-0008-0471 is faulty. PCB A20B-0007-0090 is faulty. or the cable in the NC, connecting C18 and CH1, is faulty. 	
14	Check specifications of Programmable Controller, if attached.	Check if signals from the machine tool clamp the S analog output on the Programmable Controller.	
15	LEDs on master PCB are lit.	See Item 3.3.4.	
16	Master PCB is faulty.		

3.3.11 S4-digits analog output voltage linearity is not good

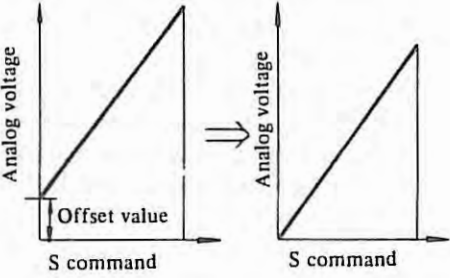
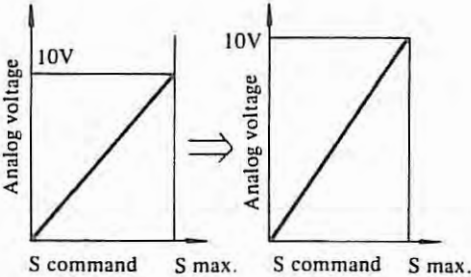
Item	Cause	Checking	Countermeasures
1	Parameter setting is erroneous.	<p>1 Command S0 so that output voltage may become 0V. Then make sure that S analog voltage is 0V (offset adjustment). When not, set parameter 119 so that 0V may be output.</p>  <p>2 Command Smax so that output voltage may become 10V. Then make sure that S analog voltage is 10V (gain adjustment). When not, set parameter 140 according to the following equation, so that 10V may be output.</p> $\frac{10.0}{\text{Measured voltage (V)}} \times 1000 = \text{Setting value}$ 	
2	Load is abnormal	See 11 of Item 3.3.10.	
3	PCB is faulty	See 13 of Item 3.3.10.	

3.3.12 FACIT 4070 does not operate normally

Item	Cause	Checking	Countermeasures
1	Confirmation	Let FACIT 4070 punch to check the following.	
		Does not punch. No EDIT is displayed below on CRT screen.	Proceed to 2 .
		Does not punch. EDIT is displayed below on CRT screen.	Proceed to 7 .
		Punch code differs.	Proceed to 13 .
2	Reset signal has been input.	Make sure that bits 6 and 7 of DGN 102 are 0, and that bit 4 of DGN 102 is 1.	
3	No mode signal has been input.	Check DGN 105 to make sure that only one of EDT and MEM modes is 1.	
4	Fixed parameter setting is erroneous.	Collate the contents of parameters 000 ~ 004 with the parameter table attached to the NC.	
5	LEDs on master PCB light.	See Item 3.3.4.	
6	Punch buttons are faulty.		Replace MDI & CRT unit.
7	Setting is erroneous.	Makes sure that NO 341 is 0 in setting (or that parameter 341 is 0).	
8	FACIT 4070 is operated wrongly (or is faulty).	Make sure that: ① Ready lamp is lit. ② Error lamp is not lit. on FACIT 4070	
9	Cable connection is erroneous.	Check cable connection and wiring.	
10	LEDs on master PCB are lit.	See Item 3.3.4.	
11	PCB A20B-0008-0430 is faulty.		Replace the PCB.
12	Master PCB is faulty.		Replace the PCB.
13	Setting is erroneous.	ISO/EIA code is considered to have been set irrelevantly. Check punched codes.	
		ISO codes are output, when EIA ones are to be.	Change to EIA by setting.
		EIA codes are output, when ISO ones are to be.	Change to ISO by setting. Check fixed parameters 000-004.
		Punched codes are nonsense.	Proceed to 9.

3.3.13 ASR 33/43 does not operate normally

Item	Cause	Checking	Countermeasures
1	Confirmation	Let ASR 33/43 punch to check the following	
		Does not punch. No EDIT is displayed below on CRT screen.	Proceed to 2 .
		Does not punch. EDIT is displayed below on CRT screen.	Proceed to 7 .
		Punched code differs.	Proceed to 14 .
2	Reset signal has been input.	Make sure that bits 6 and 7 of DGN 102 are 0, and that bit 4 of DGN 102 is 1.	
3	No mode signal has been input.	Check DGN 105 to make sure that only one of EDT and MEM modes is 1.	
4	Fixed parameter setting is erroneous.	Collate the contents of parameters 000-004 with the parameter table attached to the NC.	
5	LEDs on master PCB light.	See Item 3.3.4.	
6	Punch buttons are faulty.		Replace MDI & CRT unit.
7	Setting is erroneous.	Makes sure that NO 341 is 1 in setting (or that parameter 341 is 1).	
8	Baud rate setting is erroneous.	Check parameter 310 for setting. ① Baud rate: 110 for ASR33 I/O setting for ASR 43 ② Stop bit: two bits ③ Control code: not used.	
9	ASR 33/43 is operated wrongly (or is faulty).	Check if: ① AC is supplied. ② The unit is set in LINE.	
10	Cable connection is erroneous.	Check cable connection and wiring.	
11	LEDs on master PCB are lit.	See Item 3.3.4.	
12	PCB A20B-0008-0430 is faulty.		Replace the PCB.
13	Master PCB is faulty.		Replace the PCB.
14	Setting is erroneous.	ISO/EIA code is considered to have been set irrelevantly. Check punched codes.	
		ISO codes are output, when EIA ones are to be.	Change to EIA by setting.
		EIA codes are output, when ISO ones are to be.	Change to ISO by setting. Check fixed parameters 000-004.
		Punched codes are nonsense.	Proceed to 8 .

3.3.14 RS-232C interface does not operate normally

Item	Cause	Checking	Countermeasures
1	Confirmation	Neither punching nor reading is possible. As a result, no EDIT is displayed below on CRT screen.	Proceed to 2
		Neither punching nor reading is possible. But EDIT is displayed.	Proceed to 6
		Punching is possible, but reading is impossible.	Proceed to 13
		Reading is possible, but punching is impossible.	Proceed to 13
		Alarm occurs. (085 ~ 087)	Proceed to Item 3.2
2	Reset signal has been input.	Make sure that bits 6 and 7 of DGN 102 are 0, and that bit 4 of DGN 102 is 1.	
3	No mode signal has been input.	Check DGN 105 to make sure that only one of EDT and MEM modes is 1.	
4	Fixed parameter setting is erroneous.	Collate the contents of parameters 000-004 with the parameter table attached to the NC.	
5	LEDs on master PCB light.	See Item 3.3.4.	
6	Setting is erroneous.	Makes sure that NO 340, 341 is 2, 3 or 4 in setting (or that parameter 340, 341).	
7	Baud rate setting is erroneous.	When this parameter is unusual, alarm 85/86 occurs. When NO 340, 341 is 2 in setting, see parameter 311. When NO 340, 341 is 3 in setting, see parameter 312. When NO 340, 341 is 4 in setting, see parameter 313. ① Baud rate ② Stop bit ③ Control bit	
8	I/O device is operated wrongly (or is faulty).	See the I/O device operation guide for correct operation.	
9	Cable connection is erroneous.	Check cable connection and wiring (signal connection is based on the specifications determined between machine tool builder and I/O device maker).	
10	LEDs on master PCB are lit.	See Item 3.3.4.	
11	PCB A20B-0008-0430 is faulty.		Replace the PCB.
12	Master PCB is faulty.		Replace the PCB.
13	Setting is erroneous.	ISO/EIA codes are considered to have been set irrelevantly. 1 Check setting. 2 Check fixed parameters 000-004. 3 Proceed to 9 .	

3.3.15 Stop position does not coincide with reference point in reference point return

1-grid deviation

Item	Cause of trouble	Check procedure	Countermeasure
①	The deceleration dog position is not correct.	Move the machine tool from the reference point for the distance to the deceleration dog and check the deceleration signal with the diagnostic function. Read the distance between the reference point and the deceleration dog on the NC position display.	The distance between the deceleration dog and the reference point should be equivalent to one-half of a motor revolution.
②	The deceleration dog length is too short.	Use the procedure given in item ① above to read the length of the deceleration dog.	Replace the dog.

Random deviation

Item	Cause of trouble	Check procedure	Countermeasure
①	Noise	Check whether the shielding is grounded or not. Check that spark suppressors are connected to the solenoid coil, etc. Check whether the pulse coder cable and the power cable are in proximity.	Ground the shielding wire. Connect the spark killer. Separate the pulse code and power cables.
②	Source voltage to the pulse coder is too low.	When the voltage at power checking terminals on the master PCB is $5.0V \pm 0.05V$, the source voltage should be 4.75V or more. (Remove the pulse coder cover and measure the source voltage at the ⊕ and ⊖ terminals on the pulse coder board.)	Cable loss must be 0.2V or less. The voltage at +5V terminal on the master PCB should be within the range of 4.95 to 5.10 V.
③	Coupling between the servo motor and the machine tool is loose.	Mark the motor shaft and check the correspondence between the shaft and machine tool position.	Tighten the coupling.
④	Defective pulse coder.	Replace the pulse coder.	Replacement.
⑤	Defective master PC board.	Replace the master board.	Replacement.

Minute deviation

Item	Cause of trouble	Check procedure	Countermeasure
①	Broken cable or defective connector.	Check that the cable connector is tight. Check the solder connections and bends in the cable.	Repair the connection.
②	Variation in offset voltage. Defective master PCB or velocity control unit.	Release the drift compensation function with the parameter and check the position deviation using the diagnostic function. The offset value variation corresponds to the variation of the position deviation value. Replace the master PC board or the velocity control unit board to determine the source of the problem.	Replace the faulty board.

Checking method of reference point return operation and deceleration dog position.

- (1) **Set the parameter according to blow table**
Set '0' to parameter 082 ~ 085.

Parameter number	Contents
010	When optional stored stroke limit is equipped with, manual rapid traverse is effective or not without performing the reference point return.
011	Deceleration signal (*DECX, *DECY, *DECZ, *DEC4) is "1" in reference point return shows deceleration or "0".
012	Reference point return method and direction.
014 ? 017	Capacity of reference counter for each axis.
020	Reference point return function is provided or not.
082 ? 085	Setting of grid shift amount of each axis.
114	Low feed rate for reference point return.
159 ? 162	Distance from second reference point to first reference point of each axis.
367 ? 370	Distance from third reference point to first reference point of each axis.
371 ? 374	Distance from fourth reference point to first reference point of each axis.

- (2) Perform the reference point return and confirm the operation is correct.
In case reference point adjustment is needed.
- i) grid method Adjusted by grid shift amount (parameter 082 ~ 085)
Then if reference point shifts a portion of 1 revolution of detector (pulse coder, resolver). Deceleration dog must be shifted.
 - ii) magneswitch method Adjusted by position of proximity switch.
- (3) Confirm the deceleration dog position. (only grid method)
- i) Perform reference point return.
 - ii) Write down data of position display at reference point.
 - iii) Check deceleration dog signal (*DECX, *DECY, *DECZ, *DEC4) in DGN 032 ~ 35 and return the machine to DEC signal on position from reference point.
 - iv) Calculation the distance from reference point to DEC signal on position by (ii) (iii) procedure. And make that distance a half of movement distance of detector 1-revolution by adjustment of Deceleration dog.

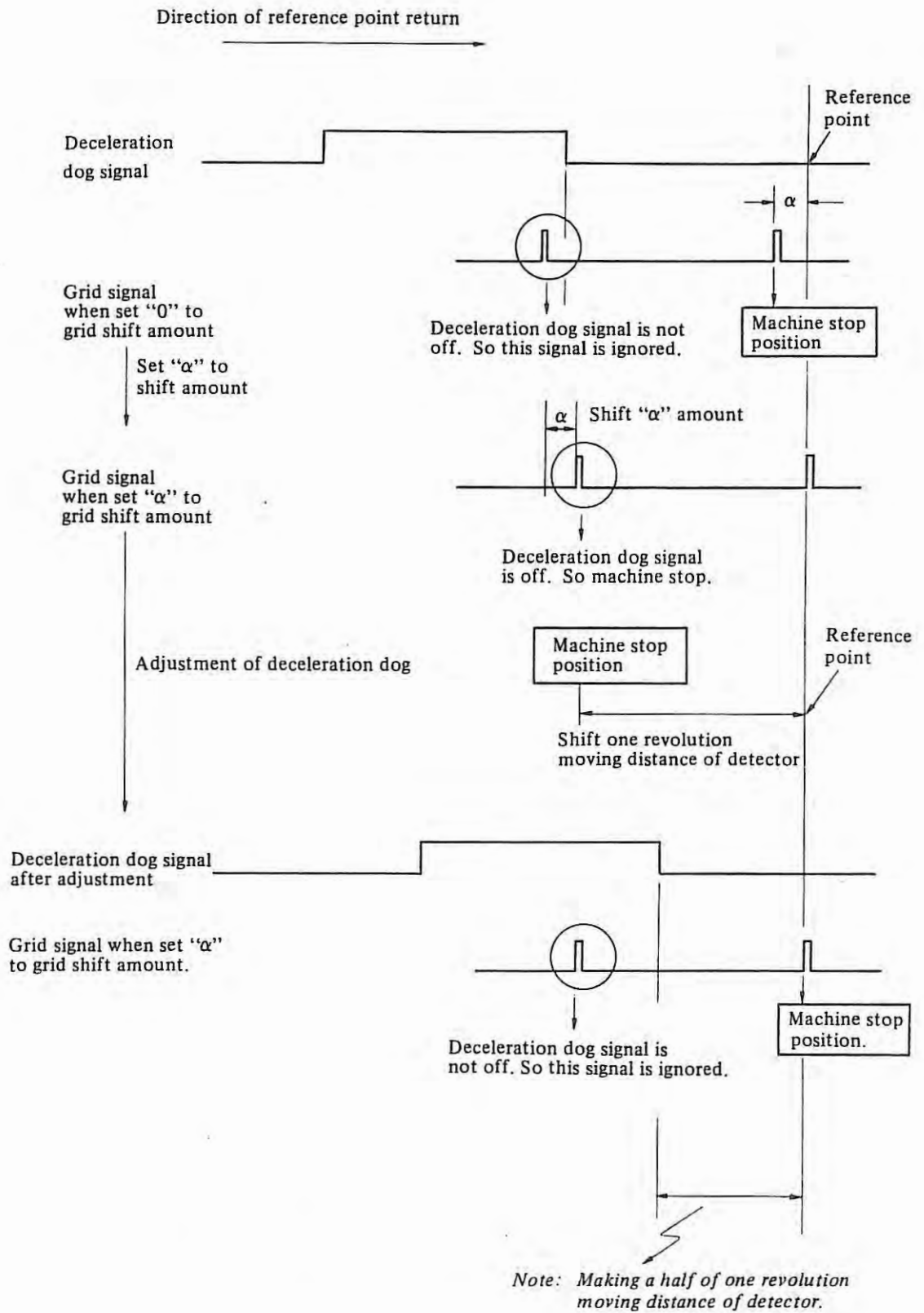

3.4 Power supply voltage checking

3.4.1 Input power supply voltage checking

There are two kinds of input units.

- (1) For control unit Fig. 3.4.1 (a)
- (2) For control unit and servo Fig. 3.4.1 (b)

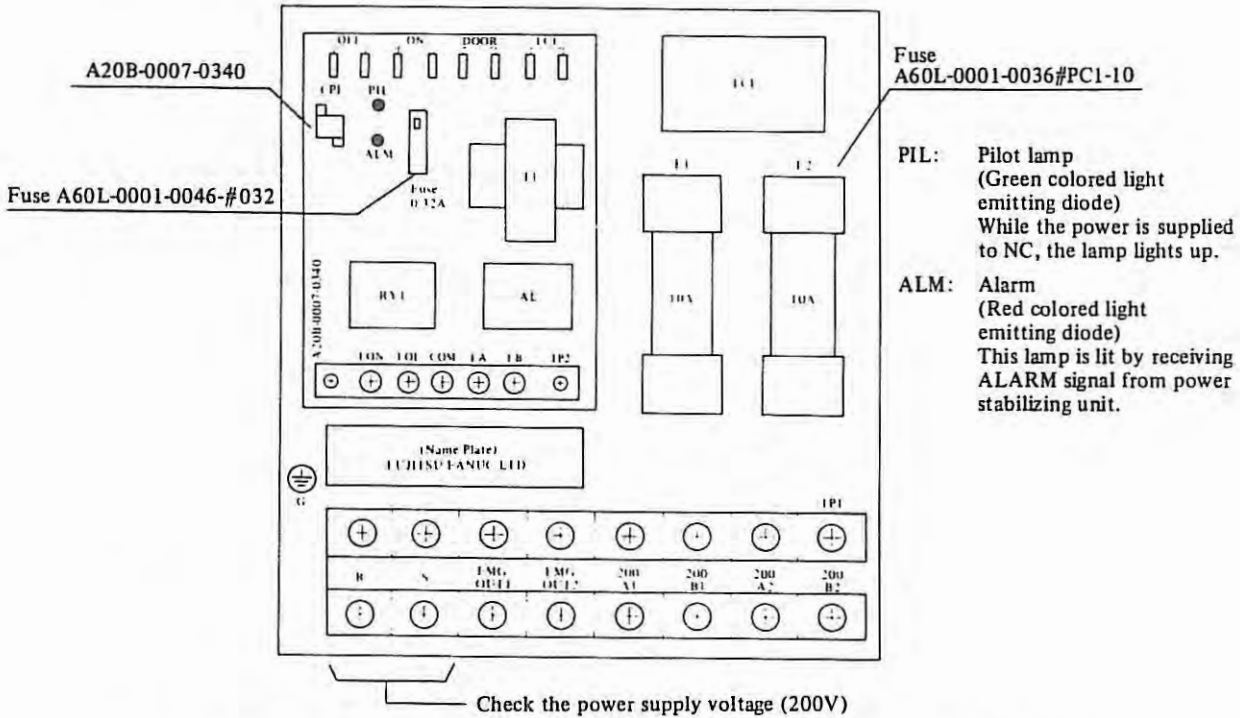

Fig. 3.4.1 (a) Input Unit for Control Unit (For Built-in type 1 and Unbundled type cabinet)

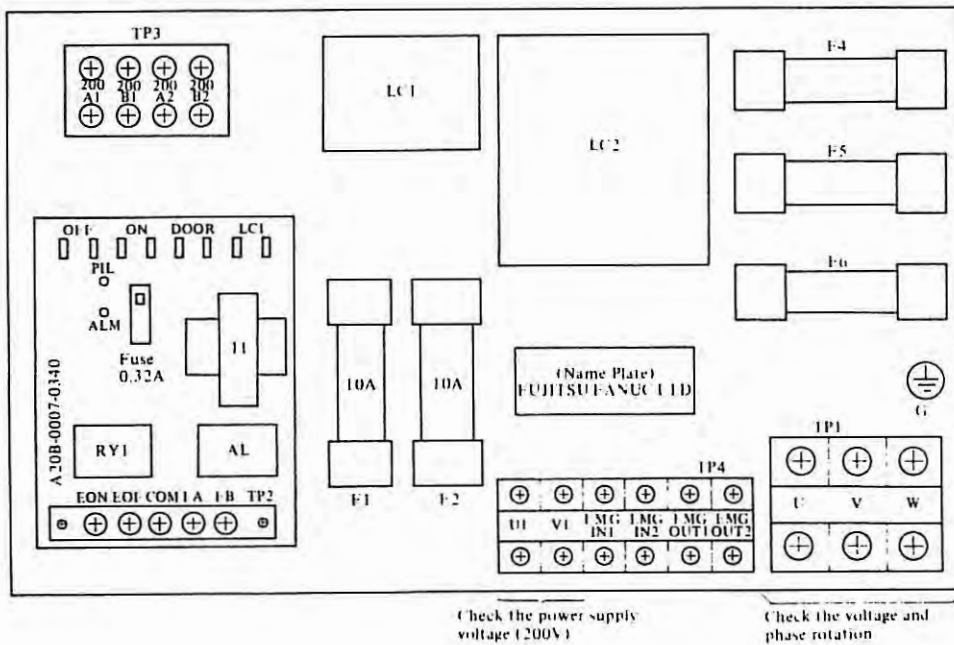

Fig. 3.4.1 (b) Input Unit for Control Unit and Servo (For Free-standing type and Built-in 2 type cabinet)

- F1, F2 Input fuse for control unit 10A
 F3 Fuse for power supply ON/OFF control circuit 0.32A
 F4 ~ 6 Input fuse for servo transformer

The capacity differs from servo transformer in the Table 3.4.

Table 3.4.1 (a) Table of input Fuse for Servo Transformer (For H series)

Servo Power Transformer Name		Power Transformer specification	Nominal capacity	Fuse
AC200/220V	Power transformer A	A80L-0001-0079	5kVA	30A
	Power transformer B	A80L-0001-0080	5kVA	30A
	Power transformer C	A80L-0001-0081	2.5kVA	20A
	Power transformer D	A80L-0001-0082	2.5kVA	20A
	Power transformer E	A80L-0001-0099	1.2kVA	15A
	Power transformer F	A80L-0001-0110	1.4kVA	15A
AC200~550V	Power transformer AE	A80L-0001-0083	5kVA	30A
	Power transformer BE	A80L-0001-0084	5kVA	30A
	Power transformer CE	A80L-0001-0088	2.5kVA	20A
	Power transformer DE	A80L-0001-0089	2.5kVA	20A
	Power transformer EE	A80L-0001-0100	1.2kVA	15A
	Power transformer FE	A80L-0001-0111	1.4kVA	15A
AC200/220V	Power transformer Q	A80L-0001-0057	10kVA	40A
AC200~480V	Power transformer QE1	A80L-0001-0059	10kVA	40A
AC200/500V	Power transformer QE2	A80L-0001-0061	10kVA	40A

Table 3.4.1 (b) Table of input fuse for servo transformer (for M series)

Power voltage	Fuse type		Utsunomiya Electric Co., Ltd. PC type	Fuji Electric Co., Ltd. FCF type
	Transformer capacity (KVA)			
200V 220V	1.5KVA		15A	20A
	2.5		20	30
	5		30	30
	10		40	40
	15		50	50
380V ? 440V	1.5		10	10
	2.5		10	15
	5		15	15
	10		25	30
	15		30	30

Power voltage	Fuse type		Utsunomiya Electric Co., Ltd. JG type	Fuji Electric Co., Ltd. Plug type
	Transformer capacity (KVA)			
480V ?	1.5KVA		10A	10A
	2.5		10	15
	5		15	20
550V	10		20	30
	15		25	30

3.4.2 DC Voltage Checking

DC voltages supplied from the power unit must be measured at power checking terminals on the master PCB. Confirm that DC voltages are within the allowable range. Among these voltages, +5V can be adjusted with a variable resistor +5ADJ which is provided on the power stabilizer PCB.

(1) Rated output voltage

Terminal name	Rated voltage	Allowable fluctuation	Use
+5	+5V	±5%	Logical circuit Reed relay
+24	+24V	±10%	Taper reader, I/O signals Bubble memory, CRT
+15	+15V	±5%	Position control circuit
-15	-15V	±5%	Position control circuit Bubble memory
0	0V	—	—

Check point on master PCB

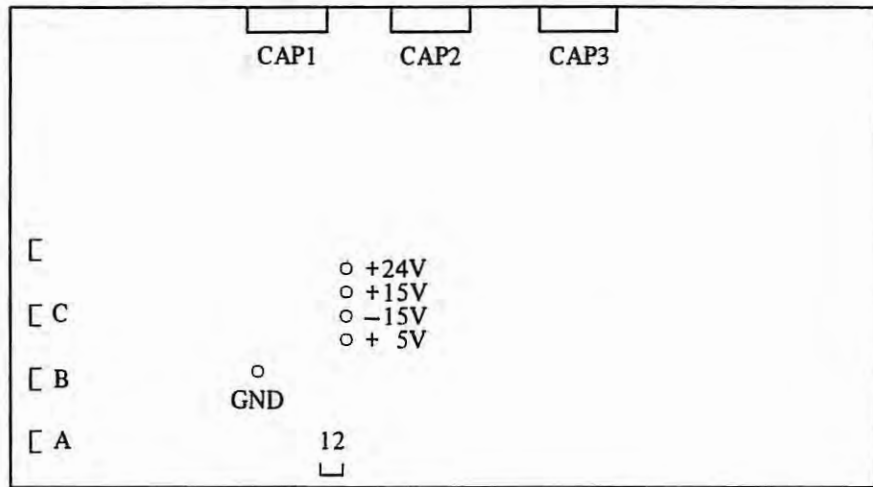

(2) Adjusting points on the power stabilizer PCB (A20B-0007-0330)

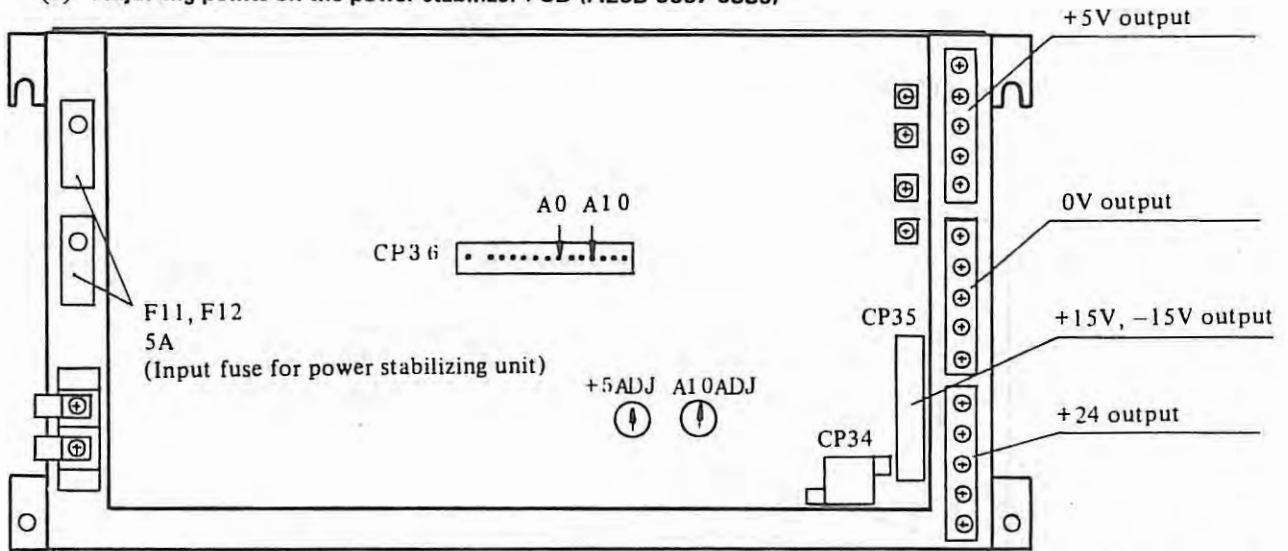

Although the standard voltage (+10V) does not normally need to be adjusted, a power supply alarm will generate when it is not within the allowable range. Adjust to 10.00V, measure the voltage between terminals A0 and A10 on the CP36. (Use a digital voltmeter.)

(3) Positions of the master PCB and the power stabilizer PCB.

(a) Free standing type cabinet

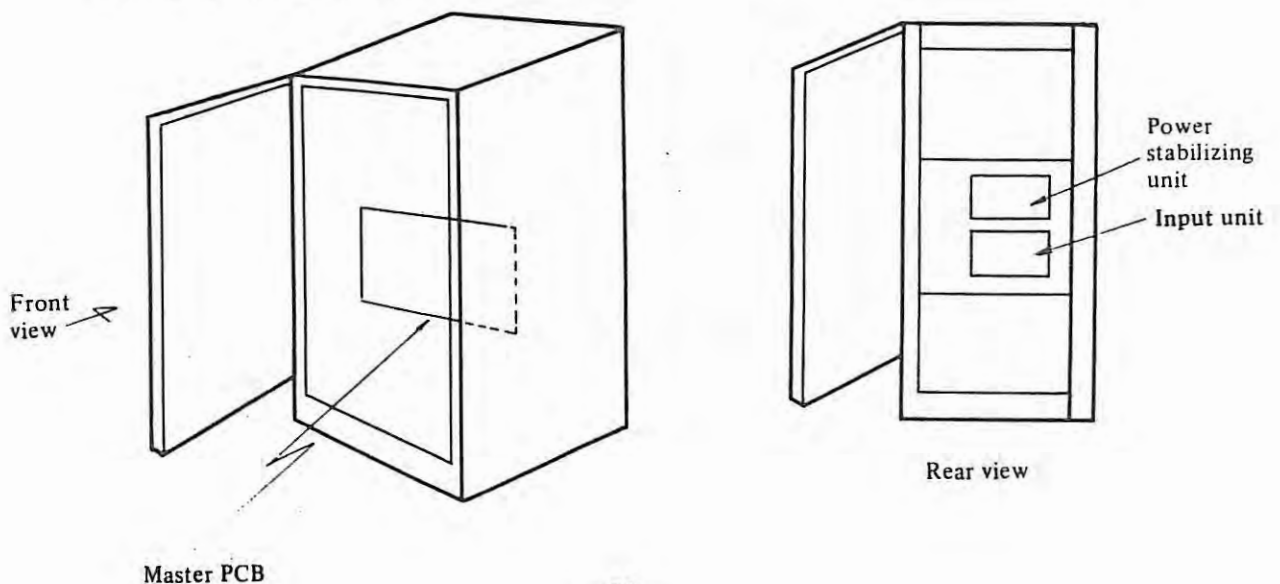

(b) Built-in type 1 cabinet

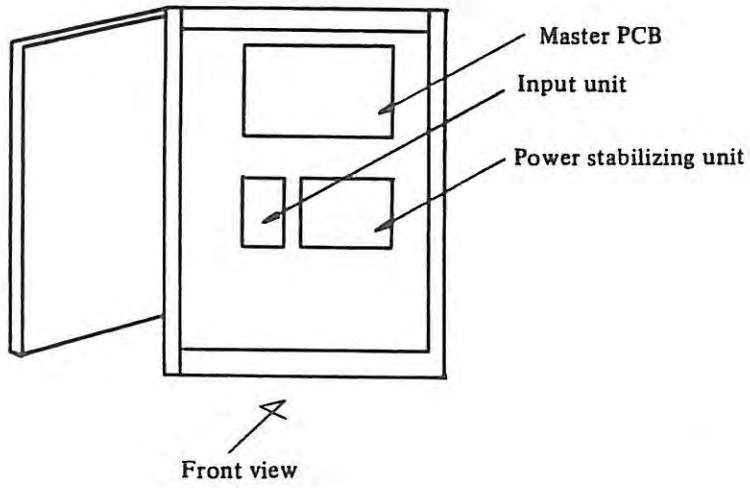

(c) Built-in type 2 cabinet

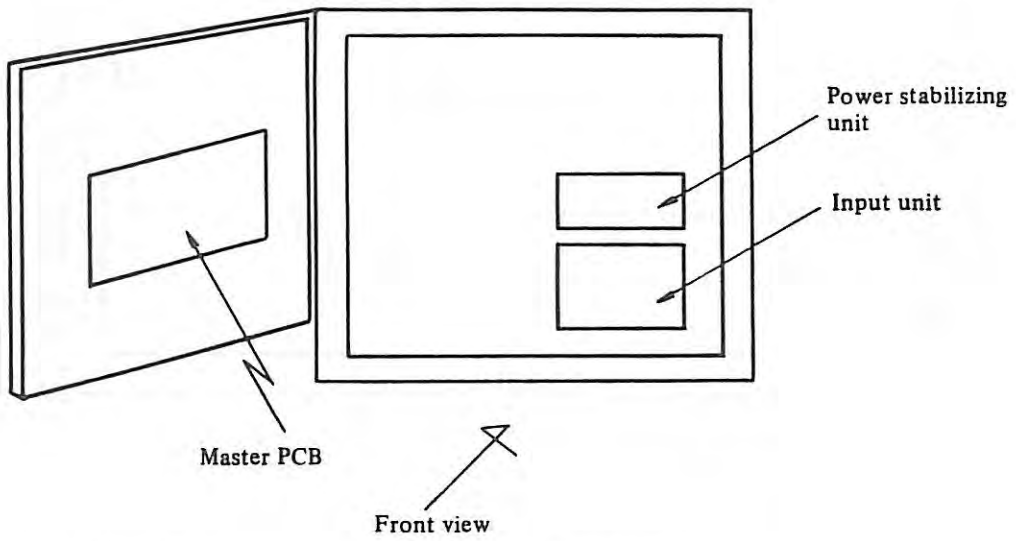

(d) Unbundled type cabinet

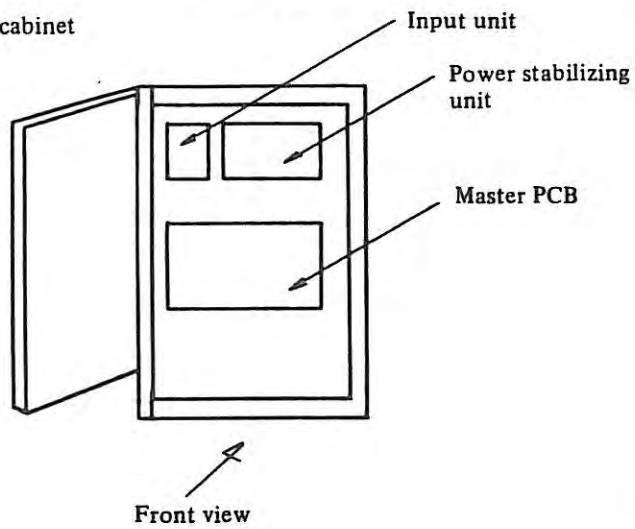

3.4.3 Servo power supply voltage on velocity control unit checking

(1) Check the each power supply output. (Check terminals on the firing circuit PCB.)

CH15	+24V (+23 ~ +27V)
CH16	+15V (+14.55 ~ +15.45V)
CH17	-15V (-14.55 ~ -15.45V)

(2) Check AC 100V power supply (Number 3 and 4 on T1 screw terminal)

If the emergency stop button is pushed, release this button.

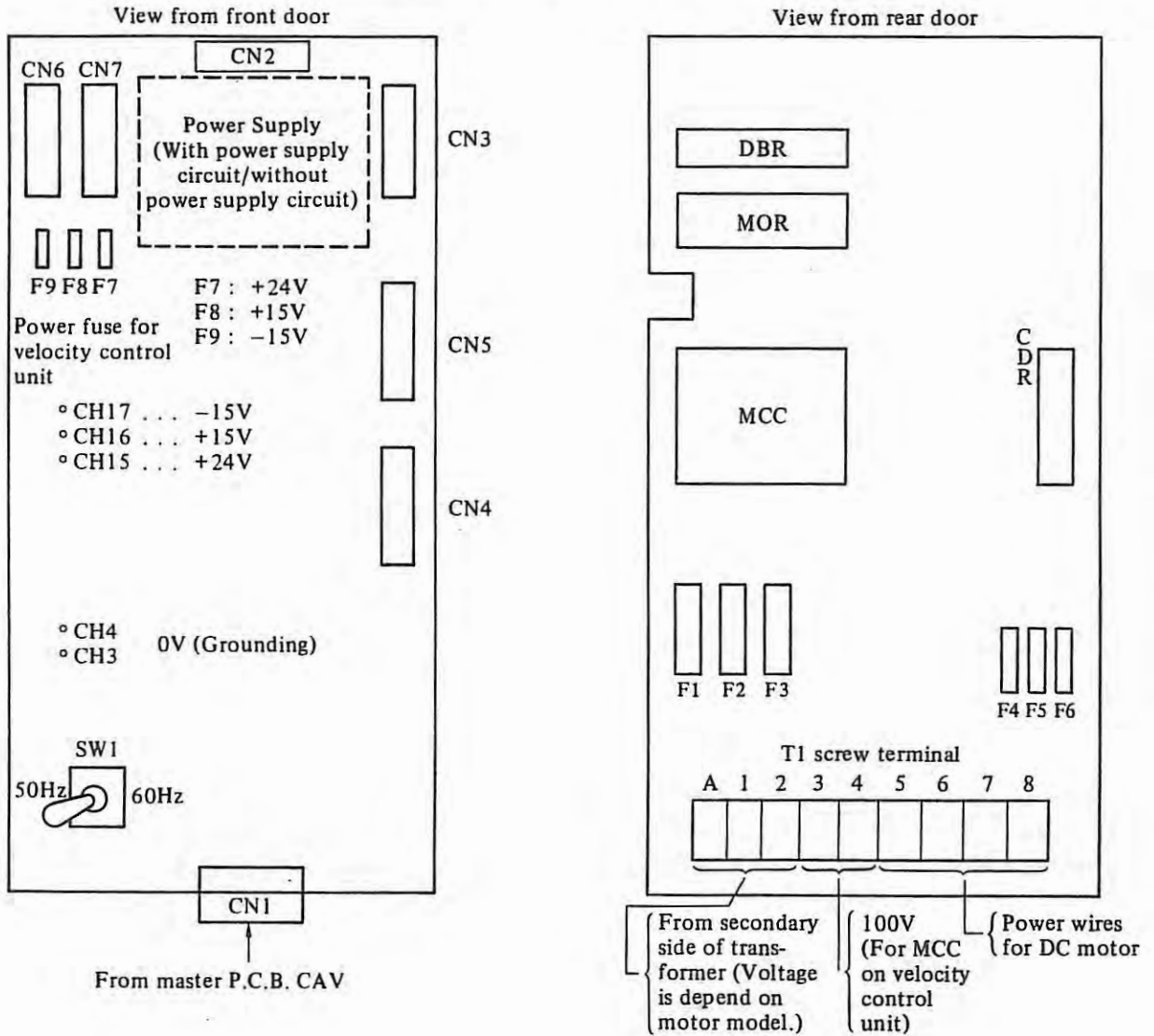

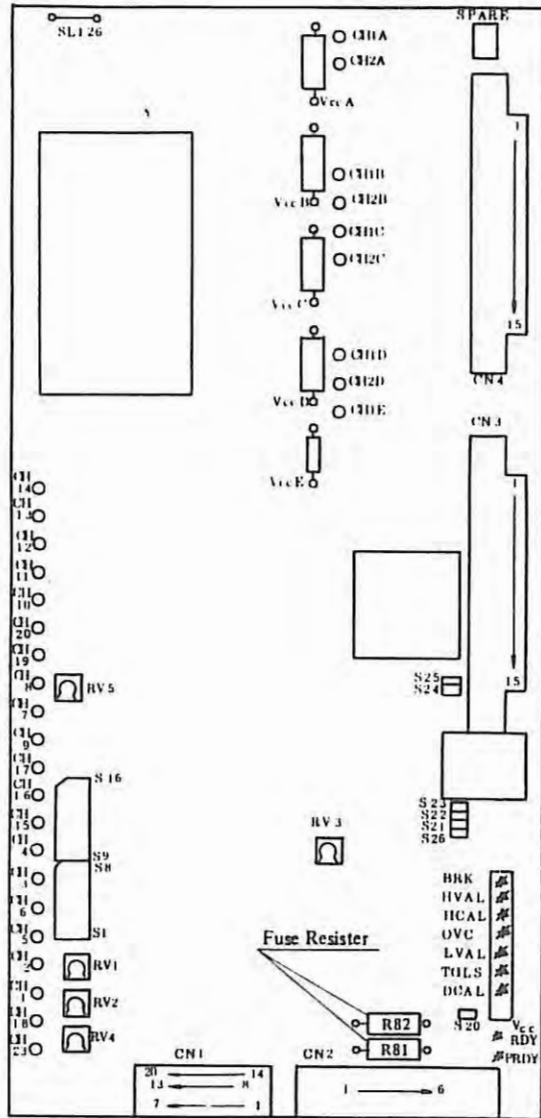

Velocity Control Unit PCB (For M series)

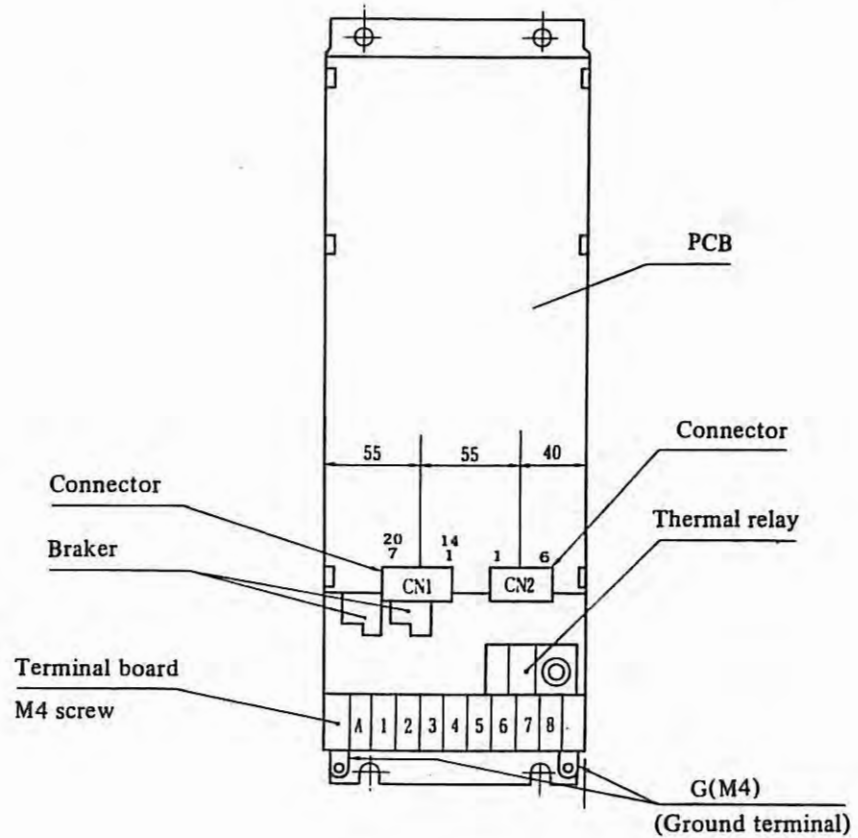

Velocity Control Unit (For M series)

3.5 Tape reader photo-amplifier adjustment

(1) With paper tape, make an about 40cm test tape as illustrated below that alternates punching and non-punching and connect both ends to form an endless loop of tape. (See Note 2, Note 3.)

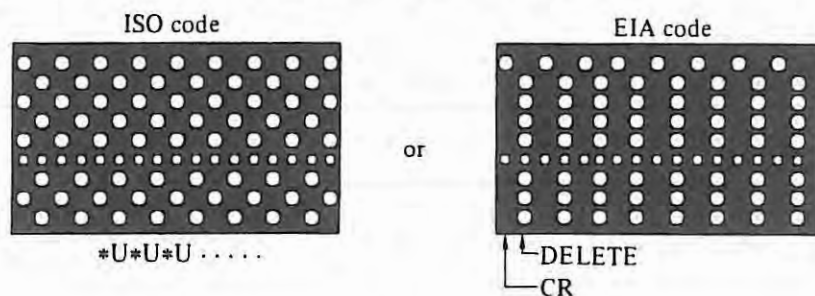

(2) Mount the test tape in the tape reader and turn the switch MANUAL to read the tape.

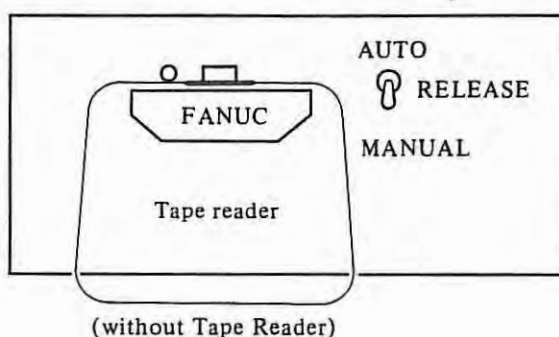

- (3) With an oscilloscope, measure the waveform between check terminals CHPS and CHG (ground) on the photo-amplifier. Adjust it with RV1 so that the ON/OFF timing ratio is 6:4.
- (4) Measure the waveforms at the check terminals CH1 through CH8 on the photo-amplifier using oscilloscope, and find the channel where the ON width is the shortest. (Use the terminal CHG for grounding.)
- (5) Measure the waveform where the ON width is the shortest among CH1 through CH8 and compare it with the waveform of CHPS. Adjust with RV2 so that the timing indicated in the diagram below is obtained.
- (6) Confirm that all the waveforms CH1 through CH8 satisfy the timing in the diagram below.

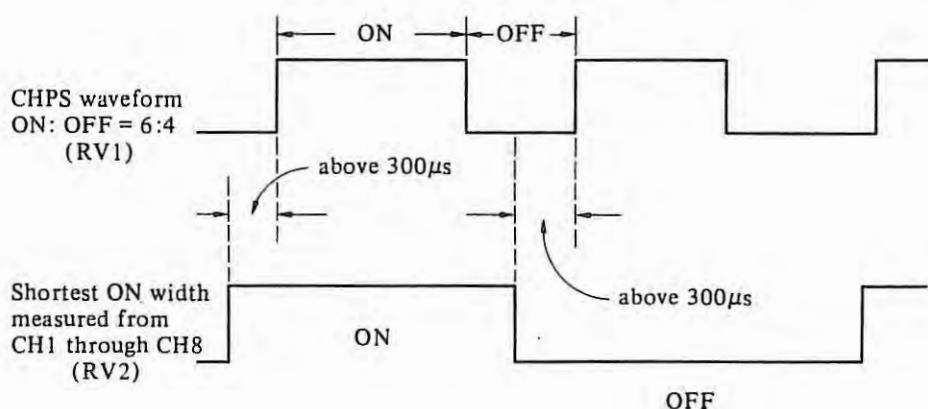

Note 1) Check terminals and variable resistor for adjustment are as follows.

	A860-0055-T062	A13B-0070-B001
Check terminal	CHPS	S
Grounding terminal	CHG	OV
Check terminal	CH1 ~ 8	1 ~ 8
Variable resistor for sprocket signal adjustment	RV1	SP
Variable resistor for data punching signal adjustment	RV2	Right variable resistor of SP (Variable resistor for data punching signal adjustment)

Note 2) When operating output waveform adjustment of the photo amplifier of A13B-0070-B001, use a paper tape of the color of blue, white, pink, yellow, orange, etc., other than black, gray, to perform the adjustment. A use of the tape, colored blue, white, pink, etc., if applied to the tape reader with the adjustment processed by using a black and gray colored tape, may sometimes cause an error of read. And for the case only with a black colored tape normally use, a black tape may be used for adjustment.

Note 3) In tape reader with reels, only black tape can be used. Please use the black tape for adjustment.

For tape reader without reel (A13B-0070-B001)

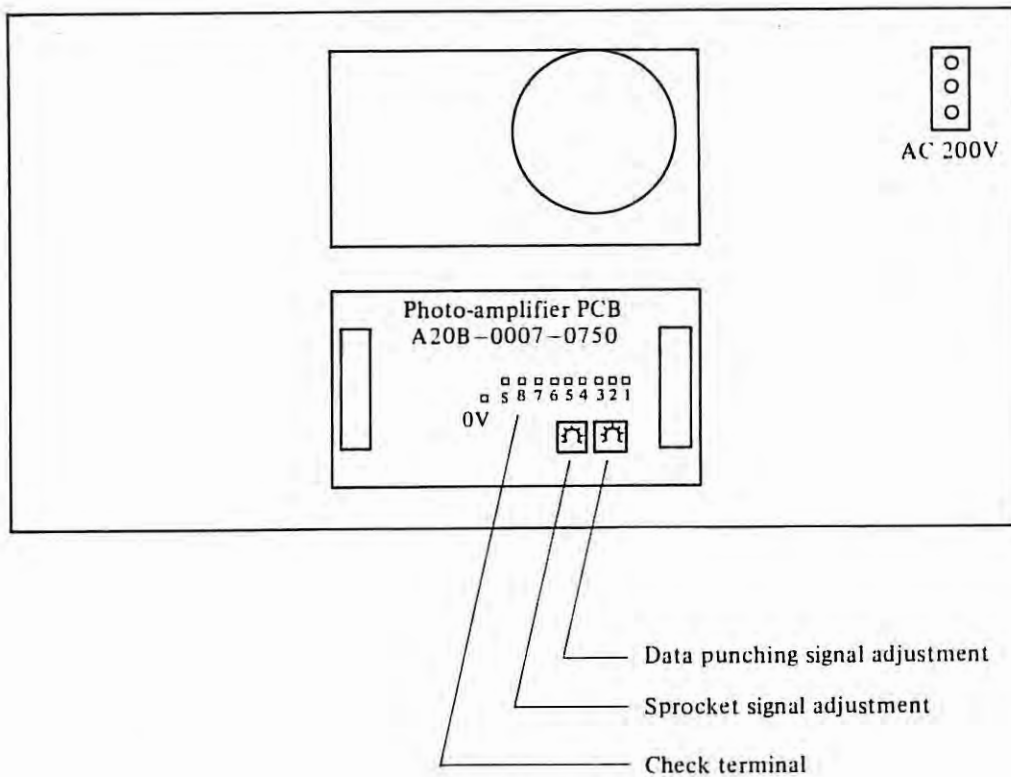

For tape reader with reels

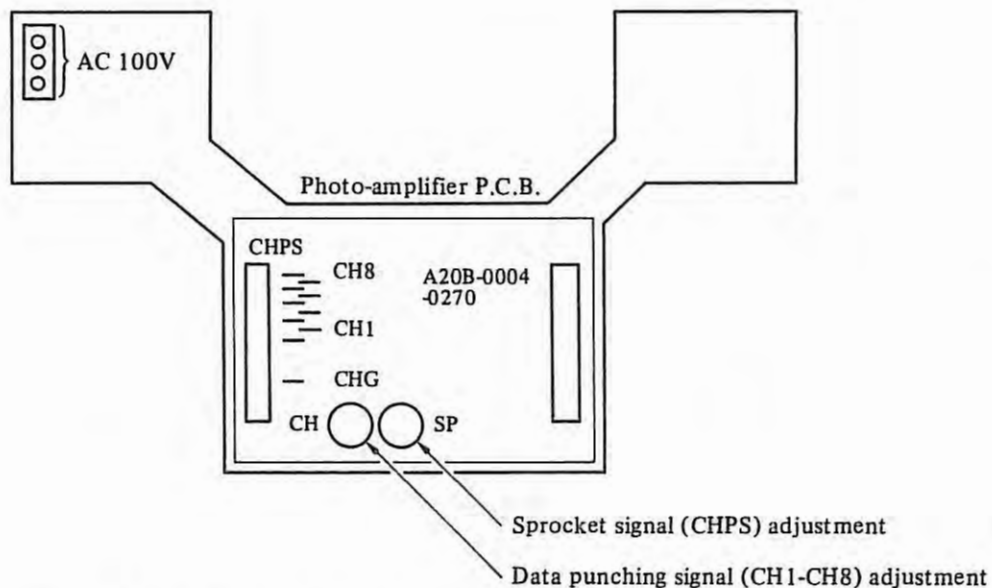

- Note 4) Because a light sensing part and a light emitting part of the tape reader are combined to be assumed as one part, only either one of them cannot be replaced.
- Note 5) Use paper tape that conforms to the following standard:
Paper tape for data exchange JIS C6243-1970
Position and size of paper tape punch for data exchange JIS C6246-1971
- Note 6) A read error will occur if another tape is used after the tape reader was adjusted with a black tape.

3.6 Connection diagram inside the NC

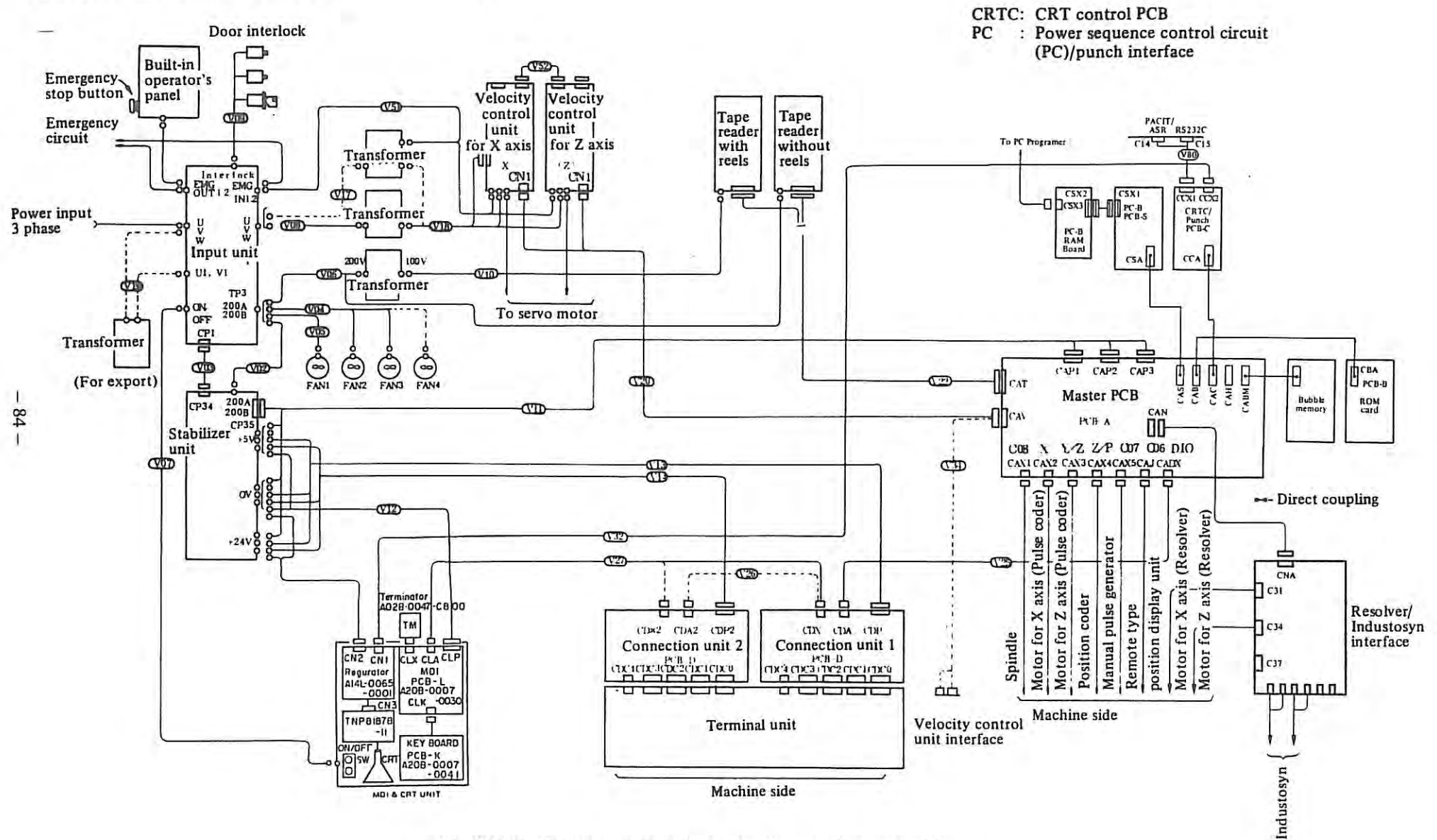

Fig. 3.6 (a) Total connection diagram for free standing type cabinet

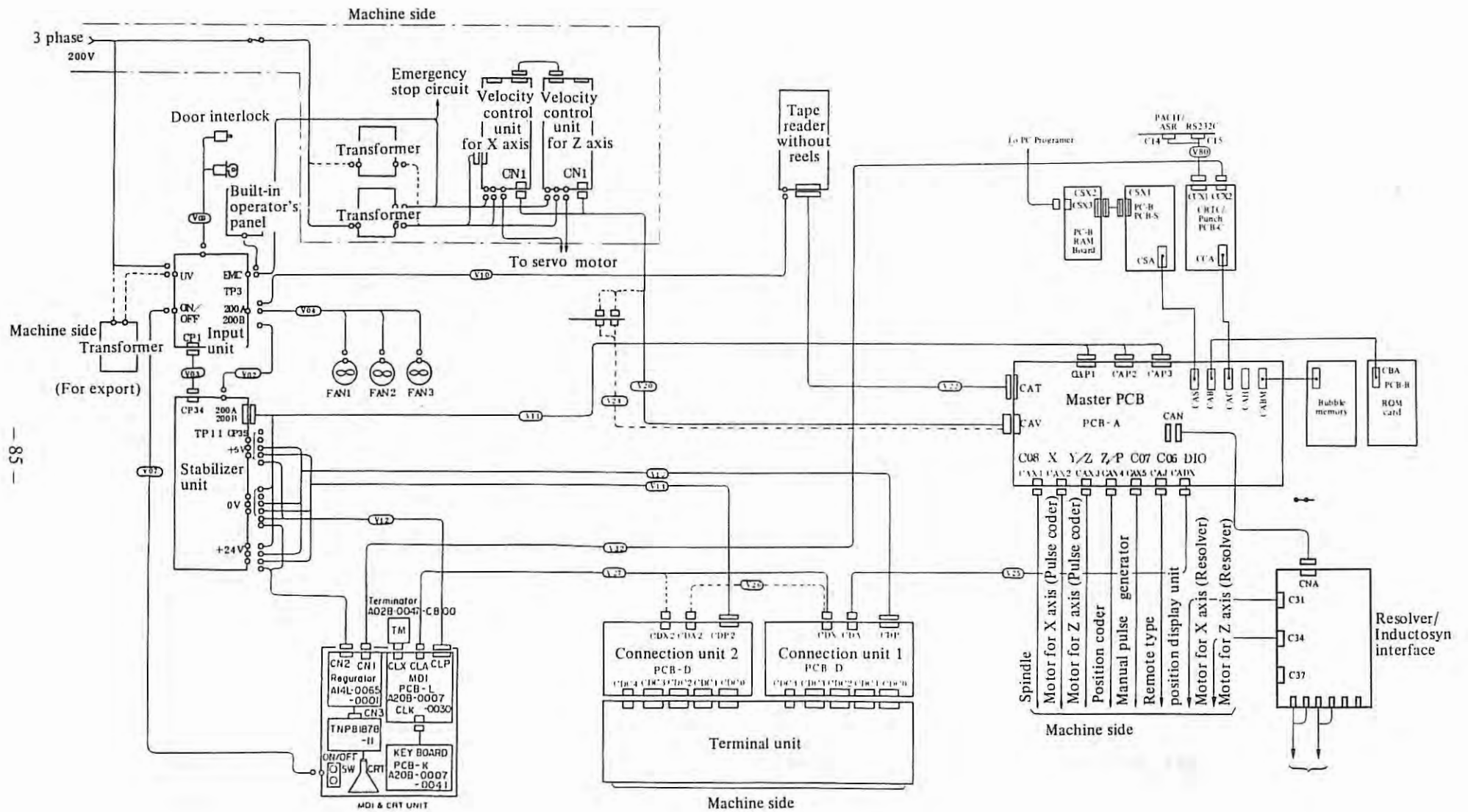

Fig. 3.6 (b) Total connection diagram for built-in type 1 cabinet

CAX3

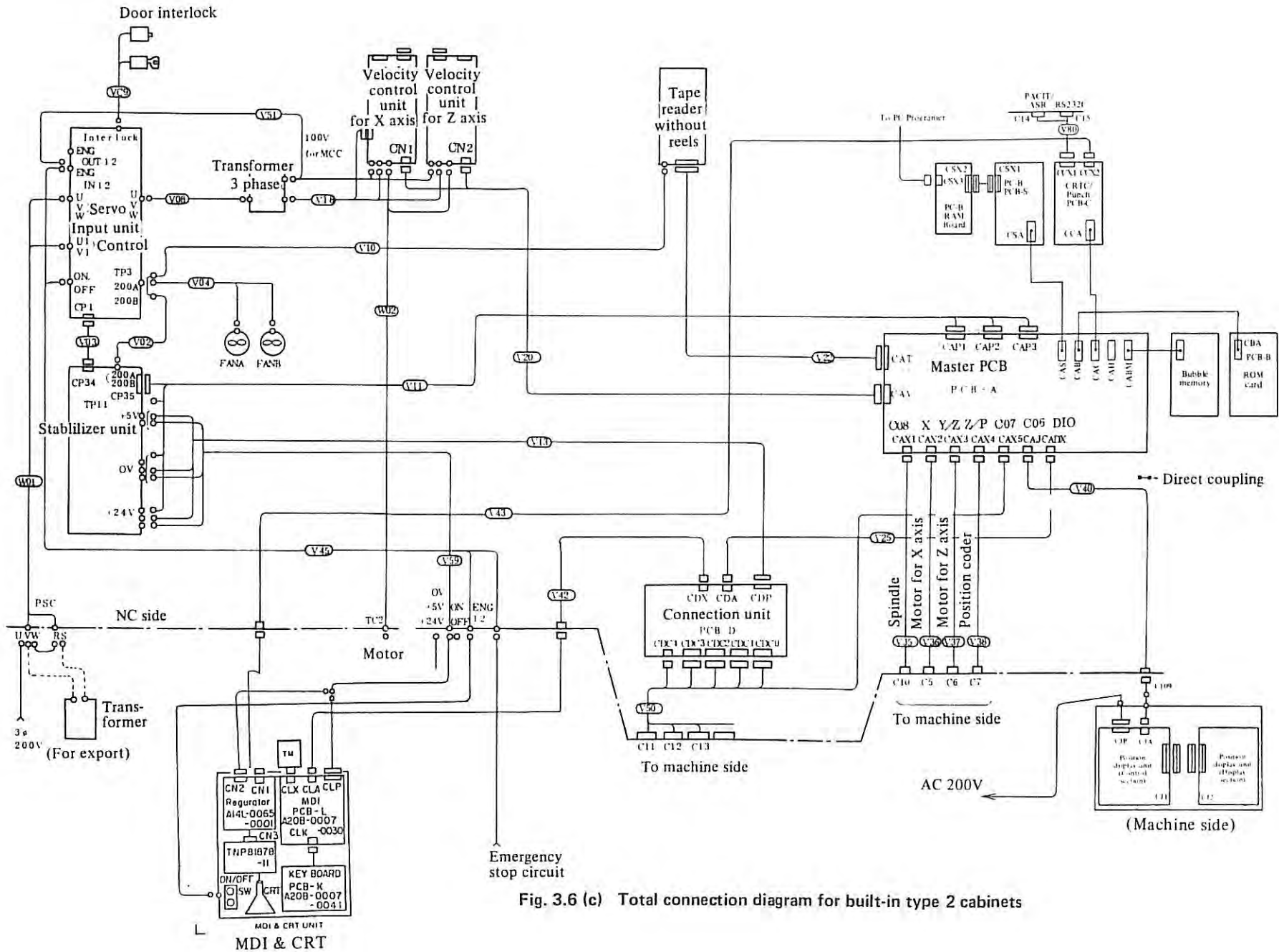

Fig. 3.6 (c) Total connection diagram for built-in type 2 cabinets

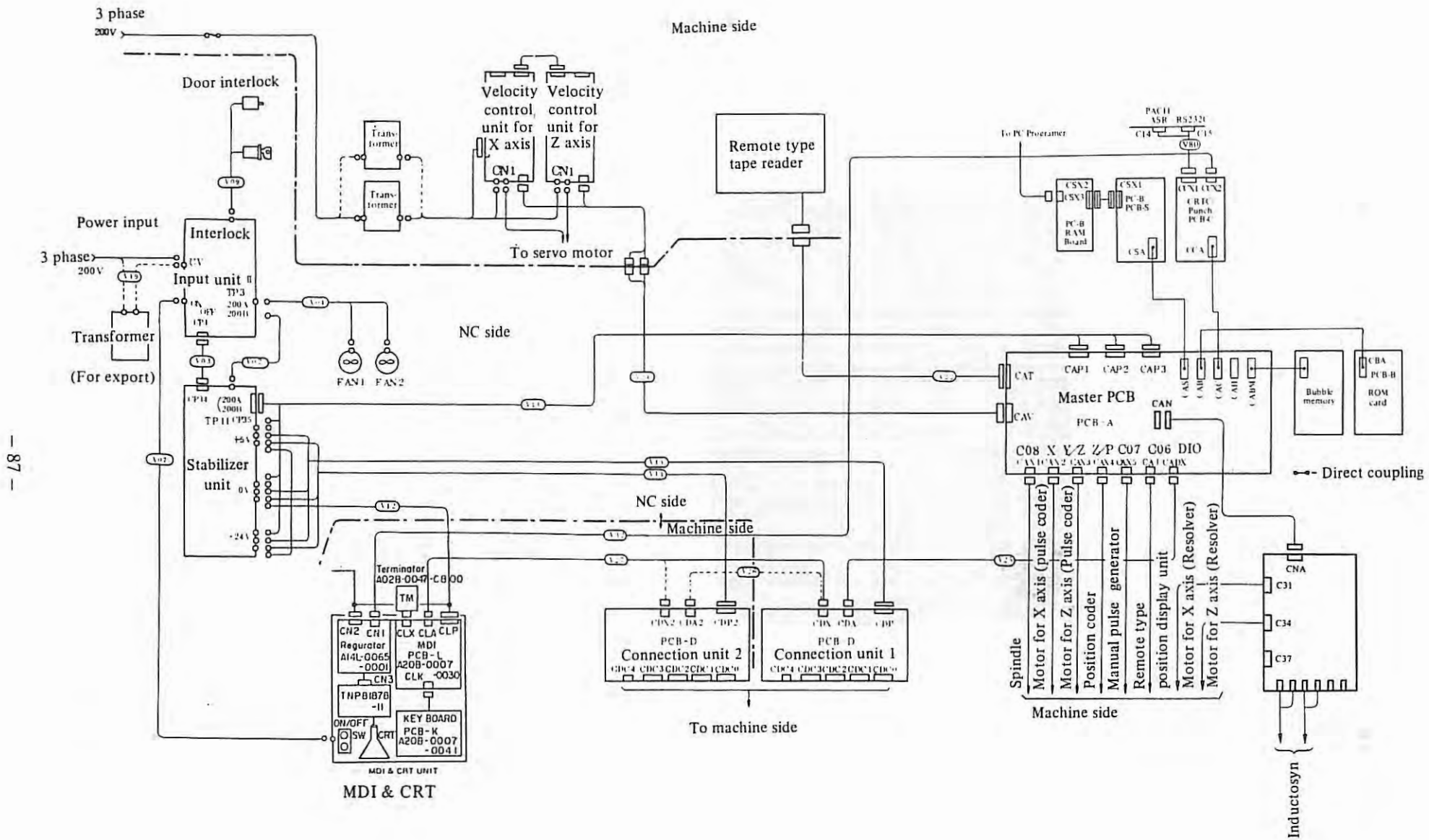

Fig. 3.6 (d) Total connection diagram for unbundled type cabinet

3.7 Status display by self-diagnostic function (DGN)

The status of the NC/machine tool interface and of the interior of the NC can be displayed on the MDI & CRT unit. Also output signals from the NC to the machine tool can be transferred in simulation.

3.7.1 Operational procedure

- (1) Press the function button **DGNOS**. Diagnostic data will be displayed on the screen. '0' on the screen means contact is open, '1' is close.
To change the screen, follow one of the following two ways.
 1. Pressing PAGE **↓** moves the screen forward.
Pressing PAGE **↑** moves the screen backward.
 2. Press ADDRESS **N**, then key in the **diagnose number** by DATA keys and press **INPUT**. That diagnose number will be displayed.

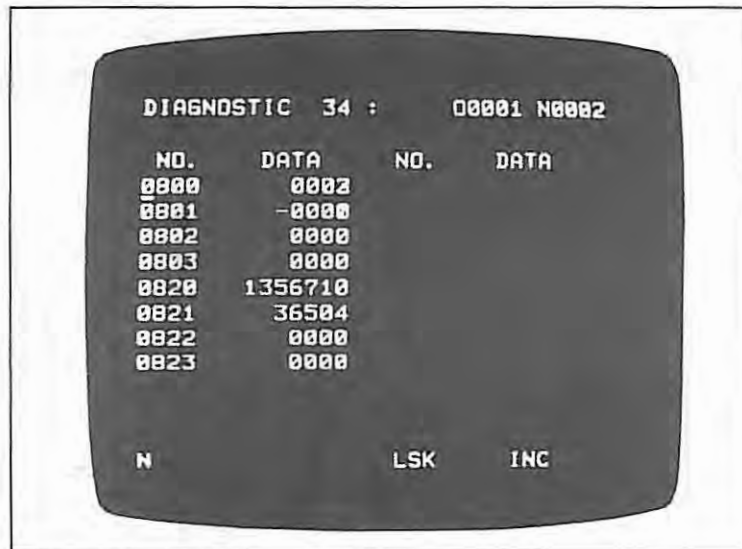

DGN screen (example)

The procedure to send output signals from NC to machine tool is as follows:

- (1) Select the MDI mode on the operator's panel.
- (2) Set '1' to 'DGNE' is parameter 010.
- (3) Let the diagnostic data to be output display by the above operation.
- (4) Move the cursor to the diagnostic number by using
CURSOR CURSOR
↑ or **↓**
- (5) Press **P** and **I** and/or **O** via the DATA key as many times as to set 8 bit data.
(Here 0 means output contact open; 1 output contact closed.)
Pressing the **CAN** key cancel the set data.
- (6) Press **INPUT** key. The data will be issued.
- (7) If these checking are finished, return the parameter to previous data. (DGNE = 0)

Notes on I/O signals

- (1) Output is possible only when DGNE = 0 in parameter 010.
- (2) When sending the output signals by using this function, group numbers from 064 to 095 should be used instead of from 000 to 031.
- (3) The condition of the output signal must be returned to the previous state.
- (4) The following output signals cannot be output by this function.
 - (i) "RWD" Rewind signal
This signal is output by rewinding the reel of the tape reader.
 - (ii) "DST" MDI start signal
This signal is output by actuating the START button on the MDI panel.

(iii) "R01 ~ R12"

When optional 12-bit-binary output is equipped, these signals cannot be output. These signals are output by 4-digit S code command.

3.7.2 Display Contents

DGN Table

Display contents		
DGN	Without Programmable Controller	With Programmable Controller
000~	Output signal to machine side	Output signal to machine side (Programmable Controller output signal)
032~	Input signal from machine side	Input signal from machine side (Programmable Controller input signal)
064~		Output signal to Programmable Controller
096~		Input signal from Programmable Controller
158	Programmable Controller B*(PC-B) control software version number	
159	Programmable Controller B (PC-B) operation flag	
160	Programmable Controller B (PC-B) ROM parity error contents	
161	Programmable Controller B (PC-B) ROM's presence check	
245	Programmable Controller type	
700	Status display when NC looks not operating during automatic operation	
701	Status display when NC looks not operating during automatic operation	
702	Status display concerning bubble memory	
703	Status display concerning tape reader	
706	External position display reset signal	
707	X/Z-axis OH, OVL and servo ready signal. Resolver/inductosyn PCB's presence or absence	
708	RAM board for PC-MODEL A presence or absence	
712	Automatic operation stop/hold status display	
713	X-axis DC motor feedback signal	
714	Position coder feedback signal, Manual pulse generator input signal	
800	X-axis position deviation	
801	Z-axis position deviation	
820	Machine position from X-axis reference point	
821	Machine position from Z-axis reference point	

*PC-B means FANUC PC-MODEL B (Programmable Controller)

PC-PARAMETER Display Contents (associated with Programmable Controller)

DGN	Display contents				
000~	Output signal to machine side (Machine ← Programmable Controller)				
032~	Input signal from machine side (machine → Programmable Controller)				
064~	Input signal from NC (Programmable Controller ← NC)				
096~	Output signal to NC (Programmable Controller → NC)				
200 231 263	<table border="0"> <tr> <td style="border: none;">}</td> <td style="border: none;">PC-MODEL A control relay status</td> </tr> <tr> <td style="border: none;">}</td> <td style="border: none;">PC-MODEL B control relay status</td> </tr> </table>	}	PC-MODEL A control relay status	}	PC-MODEL B control relay status
}	PC-MODEL A control relay status				
}	PC-MODEL B control relay status				
560 596 639 735	<table border="0"> <tr> <td style="border: none;">}</td> <td style="border: none;">PC-MODEL A nonvolatile memory status</td> </tr> <tr> <td style="border: none;">}</td> <td style="border: none;">PC-MODEL B nonvolatile memory status</td> </tr> </table>	}	PC-MODEL A nonvolatile memory status	}	PC-MODEL B nonvolatile memory status
}	PC-MODEL A nonvolatile memory status				
}	PC-MODEL B nonvolatile memory status				

- Note 1: Refer to each Programmable Controller ladder diagram for details of the above display contents.*
Note 2: The above contents are displayed on PC-PARAMETER screen. Refer to Appendix 16 for operation.

Without Programmable Controller

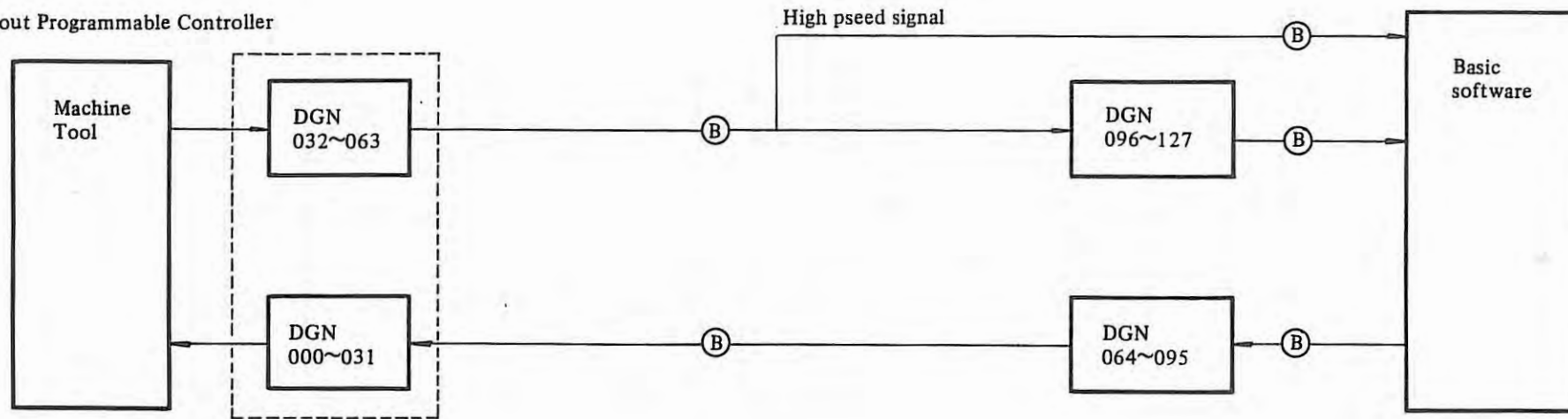

With FANUC PC-MODEL A or B

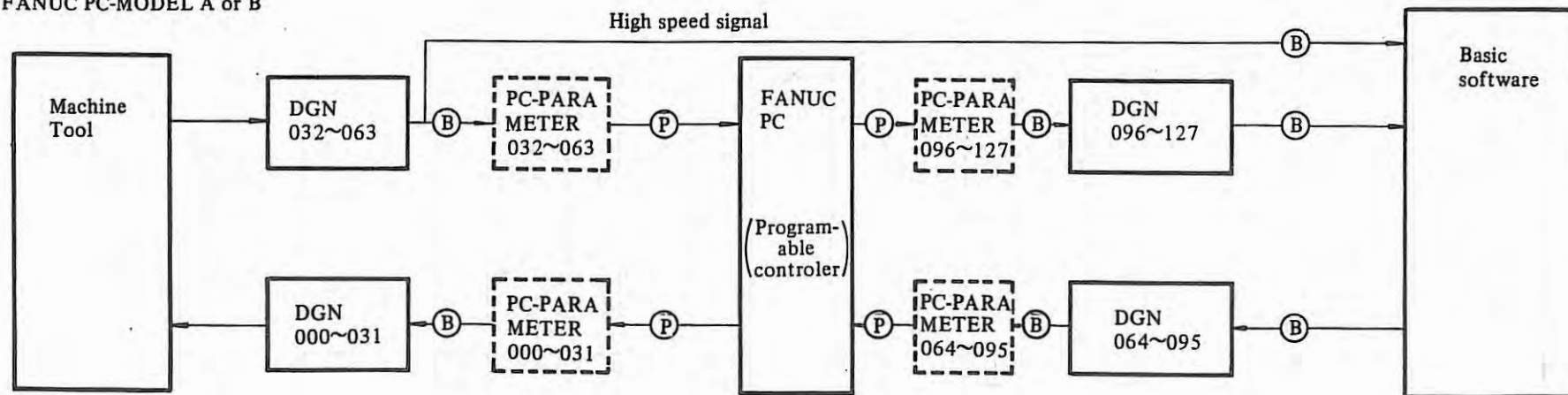

- Note 1) [---] is provided only in the case of FANUC PC-MODEL B.
 2) B → Shows the process by Basic Software.
 3) P → Shows the process by PC (Programmable Controller) Software.
 4) High speed signal includes emergency signal, overtravel signal, external deceleration, skip signal, deceleration signal for reference point return signal.

List of I/O signals

0	0	0	OP	SA	STL	SPL			ZPZ	'ZPX
			Cycle operation C04 (32)	Servo ready C04 (45)	Start lamp C04 (33)	Stop lamp C04 (1)			Reference point return finish C04 (20) C04 (35)	
0	0	1	MA	M30	M02	M00	DEN	RWD	RST	AL
			Control unit ready C04 (43)	End of tape C04 (50)	End of program C04 (49)	Program stop C04 (48)	Distribution end C04 (26)	Rewind C04 (12)	Reset C04 (44)	Alarm C04 (34)
0	0	2			DST		TF	SF	M01	MF
					MDI start C04 (46)		F function code read C03 (49)	S function code read C03 (31)	Optional stop C04 (27)	M function code read C04 (41)
0	0	3	M28	M24	M22	M21	M18	M14	M12	M11
			C04 (40)	2nd digit of M code C04 (39) C04 (38)		C04 (37)	C04 (24)	1st digit of M code C04 (23) C04 (22)		C04 (21)
0	0	4	R08	R07	R06	R05	R04	R03	R02	R01
			Spindle speed code for constant surface speed control C05 (15) C05 (14) C05 (13) C05 (12) C05 (11) C05 (10) C05 (9) C05 (8)							
0	0	5			ZP2Z	ZP2X	R12	R11	R10	R09
			2nd reference point return end Spindle speed code for constant surface speed control C04 (9) C04 (10) C05 (19) C05 (18) C05 (17) C05 (16)							
0	0	6	S28	S24	S22	S21	S18	S14	S12	S11
			C03 (23)	2nd digit of S code C03 (24) C03 (25)		C03 (26)	C03 (27)	1st digit of S code C03 (28) C03 (29)		C03 (30)
0	0	7	T28	T24	T22	T21	T18	T14	T12	T11
			C03 (41)	2nd digit of T code C03 (42) C03 (43)		C03 (44)	C03 (45)	1st digit of T code C03 (46) C03 (47)		C03 (48)
0	0	8	U07	U06	U05	U04	U03	U02	U01	U00
			DO for custom macro C12 (32) C12 (45) C12 (33) C12 (1) C12 (5) C12 (36) C12 (20) C12 (35)							
0	0	9	U015	U014	U013	U012	U011	U010	U09	U08
			DO for custom macro C12 (43) C12 (50) C12 (49) C12 (48) C12 (26) C12 (12) C12 (44) C12 (34)							
0	1	0	EREND (REND)	(XSTB)			ESEND	(ZSTB)		
			External data read C11 (17) C11 (15)				External data search C11 (49) C11 (31)			
0	1	1								

0	1	2								
---	---	---	--	--	--	--	--	--	--	--

0	1	3								
---	---	---	--	--	--	--	--	--	--	--

0	1	4								
---	---	---	--	--	--	--	--	--	--	--

0	1	5								
---	---	---	--	--	--	--	--	--	--	--

0	3	2	HX	*SVFX	*DECX	*ITX	-X	+X	*-LX	*+LX
			Manual handle feed axis select	Servo off	Reference point return deceleration	Interlock	Feed axis & direction select		Overtravel	
			C02 (34)	C01 (28)	C02 (16)	C03 (34)	C02 (39)	C02 (24)	C02 (46)	C02 (45)

0	3	3	HZ	*SVFZ	*DECZ	*ITZ	-Z	+Z	*-LZ	*+LZ
			Manual handle feed axis select	Servo off	Reference point return deceleration	Interlock	Feed axis & direction select		Overtravel	
			C02 (35)	C01 (17)	C02 (17)	C03 (35)	C02 (38)	C02 (23)	C02 (48)	C02 (47)

0	3	4				STLK				
						Interrupt C03 (36)				

0	3	5								
---	---	---	--	--	--	--	--	--	--	--

0	3	6	MLK	DLK	PRC	OVC	SBK	BDT1	DRN	AFL
			Machine lock	Display lock	Position record	Override cancel	Single block	Optional block skip	Dry run	Auxiliary function lock
			C02 (9)	C02 (10)	C01 (16)	C01 (14)	C02 (27)	C02 (28)	C02 (7)	C01 (15)

0	3	7	ZRN	SRN		SAR	FIN	ST		MIX
			Reference point return	Program restart		Speed M, S, T arrival	function finish	Cycle operation start		Mirror image
			C02 (41)	C01 (50)		C03 (38)	C02 (13)	C02 (1)		C01 (30)

0	3	8	ERS	RRW	*SP	*ESP	GST	SPC	SPB	SPA
			External reset	Reset & rewind	Cycle operation panel	Emergency stop	Gear shift	Spindle override		
			C02 (14)	C03 (9)	C02 (2)	C02 (3)	C01 (47)	C01 (31)	C01 (48)	C01 (18)

0	3	9	RT	ROV2	ROV1	*OV16	*OV8	*OV4	*OV2	*OV1
			Manual rapid traverse	Rapid traverse override				Override		
			C02 (8)	C03 (40)	C03 (39)	C02 (12)	C02 (11)	C02 (44)	C02 (43)	C02 (42)

0	4	0	MP4	MP2	MP1	ZAE	XAE	SMZ	ABS	CDZ
			Incremental feed, Manual handle feed			Automatic tool offset		Error detect	Manual absolute	Chamfering
			C03 (10)	C03 (8)	C03 (7)	C03 (37)	C03 (22)	C03 (30)	C03 (31)	C03 (32)
0	4	1	KEY	EDT	MEM	T	D	J	HS	
			Program protect	EDIT mode select	Memory mode select	Tape mode select	MDI mode select	Jog feed select	Manual handle/step select	
			C02 (25)	C02 (40)	C02 (6)	C02 (20)	C02 (19)	C02 (5)	C02 (4)	
0	4	2	*SSTP	SOR			GR4	GR3	GR2	GR1
			Spindle stop	Spindle orientation		Gear ratio for constant surface speed control				
			C03 (13)	C03 (14)		C03 (19)	C03 (3)	C03 (2)	C03 (1)	
0	4	3		SKIP		WN16	WN8	WN4	WN2	WN1
			Skip			External work number search				
			C01 (4)		C01 (21)	C01 (36)	C01 (34)	C01 (3)	C01 (35)	
0	4	4								
0	4	5	BDT7		BDT6		BDT5	BDT4	BDT3	BDT2
			Optional block skip							
			C10 (35)		C10 (17)	C10 (38)	C10 (23)	C10 (48)	C10 (47)	
0	4	6								
0	4	7	UI7	UI6	UI5	UI4	UI3	UI2	UI1	UI0
			DI for custom macro							
			C09 (27)	C09 (42)	C09 (44)	C09 (46)	C09 (29)	C09 (41)	C09 (43)	C09 (45)
0	4	8								
0	4	9								
0	5	0			BDT9	BDT8				
			Optional block skip							
			C10 (2)		C10 (3)					
0	5	1								

0	5	2	ED7 (OF28)	ED6 (OF24)	ED5 (OF22)	ED4 (OF21)	ED3 (OF18)	ED2 (OF14)	ED1 (OF12)	ED0 (OF11)
			External data input							
			C11 (10)	C11 (8)	C11 (7)	C11 (37)	C11 (22)	C11 (6)	C11 (5)	C11 (4)
0	5	3	ED15	ED14	ED13	ED12	ED11	ED10	ED9	ED8
			External data input							
			C10 (25)	C10 (40)	C10 (6)	C10 (20)	C10 (19)	C10 (5)	C10 (4)	C10 (21)
0	5	4	ESTB (DERR)	EA6 (DEND)	EA5 (DIX)	EA4 (OFSN)	EA3 (OF38)	EA2 (OF34)	EA1 (OF32)	EA0 (OF31)
			External data input							
			C11 (13)	C11 (14)	C11 (21)	C11 (20)	C11 (19)	C11 (3)	C11 (2)	C11 (1)
0	5	5	UI15	UI14	UI13	UI12	UI11	UI10	UI9	UI8
			DI for custom macro							
			C09 (20)	C09 (4)	C09 (2)	C09 (21)	C09 (36)	C09 (34)	C09 (3)	C09 (35)

Output signal	0	6	4	OP	SA	STL	SPL			ZPZ	ZPX
				Cycle operation	Servo ready	Start lamp	Stop lamp			Reference point return finish	
Output signal	0	6	5	MA	M30	M02	M00	DEN	RWD	RST	AL
				Control unit ready	End of tape	End of program	Program stop	Distribution end	Rewind	Reset	Alarm
Output signal	0	6	6			DST		TF	SF	M01	MF
						MDI start		T function code read	S function code read	Optional stop	M function code read
Output signal	0	6	7	M28	M24	M22	M21	M18	M14	M12	M11
				2nd digit of M code				1st digit of M code			
Output signal	0	6	8	R08	R07	R06	R05	R04	R03	R02	R01
				Spindle speed code for constant surface speed control							
Output signal	0	6	9			ZP2Z	ZP2X	R12	R11	R10	R09
						2nd reference point return		Spindle speed code for constant surface speed control			
Output signal	0	7	0	S28	S24	S22	S21	S18	S14	S12	S11
				2nd digit of S code				1st digit of S code			
Output signal	0	7	1	T28	T24	T22	T21	T18	T14	T12	T11
				2nd digit of T code				1st digit of T code			
Output signal	0	7	4	EREND (REND)	(XSTB)			ESEND	(ZSTB)		
				External data input (External tool offset)	(External tool offset)			External data input	(External tool offset)		
Output signal	0	8	0	U07	U06	U05	U04	U03	U02	U02	U00
				DO for custom macro							
Output signal	0	8	1	U015	U014	U013	U012	U011	U010	U09	U08
				DO for custom macro							

Input signal	0	9	6	HX	*SVFX		*ITX	-X	+X		
				Manual handle feed axis select	Servo off signal		Interlock signal	Feed axis and direction selection			
Input signal	0	9	7	HZ	*SVFZ		*ITZ	-Z	+Z		
				Manual handle feed axis select	Servo off signal		Interlock signal	Feed axis and direction selection			
Input signal	0	9	8				STLK				
							Interrupt				
Input signal	0	9	9								
Input signal	1	0	0	MLK	DLK	PRC	OVC	SBK	BDT1	DRN	AFL
				Machine lock	Display lock	Position record	Override cancel	Single block	Optional block skip	Dry run	Auxiliary function lock
Input signal	1	0	1	ZRN	SRN		SAR	FIN	ST		MIX
				Reference point return	Program restart		Speed arrival	Auxiliary function finish	Cycle operation start		Mirror image
Input signal	1	0	2	ERS	R _{FW}	*SP	*ESP	GST	SPC	SPB	SPA
				External reset	Rewind & reset	Cycle operation pause status	Emergency stop	Gear shift	Spindle override		
Input signal	1	0	3	RT	ROV2	ROV1	*OV16	*OV8	*OV4	*OV2	*OV1
				Manual rapid traverse	Rapid traverse override		Override				
Input signal	1	0	4	MP4	MP2	MP1			SMZ	ABS	CDZ
				Manual handle feed			Incremental feed		Error detect	Manual absolute	Chamfering
Input signal	1	0	5	KEY	EDT	MEM	T	D	J	HS	
				Memory protect	Part program editing	Memory operation	Tape operation	MDI operation	Jog feed	Handle and step feed	
Input signal	1	0	6	*SSTP	SOR			GR4	GR3	GR2	GR1
				Spindle stop	Spindle orientation			Gear ratio for constant surface speed control			
Input signal	1	0	7				WN16	WN8	WN4	WN2	WN1
							External work number search				

1	0	8	R08I	R07I	R06I	R05I	R04I	R03I	R02I	R01I
---	---	---	------	------	------	------	------	------	------	------

1	0	9					R12I	R11I	R10I	R09I
---	---	---	--	--	--	--	------	------	------	------

1	1	0								
---	---	---	--	--	--	--	--	--	--	--

1	1	1								
---	---	---	--	--	--	--	--	--	--	--

1	1	2								
---	---	---	--	--	--	--	--	--	--	--

1	1	3								
---	---	---	--	--	--	--	--	--	--	--

1	1	4			BDT9	BDT8				
---	---	---	--	--	------	------	--	--	--	--

Optional block skip

1	1	5								
---	---	---	--	--	--	--	--	--	--	--

1	1	6	ED7 (OF28)	ED6 (OF24)	ED5 (OF22)	ED4 (OF21)	ED3 (OF18)	ED2 (OF14)	ED1 (OF12)	ED0 (OF11)
---	---	---	---------------	---------------	---------------	---------------	---------------	---------------	---------------	---------------

External data input

1	1	7	ED15	ED14	ED13	ED12	ED11	ED10	ED9	ED8
---	---	---	------	------	------	------	------	------	-----	-----

External data input

1	1	8	ESTB (DERR)	EA6 (DEND)	EA5 (DIX)	EA4 (OFSN)	EA3 (OF38)	EA2 (OF34)	EA1 (OF32)	EA0 (OF31)
---	---	---	----------------	---------------	--------------	---------------	---------------	---------------	---------------	---------------

External data input

1	1	9								
---	---	---	--	--	--	--	--	--	--	--

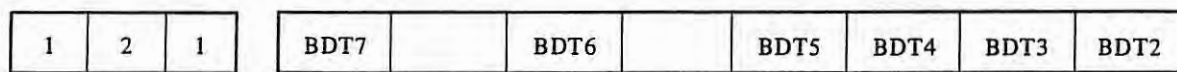
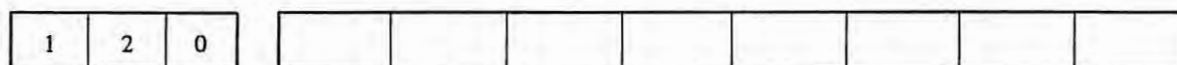

Optional block skip

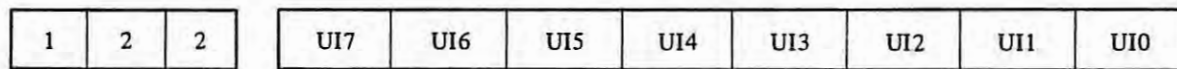

DI for custom macro

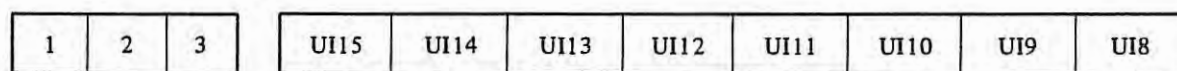

DI for custom macro

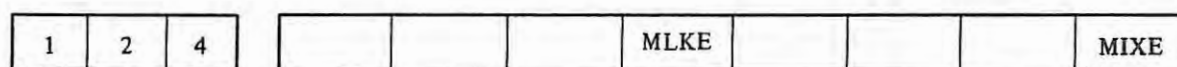

Note 1) (a) When movement is made with the machine lock signal (DGN No. 100-7) on, MIKE noted below is turned on. However, it will not be turned on, if it was already on when cycle start was applied.

(b) When movement is made in X-axis (except for cases where the mirror image is inoperative to axial movement) with the X-axis mirror image signal (DGN No. 101-0) on, MIXE noted below is turned on.

Note 2) Those turned on once, even if the signal is turned off or reset, the storage will not be turned off or the storage is cleared to zero when the power is turned on.

Note 3) In order to clear the storage without turning off the power, operate the DGNOS signal output in the MDI mode (PRM-011 bit 7 (DGNE) must be 1).

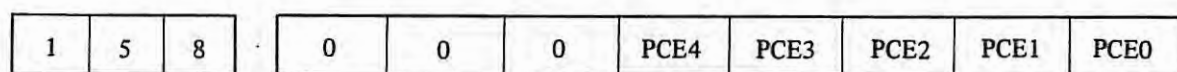
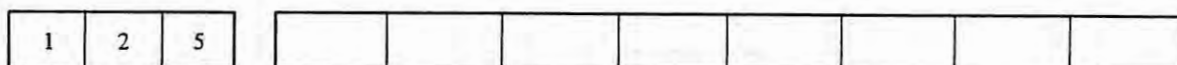

7 6 5 4 3 2 1 0

PCE0-4: Edition numbers A ~ Z of FANUC PC-MODEL B control software are displayed with values of 1-26 (binary).

Edition number	PCE4	PCE3	PCE2	PCE1	PCE0
A	0	0	0	0	1
B	0	0	0	1	0
C	0	0	0	1	1
D	0	0	1	0	0
E	0	0	1	0	1
F	0	0	1	1	0
⋮	⋮	⋮	⋮	⋮	⋮
⋮	⋮	⋮	⋮	⋮	⋮
Z	1	1	0	1	0

1	5	9
---	---	---

0	0	0	0	0	0	0	0	PCF
7	6	5	4	3	2	1	0	

PCF: When FANUC PC-MODEL B control program operates after the power is turned on, this signal becomes 1.

1	6	0
---	---	---

ROMP8	ROMP7	ROMP6	ROMP5	ROMP4	ROMP3	ROMP2	ROMP1
7	6	5	4	3	2	1	0

ROMP8-1: When PC ROM parity is wrong in FANUC PC-MODEL B, the bit corresponding to the actual address becomes 1.

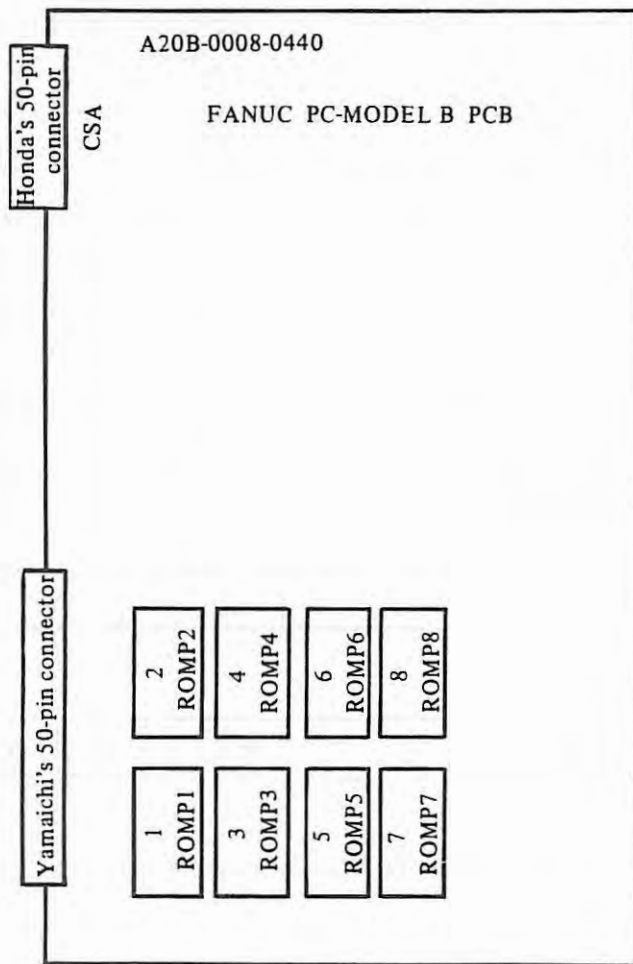

1 ~ 8 are indicated on the PCB.

1	6	1
---	---	---

						ROMP7 ROMP8	ROMP5 ROMP6	ROMP3 ROMP4
7	6	5	4	3	2	1	0	

ROM8-1: When a required ROM is not mounted in FANUC PC-MODEL B, the bit corresponding to a missing ROM becomes 1. Refer to the figure of diagnose number 160 for correspondence between ROM8-1 and the mounting positions.

	Mounting position
ROMP3	3
ROMP4	4
ROMP5	5
ROMP6	6
ROMP7	7
ROMP8	8

2	4	5
---	---	---

							PCB	PCA
7	6	5	4	3	2	1	0	

PCA~C: types of Programmable Controller

	PC-MODEL B	PC-MODEL A
Without Programmable Controller	0	0
With FANUC PC-MODEL A	0	1
With FANUC PC-MODEL B	1	0

7	0	0
---	---	---

	CST	CITL	COVZ	CINP	CDWL	CMTN	CFIN
7	6	5	4	3	2	1	0

When a digit is a 1, the corresponding status is effective.

- CFIN : M, S, or T function is being executed.
- CMTN : Move command in the cycle operation is being executed.
- CDWL : Dwell is being executed.
- CINP : In-position check is being executed.
- COVZ : Override is at 0%.
- CITL : STLK or Interlock is on.
- CST : The control is waiting for the speed arrival signal of the spindle to turn on.

7	0	1
---	---	---

		CRST				CTRD	
7	6	5	4	3	2	1	0

- CTRD : The control is reading the NC command from the tape reader.
- CRST : One of the following: emergency stop, remote reset, reset & rewind or the reset button on the MDI & DPL panel is on.

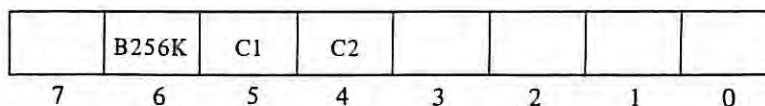
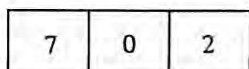

B256K, C1, C2: bubble memory capacity

Bubble memory capacity	B256K	C1	C2
15/20m	0	1	1
40m	0	0	1
80m	1	1	1
320m	1	0	0
320m	1	0	1
640m	0	1	0
1,280m	1	1	0

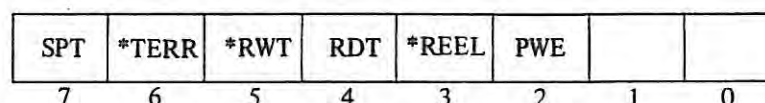
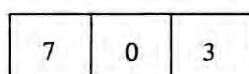

- SPT:** Shows the status of a tape reader sprocket (feed hole) signal. Becomes 1 at the position a feed hole is punched.
- *TERR:** Becomes 0 when an alarm is detected in the tape reader (is unused at present and consequently, 1 at all times).
- *RWT:** Becomes 0 while the tape reader with reels is rewinding tape.
- RDT:** Shows that the tape reader is ready to operate. Must be 1 for the tape reader to be started. Also becomes 1 when the AUTO/MANUAL switch of the tape reader (without reels) or the Reel ON/OFF switch (with reels) is set for automatic operation.
- *REEL:** Becomes 0 with the tape reader with reels; 1 with the tape reader without. Allows the NC to discriminate between the tape reader with reels and the tape reader without.
- PWE:** Shows the status of the Parameter Write-in switch on the master PCB. Becomes 1 with the switch turned down to ENABLE and 0 with it turned down to DISABLE.

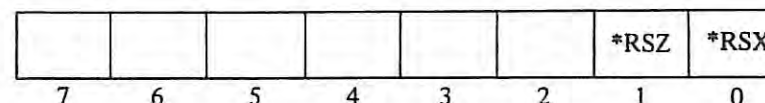
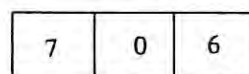

Reset signals of the external position display.

- *RSX:** X-axis reset signal (becomes 0 during reset).
- *RSZ:** Z-axis reset signal (becomes 0 during reset).

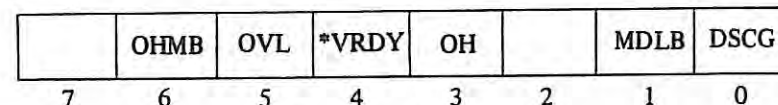
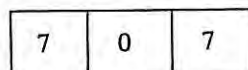

- OHMB:** Becomes 1 when an overheat alarm is detected on the master PCB.
- OVL:** Becomes 1 when an overload alarm is detected in the X/Y/Z-axis velocity control unit.
- *VRDY:** Becomes 0 when the X-, Y-, and Z-axis velocity control units are ready.
- OH:** Becomes 1 when an overheat alarm is detected in X/Y/Z-axis DC motor.
- MDLB:** Is 1 at all times.
- DSCG:** Becomes 1 when the resolver/inductosyn control PCB (A20B-0008-0460 or A20B-0008-0461) is mounted.

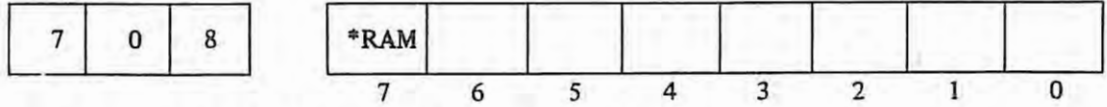

*RAM Becomes 0 when the RAM board of FANUC PC-MODEL A is mounted.

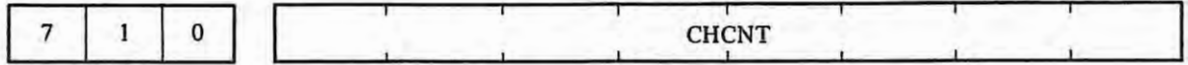

Data of the position of the character which caused the TH alarm when the TH alarm (No. 001) has generated.

If x is a decimal number which is converted from the binary number being displayed, the position of the character which caused the TH alarm is at the xth position from the EOB code which appears at first before the place where the tape is stopped.

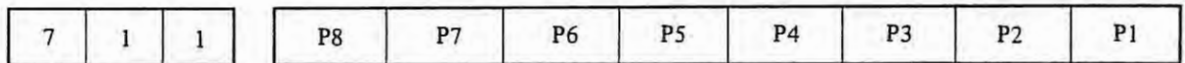
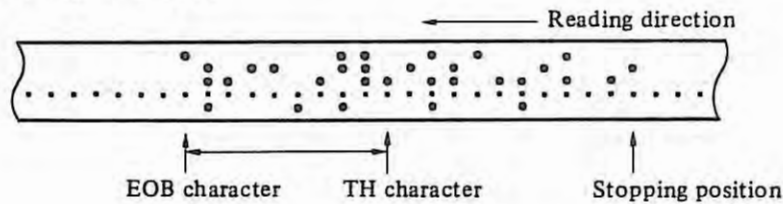

The code holes of the character which caused the TH alarm when the TH alarm (No. 001) was generated.

P1 corresponds to channel 1, P2 corresponds to channel 2 and so on. 0 means the hole is not punched. 1 means the hole is punched.

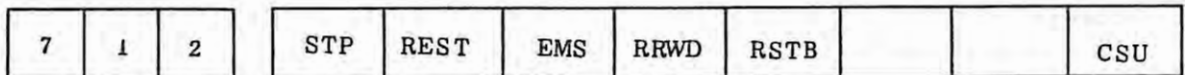

The state during cycle operation stop or cycle operation pause is confirmed. This is used for troubleshooting.

STP : The flag which stops the pulse distribution. This is set at the following conditions:

- (a) External reset or reset & rewind has been turned on.
- (b) Emergency stop has been turned on.
- (c) Feed hold has been turned on.
- (d) Reset button on the MDI & CRT is on.
- (e) The mode has been changed to the manual mode (JOG, STEP, HANDLE).
- (f) Alarm has been generated. (Some alarms may not set the flag.)

REST : This is set when one of the external reset, reset & rewind, emergency stop or reset button has been turned on.

EMS : This is set when the emergency stop has been turned on.

RRWD : This is set when the reset & rewind has been turned on.

RSTB : This is set when the reset button is on.

CSU : This is set when the emergency stop has been turned on or when the servo alarm has been generated.

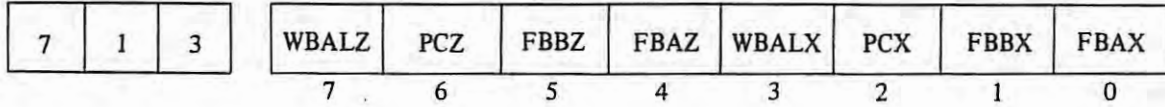

- WBALZ: Becomes 1 when the Z axis disconnection of pulse coder feedback signal check alarm occurs.
- PCZ: Z-axis pulse coder feedback one-rev signal.
- FBBZ: Z-axis pulse coder feedback signal phase B.
- FBAZ: Z-axis pulse coder feedback signal phase A.
- WBALX: Becomes 1 when the X-axis disconnection of pulse coder feedback signal check alarm occurs.
- PCX: X-axis pulse coder feedback one-rev signal (1 or 0 according to the figure below).
- FBBX: X-axis pulse coder feedback signal phase B (1 or 0 according to the figure below).
- FBAX: X-axis pulse coder feedback signal phase A (1 or 0 according to the figure below).

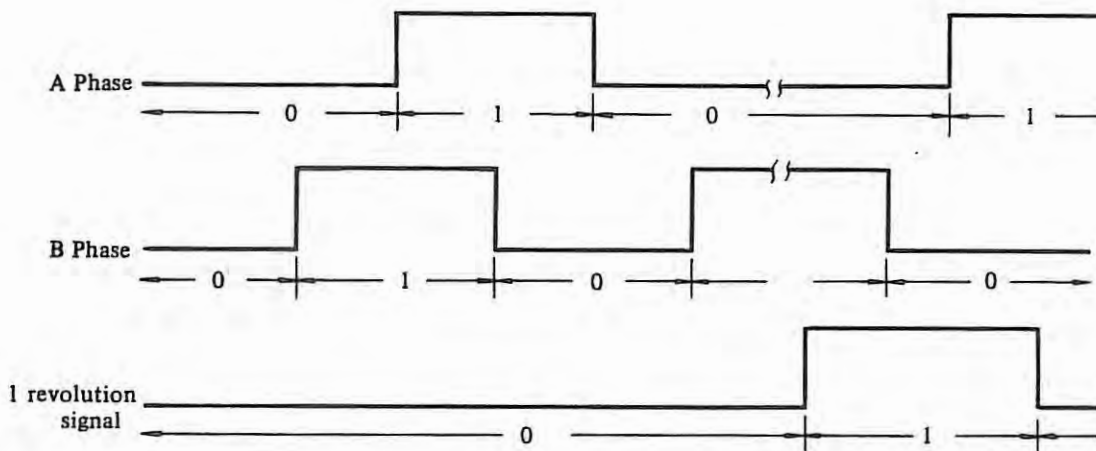

The figure above shows A- and B-phase waveforms in forward connection for +commands (motor CCW rotation).

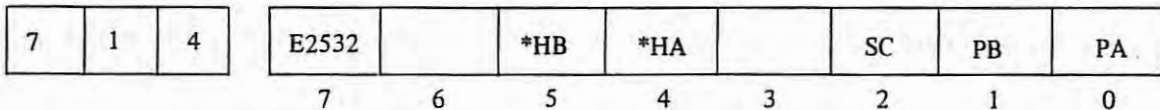

E2532: Becomes 1 when the PCB A20B-0008-0420 is mounted for control ROM; 0 when the PCB A20B-0008-480 is mounted.

*HB, *HA: manual pulse generator input pulses (1 or 0 according to the following figure).

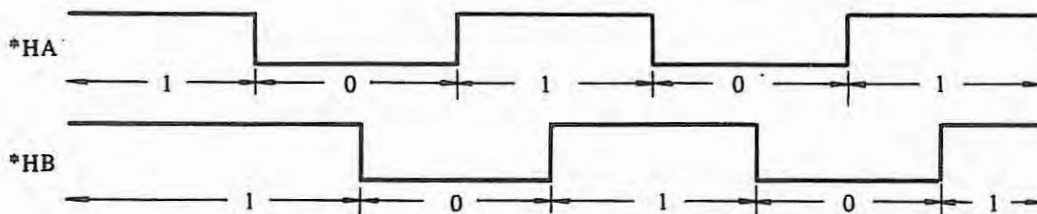

Both *HA and *HB are 1 at stoppage.

The figure above shows the waveforms when the manual pulse generator is turned in + direction. When it is turned in - direction, the phases of *HA and *HB become reverse.

- SC Position encoder feedback signal one-rev signal (see diagnose 713 for 1 or 0).
- PB Position encoder feedback signal phase B (see diagnose 713 for 1 or 0).
- PA Position encoder feedback signal phase A (see diagnose 713 for 1 or 0).

8	0	0	SVERRX (X axis)
---	---	---	-----------------

8	0	1	SVERRZ (Z axis)
---	---	---	-----------------

Position deviation value of X and Z axes in order.

8	0	5	Movement amount of X axis by handle interruption
---	---	---	--

8	0	6	Movement amount of Z axis by handle interruption
---	---	---	--

Unit: 0.001mm (metric system)
0.0001 inch (inch system)

8	2	0	ABSMTX (X axis)
---	---	---	-----------------

8	2	1	ABSMTZ (Z axis)
---	---	---	-----------------

Machine position from the reference point of X and Z axes in order.

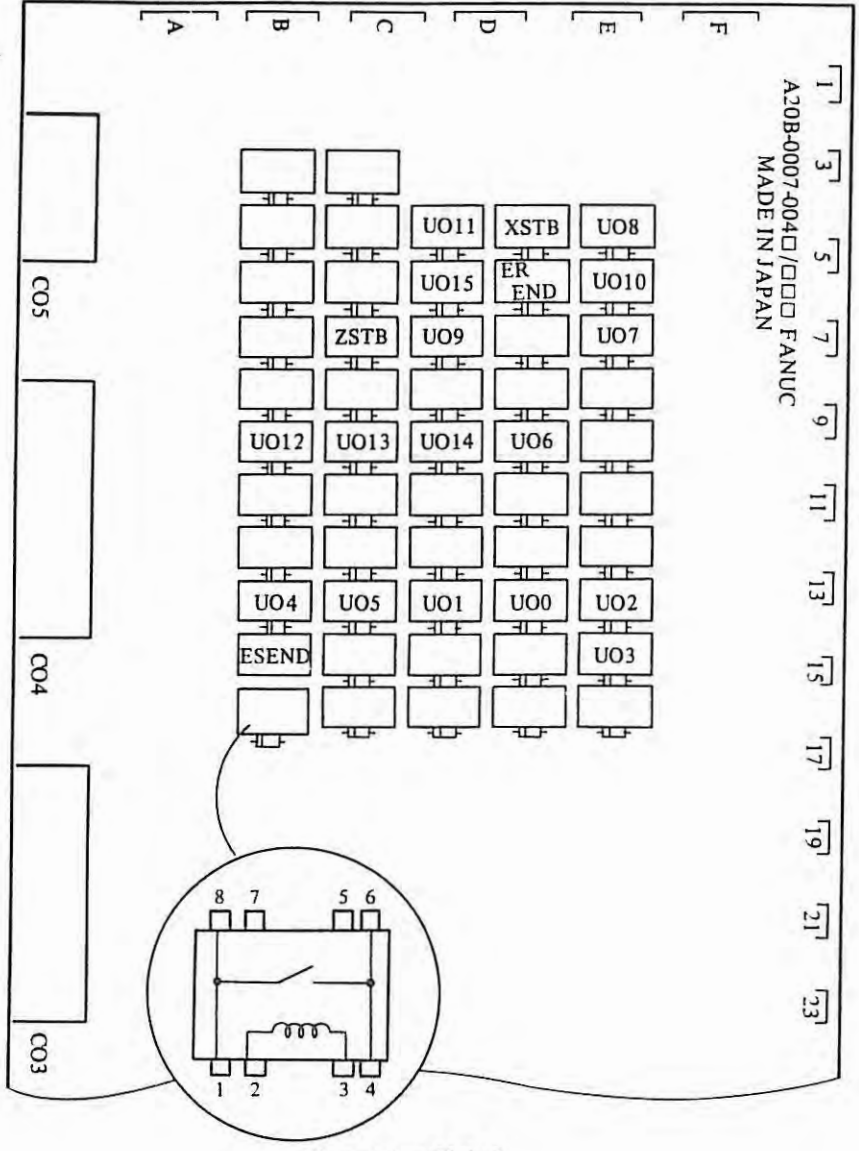
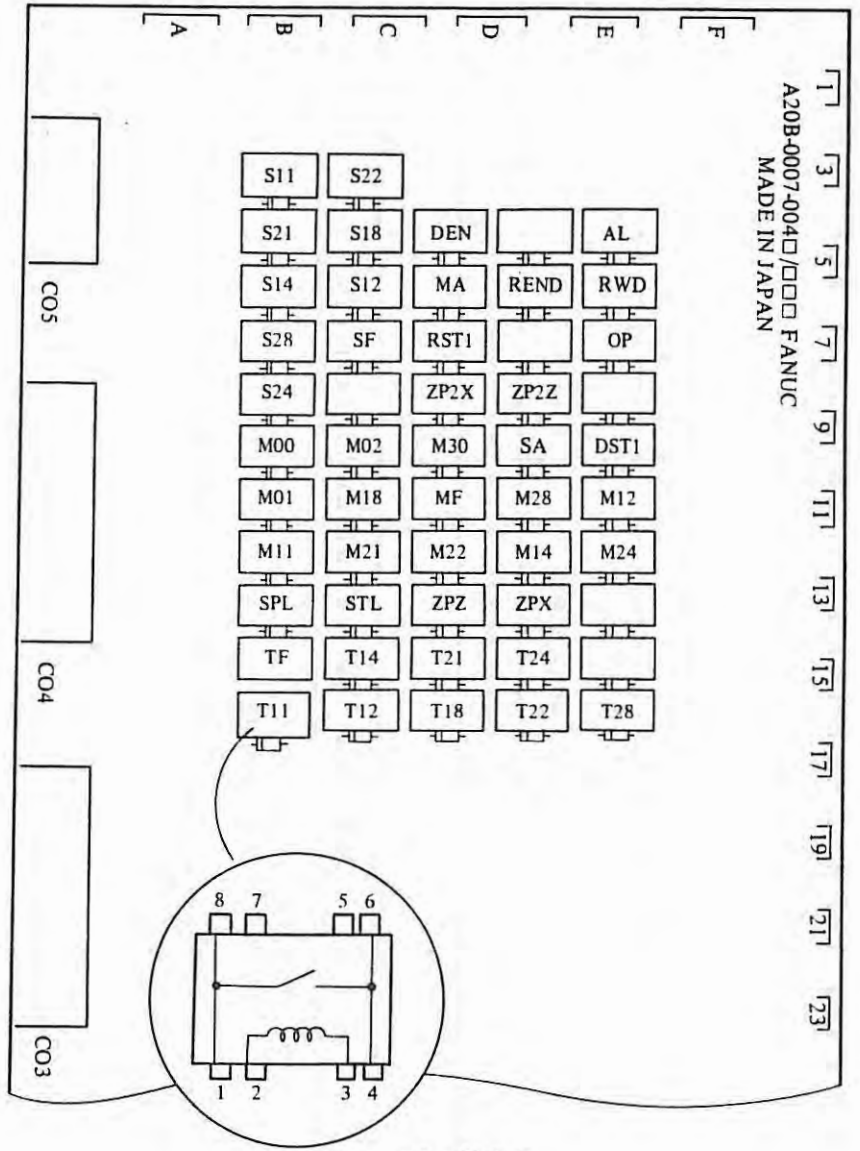

3.8 Block diagram of servo system

3.8.1 Block diagram of position control

(1) Pulse coder

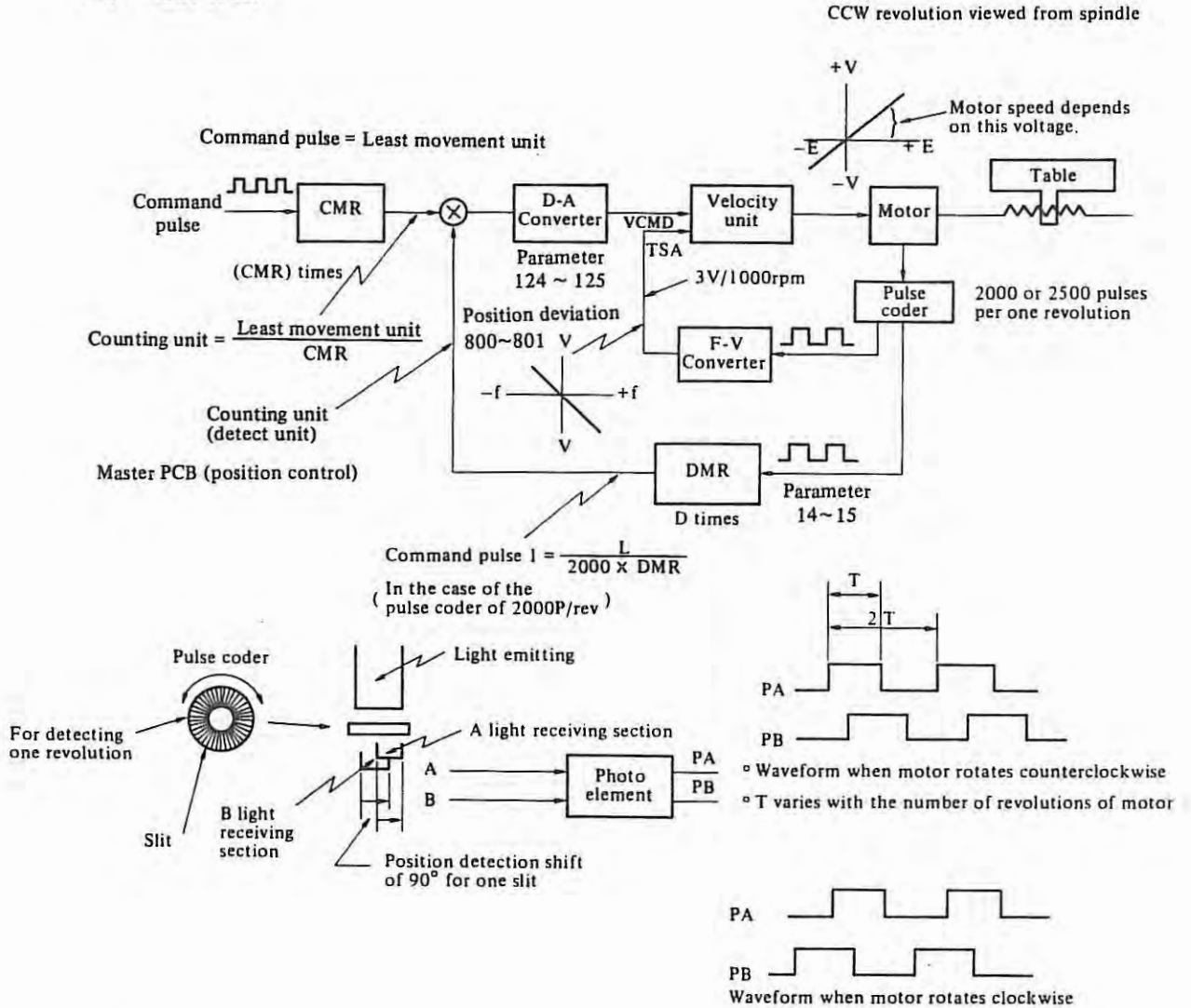

(2) Resolver/Inductosyn

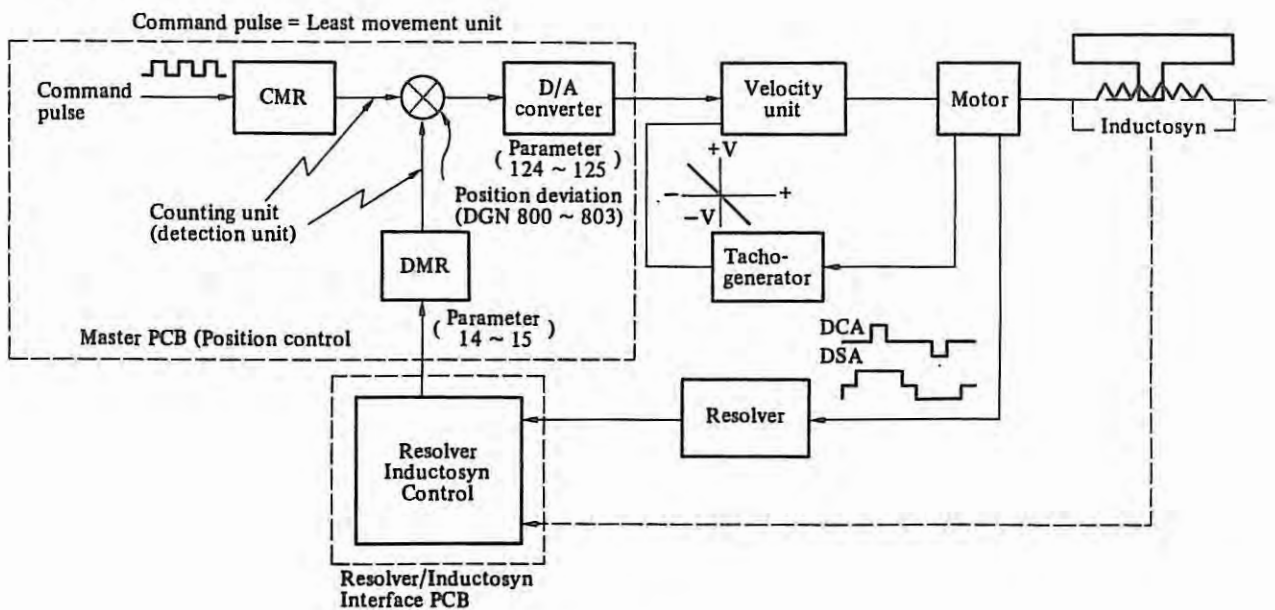

- CMR and DMR are the setting required to adjust the traverse of the table complying with the
 Command pulse: 0.001mm in metric system 0.0001 inch in inch system
 CMR : Command multiply ratio Parameter number 27, 28 (Standard value: 1)
 DMR : Detect multiply ratio Parameter number 14, 15 (Standard value: ½ for Resolver/
 Inductosyn)

L : Traverse (mm or inch) for one revolution of the motor

Counting unit: The value which is obtained by dividing the traverse for one revolution of the motor by the feedback pulse of (2000) × DMR (in the case of the pulse coder of 2000P/rev)

CMR and DMR are the setting to equalize the weight of the command pulse and feedback pulse for one pulse.

$$\text{Counting unit} : \frac{\text{Minimum movement unit (mm or inch)}}{\text{CMR}} = \frac{L \text{ (mm or inch)}}{\alpha \times \text{DMR}}$$

α : 2,000 p/rev, 2,500 p/rev for pulse coder
 4,000 p/rev for Resolver or Inductosyn.

ex. CMR is set to 1 and DMR to 2 when a movement distance is 4mm per 1 revolution of detector.

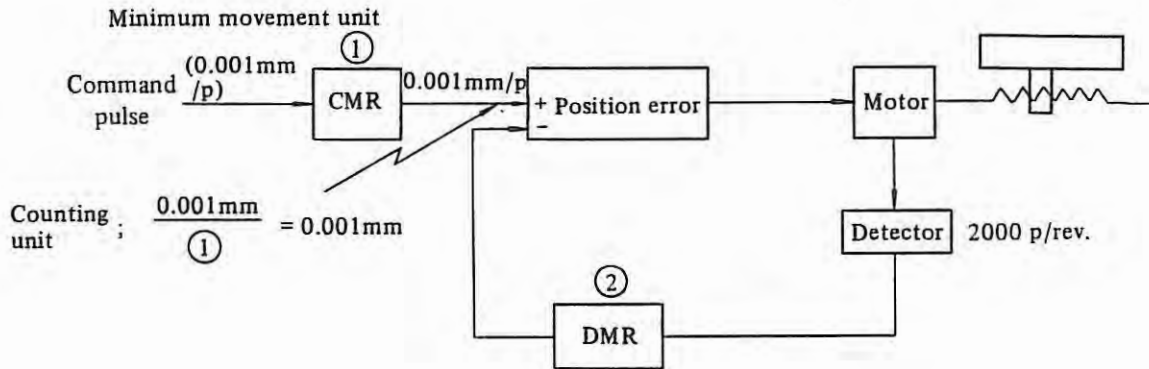

Counting unit ; $\frac{0.001\text{mm}}{\textcircled{1}} = 0.001\text{mm}$

detect unit ; $\frac{4\text{mm}}{2000 \times \textcircled{2}} = 0.001 \text{ mm}$

3.8.2 Block diagram of velocity control unit (H series)

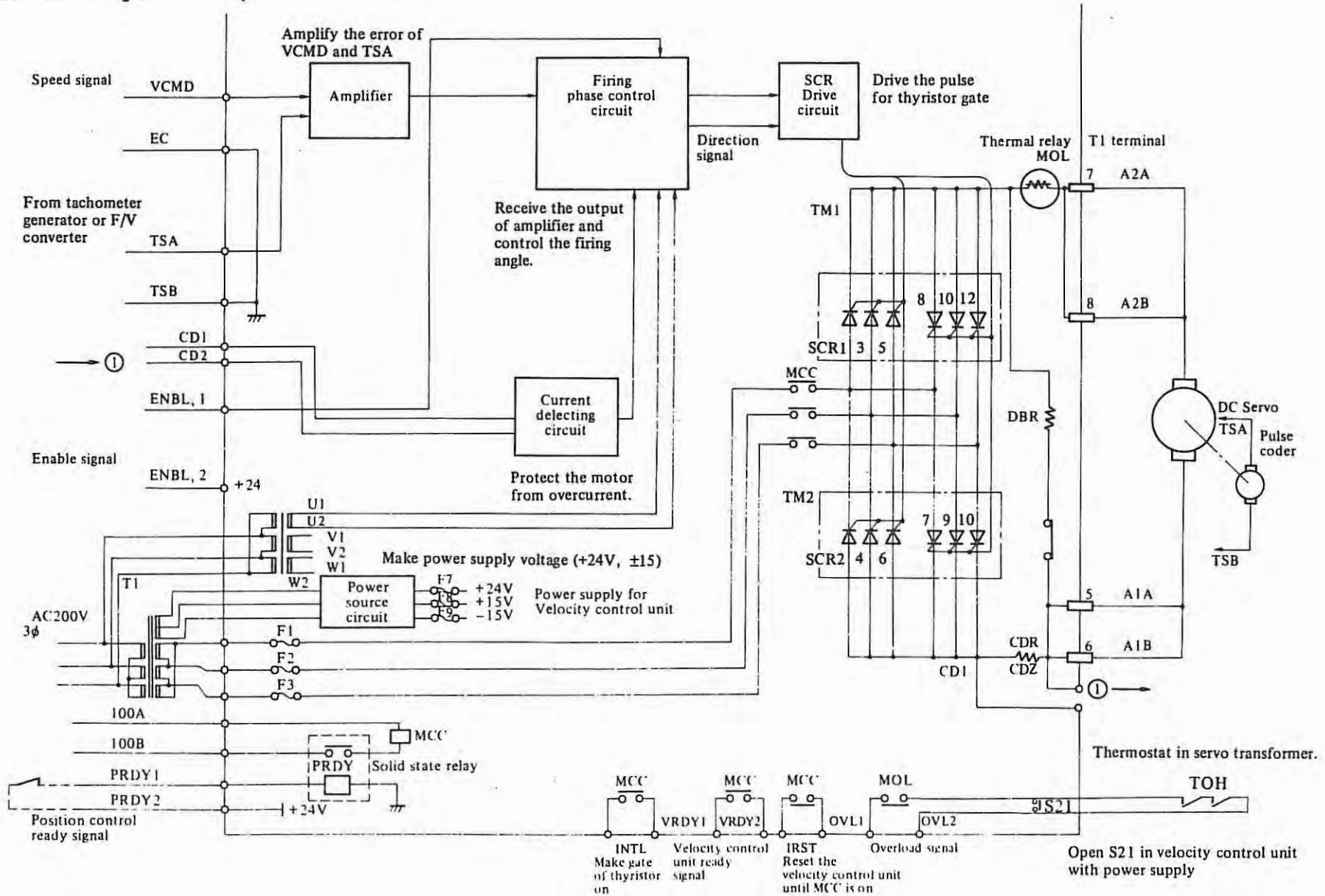

Block diagram (Explanation)

- (1) **Amplifier**
Amplifies the difference between velocity command signal (VCMD) and F/V converter output. (TSA).
- (2) **Firing phase control circuit**
Receiving the amplifier output signal, this circuit generates the firing control signal and direction signal.
- (3) **SCR driver circuit**
In response to the control pulse and direction signal, this circuit supplies drive pulses to the gate of SCR.
- (4) **Over-current detection circuit**
The motor current is sensed as a voltage drop across resistor R, and this circuit protects the motor from overcurrent.
- (5) **Power supply circuit**
The power supply circuit outputs +24V, +15V and -15V DC voltages for Velocity Control Units, from 18V × 2 windings of power transformer.

3.8.3 Connection on velocity control unit (Thyristor) (H series)

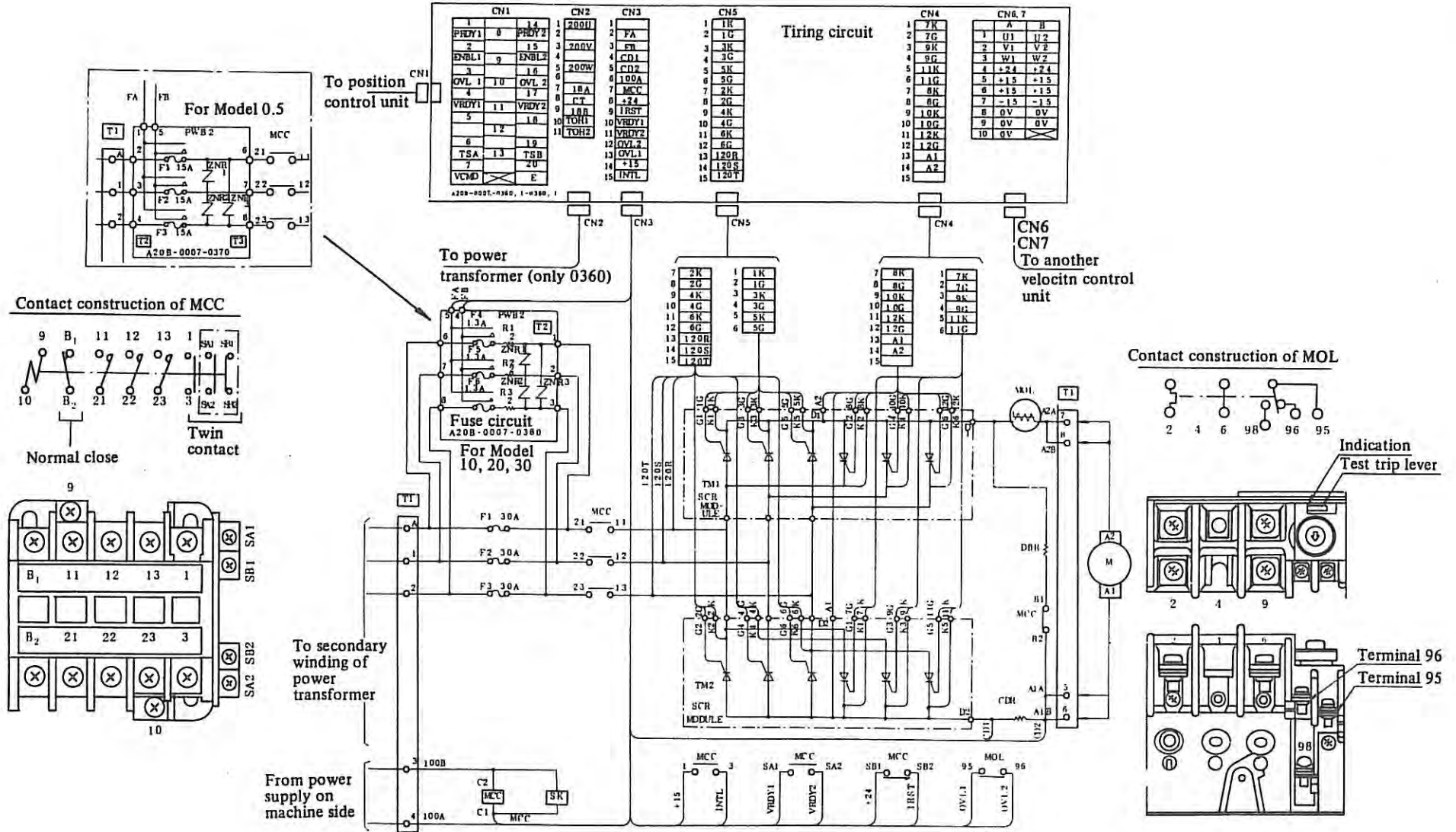

3.8.4 Block diagram of firing circuit (For Model 0, 5, 10, 20, 30) (H series)

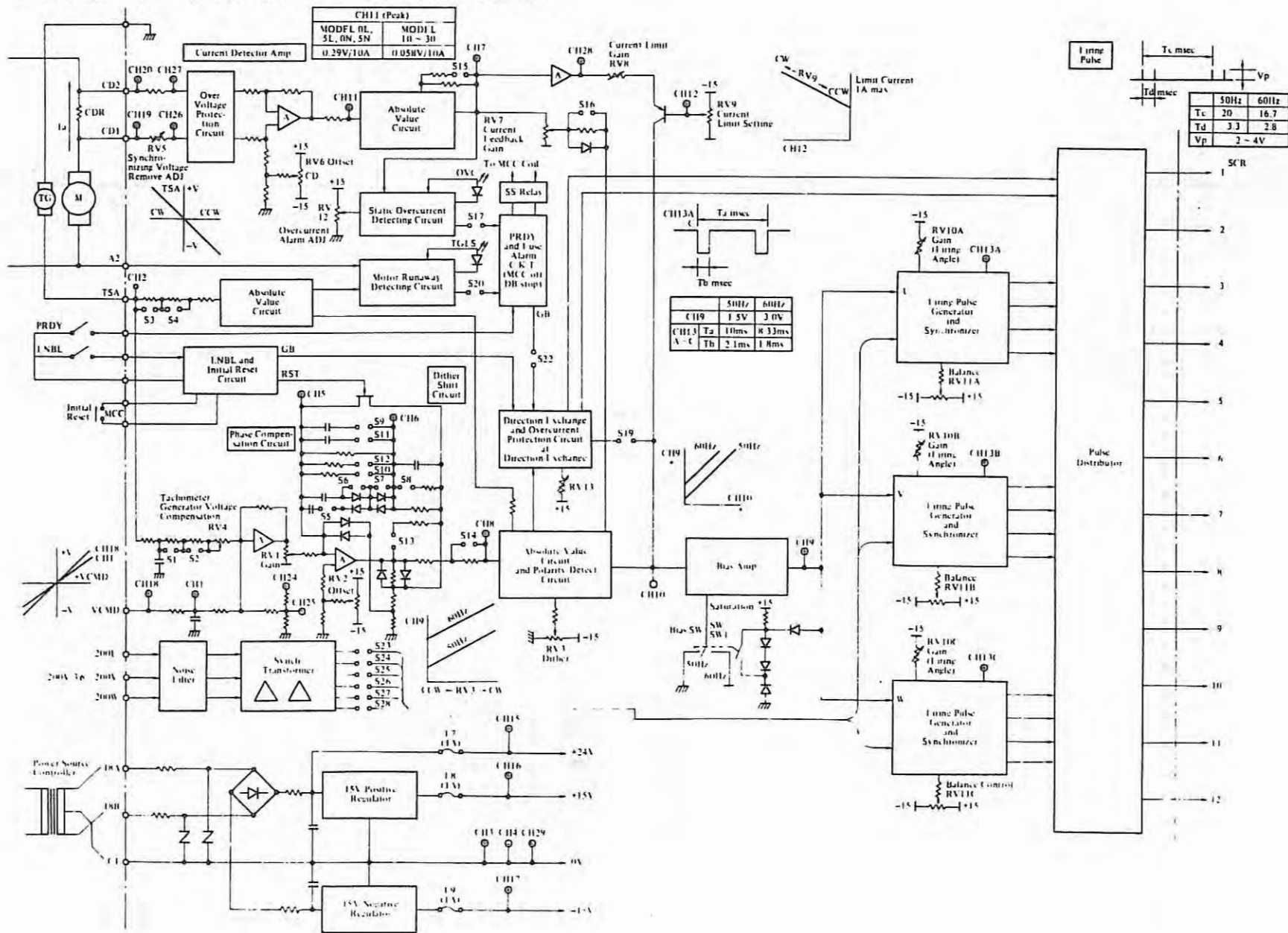

3.8.5 Block diagram of velocity control unit (M series)

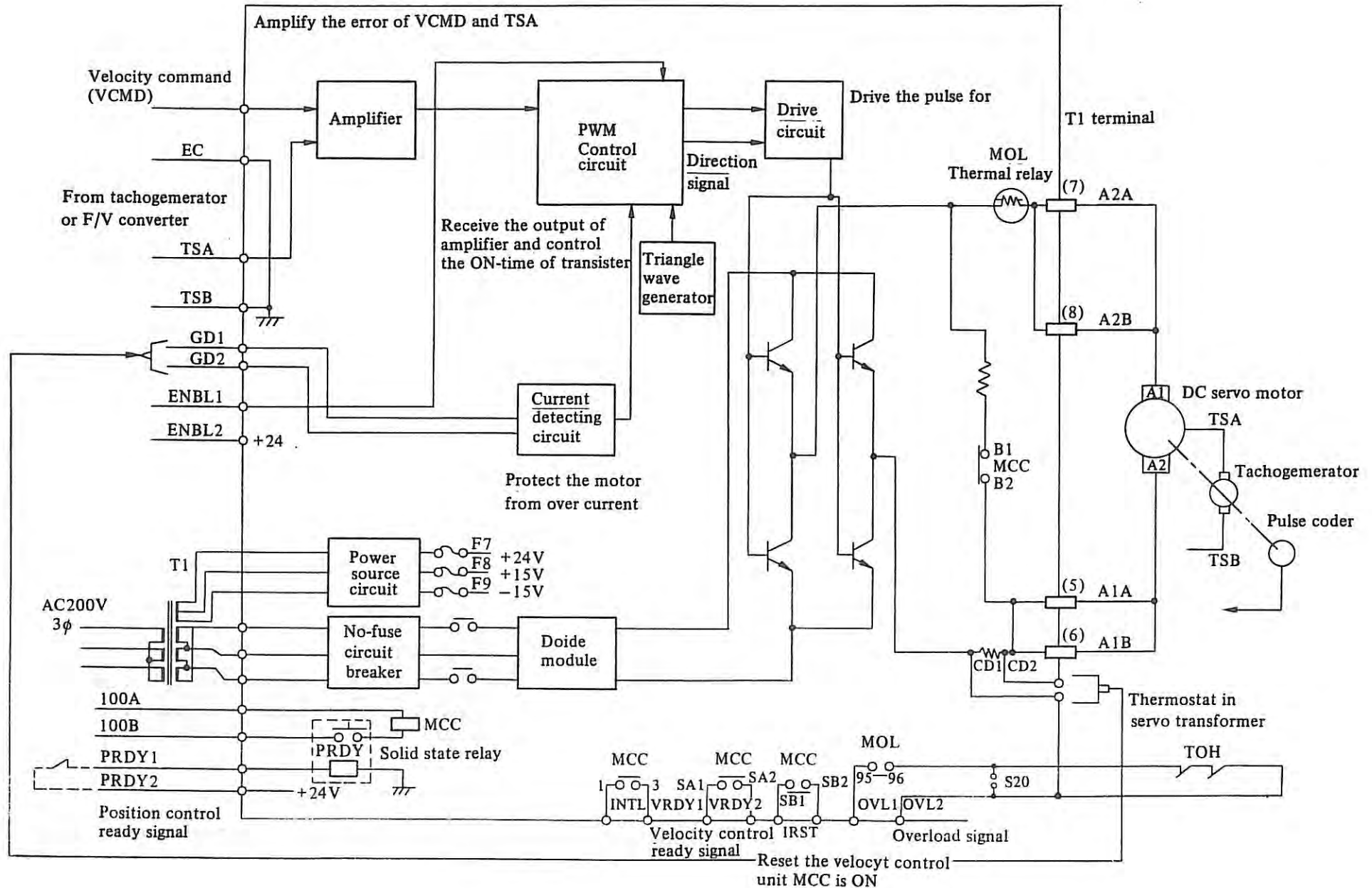

3.8.6 Connection diagram of velocity control unit model 00M (A06B-6047-H001)

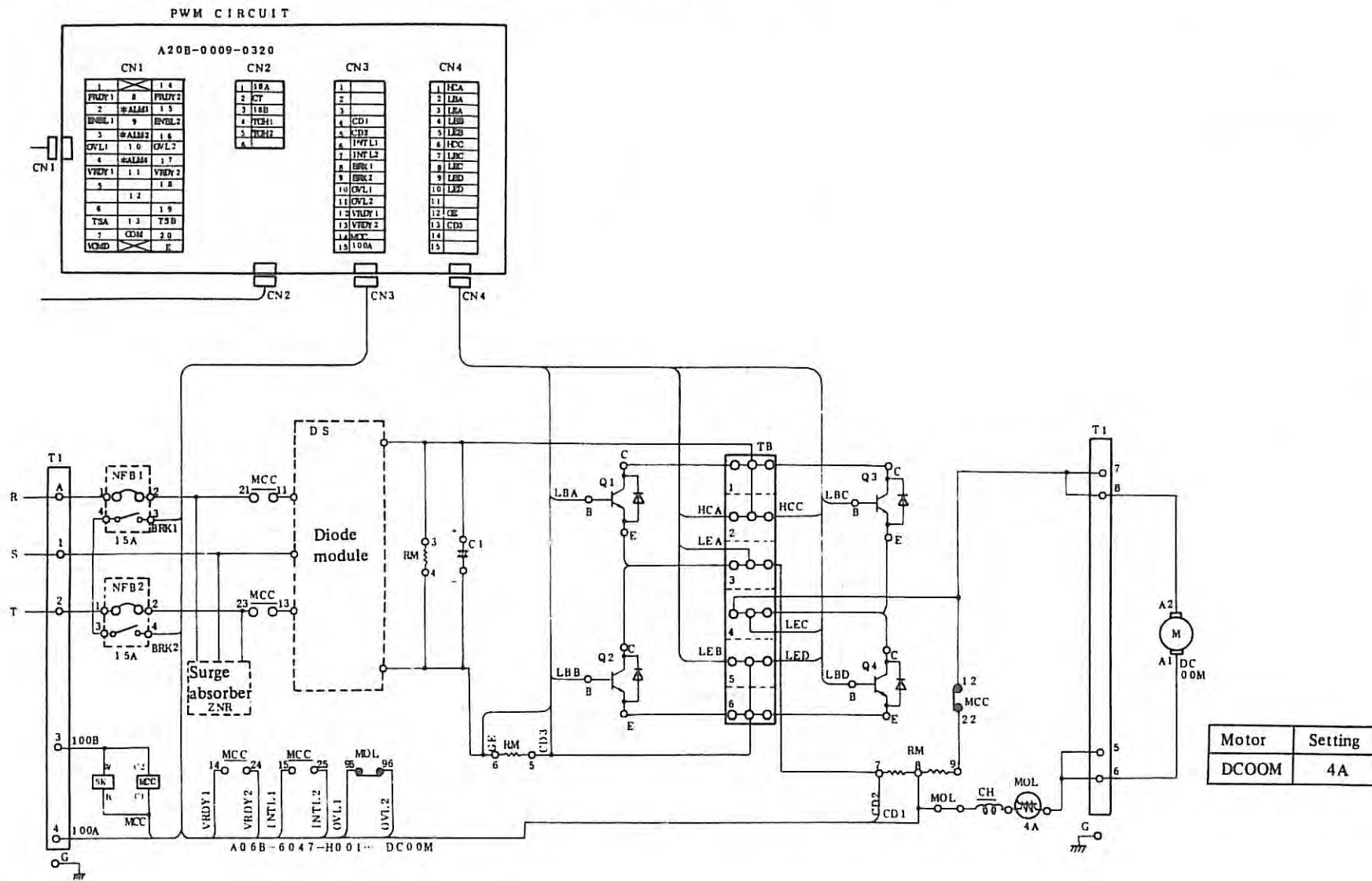

3.8.7 Connection diagram of velocity control unit model 10M ~ 30M (A06B-6047-H002 ~ 4)

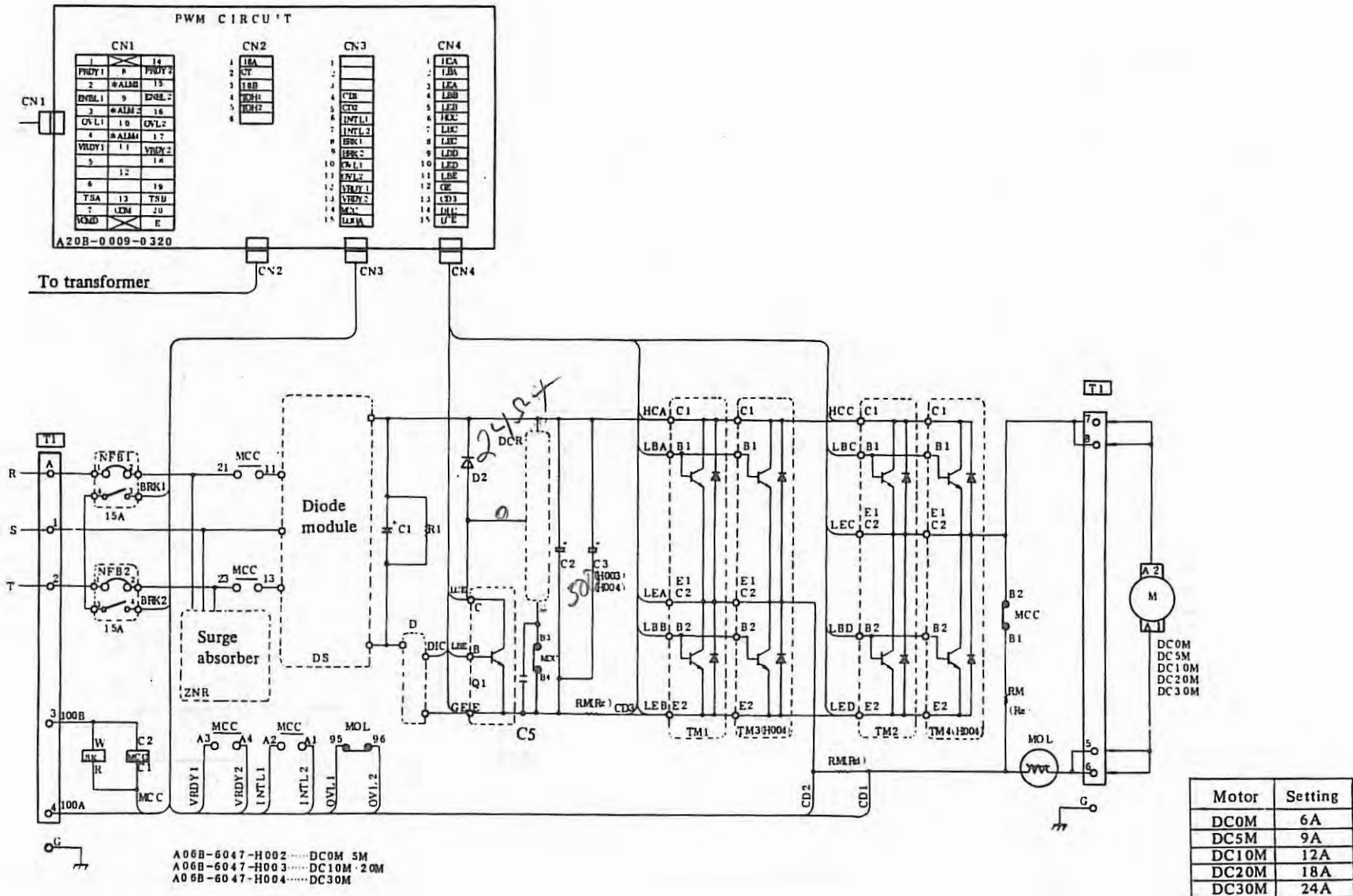

3.8.8 Connection diagram of velocity control unit model 10M ~ 30M with separate discharge circuit (A06B-6047-H040, H041)

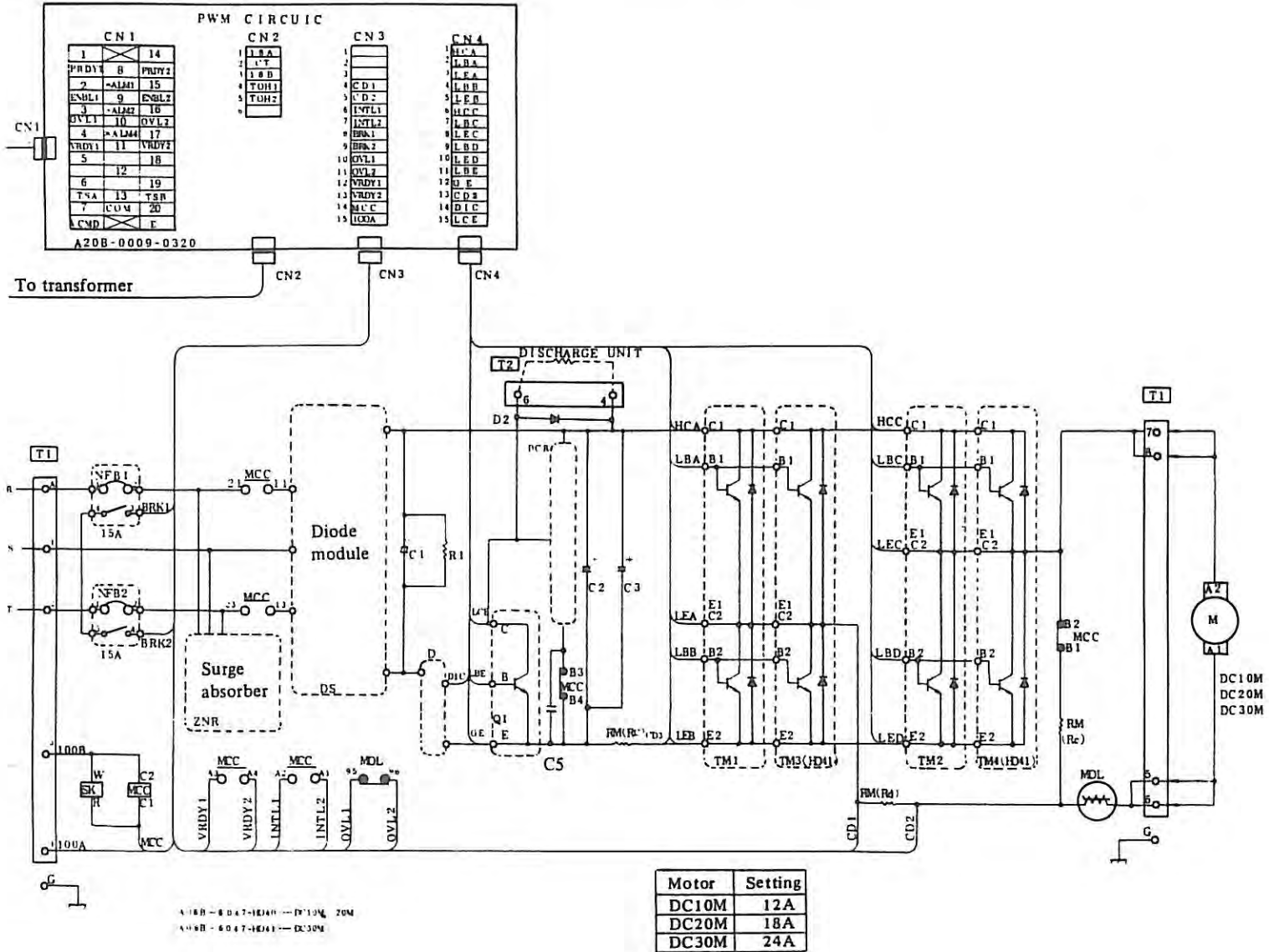

3.8.9 Connection diagram of velocity control unit model 30MH (A06B-6047-H005)

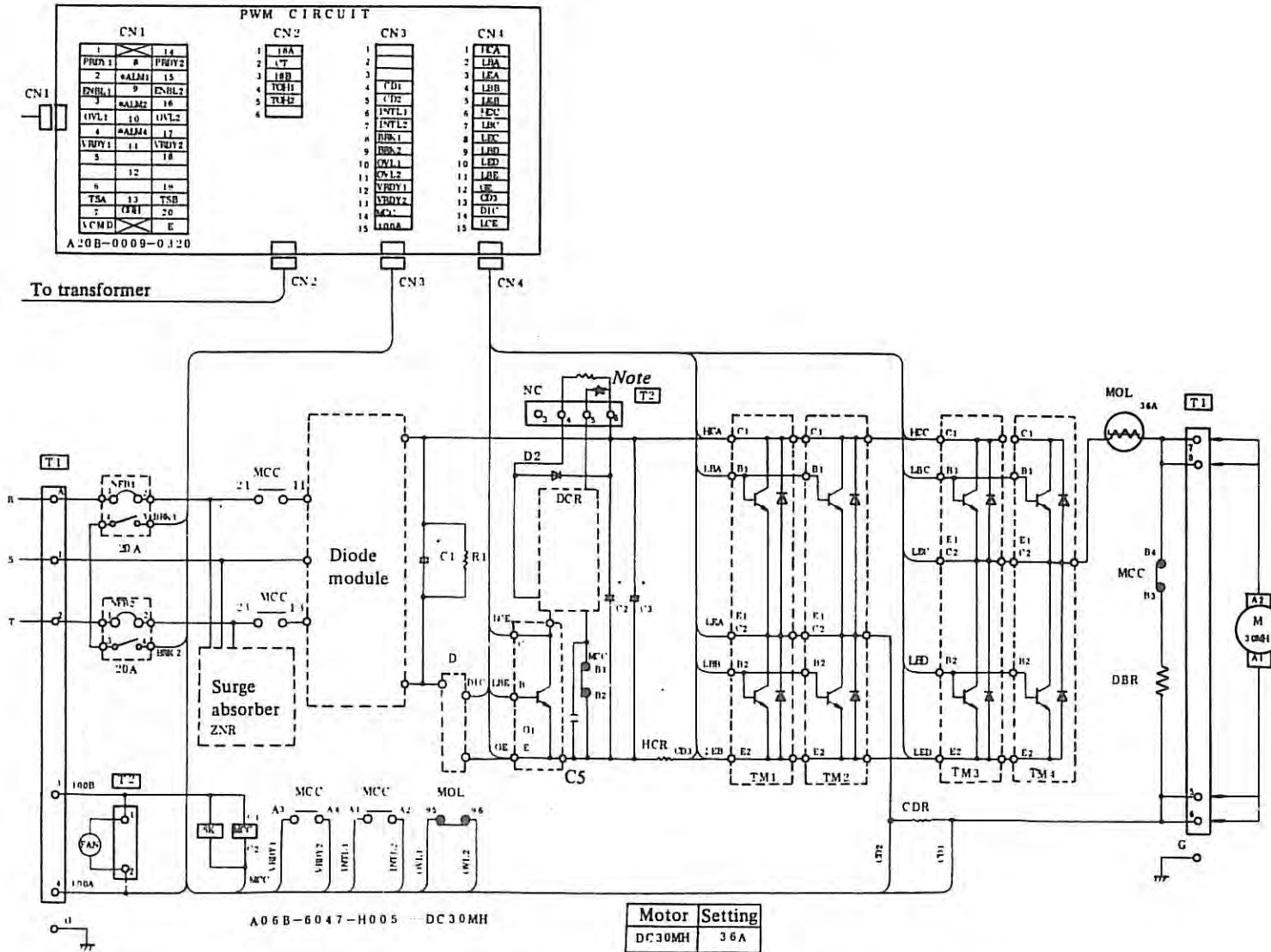

Note) Remove the short bar when the discharge unit is provided.

3.9 Confirmation of the connection between control and velocity control unit

3.9.1 Mounting position of connector and terminal on velocity control unit (H series)

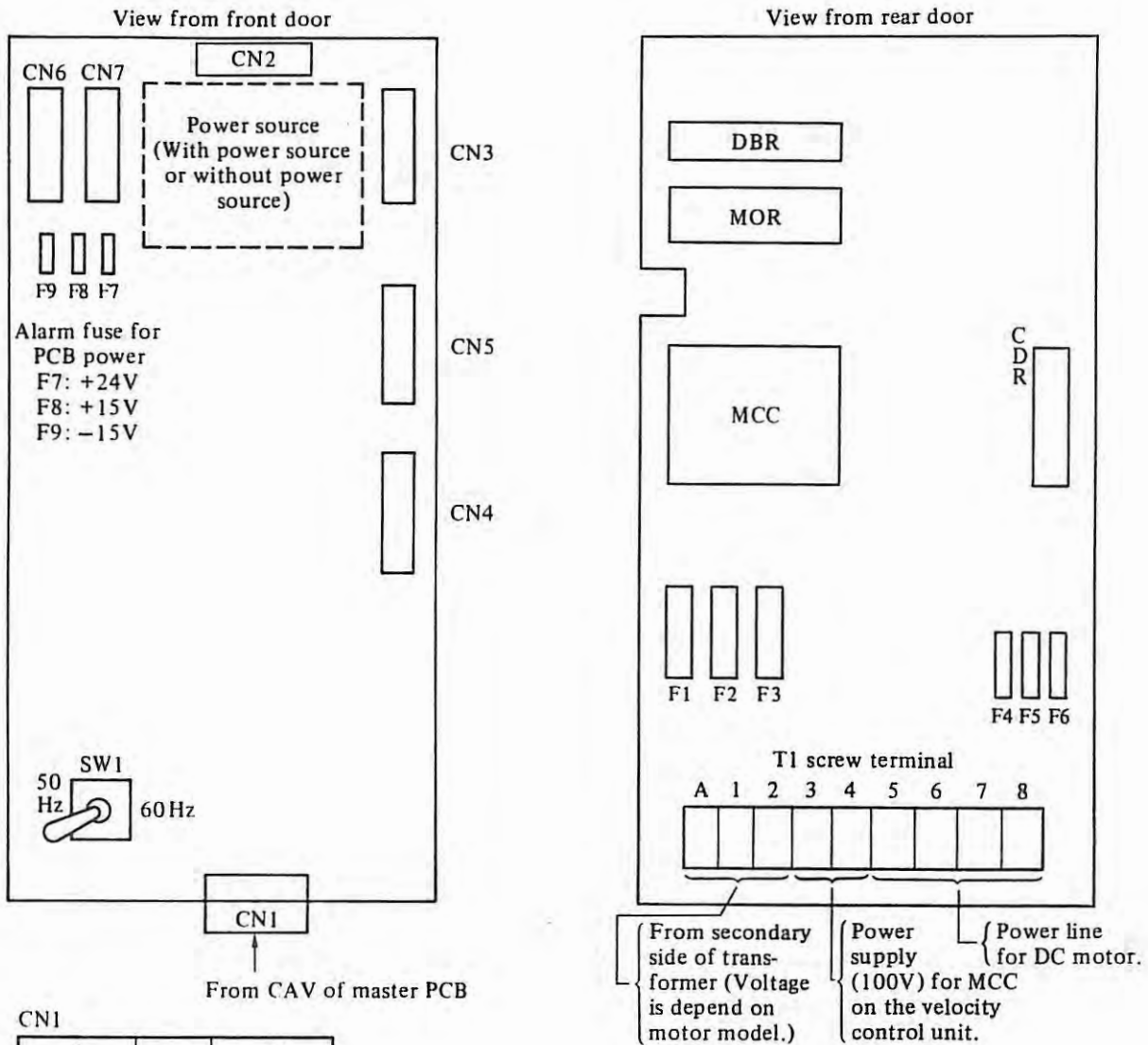





CN1

1		14
PRDY1		PRDY2
2	3	15
ENBL1		ENBL2
3	9	16
OVL1		OVL2
4	10	17
VRDY1		VRDY2
5	11	18
6	12	19
TSA		TSB
7	13	20
VCMD		E

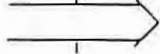
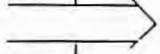
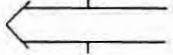
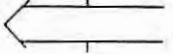
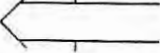
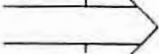
- PRDY1, 2: Position control ready signal.
- ENBL1, 2: Firing control signal.
- OVL1, 2: Overload signal.
- TSA, B: Tachogenerator feedback signal.
- VCMD: Velocity command signal.

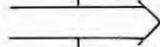
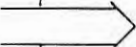
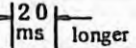
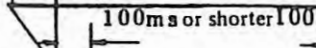
3.9.2 Descriptions of signals (H series)

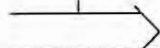
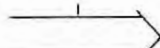
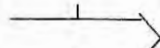
No.	Signal	Designation	Type	Significant level	No. of lines	Sending direction			Remark
						Control Unit	Velocity Control Unit	Servo Motor	
1	Position control READY signal	PRDY1 PRDY2	Contact	Contact ON	2				The power is supplied to Velocity control Unit when the contact signal turns ON. Dynamic braking is made for servo motor, when this signal turned OFF.
2	Firing control signal	ENBL1 ENBL2	Contact	Contact ON	2				Thyristors are fired when this contact signal is turned ON. The motor current is cut, but no dynamic braking is made when this signal turned OFF.
3	Overload signal	OVL1 OVL2	Contact	Contact OFF	2				An excessive motor current turns the contact OFF. The contact signal of verload relay.
4	Velocity control READY signal	VRDY1 VRDY2	Contact	Contact ON	2				The contact turns ON when the Unit is ready to operate.
5	Tachogenerator feedback signal (F/V convertor)	TSA TSB	Analog signal	A negative voltage with counterclock wise rotation of motor.	2				3V-1000 rpm. or 6V-1000 rpm.
6	Velocity command signal	VCMD E	Analog signal	A positive signal with counterclock wise rotation of motor.	2				7V/2000 rpm for model 0 or 5, and 7V/1000 rpm for model 10, 20, 30 10H, 20H or 30H.

No.	Signal	Designation	Type	Significant level	No. of lines	Sending direction			Remark
						Control Unit	Velocity Control Unit	Servo Motor	
7	Magnetic contactor power	100A 100B	100 ~ 115 VAC ±10%		2				Timing chart
8	DC servo motor drive signal	A1A A1B A2A A2B	0 ±60V 0 ±90V 0 ±120V 0 ±130V DC	A positive voltage on A1 line at clockwise motor rotation	4				<p>120R·S·T _____</p> <p>100A·B _____</p> <p>PRDY1·2 </p> <p>ENBL1·2 </p> <p>VRDY1·VRDY2 </p>
9	DC servo motor power	120R 120S 120T	60VAC 90VAC 120VAC 130VAC		3				
10	Synchronization signal	200U 200V 200W	200VAC		3				A signal to provide synchronization for thyristor gate signal and power supply.
11	Power input	18A 18B CT	18VAC		3				 <p>Power transformer secondary winding. Supplied to a printed circuit board for +24V, +15V and -15V DC powers.</p>

3.9.3 Total connection of servo system (H series)

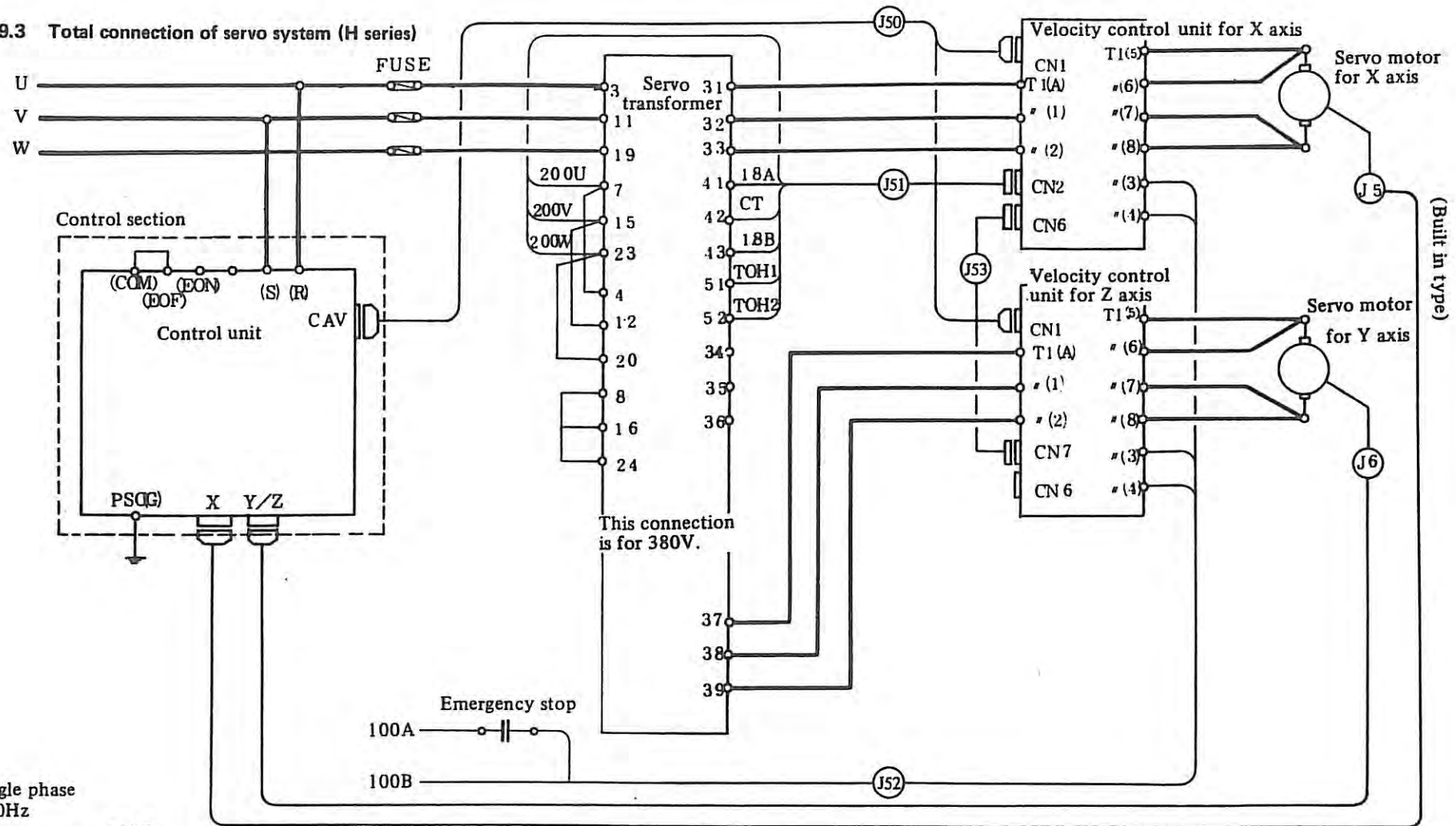

Single phase
• 50Hz

AC100 ~ 110^{+10%}_{-15%}

• 60Hz

AC100 ~ 115^{+10%}_{-15%}

50VA (25VA for 1 axis)
(Contactor coil load)

(Note 1) Servo transformer, velocity control units for X and Z axis, and control transformer should be installed at the machine side.

(Note 2) For the cable indicated by thick line, use the wire of its sectional area being 3.5mm² or more.

(Note 3) For the grounding (G), use the wire of its sectional area being 5.5mm² or more and grounding resistance must be below 100Ω.

(Note 4) For connecting cable J53, please order to FANUC.

Specification: A66L-2001-0440#20B0210

(Note 5) J50, J51, J52, other connecting cables and fuses should be prepared by the machine tool builder.

(Note 6) AC 100V for contactor coil should be prepared by the machine tool builder.

Control unit
CAV
MR-50RM

33		1
TSAL	X	VCMDL
34		2
TSAM	19	VCMDM
35		3
	20	
36	ECM	4
	21	ECL
37	SGM	5
	22	SGL
38		6
	23	
39		7
	24	
40		8
	25	
41		9
	26	
42	VRDYM	10
	27	VRDYL
43	E1M	11
	28	E1L
44	OVL M	12
	29	OVL L
45	E2M	13
	30	E2L
46	PRDYM	14
	31	
47	ENBLM	15
	32	
48	CRM	16
	X	PRDYL
49		17
	X	ENBLL
50		18
	X	CRL

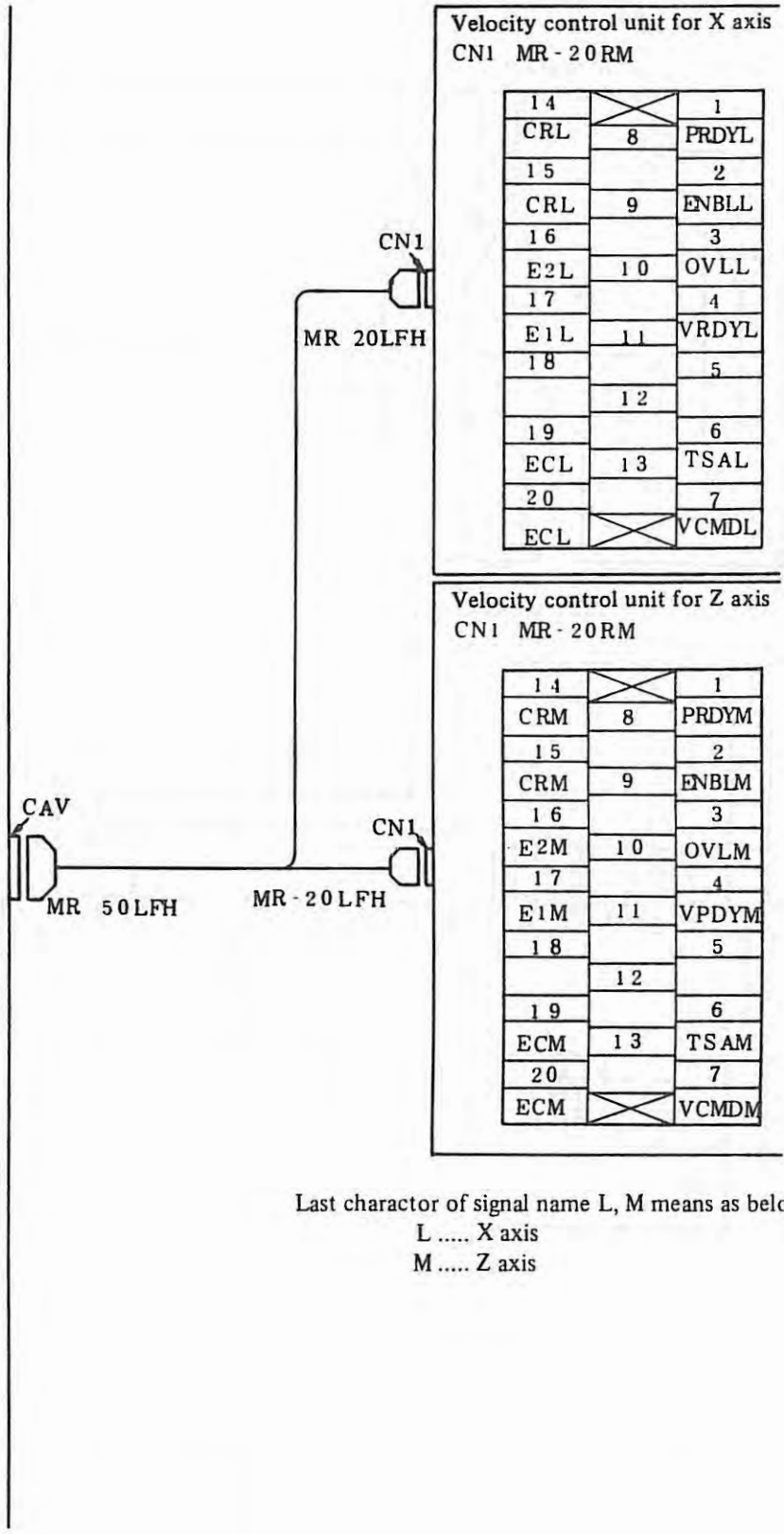

Velocity control unit for X axis
CN1 MR-20RM

14	X	1
CRL	8	PRDYL
15		2
CRL	9	ENBLL
16		3
E2L	10	OVL L
17		4
E1L	11	VRDYL
18		5
	12	
19		6
ECL	13	TSAL
20		7
ECL	X	VCMDL

Velocity control unit for Z axis
CN1 MR-20RM

14	X	1
CRM	8	PRDYM
15		2
CRM	9	ENBLM
16		3
E2M	10	OVL M
17		4
E1M	11	VPDYM
18		5
	12	
19		6
ECM	13	TSAM
20		7
ECM	X	VCMDM

Last character of signal name L, M means as below
L X axis
M Z axis

Fig. 3.9.3 (a) Connection of Cable

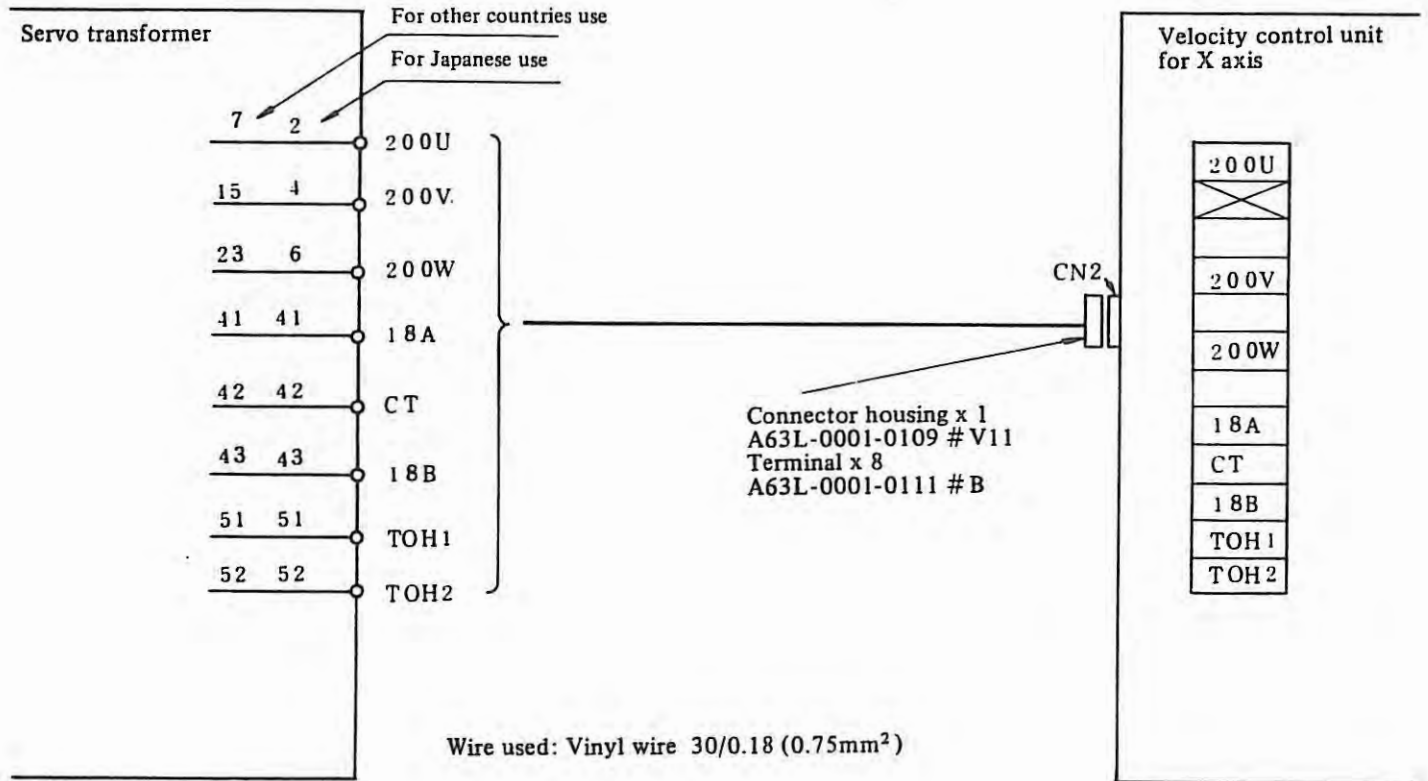
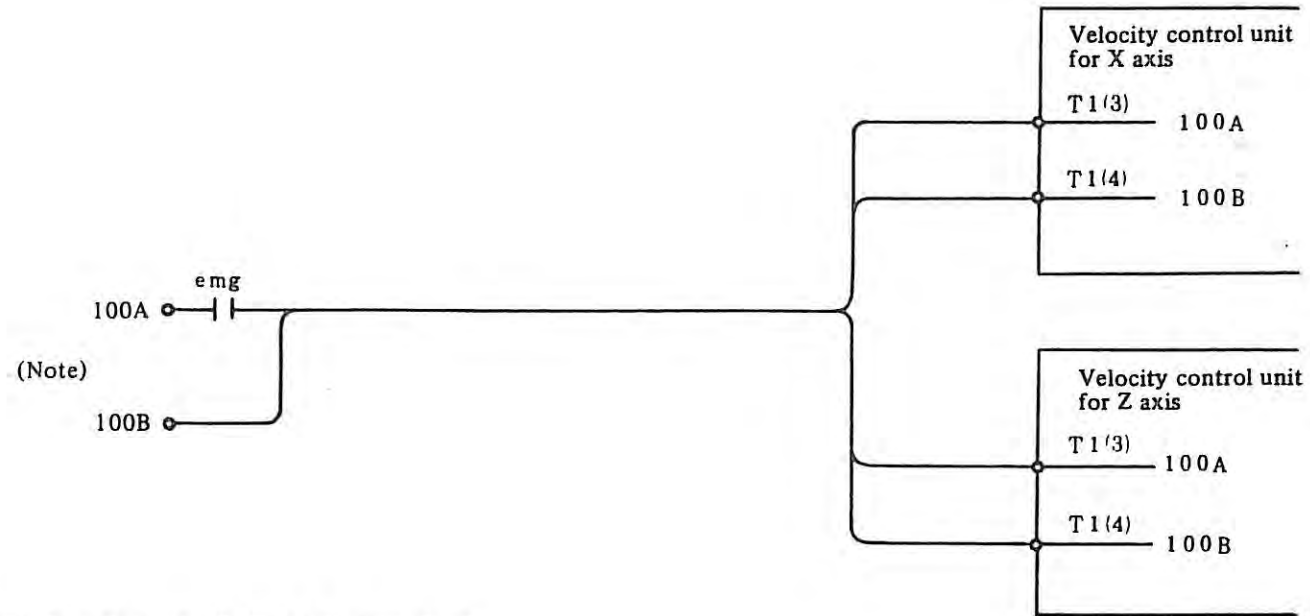

Fig. 3.9.3 (b) Connection of Cable



Terminal: Screw terminal M4 (for both control unit and velocity control unit)

Wire used: Vinyl wire 30/0.18 (0.75mm²)

(Note) AC 100V for 100A and 100B is provided by machine builder.

Fig. 3.9.3 (c) Connection of Cable

3.9.4 Position of connector and terminal velocity control unit (For Model 00M, 0M, 5M, 10M, 20M, 30M)

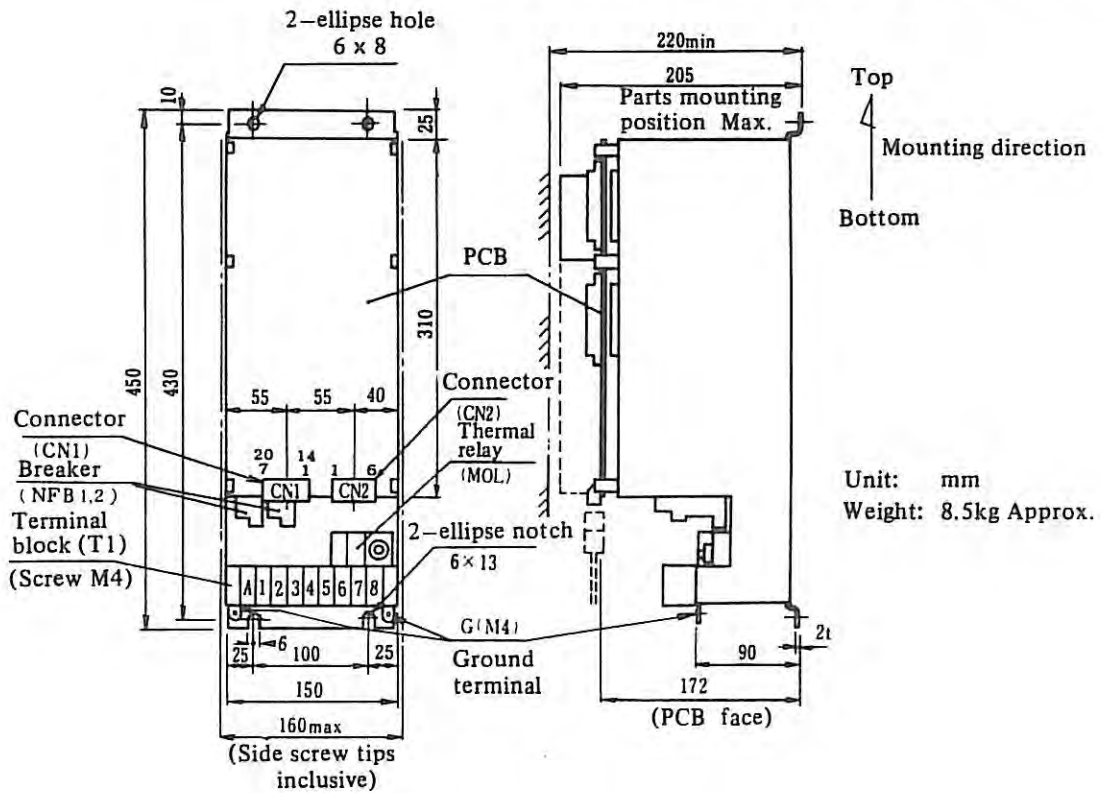

Fig. 3.9.4 (a) Velocity Control Unit without Discharge Unit

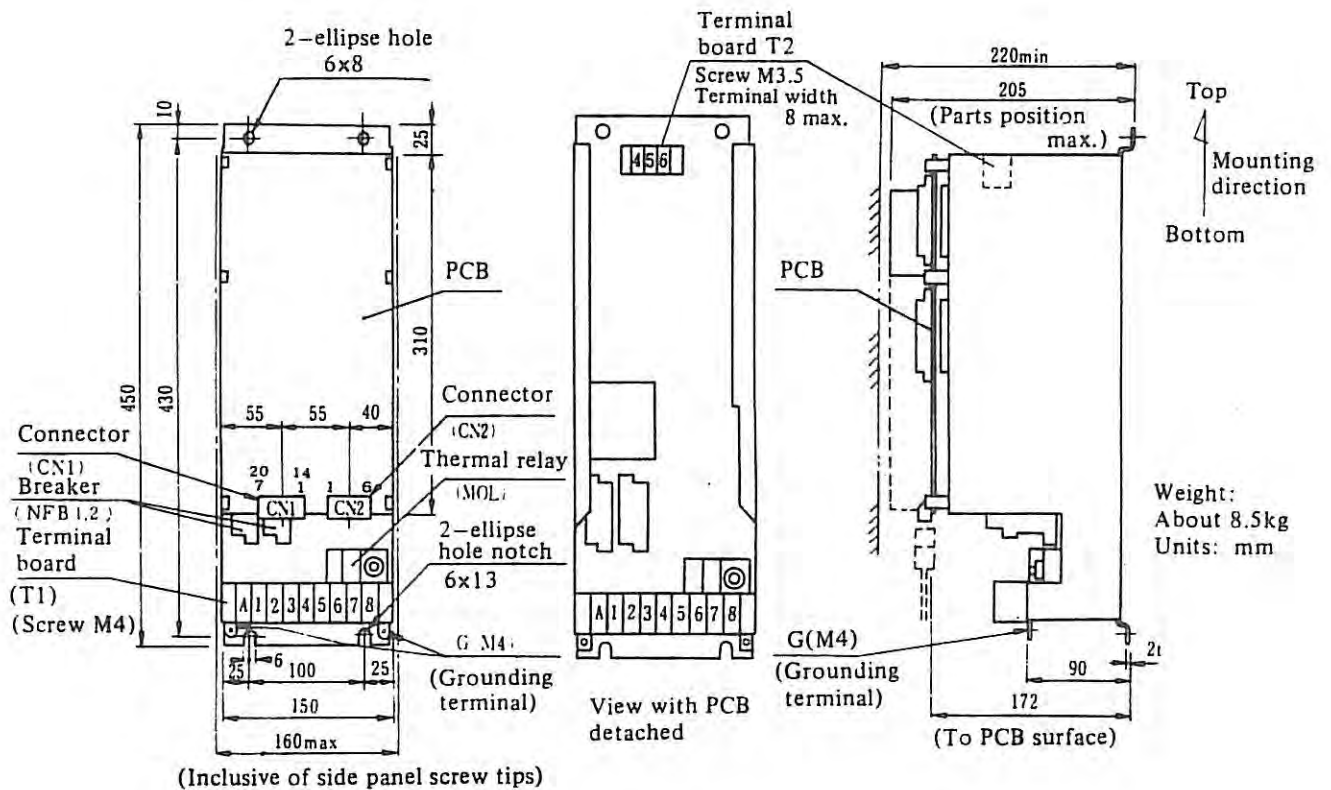

Fig. 3.9.4 (b) Velocity Control Unit with Discharge Unit

3.9.5 Details of signals (M series)

Table 3.9.5

No.	Name of signal	Signal contents	Type	Significant level	Send direction	Details
1	PRDY1 PRDY2	Velocity control unit ON signal	Contact	ON (closed)		When the contact is turned on electromagnetic contactor MCC inside the velocity control unit turns on. When it is turned off, the motor is stopped by dynamic braking.
2	ENBL1 ENBL2	Enable signal	Contact	ON (closed)		When this contact is turned on, the PWM control circuit operates. When it is turned off, no power flows to the motor.
3	OVL1 OVL2	Overload alarm signal	Contact	OFF (open)		This contact is turned off, if the thermal relay trips, or if the thermostat of the power transformer operates.
4	VRDY1 VRDY2	Velocity control unit ready signal	Contact	ON (closed)		This contact is turned on when electromagnetic contactor MCC in the velocity control unit turns on.
5	VCMD EC	Velocity command signal	Analog voltage signal	0~±12V		Motor speed is set to 1000 rpm or 2000 rpm at ±7V. Model 00M, 0M, 5M : 7V/2000 rpm Model 10M, 20M, 30M, 30MH : 7V/1000 rpm
6	TSA TSB	Velocity feedback signal	Analog voltage signal	0~±15V		3V/1000 rpm or 6V/1000 rpm

No.	Name of signal	Signal contents	Type	Significant level	Send direction		Details of contents																																
7	*ALM1 *ALM2 *ALM4 COM	Alarm interface signal	Photo-coupler signal	ON (transistor ON)	NC	Velocity control unit	<p>See 3.2</p> <table border="1"> <thead> <tr> <th></th> <th>T G L S</th> <th>O V C</th> <th>B R K</th> <th>H C L A</th> <th>H V A L</th> <th>D C A L</th> <th>L V A L</th> </tr> </thead> <tbody> <tr> <td>*ALM1</td> <td>0</td> <td>1</td> <td>0</td> <td>1</td> <td>0</td> <td>1</td> <td>0</td> </tr> <tr> <td>*ALM2</td> <td>1</td> <td>0</td> <td>0</td> <td>1</td> <td>1</td> <td>0</td> <td>0</td> </tr> <tr> <td>*ALM4</td> <td>1</td> <td>1</td> <td>1</td> <td>0</td> <td>0</td> <td>0</td> <td>0</td> </tr> </tbody> </table> <p>1 : Transistor OFF 0 : Transistor ON</p>		T G L S	O V C	B R K	H C L A	H V A L	D C A L	L V A L	*ALM1	0	1	0	1	0	1	0	*ALM2	1	0	0	1	1	0	0	*ALM4	1	1	1	0	0	0	0
	T G L S	O V C	B R K	H C L A	H V A L	D C A L	L V A L																																
*ALM1	0	1	0	1	0	1	0																																
*ALM2	1	0	0	1	1	0	0																																
*ALM4	1	1	1	0	0	0	0																																
8	100A 100B	Power supply for electro-magnetic contactor	AC voltage 1φ 100V	AC 100V	Cabinet	Velocity control unit	<p>For emergency stop, electromagnetic contactor inside the velocity control unit is turned off irrespective of PRDY1 and 2 by turning off the AC 100V, so that the motor is stopped by dynamic braking.</p>																																

3.9.6 Connections (M series velocity control unit)

Note): For details of cables K1 ~ K5, see subsection next item.

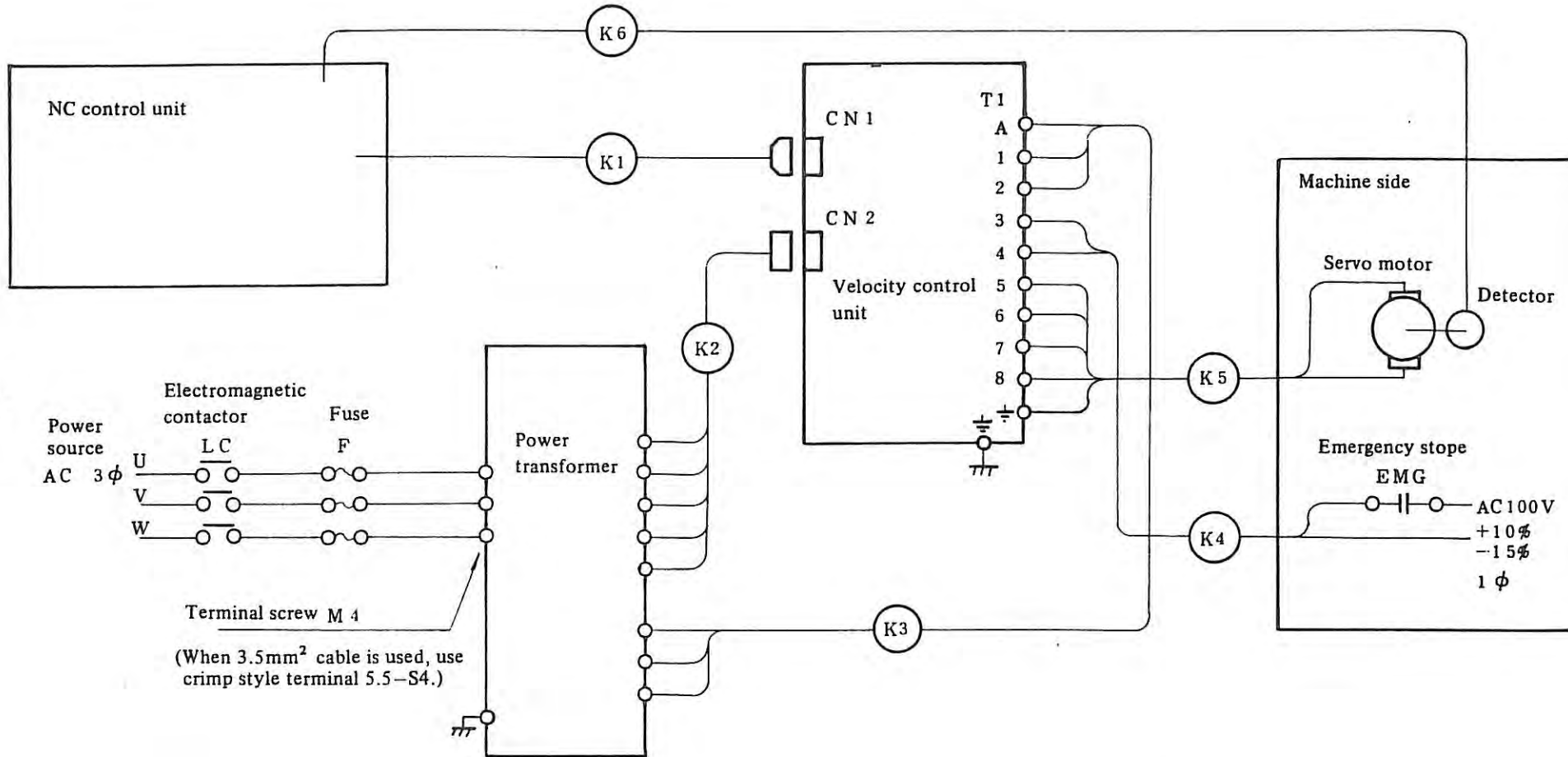

(1) Details of connections of cable K1

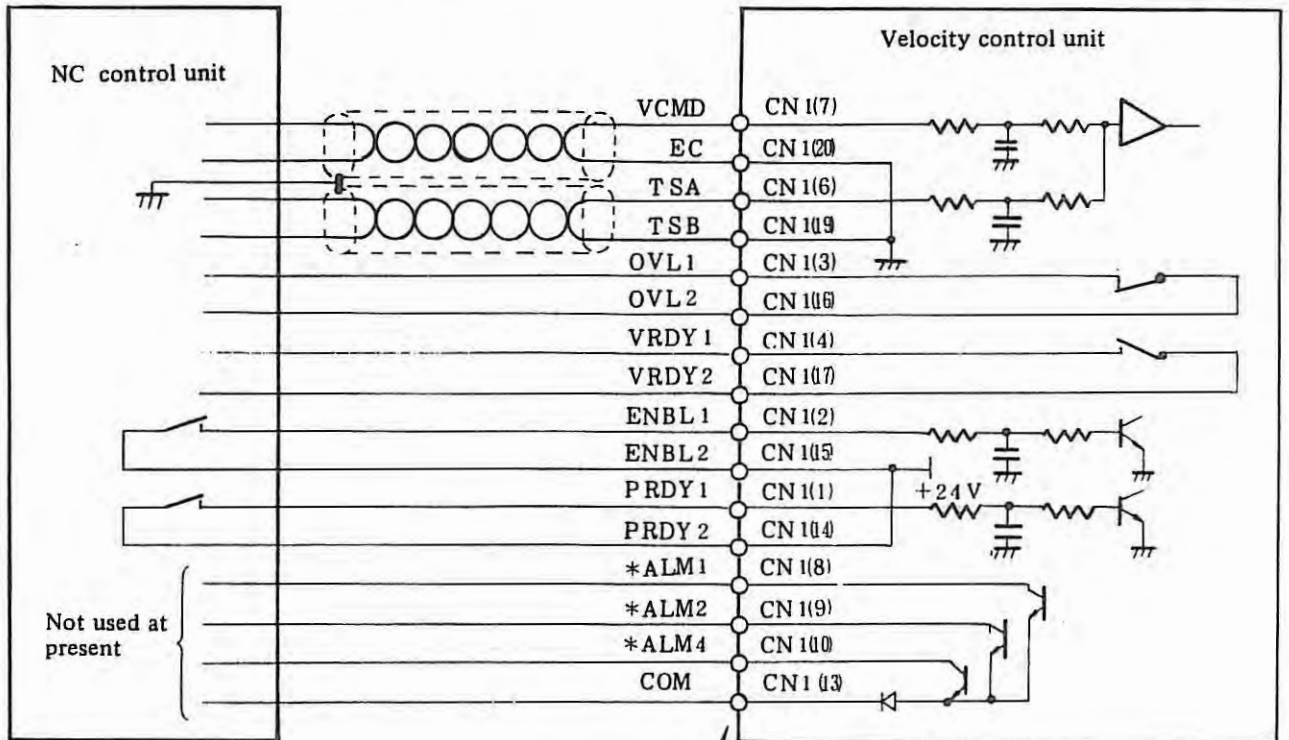

Cable employed:
 For VCMD/EC, TSA/TSB,
 0.1 ~ 0.18mm² paird
 shielded cable.
 For others; 0.18 ~ 0.3mm²
 200V vinyl wire

Connector employed MR20LFH
 (Honda Tsushin Kogyo, Co. Ltd.)

(For mounting layout of connector
 terminals, see 8.4.1.)

(2) Details of connections of cable K2

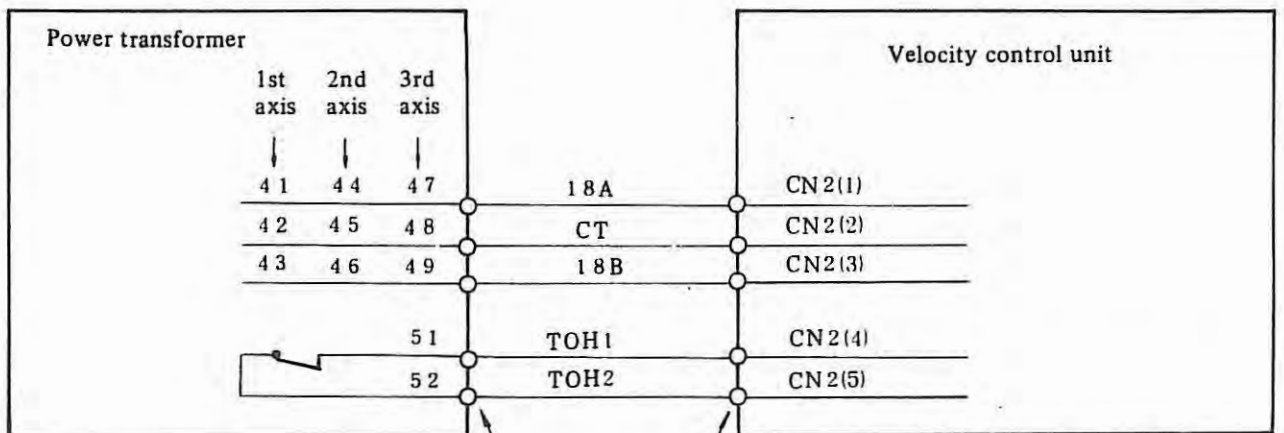

Screw terminal M4

Connector { SMS 6PW-5 } (Nippon Burndy
 employed { RC 16M-SCT3 } Co.)

(For mounting layout of connector
 terminals, see 8.4.2.)

Cable employed: 0.75mm² (30/0.18) 200V heat-resistive vinyl cable.

(3) Details of connections of cable K3

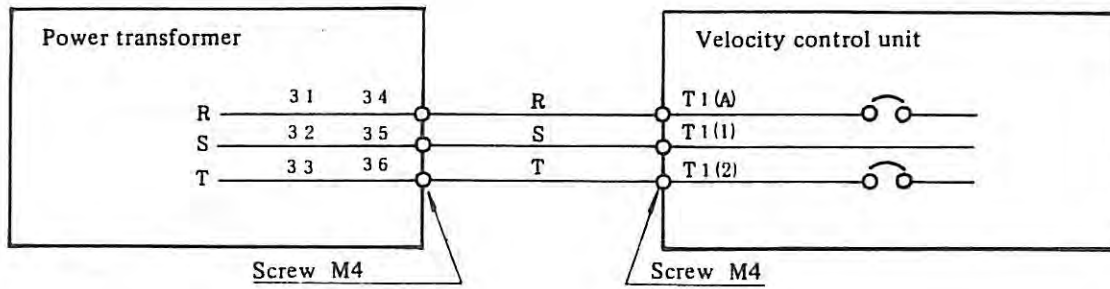

(Use crimp style terminal 5.5-S4, if 3.5mm² cable is used)

Motor employed	Cable employed
Model 00M, 0M, 5M	2.0 ~ 3.5mm ² 600V Heat-resistive vynyl cable
Model 10M, 20M, 30M, 30MH	3.5mm ² 600V Heat-resistive vynyl cable

(4) Details of connections of cable K4

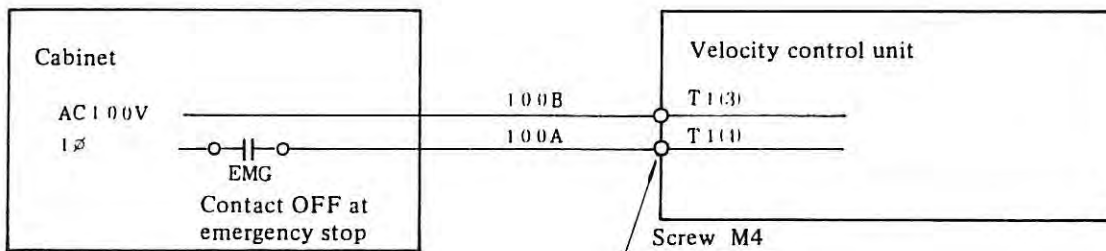

Cable material: 0.75mm² 200V vinyl cable

(5) Details of connections of cable K5

(a) For Model 00M

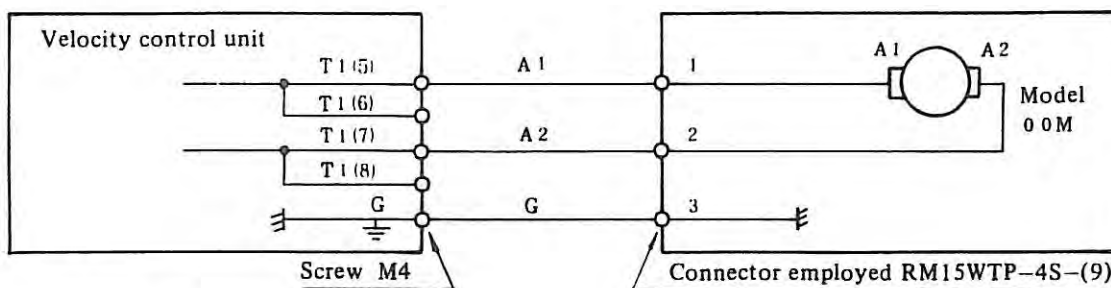

*Hirose Electric, Co.

Cable material: 3-conductor vinyl cord

(b) For Model 0M and 5M

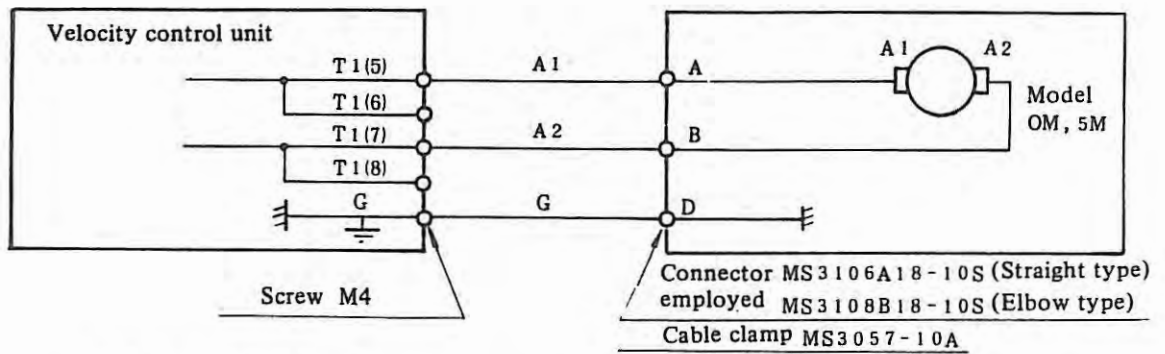

Cable material: 2.0mm²
3-conductor vinyl cabtyre cable

(c) For Model 10M, 20M, 30M, 30MH

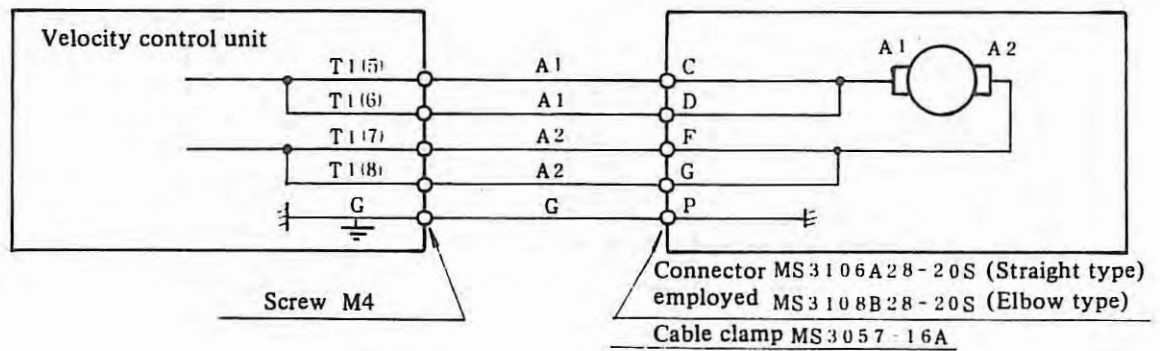

Cable material: 3.5mm²
5-conductor vinyl cabtyre cable

3.9.7 Connection

(Note): For those other than cables K2 and K7, refer to Section Item 3.9.7.

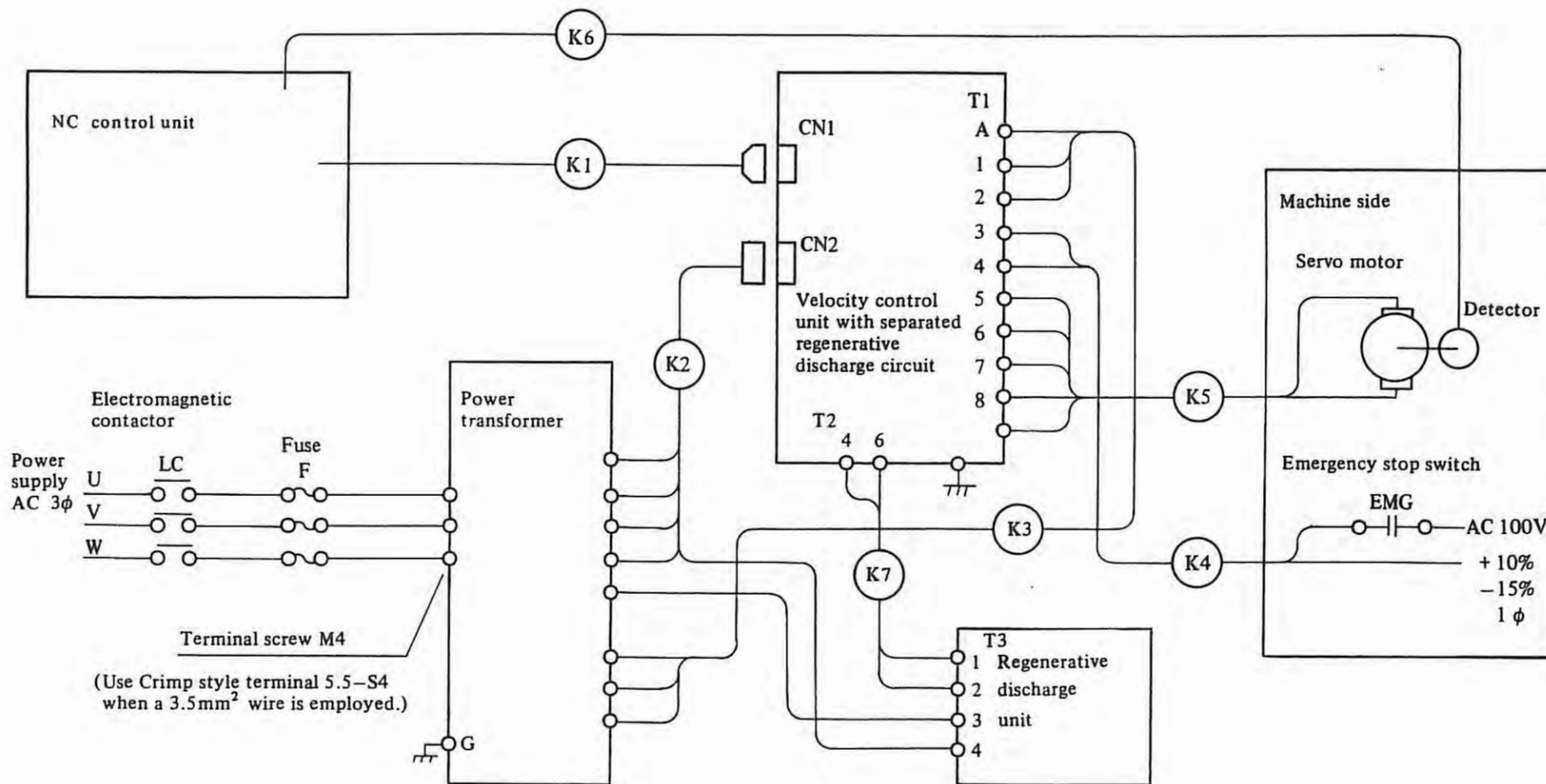

(1) Details of connections of cable K2

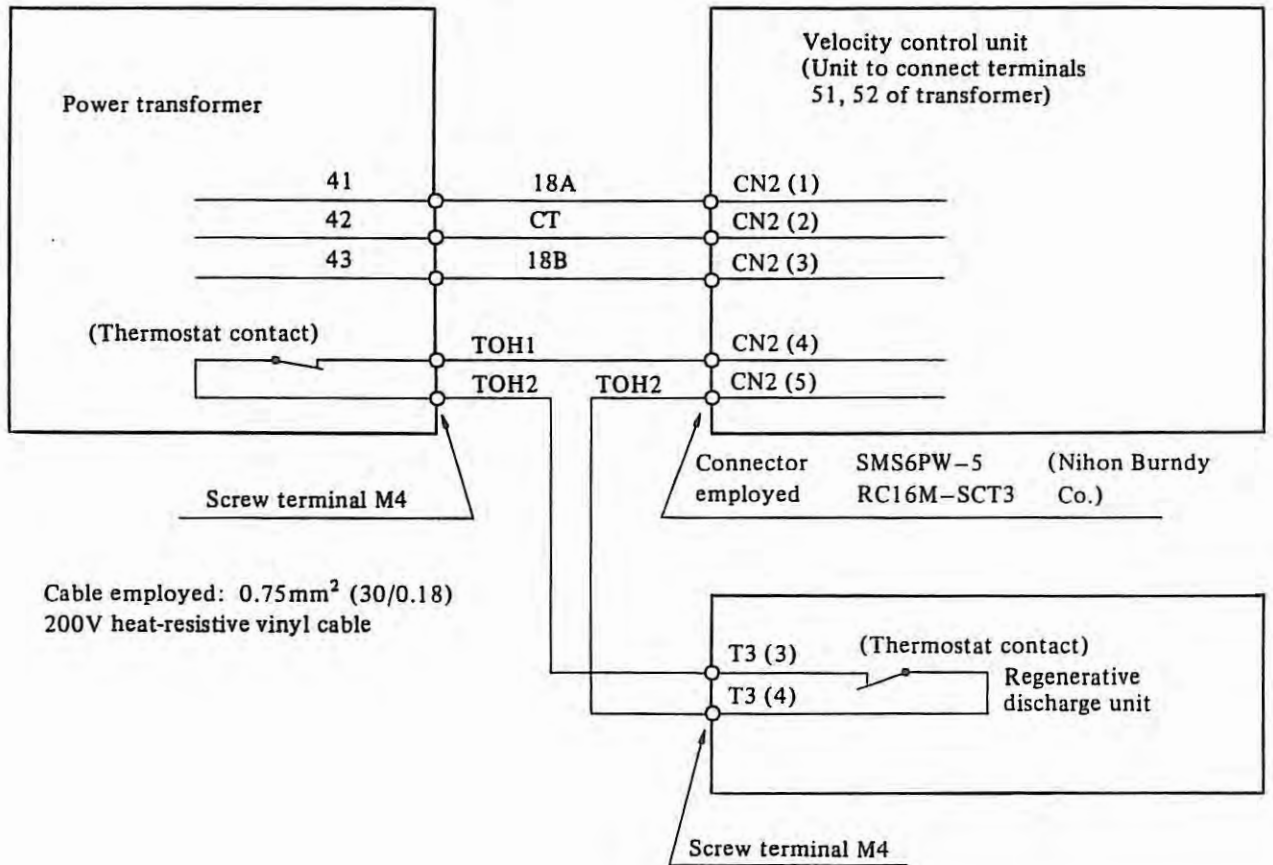

(2) Details of connections of cable K7

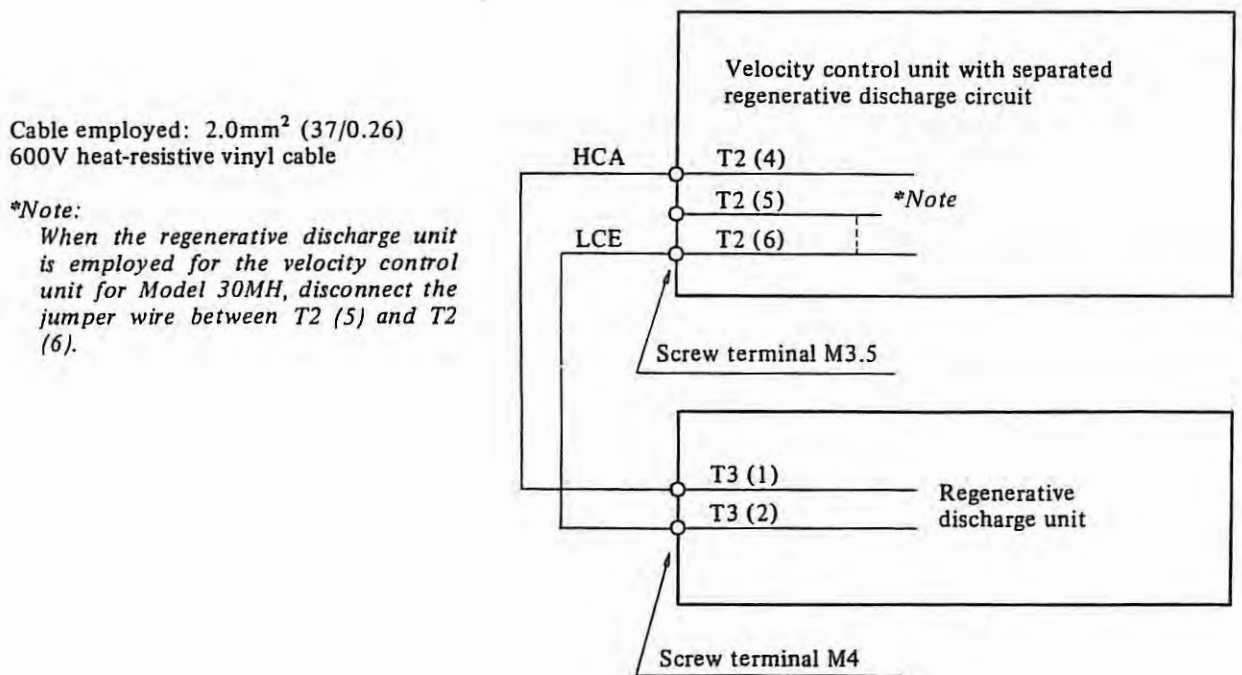

3.10 Confirmation of connection between NC and DC servo motor

For DC servo unit there are connection cables of power supply, feedback signals and motor power.

There are standard connection and reverse connection for the feedback signal cable and motor power cable according to the rotational direction which follows the feed command from the control unit.

The rotational direction corresponding to the (+) feed command

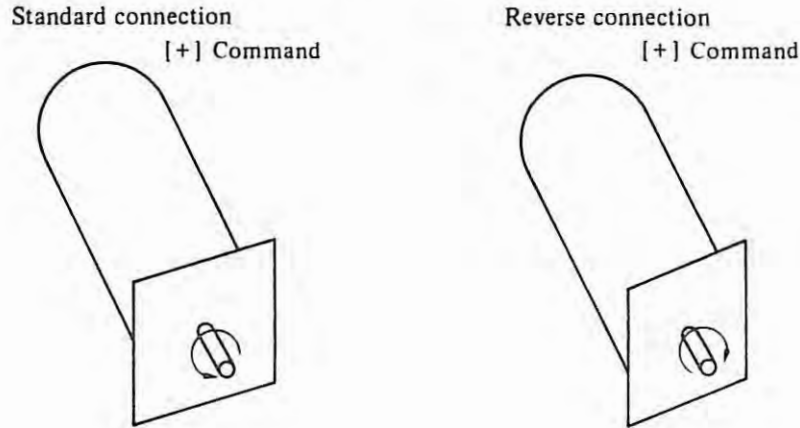

To make reverse connection, next procedure should be taken. (Refer to Appx. 2 for the details)

(1) In the case of pulse coder

- (1) Signals $PCA\alpha$ and $PCB\alpha$ should be replaced each other.
- (2) Signals $*PCA\alpha$ and $*PCB\alpha$ should be replaced each other.
- (3) Power lines A1 and A2 should be replaced each other.
- (4) Tachometer-Generator signals TSA and TSB should be replaced each other. (See Note)

(Note) This replacement shall be made only when a separate type Pulse coder (Separated from Motor) is used.

(2) In the case of resolver or inductosyn

- (1) Signals $DSA\alpha$ and $DSB\alpha$ should be replaced each other.
- (2) Signals $TSA\alpha$ and $TSB\alpha$ should be replaced each other.
- (3) Power lines A1 and A2 should be replaced each other.

(Note) α stands for X, Z.

3.11 Troubleshooting of Servo Unit

Troubles in the servo unit don't always cause an alarm depending upon cases. If an alarm appears on the CRT, observe corresponding procedures according to alarm numbers.

This paragraph summarizes troubleshooting procedures for such servo unit troubles as may not cause any alarm as major cases.

- (1) Machine tool runs away, irrespectively of the absence of commands 3.11.1
- (2) Machine tool vibrates during movement or stopping 3.11.2
- (3) Poor positioning accuracy and machining accuracy 3.11.3
- (4) Methods of confirming the operation of velocity control unit and position control unit 3.11.4
- (5) Is the fuse of velocity control unit blown out? (H series only) 3.11.5
- (6) Method of locating a defective unit in servo system 3.11.6

3.11.1 Machine tool runs away

Item	Cause of trouble	Check procedure	Countermeasures
1	Signals from position detector are abnormal.	Check wiring. Check for positive feedback.	Reconnect wiring correctly.
2	Defect between motor and position detector.	Check by DGN. See 3.7. (DGN 800 ~ 801)	Reconnect them correctly.
3	Master PCB or velocity control unit PCB is defective.		Replace defective PCB.

3.11.2 Machine tool vibrates

Item	Cause of trouble	Check procedure	Countermeasures
1	Setting failure of position control system parameters.	Check according to 5.3.	Set parameters correctly.
2	Setting failure of velocity control unit PCB.	Check PCB according to 6.2. Check PCB for special setting (special number) according to data sheet.	Set PCB correctly.
3	Fault analysis	Check if vibration cycle changes in proportion to the feedrate.	Proceed to 6, if the vibration cycle changes in proportion to the feedrate. Proceed to 4, if the vibration cycle almost remains constant, irrespectively of the feedrate.
4	Fault analysis	Check if vibrations are eliminated when velocity control unit CH5-CH6 are shorted by using a jumper wire during operation.	Proceed to 7, if vibrations are eliminated. Proceed to 5, if they are not eliminated.
5	Fault analysis	Short CH5-CH6, and check if vibrations are reduced when turning RV1 counterclockwise.	Proceed to 8, if reduced. Proceed to 9, if not reduced.

Item	Cause of trouble	Check procedure	Countermeasures
6	Machine tool, detector, or motor is defective. Interpolation accuracy is poor. Detection gain is excessively high.	Find the unit being synchronized with vibration cycle, and check it for defective parts. If interpolation accuracy is poor, the vibration cycle is once or twice per wavelength of the position detection signal. Vibrations often occur due to high detection gain in case of rotary inductosyn.	Replace or repair defective parts. Refer to the interpolation adjustment or detection gain adjustment (6.1.6).
7	Matching failure between servoamplifier setting and machine tool.	Short S9 and S11, and check if vibrations are reduced.	Change PCB setting. Contact FANUC service center.
8	Same as described above.	Check if vibration cycle ranges from several ten Hz to several hundred Hz.	Change PCB setting. Contact FANUC service center.
9	Velocity control unit PCB is defective.	Check the waveform at each part of velocity control unit PCB, or replace PCB.	Replace PCB.

3.11.3 Poor positioning accuracy or machining accuracy

(1) Overshoot

Item	Cause of trouble	Check procedure	Countermeasures
1	Short acceleration/ deceleration time.	Check if motor current is saturated.	Set the acceleration/ deceleration time longer.
2	Low rigidity or play at coupling flanges between motor and machine tool.	Check if this failure can be improved by decreasing the position loop gain.	Reduce the position loop gain. Improve the rigidity and play of machine tool.

(2) Poor 1-pulse feed accuracy

Item	Cause of trouble	Check procedure	Countermeasures
1	Fault analysis	Check if the positioning is correct at the detector position by DGN800 ~ 801.	Proceed to 2, if correct. Proceed to 3, if not correct.
2	Deflection, stick slip, or play in machine tool system.	Measure the positioning accuracy at each part of machine tool and motor shaft.	Adjust the machine tool.
3	Low gain of servo system.	Check if this poor accuracy is improved by turning RV1 in velocity control unit PCB clockwise by 2 ~ 3 divisions.	Readjust RV1. Contact FANUC service center.

(3) Poor positioning accuracy to correct commands

Item.	Cause of trouble	Check procedure	Countermeasures
1	Fault analysis	Check if positioning is correct at the detector position by DGN800 ~ 801.	Proceed to 2, if correct. Proceed to 3, if not correct.
2	Deflection, stick slip, or play of machine tool system.	Measure the positioning accuracy at each part of machine tool and motor shaft.	Adjust the machine tool.
3	Position control unit is defective.	Replace PCB (Master PCB, etc.) containing the position control unit.	Replace defective PCB.
4	Position detector is defective.		Replace defective unit.
5	Velocity control unit PCB is defective.		Replace defective unit.

(4) Poor roundness of circle by 2-axis feed

Item	Cause of trouble	Check procedure	Countermeasures
1	Fault analysis	Measure the roundness and check if circle is distorted in the axial direction, or if it is deformed to be an ellipse in 45° direction.	Proceed to 2, if distorted axially. Proceed to 3 and 4, if deformed in 45° direction.
2	Fault analysis Poor positioning accuracy.	Unevenness at a change of quadrants. Measure positioning accuracy of each axis.	Proceed to 5 and 6. Adjust the machine tool about poor accuracy axis.
3	Maladjustment of position loop gain.	Perform simultaneous 2-axis 45° feed, and adjust RV4 of velocity control unit PCB so that the difference of the position deviation amounts is within ±1% between axes by DGN800 ~ 803.	Adjust position loop gain to eliminate gain difference between axes (See Note 1.)
4	Detection gain differs every axis.	A circle is deformed to be an ellipse in 45° direction even after adjustment in item No. 3.	Adjust the detection gain (6.1.6).
5	Adjustment failure of Fmin of inductosyn or resolver interface PCB.	Check Fmin adjustment.	Readjust Fmin. See 6.1.6.
6	Improper backlash or backlash compensation amount.	Try changing the backlash compensation amount.	Adjust backlash or change backlash compensation amount.

(Note) The position gain when X, Y, Z and 4th axes are moved in same direction by F4 digits feed from MDI operation can be obtained by calculation as below.

$$G = \frac{16.7F}{E}$$

F : Feed rate [mm/min], [0.1 inch/min], [degree/min]
 E : Position deviation [0.001 mm], [0.0001 inch] [0.001 degree]
 G : Position gain [sec⁻¹] (standard: 30 sec⁻¹)

And then check the servo position deviation from DGN 800, 801. Adjust the position deviation with in $\pm 10\%$ of the target value by F/V converter voltage compensation adjustment variable resistor (RV4) in velocity control unit. However, difference between axes must be within $\pm 1\%$.

45° directional elipes can be adjusted by this method but X axis or Y axis directional elipes can't adjusted by this method.

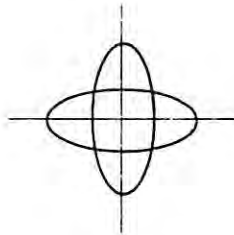

No adjustable

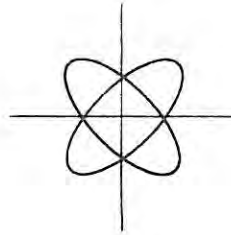

Adjustable

3.11.4 Method of confirming the operation of velocity control unit and position control unit

The servo system can roughly be divided into the position control unit, velocity control unit, DC motor, and detector.

Since these component units compose a closed loop, the entire servo system becomes defective, if one of these component units is in trouble, and it is sometimes difficult to identify the defective unit from others.

In such a case, check the operating conditions of the position control unit and velocity control unit by the following procedures.

1) Position control unit operation check

- (a) Disconnect the power cable from the DC motor.
- (b) Set a large value to parameter No. 074, 075.
- (c) After turning on NC, apply pulses by handle, and check the output voltage of VCMD output signal of master PCB.
- (d) Turn the motor shaft slightly by a certain method, and check the VCMD signal of master PCB.

(Note) If NC is turned on after disconnecting power cable from the DC motor, the table powers in case of the gravity axis. Insert suitable lumber or the like.

Decision

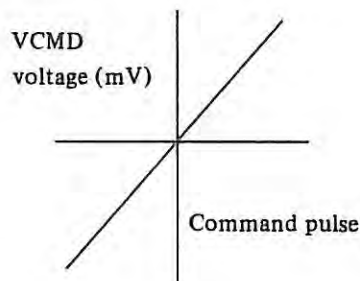

When a positive (+) pulse is applied from the handle, VCMD voltage should continuously changes from - voltage + voltage.

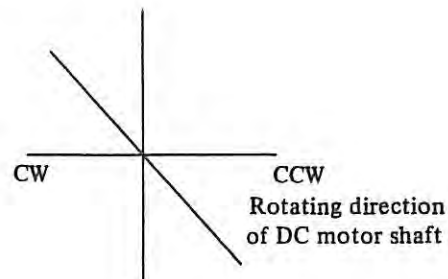

When turning the motor shaft counter-clockwise, the VCMD voltage should continuously change from + voltage to - voltage.

3.11.5 Velocity control unit fuses blow out (H series)

In addition to a malfunction of velocity control unit or DC servo motor, there are following causes of blowing out of fuses.

- (i) Malfunction of machine tool
- (ii) Incorrect cutting condition
- (iii) Incorrect setting of feedrate or acceleration/deceleration time constant.
- (iv) Malfunction of position control circuit
- (v) Incorrect cable wiring

When fuses blow out, the machine should be operated after investigating the causes and removing them.

(1) Location and role of fuses

Fig. 3.11.1 shows the connections on DC servo motor power cables. The velocity control unit fuses are located on secondary side of transformer and in front of thyrister bridge.

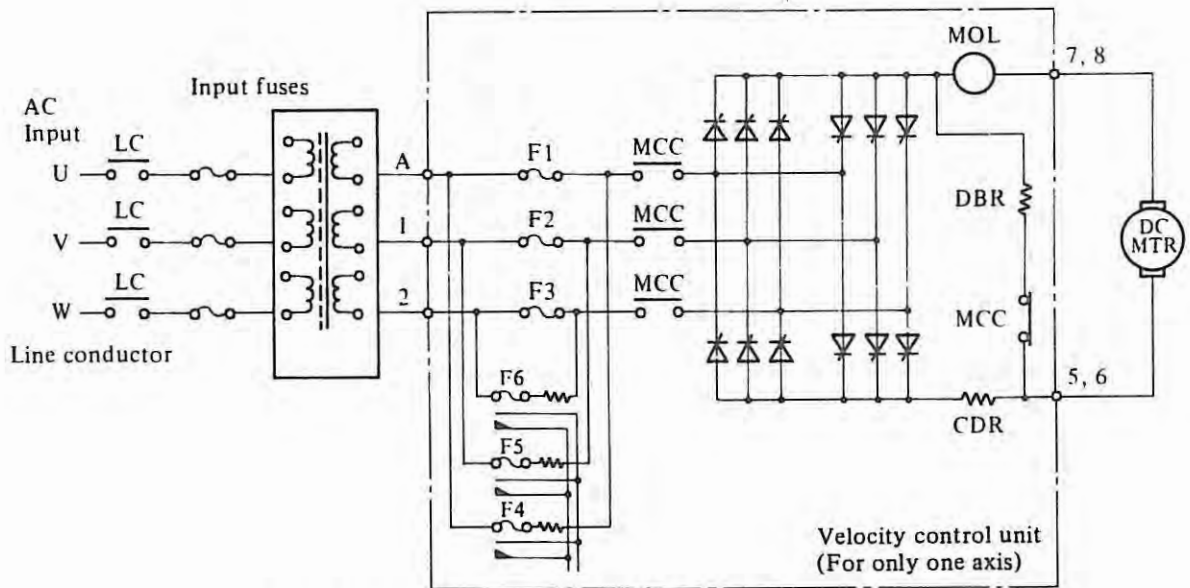

Fig. 3.11.1 Connection on DC Servo Motor Power Line

Purpose of each fuse

Fuse	Purpose	Remark
F1 ~ F3	Protection of thyrister from over-current	Fuses which blow out by the current smaller than the current which destroys thyristers are used.
	Protection of motor from overcurrent.	Protection of motor from overcurrent in a short time.
F4 ~ F6	Alarm signal generation for blow out of fuses F1, F2 and F3.	

The fuses on primary side of transformer will not blow out easily except for faulty transformer, short-circuit around primary and/or secondary side of transformer, because:

- (a) Capacity of these fuses is larger than that in velocity control unit and usually
- (b) the current on primary side is usually smaller than that on secondary side because of secondary voltage being larger than primary voltage.

(2) Causes of blowing out of fuses

The velocity control unit fuses may blow out by means of various reasons.

Table 3.11.1 shows the principal reasons.

Table 3.11.1

Item	Classification	Principal reasons	Remark
1	Malfunction of machine tool	(1) There is an abnormally big friction on the sliding surface. (2) Incorrect engaging of gear train. (3) The movable member of machine collides with the work. (4) The mechanical clamp is being effected.	a. Measure the current over all movable stroke. b. Check whether the current changes largely for each revolution of motor.
2	Incorrect cutting condition	(1) Overcurrent by too deep cutting. (2) Heavy cutting exceeding the rating continues.	The temperature of the motor will rise highly if heavy cutting continues.
3	Malfunction of position control circuit	(1) A large current flows at power on because of the wrong setting of drift compensation amount.	
4	Miconnection of wiring	(1) Oscillation by positive feedback.	Immediately after cabling only.
5	Malfunction of motor	(1) Oscillation by the malfunction of feedback device. (2) Overcurrent caused by demagnetization.	
6	Wrong setting in velocity control unit	(1) Wrong setting. (2) Too high gain.	
7	Malfunction of velocity control unit		

(3) Trouble shooting and remedy when fuse blows

① Trouble shooting of trouble occurrence state

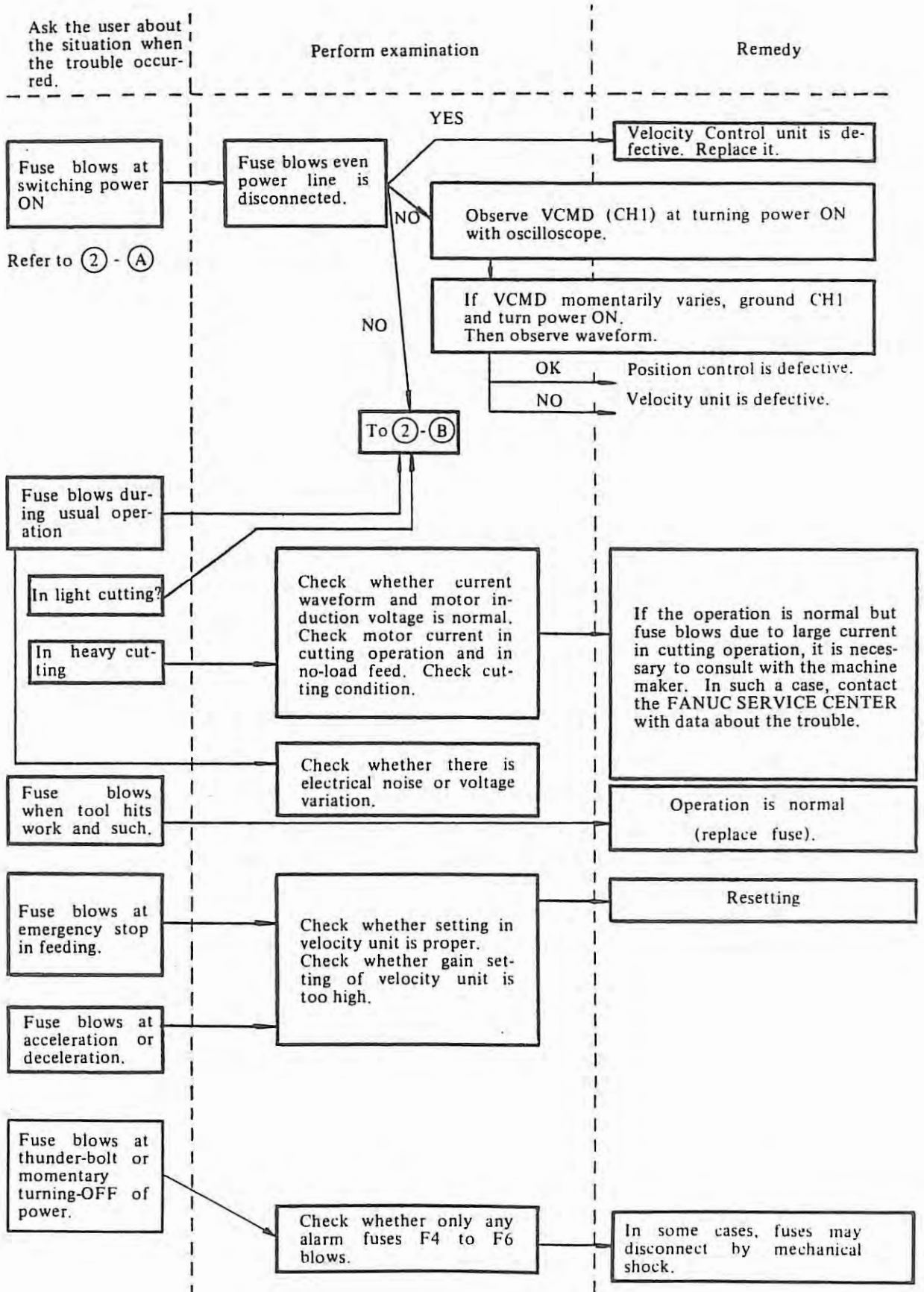

② In the case where fuse blows in the device which is normally operating.

In this case, misconnection and improper setting may be scarce, but note that there may be a failure due to poor contact.

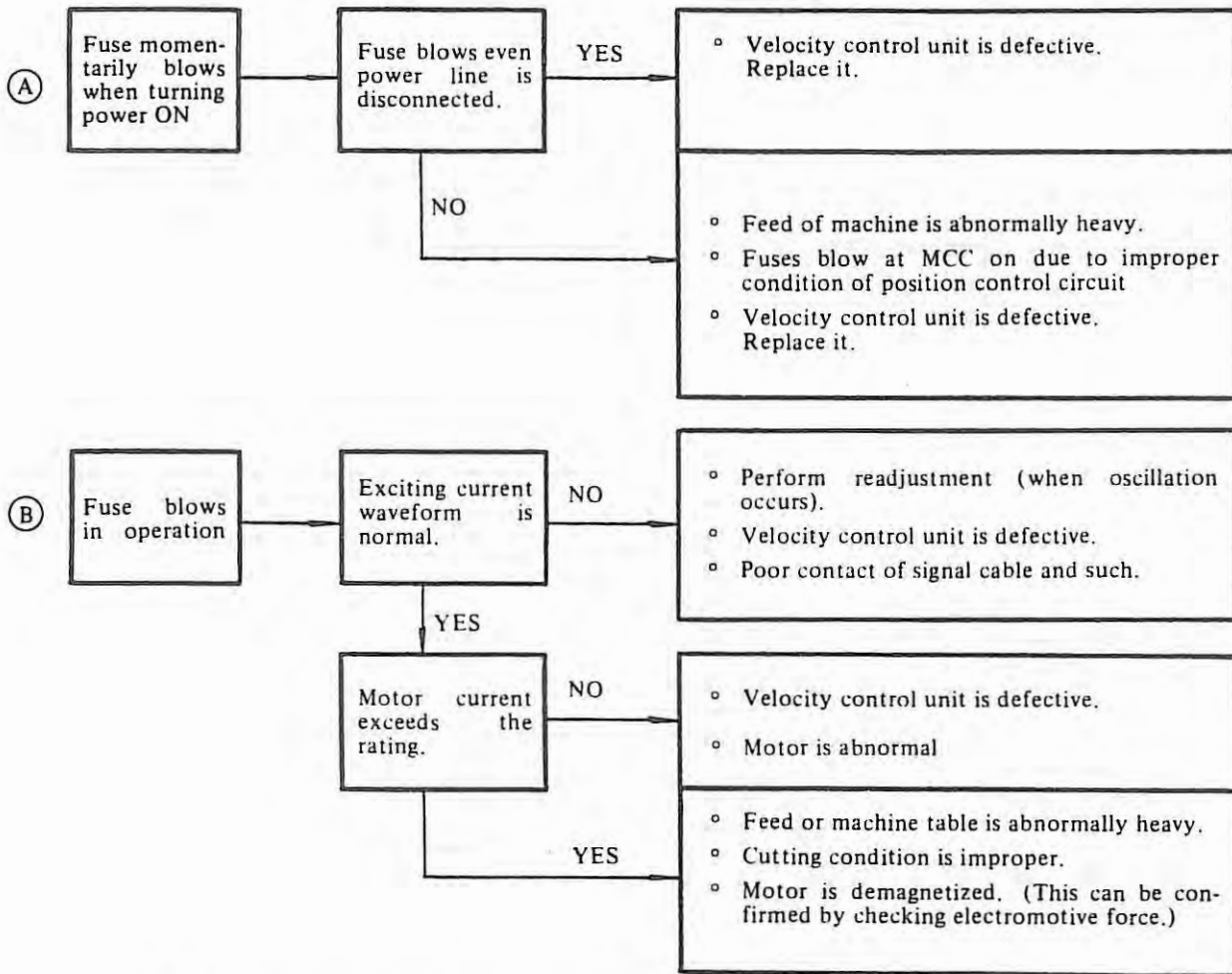

The following two disposals are required if fuses blow during operation.

(i) Measure the motor current (measures for each feedrate)

If the current exceeds the rating of the motor, overload or failure of the motor is considered.

(ii) Observe the waveform (to see whether the velocity control unit is normal or not.)

Is the waveform normal?

Does the oscillation occur when fuses are likely to blow?

When the waveforms for oscillation are observed, lower the velocity loop gain (RV1) or confirm the position loop gain.

(iii) Checking the demagnetization

Measure: motor speed N (RPM)
 terminal voltage V_{DC} (V)
 current I_{DC} (A)
 during rapid traverse.

If the value:

$$V = V_{DC} - I_{DC} \times R_m \text{ (V)}$$

is smaller than:

$$K_e \times N \text{ (V)}$$

the motor is got demagnetized, where R_m and K_e are coefficient of motor as follows.

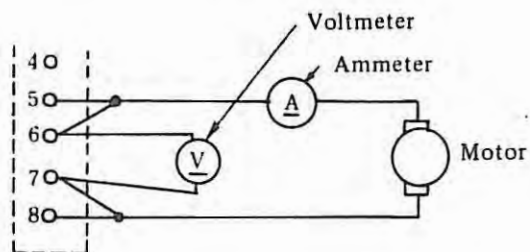

Type of motor	Rm $\pm 10\%$	Ke $\pm 10\%$
Model 0	0.50 Ω	25V/1000 RPM
Model 5	0.68 Ω	50V/1000 RPM
Model 10	0.28 Ω	56.6V/1000 RPM
Model 20	0.25 Ω	79.5V/1000 RPM
Model 30	0.32 Ω	120V/1000 RPM

③ Blow out of fuse in the process of installation

The following items must be checked prior to perform the method ①.

- (i) Check the input power voltage and transformer tap.
- (ii) Check the phase rotation of power supply.
- (iii) Check the setting of power frequency.
- (iv) Check the polarity of motor power cable and feedback cable.
- (v) Check the adjustment of dither and gain on the Velocity control unit.

Location of fuses

View from rear door (For models 0 and 5)

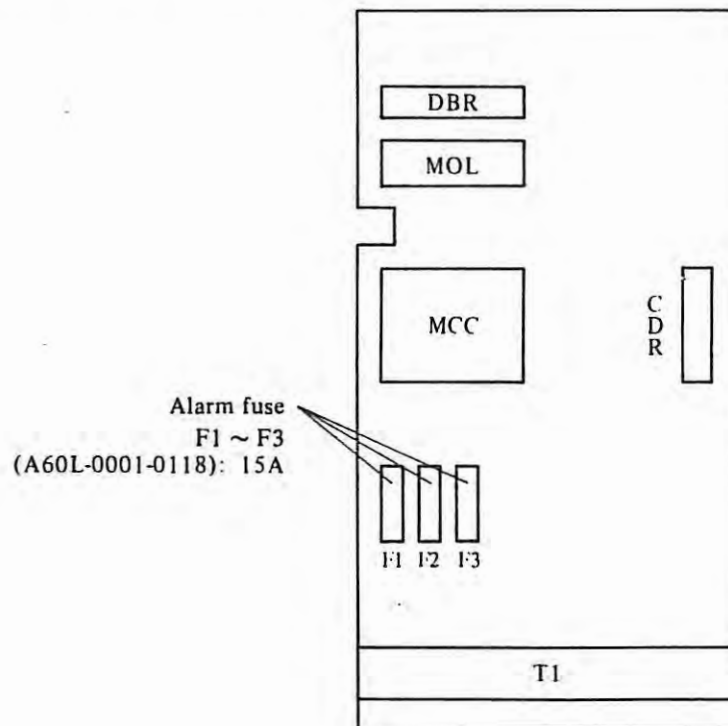

View from rear door (For models 10, 20, 30, 10H, 20H and 30H)

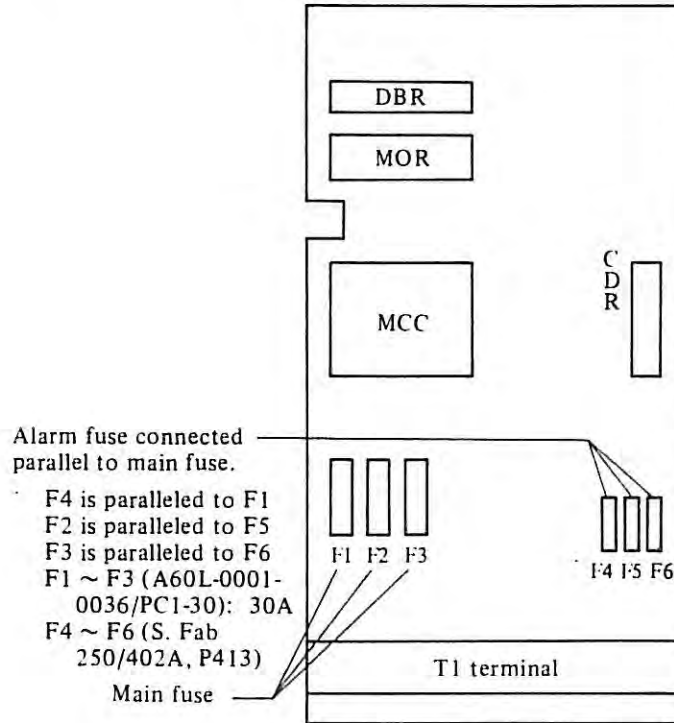

View from front door (For model 0, 5, 10, 20, 30, 10H, 20H and 30H)

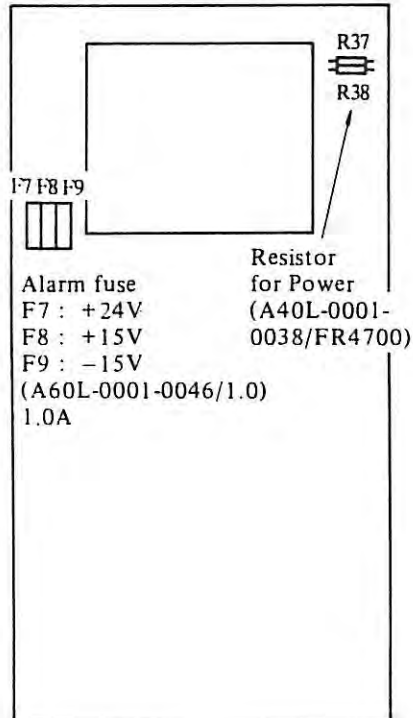

3.11.6 Checking of servo system

Procedure

- (1) Connect the CH5 and CH6 on the velocity control unit PCB.
- (2) Disconnect the motor power cables and connect a resistor of 5 to 10Ω (150W) as shown in the figure below.

Note 1. If the P.C.B. number A20B-0007-0360, 1, open a short bar S20 also.

- (3) Set a large amount to parameter No. 074 to 075.
- (4) Turn on the NC power and operate manually to put some pulses observing the waveform across the resistor.

Note: If the power of NC is turned on after removing the power cables of the DC motor, the work table will slide down along the gravity axis. So insert a wooden bar, etc. to prevent from sliding down, if there is a gravity axis.

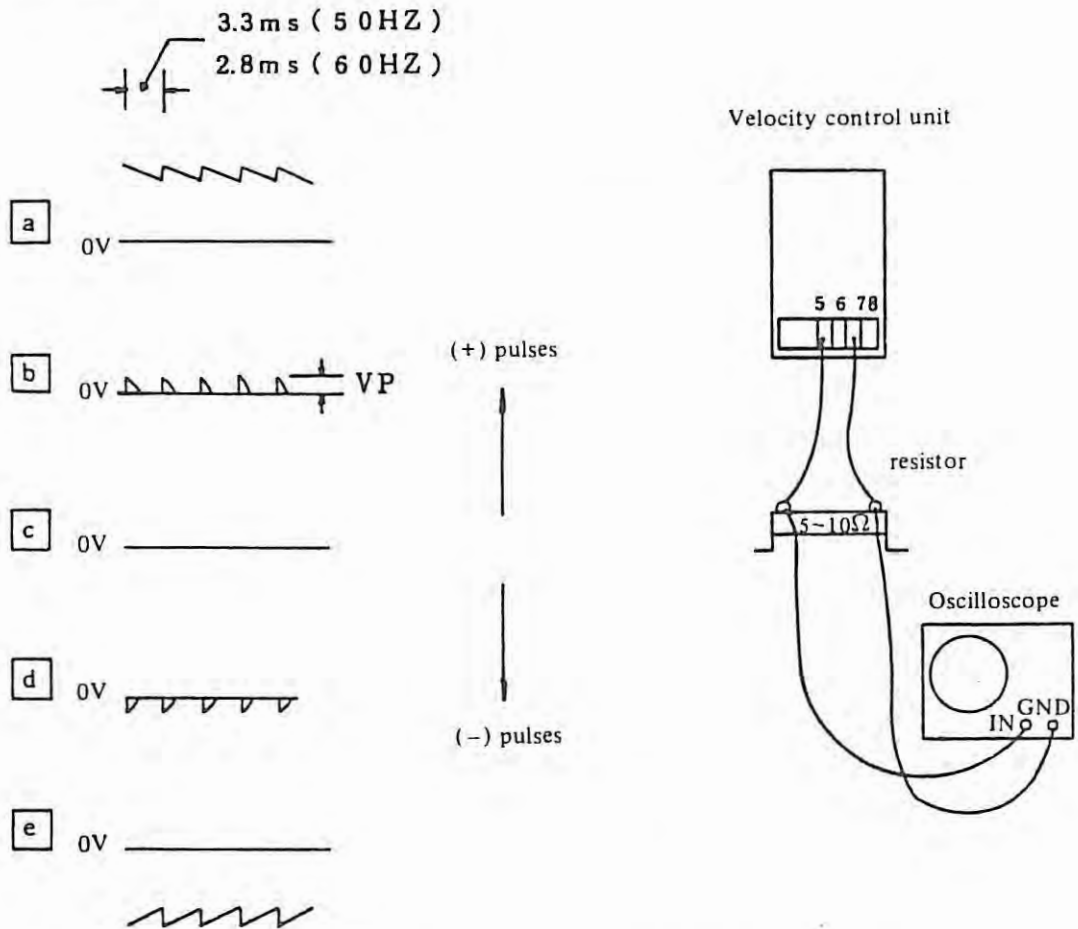

- (1) The wave shape, when power is put on, must be one of [b], [c] or [d].
- (2) In [b] and [d], the period must be 3.3 ms (2.8 ms) when V_p is higher than 20 volts and if V_p is lower than 20 volts, the period could be different and the velocity control unit is considered to be normal.
- (3) Changing from [b] to [d], or [d] to [b] must be obtained by move command less than 0.005 inch (or 0.05 mm) by manual operation.
- (4) The waveform must be changed continuously in the order [c] to [b] to [a] or [c] to [d] to [e] according to the increase of command values by manual operation.

Troubles and Causes

Values in parentheses are for 60Hz.

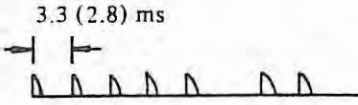
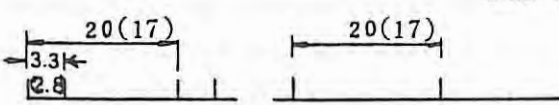
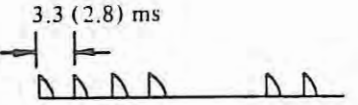
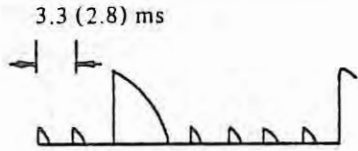
Trouble	Cause
 <p>Defect of one wave per 6.</p>	<p style="text-align: right;">Unit: ms</p>  <p>Fig. 1 shows normal Thyristor gate signal. Fig. 2 shows defect of one pulse, which results the wave shown left.</p>
 <p>Defect of 2 waves per 6.</p>	<p>There is no gate signal at all on one Thyristor per 6.</p>
 <p>Irregular wave.</p>	<p>The phase rotation of power input is not correct. Velocity control unit is affected by noise generated in it.</p>

ii) Method of checking out for the Position Control Circuit

- (1) Remove the motor power cables.
- (2) Set large value to parameter 074 ~ 075.
- (3) Turn on NC and give the move command by manual operation then check the voltage of VCMD output from master PCB.
- (4) Rotate the shaft of motor by some means and check the voltage of VCMD.

Note: If the power of NC is turned on after removing the power cable of the DC motor, the work table will slide down along the gravity axis. So insert a wooden bar, etc. to prevent from sliding down if there is a gravity axis.

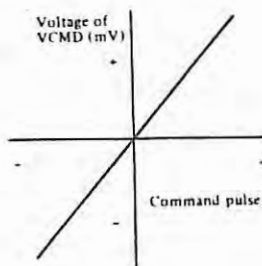

When a plus move command is given by the manual operation, the voltage of VCMD must change continuously from negative to positive.

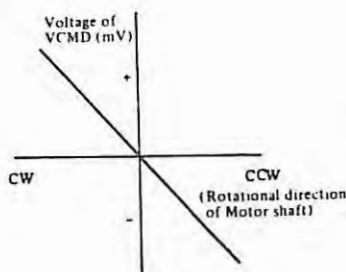

When motor shaft is rotated in CCW, the voltage of VCMD must change continuously from positive to negative.

4. ADJUSTMENT

4.1 Procedure of adjustment

This section shows adjustment on setting. The machine adjust the these item according to check item in this section.

No.	Contents	Remarks
1	Check external view of control unit and servo unit.	Refer to Item 4.1 (1)
2	Check being perfect the connection of screw terminals.	Refer to Item 4.1 (2)
3	External cables connection	Refer to Item 4.1 (3)
4	As setting electrical power source for NC "OFF", connect the power input cable.	Refer to Item 4.1 (4)
5	Check the insertion position of connector and PCB.	Refer to Item 4.1 (5)
6	Confirmation for setting <ul style="list-style-type: none"> • Tap set of transformer • Setting on velocity control unit PCB • Setting on control section PCB 	Refer to Item 4.1 (6)
7	Confirmation for input power source voltage, frequency and phase rotation.	Refer to Item 4.1 (7)
8	Confirmation is made for that output voltage is not shorted with ground.	Refer to Item 4.1 (8)
9	Power on and check output voltage	Refer to Item 4.1 (9)
10	Adjustment of velocity control unit	Refer to Item 4.1 (10)
11	Adjustment of photo Amp. output wave form of tape reader	Refer to Item 4.1 (11)
12	Confirm interface with NC and machine side	Refer to Item 4.1 (12)
13	Setting and confirmation should be made for each parameter and setting data.	Refer to Item 4.1 (13)
14	Power off	Refer to Item 4.1 (14)
15	Connect motor drive line	Refer to Item 4.1 (15)
16	Power on	Refer to Item 4.1 (16)
17	Check movement of each axis by manual feed	Refer to Item 4.1 (17)
18	Adjustment for servo system	Refer to Item 4.1 (18)
19	Confirm that all functions of NC are able to normally operate or not.	Refer to Item 4.1 (19)

(1) Check external view of control unit and servo-unit

Items
Check dirt and damage on external view of MDI/CRT unit, internal position display unit and internal manual operation board etc.
Check loosening fixture or being detached of PCB, tape reader unit and velocity control unit etc. within locker.
Check damage on cables and conduits etc. (Cover strippings etc.)

(2) Check being perfect the connection of screw terminals

Item
Terminal plate of input unit TP1 (U, V, W)
Terminal plate of input unit TP2 (EON, EOF, COM, FA, FB)
Terminal plate of input unit TP3 (200A, B)
Terminal plate of input unit TP4 (U1, V1, EMGIN 1, 2, EMGOUT1, 2)
Terminal block of power unit +5 V
Terminal block of power unit 0V
Terminal block of power unit +24 V
Power ON/OFF button of MDI & CRT unit
Terminal block of tape reader unit
Input transformer terminal block for export. (Primary and secondary side)
Power transformer terminal block for servo of first set. (Primary side, secondary side 100A, B TOH1, 2)
Power transformer terminal block for servo of second set. (Primary side, secondary side 100A, B TOH1, 2)
For the position where cover is made for an each terminal base, confirmation is required for being covered or not.

(3) External cables connection

In regard to following articles, confirmation should be made for every one set at the time of its installation.

Item
After striping cable external cover, check for that the cable is connected to the earth plate by cramp metal or not.
If the external MDI & CRT is provided, check for that the terminal connector of serial transfer bus is fixed or not.
Check for that the enough large (more than 14 mm ²) protection earth cable is connected or not between NC and machine side magnetics cabinet.
Check for that the protection earth is being one point earth type or not as connecting from the machine side magnetics cabinet to the grounding earth.

In regard to following items, confirmation should be only made for the initial equipment and new maker.

Item
Check for that all signal cables are made into one shield or not.
Cable specifications are as being designated by FANUC or not. (for DC motor signal).

Item
Cable specifications are as being designated by FANUC or not. (for DC motor drive).
Cable specifications are as being designated by FANUC or not (for velocity control unit interface).
Cable specifications are as being designated by FANUC or not (for position coder).
Cable specifications are as being designated by FANUC or not (for spindle analogue output).
Cable specifications are as being designated by FANUC or not (for manual pulse generator).
Cable specifications are as being designated by FANUC or not (for external position display).
Cable specifications are as being designated by FANUC or not (for external MDI & CRT).
Cable specifications are as being designated by FANUC or not (for tape puncher).
Cable specifications are as being designated by FANUC or not (for RS232C interface).

(4) As setting electrical power source for NC "OFF", connect the power input cable.

Item
Motor power cables are left as being disconnected.
S20 on X axis velocity control unit P.C.B. (A20B-0007-0360) is set open. S23 on X axis velocity control P.C.B. (A20B-0009-0320) is set short.

(5) Check the insertion position of connector and PCB.

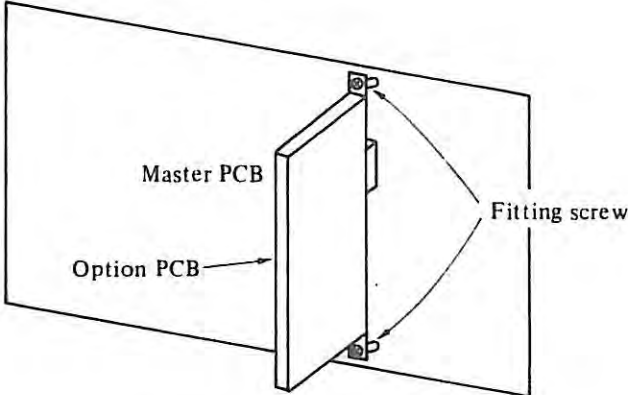
Items
Are cramp screws for HONDA connector firmly tightened?
Are nail type fixtures fitted with flat cable connector?
Are nail type fixtures fitted with brown connector for power source?
Are screws not loosened for option print plate fixture?

Are ROMs exactly mounted with IC socket on ROM card.
Are ROMs exactly mounted with IC socket on PCB for FANUC PC-MODEL B.

(6) Confirmation for setting

In regard to Items from (a) to (d), set is made with every one unit at the time of setting.

(a) Tap set of transformer (See Item 4.2)

Items
Tap setting of servo power transformer.
Tap setting of tape reader power transformer (AC 200/220V) (For only tape reader with reel)
Tap setting of input transformer for export.

- (b) Setting on control section PCB. (Refer to Item 6.1)
- (c) Setting on velocity control PCB. (Refer to Item 6.2)
- (d) Setting on DC spindle servo unit control PCB. (Refer to Item 6.3)
- (e) Setting on AC spindle servo unit control PCB. (Refer to Item 6.4)

(7) Confirmation for input power source voltage, frequency and phase rotation

Items
In case of common use for power source of control unit and servo unit, confirm the input is applied as following or not. AC 200/220V $\begin{matrix} +10\% \\ -15\% \end{matrix}$, 50/60Hz ± 1 Hz, 3 ϕ (However, combination with 220V and 50Hz is disapproved.)
Power source input for control unit only is applied as followings or not. AC 200/220V $\begin{matrix} +10\% \\ -15\% \end{matrix}$, 50, 60Hz $\pm 3\%$, 1 ϕ (However, combination with 220V and 50Hz is disapproved.)
Power source input for servo unit only is applied as followings or not. AC 200/220V $\begin{matrix} +10\% \\ -15\% \end{matrix}$, 50, 60Hz ± 1 Hz 3 ϕ (However, combination with 220V and 50Hz is disapproved.)
In case of using transformer for export, power source input is applied as followings or not. AC 200/220/230/240/380/415/440/450/480/550V $\begin{matrix} +10\% \\ -15\% \end{matrix}$
Input power source capacity is enough or not for consumption electric power of control unit and servo unit.
Phase roto-meter is connected at the input terminal UVW in orders from R, S and T as shown at the figure, and it is required to connect the input below power source so as to rotate the disc of the phase roto-meter as same rotation in clock wise. (For H series)
<p style="text-align: center;">Input Terminal</p> <p style="text-align: center;">U V W G</p> <p style="text-align: center;">Power supply</p> <p style="text-align: center;">T S R</p> <p style="text-align: center;">Phase rotation meter</p>
Phase rotation of power source transformer primary side middle tap for servo is right or not. (H series)
Phase rotation of power source transformer secondary side is in order R \rightarrow S \rightarrow T or not. (H series)

(8) Confirmation is made for that output voltage is not shorted with ground

Items
Power unit output +5 V is shorted with 0V or not.
Power unit output +24 V is shorted with 0V or not.
Power unit output +15 V is shorted with 0V or not.
Power unit output -15 V is shorted with 0V or not.

(9) Power on and check output voltage

Items		
Fans in locker operate or not.		
At the check terminal on master P.C.B., confirm that output voltage is applied within the ranges as described in the right side table. In regard to +5V, adjustment should be made to enter within the range shown in right side table by the variable resistor +5 ADJ on power unit P.C.B.	+5V (C12)	+4.75 ~ +5.25V
	+24V (C12)	+21.6 ~ +26.4V
	+15V (C12)	+14.25 ~ +15.75V
	-15V (C12)	-14.25 ~ -15.75V
Confirm each voltage at check terminal on velocity control P.C.B. of X axis and Z axis. (H series)	CH15 (+24V)	23 ~ 27V
	CH16 (+15V)	14.55 ~ 15.45V
	CH17 (-15V)	-14.55 ~ -15.45V
Confirm each voltage at check terminal on velocity control P.C.B. of X axis and Z axis. (M series)	CH15 (+24V)	22 ~ 27V
	CH16 (+15V)	14.5 ~ 15.5V
	CH17 (-15V)	-14.5 ~ -15.5V

(10) Adjustment of velocity control unit

Items
<p>◦ Adjustment is performed for dither of velocity unit (A20B-0007-0360, 1) (Refer to Item 6.2)</p> <p>(1) Connect CH8 with 0V (CH3 or CH4). Adjust RV3 for voltage of CH9 so as to be 1.5V (50Hz), 3.0V (60Hz).</p> <p>(2) Adjust RV10A, B, C, RV11A, B, C so as to have set value of "0" level width of CH13A, B, C (connect CH8 with 0V (CH3 or CH4)).</p> <p>Set values of 0 level width 50Hz . . . 2.1 ms 60Hz . . . 1.8 ms</p> <p>RV10A, B, C: For adjustment of width RV11A, B, C: When rising of '0' level is made with these controls so that it may be unified</p> <div style="text-align: center;"> </div> <p>Remarks: In case of impossible set within variable range of RV10A, B, C it allows to change the voltage of CH9 within ±0.5V.</p>

Items
<p>Confirm servo offset</p> <p>(a) RV2 on velocity control PCB is set to 50%.</p> <p><i>Note 1: When machine move during adjustment, position deviation error at stop condition or drift excessive error will occur. In that case, set approx. 5000 to inposition limit and position deviation limit. After adjustment, reset normal data. If the large data is set to inposition limit, automatical drift compensation is not performed.</i></p> <p><i>Note 2: Don't short CH2 (TSA) and CH3 (0V) or CH2 and CH4 (0V) on velocity control PCB. If it shorted, hybrid IC on master PCB will be damaged.</i></p>

(11) Adjustment of photo Amp. output wave form of tape reader (Refer to Item 3.5)

Items
<p>After setting color endless tape repeating respectively punching and non punching, and send the tape by setting switch for MANUAL.</p> <p>(1) With an oscilloscope, measure the waveform between check terminals CHPS and CHG (ground) on the photo-amplifier. Adjust it so that the ON/OFF timing ratio is 6:4.</p> <p>(2) Measure the waveform between check terminals CH1 and CH8 on the photo-amplifier using oscilloscope, and find the channel where the ON width is the shortest.</p> <p>(3) Measure the waveform where the ON width is the shortest between CH1 and CH8 and compare it with the waveform of CHPS. Adjust so that the timing indicated in the diagram below is obtained.</p> <p>(4) Confirm that the waveforms CH1 and CH8 satisfy the timing in the diagram below.</p> <div style="text-align: center;"> <p>The diagram shows two square wave pulses. The top pulse is labeled 'CHPS waveform' with 'ON: OFF = 6:4'. The bottom pulse is labeled 'Shortest ON width measured between CH1 and CH8'. Both pulses have an 'ON' period and an 'OFF' period. Arrows indicate that the ON width is 'Above 300µs' and the OFF width is 'Above 300µs'.</p> </div> <p><i>Note) Names of check terminal and variable resistor for tape reader (A13B-0070-B001) are changed as below. CHPS → S (CH1 ~ CH8 → 1 ~ 8 CHG → 0V RV1 → RV2 → right side volume of SP.</i></p>

(12) Confirm interface with NC and machine side

Items
It refer to the self diagnostic function table (See Item 3.7).

(13) Setting and confirmation should be made for each parameter and setting data

Items
<p>It refer to the parameter table. (Refer to Item 5)</p> <p>Set parameter ADFT (PRM, 006, upper bit) at "1".</p>

(14) Power off

(15) Connect motor drive line7

Items
S20 on X and Z axes velocity control unit PCB (A20B-0007-0360.1) is set SHORT. S23 on X and Z axes velocity control unit PCB (A20B-0009-0320) is set OPEN.

(16) Power on

Items
When alarm occurred, it should be processed according to alarm table.
Motor rotates little bit when MCC in velocity control PCB is on. But motor shaft returns position by automatic drift compensation function. Initial and after that, motor shall not rotate by power ON/OFF condition. Confirm that motor shall not rotate by power ON/OFF or emergency condition.

(17) Check movement of each axis by manual feed

Items
To try to move every 10 μ m by manual feed or incremental feed. At this time, confirm that machine movement is correctly following or not by indication the machine current position (DGN X: 820 Z: 821) with MDI/CRT.
Move a machine by JOG feed in low override and operate the limit switch mounting the machine, check that machine exactly stops at the time of over travel alarm detection.
Move a machine by JOG feed and manual rapid traverse and check that error excessive alarm does not occur in maximum feed rate.

(18) Adjustment for servo system

Items
Move a machine by F4 digit feed in MDI mode, at this time observe the position deviation value by MDI/DPL unit (DGN X: 800 Y: 801 Z: 802). The position gain is obtained from the following formula. $G = \frac{16.7F}{E}$ where F: Feed rate [mm/min], [0.1 in./min], [deg./min] E: Position deviation [0.001 mm] [0.0001 in.], [0.001 deg.] G: Position gain [S ⁻¹] Adjust the position gain within +10% of the target value by the tachogenerator compensation adjustment variable resistor (RV4) in the velocity control unit. However, difference between axes must be within 1%. Consider initial value of position deviation.
In case of having inconvenience at the standard setting of velocity control unit (deposit feeding, swell, hunting, overshoot, oscillations and noise etc.), it is necessary to perform setting so as to match mechanical characteristics.
With S4-digit (Analog output) option, set a data to parameter 119 so that voltage between check terminal VCMDZ (3rd axis) and GND (ground) on the master PCB is 0V.
Perform the adjustment and setting for inductosyn/resolver interface PCB. (Refer to item 6.1.6)

(19) Confirm that all functions of NC are able to normally operate or not

Items
Perform a reference point return. Perform setting of grid shift amount. This performance shall not become effective otherwise power goes off once and power goes on again. Function confirmation is necessarily required.
By the test tape being made to match machine, running is made.

4.2 Connection of power supply

4.2.1 Tap change of control power transformer

A control power transformer is required when the input power supply is other than AC 200V 50/60Hz or AC 220V 60Hz.

This transformer can be installed in the free standing type cabinet. As a power transformer is mounted in the mounted in the machine tool when the other type cabinets are used, refer to the manual issued by the machine tool builder.

Check the transformer tap, and confirm that the voltage (at the NC power supply terminal) is within +10% and -15% of the tap voltage. If the voltage is outside this range, the tap must be changed.

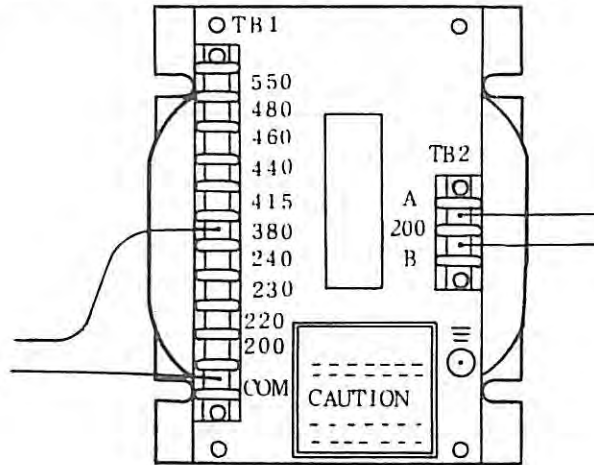

Tap connection for 380V

4.2.2 Tap change of transformer for tape reader with reels

When input voltage is AC 220V for NC, change the tap to 220V tap of transformer for tape reader with reel.

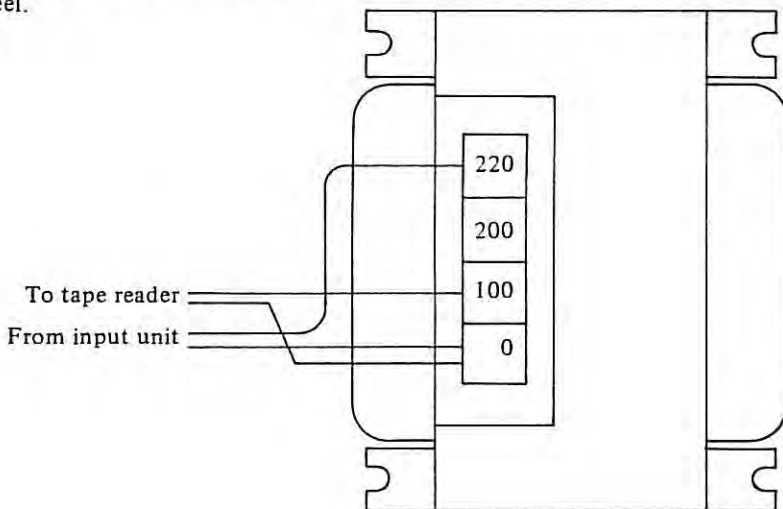

Tap change of transformer for tape reader with reels (In case input voltage is AC 220V)

4.2.3 Tap change of servo transformer (H series)

Check the primary tap connection and confirm that the deviation of supplied voltage is within the range of +10% and -15% of the tap voltage.

If this condition is not satisfied, the connection should be changed to the proper tap.

Supplied voltage	Primary tap connection	
	Domestic use	For export
200V	U-2, W-6, V-4	U-3-6, W-19-23, V-11-15, 4-12-20, 8-16-24, 20-24
220V	U-1, W-5, V-3	U-2-6, W-18-22, V-10-14, 4-12-20, 8-16-24, 20-24
380V		U-3, W-19, V-11, 4-7, 12-15, 20-23, 8-16-24
420V		U-3, W-19, V-11, 4-6, 12-14, 20-22, 8-16-24
460/480V		U-2, W-18, V-10, 4-6, 12-14, 20-22, 8-16-24
550V		U-1, W-17, V-9, 4-5, 12-13, 20-21, 8-16-24

For Japanese use (A80L-0001-0079 ~ 0082)

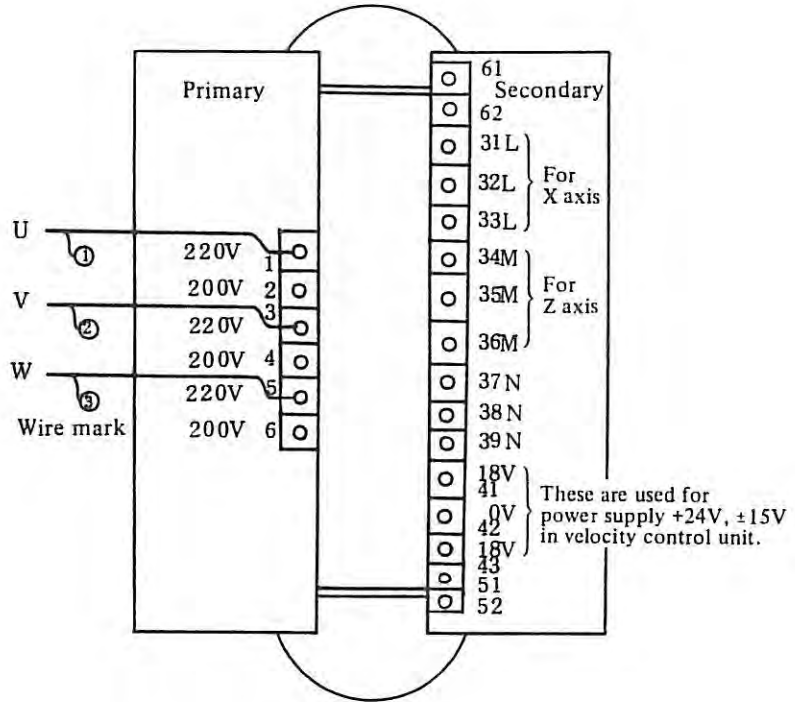

Fig. 4.2.2 (a) Tap connection for 220V

For other countries use (A80L-0001-0083, 0084)

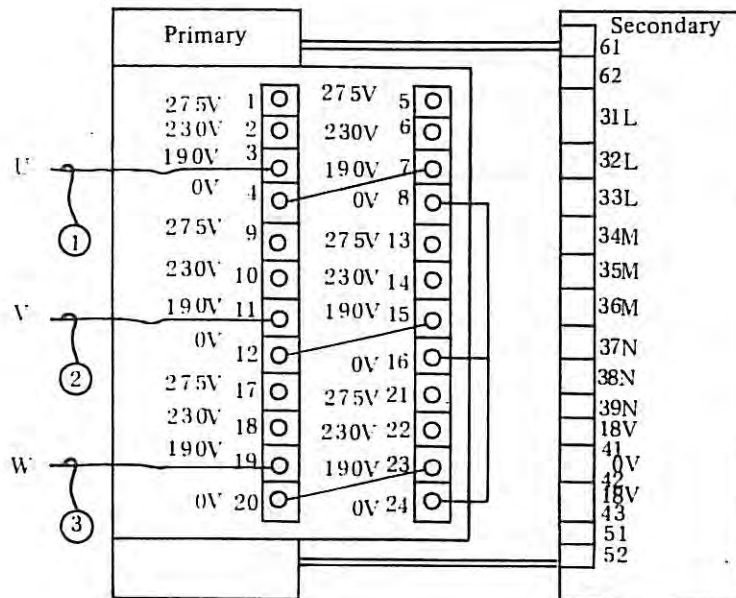

Fig. 4.2.2 (b) Tap connection for 380 V

Connection diagram of transformer
 For Japanese use (A80L-0001-0079 ~ 0082)

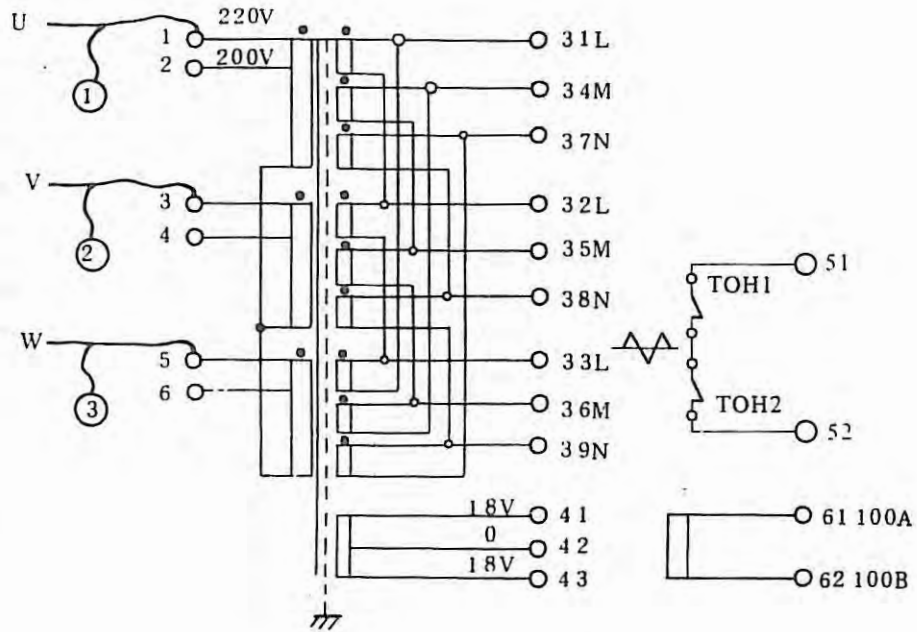

Fig. 4.2.2 (c) Tap connection for 220V

For other countries use (A80L-0001-0083, 0084)

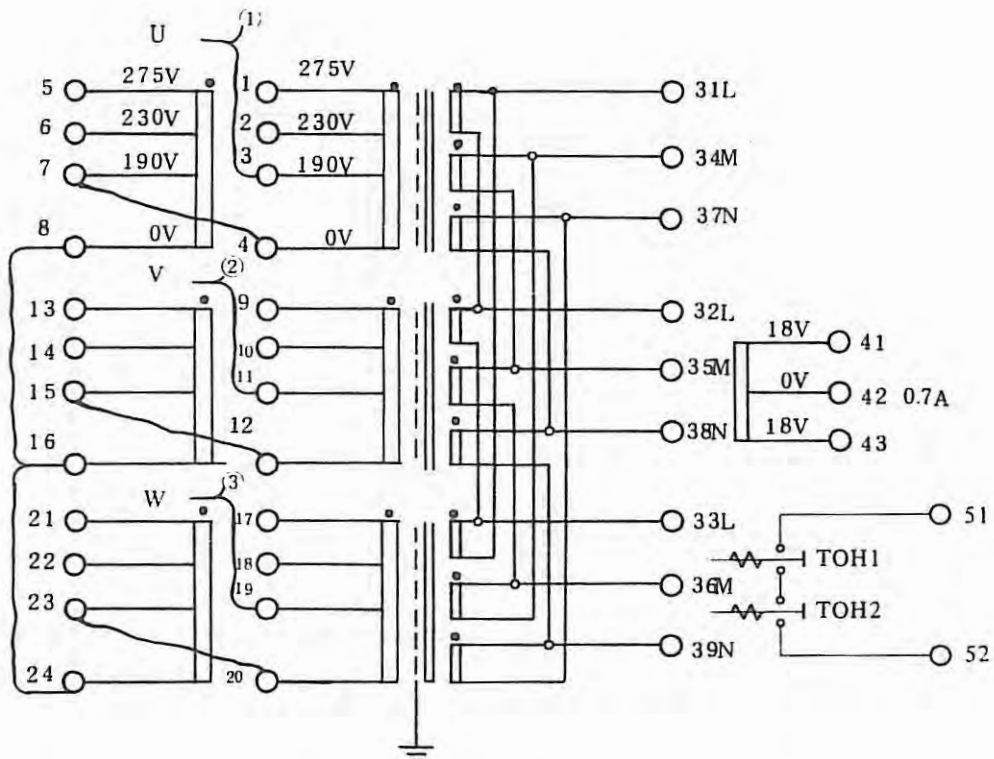

Fig. 4.2.2 (d) Tap connection for 380V

- Notes: 1. When the tap is changed, the input power to the NC unit should always be cut off.
 2. U, V, and W in Fig. 4.2.2 (a) ~ 4.2.2 (d) correspond to input power supply terminals U, V, and W.
 3. Secondary voltage for servo transformers differs according to the motor model as follows:

DC motor model	Secondary voltage
Model 0	60V
Model 5	90V
Model 10	90 or 120V
Model 20, 30, 10H	120V

4.2.4 Connections of power transformer (M series)

(1) Primary connections

(a) For power transformers MA ~ MC (for Japan)

Power voltage	Connection of transformer primary terminals
200V	U-2, V-4, W-6
220V	U-1, V-3, W-5

(b) For power transformers MAE ~ MCE (for countries other than Japan)

Power voltage	Connection of transformer primary terminals	
	Connection of power cables U, V, W	Jumper between transformer terminals
190V (Common to 200V)	U-3-7, V-11-15, W-19-23	4-8-12-16-20-24
230V (Common to 220V)	U-2-6, V-10-14, W-18-22	
380V	U-3, V-11, W-19	4-7, 12-15, 20-23, 8-16-24
420V (Common to 415V, 440V)	U-3, V-11, W-19	4-6, 12-14, 20-22, 8-16-24
460V (Common to 480V)	U-2, V-10, W-18	4-6, 12-14, 20-22, 8-16-24
550V	U-1, V-9, W-17	4-5, 12-13, 20-21, 8-16-24

(2) Secondary connections

(a) For power transformers MA, MAE

(b) For power transformers MB, MC, MBE, MCE

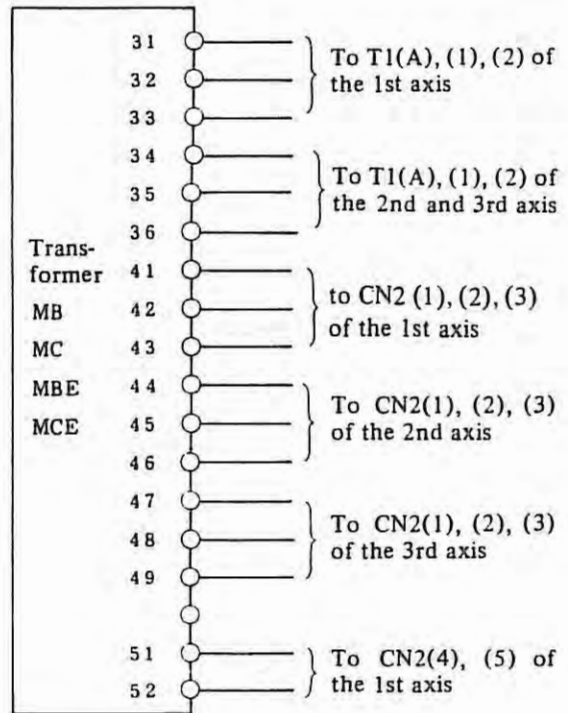
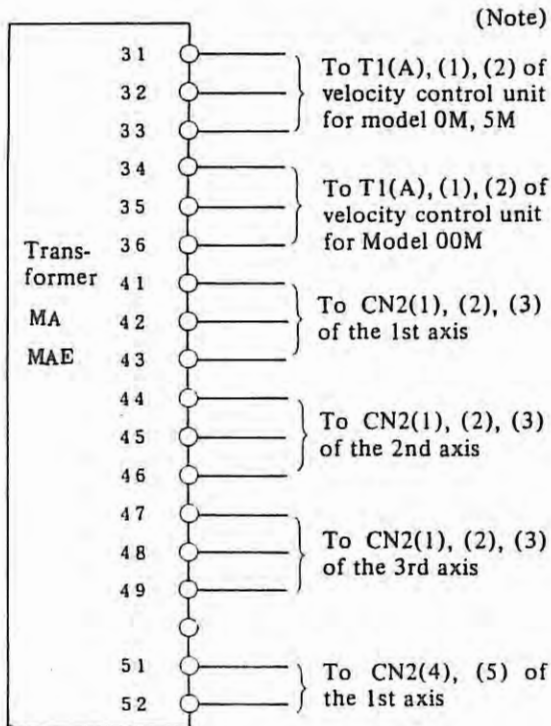

Note:

The output voltage of the power transformer differs for Model 00M.

(The voltage lower than the voltages for other motors is employed)

If the power transformer for other motors should be connected to the velocity control unit for Model 00M by mistake, it causes a trouble. Particularly be careful with connection, accordingly.

(3) Power transformer outer dimension and connection

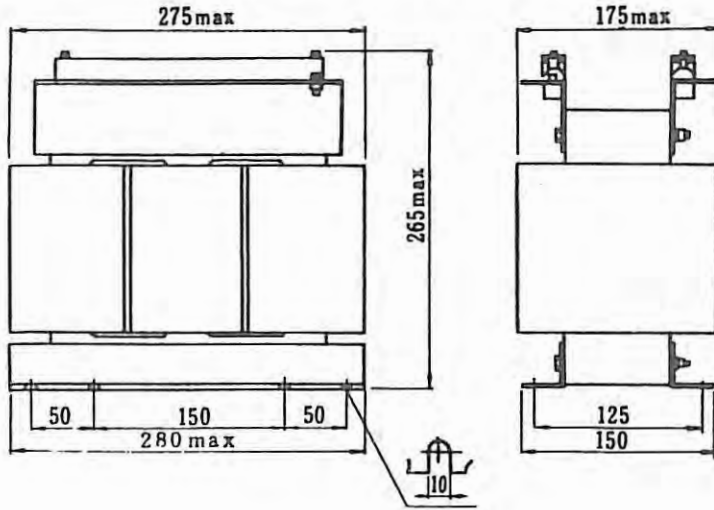

Power transformer	Weight
MA MAE	About 20kg
MB MBE	About 30kg
MC MCE	About 36kg

Connection diagram of power transformer MA ~ MC
Connections of MA 31 ~ 36 are as shown in the right figure.

Connections of power transformer MA 31 ~ 36

Terminal layout of power transformers MA ~ MC (Screw M4)

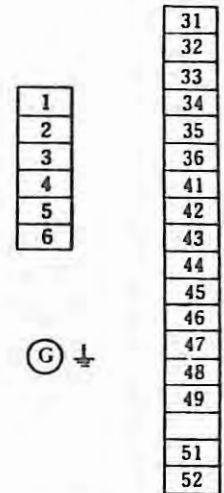
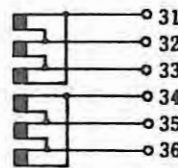
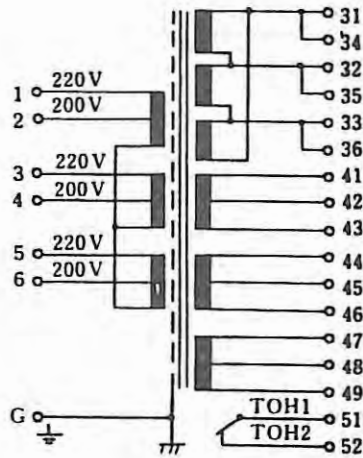

Connection diagram of power transformers MAE ~ MCE
Connections of MAE 31~36 are as shown in the right figure.

Connections of power transformer MAE 31~36

Terminal layout of power transformers MAE ~ MCE

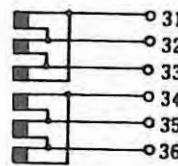
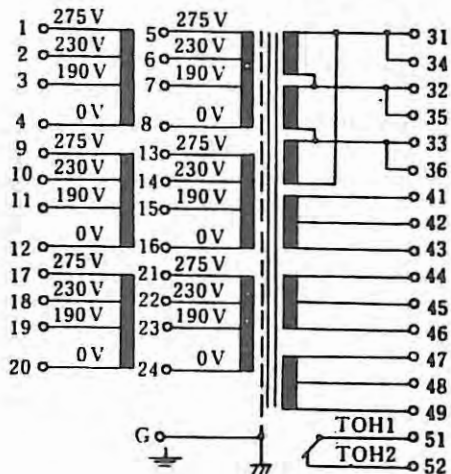
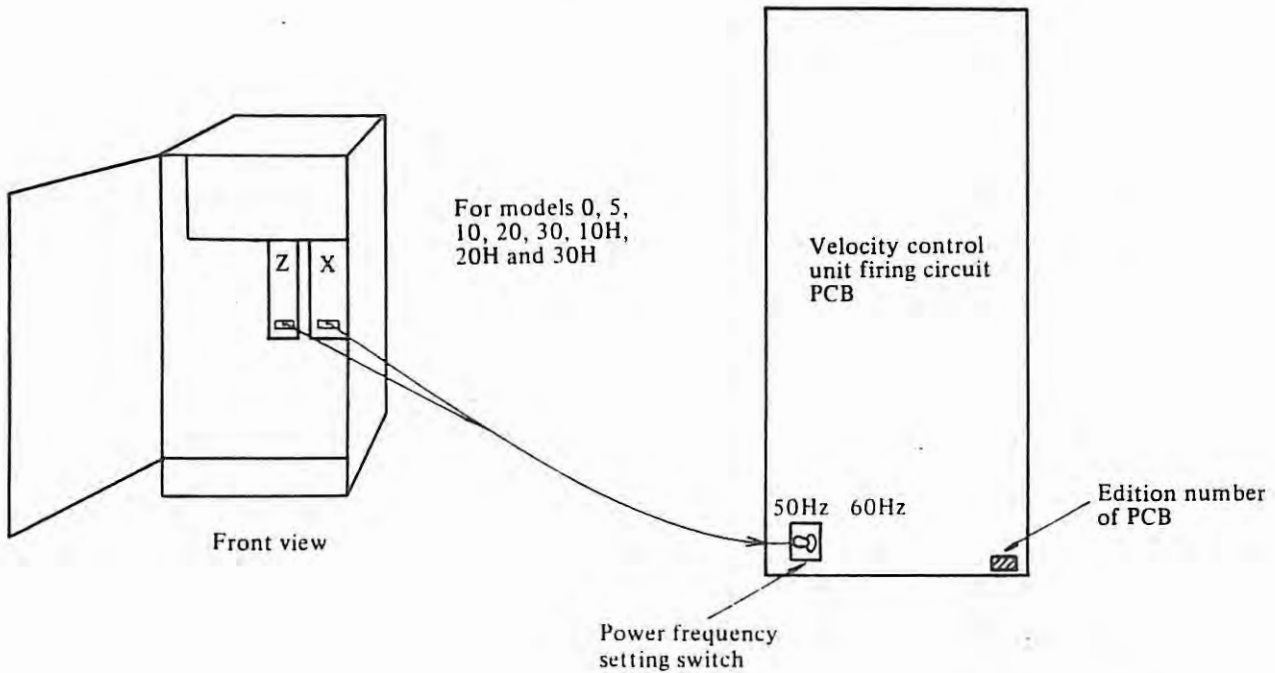

Fig. 8.3

4.3 Frequency setting for velocity control

Examine the input power frequency and confirm whether the power frequency setting switch on the velocity control unit PCB accords with the input power frequency.



Connection of input power supply, phase rotation

Connect the power supply and the ground to the power terminals U, V, W and G. When a servo unit is mounted in the free standing type cabinet, or in the built-in type 2 cabinet, connect them so that the phase rotation is in the order of U, V and W.

○ How to set phase rotation

Connect a phase meter as follows and get the connection of power supply so as to observe the clockwise rotation of the indicator. Misconnection of power supply with respect to the phase rotation will cause the blow out of fuses on the velocity control unit (F1, F2 and F3).

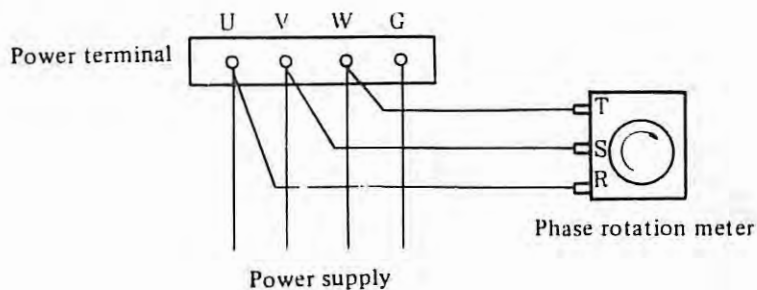

5. SETTING OF PARAMETERS

When connect a NC and servo motor or NC and machine, set the parameter to make the machine exhibit the best-performance. Setting data for parameter depend on machine. Refer to parameter table made by machine builder.

5.1 Procedure of display of parameters

- (1) Push the button on the MDI & CRT unit.
Parameters are displayed on the screen.

There are following 2 methods to change the screen.

Method 1

Pressing the PAGE button displays changes in the forward direction.

Pressing the PAGE button displays changes in the reverse direction.

Method 2

Press the key, parameter number via the DATA key, then key. The Corresponding parameter number is displayed.

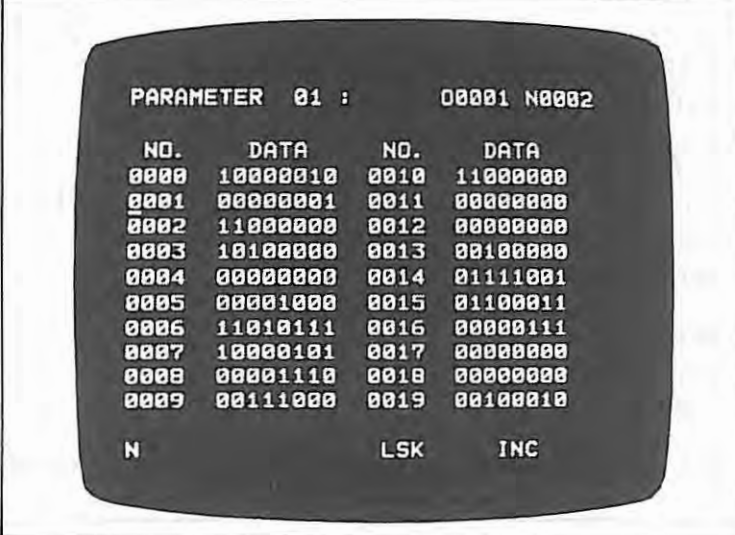

PARAMETER 01 : 00001 N0002

NO.	DATA	NO.	DATA
0000	10000010	0010	11000000
0001	00000001	0011	00000000
0002	11000000	0012	00000000
0003	10100000	0013	00100000
0004	00000000	0014	01111001
0005	00001000	0015	01100011
0006	11010111	0016	00000111
0007	10000101	0017	00000000
0008	00001110	0018	00000000
0009	00111000	0019	00100010

N LSK INC

Example of parameter display

5.2 Procedure of setting of parameters

5.2.1 Setting via the MDI

- (a) Set a selector switch on the master PCB to ENABLE. The alarm number 100 is displayed.

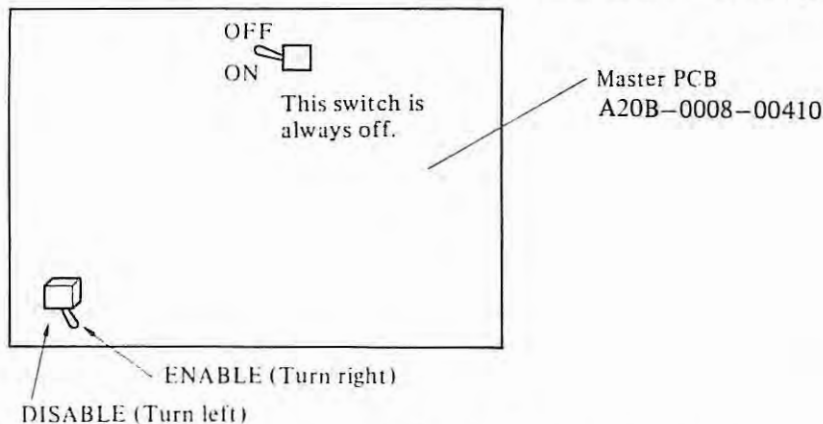

- (b) Set MODE switch on the control panel to MDI or set to Emergency stop state.
 (c) Display a parameter referring to item 5.1.
 (d) Select a parameter number by **CURSOR** button or by pressing **N** followed by pressing parameter number and **INPUT** key.
 (e) Press **P** key, then input data.
 The keyed-in data is displayed at the button on the screen.
 The erroneous data can be cancelled by the push of **CAN** key.
 (f) Press **INPUT** key to finish a setting. Confirm your setting.
 (g) Set a selector switch on the master PCB to DISABLE after all parameters have been set.
 (h) Release emergency stop if it is on.
 (i) Push the **RESET** key to release the alarm status (No. 100).

5.2.2 Setting via the tape

Parameters can also be input via the tape.

- (1) Prepare the tape for parameter as follows.

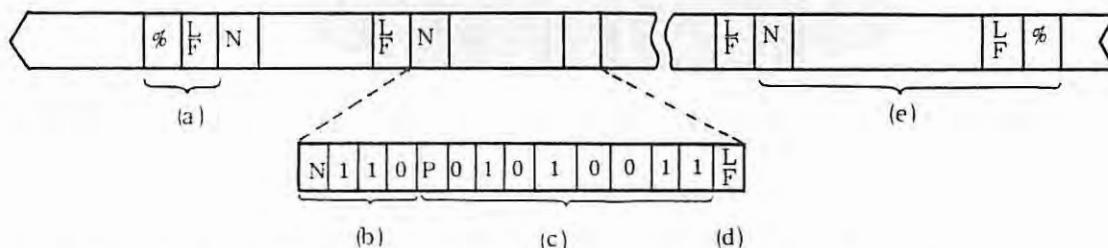

- (a) Punch % LF (for ISO code) or ER CR (for EIA code) at the start of tape
 (b) Punch the parameter number following the address N after the LF (or CR) code.
 (c) Punch the parameters corresponding to the parameter number following the address P.
 (d) Punch LF (or CR)
 Repeat (b) through (d) by the times required.
 Leading zeros of the parameters can be omitted.
 (e) Punch LF % (or CRER) at the end.
 Parameters not punched on the tape do not change after the tape is read into the NC. So you can prepare several tapes; one is for backlash compensation data, one is for pitch error compensation data, etc.

- (2) Procedures.

A parameter tape is read into the NC by the following procedures:

- ① Set a selector switch on the master PCB to ENABLE. The "ALM" characters are displayed in CRT.
- ② Set a parameter tape in the tape reader.
- ③ Push the EMERGENCY STOP button.

- ④ Select the Page of parameter in MDI/CRT unit.
- ⑤ Input and -9999 by the DATA key in MDI/CRT unit.
- ⑥ Push the READ button. A parameter tape is read into automatically.
- ⑦ Set a selector switch to DISABLE, after terminating of reading.
- ⑧ Release emergency stop and push the RESET button to release the

(Note 1) If the following alarm is detected, reading operation is interrupted, but the alarm is not indicated.

- (i) TH check and TV check (when TV check is effective).*
- (ii) An address other than N or P is commanded.*
- (iii) Data following address N or P is improper.*

(Note 2) Press the RESET button to stop reading-in of parameter tape.

5.2.3 Punch-out of parameter

- (a) Make punch unit ready to punching.
- (b) Set the punching code, EIA or ISO.
- (c) Set the MODE SELECT switch to EDIT mode.
- (d) Select the page of parameter in MDI/CRT unit.
- (e) Input in MDI/CRT unit.

5.3 Parameter table

5.3.1 Parameter table for each number

Number	Contents	Number	Contents
0000-0004	Fixed parameters	0070-0071	In-position width.
0005-0010	Various parameters	0074-0074	Limit value of position deviation at stoppage.
0012	Reference Point Return method, direction.	0078-0079	Limit values of position deviation at during move.
0013	Between spindle and position coder gear ratio, resolver/inductosyn phase shift.	0082-0083	Grid shift amounts.
0014-0015	DMR, reference counter capacities	0086-0087	Servo loop gain multipliers.
0018	Backlash compensation pulse frequency	0090	Loop gain.
0019	MF, SF, TF, BF and FIN time width	0091	Jog feed rate.
0020	Reference point Return function's presence or absence.	0092-0093	Rapid traverse rates.
0021	Associated with S4-digits and with external deceleration.	0096-0097	Linear acceleration/deceleration time constants.
0024-0026	Various parameters	0100-0101	Manual feed acceleration/ deceleration time constants.
0027-0028	CMR	0104	X axis exponential acceleration/ deceleration time constant in thread cutting.
0031-0032	VCMD minimum clamp values	0105	Cutting feed acceleration/deceleration time constant
0035-0036	Nonbuffering M codes.	0106	Cutting-feed upper-limit feed rate.
0037	Number of spindle motor revolutions at spindle gear shift.	0107	Lower limit value of X axis acceleration/deceleration in thread cutting.
0038	Number of spindle revolutions at spindle orientation.	0108	Low limit feed rate at acceleration/ deceleration in cutting feed.
0040	Allowable value at limit check in external tool offset B function	0109-0110	Manual-feed lower-limit feed rate in acceleration/deceleration
0041-0056	Data multiplier for outside diameter measuring in external tool offset B function.	0113	Rapid traverse override minimum feed rate (F 0).
0057-0059	Operating time.	0114	Low feed rates in Reference Point Return
0062	Spindle spdd arrival signal timer	0115-0116	Backlash amounts
0064	Width of chamfering for thread cutting.	0119	Spindle offset compensation value (S analog output)
0065	Return amount in G74, G75.	0120-0123	Spindle speed corresponding with gear 1 ~ 4 when spindle speed command is 10 V.
0066	Finishing allowance at G76.	0124-0125	Drift compensation values
0067	Escaping amount at G72, G72.	0128-0129	Phase shift amounts (resolver/ inductosyn)
0068	Minimum cutting depth at thread cutting cycle G76.		
0069	Move amount ignored at close-to-90° acute angle in cutter compensation		

Number	Contents	Number	Contents
0132	Least spindle revolution number in constant surface speed control mode (G96)	0316	Associated with resolver/inductosyn
0133	Measuring feed rate with automatic tool offset.	0317	Code corresponding to # (user macro)
0140	Spindle speed gain adjustment (S4 analog output)	0319	Associated with user macros.
0141-0142	Operating-time presetting.	0320-0322	M codes calling user macros.
0143-0158	Stored stroke-limit setting.	0323-0332	G codes calling user macros.
0159-0160	2nd reference points.	0340	Input device selection.
0163-0164	The value γ for X axis or Z axis in automatic tool offset.	0341	Output device selection.
0165-0166	The value ϵ for X axis and Z axis in automatic tool offset.	0342	Skipped cutting low feed rate.
0300-0304	Fixed parameters	0343-0346	The lowest spindle in the constant surface speed control to gears 1, 2, 3, 4 in order.
0305-0308	Various parameters.	0375-0376	Automatic coordinate system settings at mm input.
0310-0313	I/O device's baud rates.	0379-0380	Automatic coordinate system Settings at inch input.

5.3.2 Parameter table for each function

(1) Servo

Parameter number	Contents
005	Servo-off signal is effective or not.
006	<ul style="list-style-type: none"> • Automatic drift is compensated or not. • In-position check is performed or not.
013	Phase shift amount is set automatically or not.
014 ? 015	Detect multiply ratio setting.
026	Servo alarm is generated or not if VRDY is on before PRDY is output.
027 ? 028	Command multiply ratio setting.
031 ? 032	Clamp of feed command value setting.
070 ? 071	Width of inposition.
074 ? 075	Limitation value of position deviation amount at stoppage.
078 ? 079	Limitation value of position deviation amount during movement.
082 ? 083	Grid shift amount.
086 ? 087	Servo loop gain multiplier.
090	Servo loop gain.
124 ? 125	Compensation amount of drift.
128 ? 129	Servo phase shift amount.
316	Frequency check of DSCG feed back is performed or not.
"	Position detecting system is resolver or inductosyn or pulse coder.

(2) DC spindle servo

Parameter number	Contents
005	Output for S4 digit option or S code (BCD) output.
009	Sign of output voltage in S4 digit. (analog output)
..	Setting of spindle override function (SOV)
010	Switching of normal close or normal open for spindle stop signal (*SSTP).
037	Spindle motor rev. at spindle gear shift.
038	Spindle speed at spindle orientation.
062	Delay timer in checking the spindle speed arrival signal.
119	Spindle speed offset compensation value (for S4-digit analog output A/B).
120 ? 123	Spindle speed corresponding with gear 1~4 when spindle speed command is 10V.
132	Least spindle revolution number in constant surface speed control mode.
140	Gain adjustment of S4-digit analog output A/B.
307	Clamp value of the lowest speed in S4-digit binary 12 bit output/analogue output is set for all gears in common or is set individually for each gear.
343 ? 346	The lowest spindle speed in the constant surface speed control for each gear.

(3) Reference point return function.

Parameter number	Contents
010	Deceleration signal (*DECX, *DECZ) is "1" in reference point return shows deceleration or "0".
012	Reference point return method and direction.
013	Manual reference point in reverse direction is performed or not.
014~015	Capacity of reference counter for each axis.
020	Reference point return function is provided or not.
082~083	Setting of grid shift amount of each axis.
114	Low feed rate for reference point return.
159~160	Distance from second reference point to first reference point of each axis.

(4) Tool offset

Parameter number	Contents
007	Offset value input by incremental or absolute.
008	Offset value is radius designation or diameter designation.
010	MDI setting is possible or not when lock key is closed.
040	Allowable value at limit check in external tool offset B function (not used).
041~056	Data multiplier for outside diameter measuring in external tool offset B function (not used).
069	Limitations on ignoring a small movement amount in nose R compensation.
133	Setting of measuring feedrate with automatic tool offset option.
164	The value γ for X axis or Z axis in automatic tool offset.
165~166	The value ϵ for X axis or Z axis in automatic tool offset.

(5) Backlash

Parameter number	Contents
012	Initial backlash direction when turning on the power.
018	Backlash compensation pulse frequency. (always 256kHz)
115 ? 116	Backlash amount of each axis.

(6) Canned cycle

Parameter number	Contents
008	Dryrun in thread cutting is effective or not.
009	Canned cycle is repeated even in a no movement command block or not repeated.
064	Width of chamfering for thread cutting (G92, G76).
065	Return amount at G74, G75.
066	Finishing allowance at G76.
067	Escaping amount at multiple repetitive cycle G71, G72.
068	Minimum cutting depth at thread cutting cycle G76.
307	Finishing work of the final rough cutting is executed or not in G71, G72.

(7) Custom macro

Parameter number	Contents
306	Custom macro is called by T code or not.
308	It is possible to read and write DI, DO by a macro variable or not.
317	It registers the code corresponding to “#” used in custom macro.
318	Setting of different parameters for custom macro.
319	”
320 ? 322	Setting of three kinds of M code to call custom macro.
323 ? 332	Setting of ten kinds of G code to call custom macro.

5.4 Details of parameters

- Note 1) Refer to the parameter table attached to the NC for the contents of parameters 0000-0004 and 0300-0304, which vary from machine tool to machine tool.
- Note 2) Set to 0 a parameter whose usage is not described in this table.
- Note 3) Set parameter numbers of

--	--	--	--	--	--	--	--

 and

--	--	--	--	--	--

 of the data indicator in binary expression (0 and 1 only); set a parameter of

--	--	--	--	--	--	--	--

 of the data indicator in decimal expression.
- Note 4) When the parameter has no sign, do not set.
- Note 5) Set 0 for an inhibited parameter.
- Note 6) When the parameter whose range is described is not used, set 0 to the parameter.

	0	0	5		ORWD	EIT	EENB	SCD	FMIC	MDL	MIC	SCW
					7	6	5	4	3	2	1	0

- ORWD** 1: The rewind signal is output only when a tape is rewound by the reset & rewind signal.
0: The rewind signal is output for a certain time (100ms) even when a tape is not rewound by the reset & rewind signal.
- EIT** 1: Interlock signal is effective.
0: Interlock signal is ineffective.
- EENB** 1: Servo-off signal is effective.
0: Servo-off signal is ineffective.
- SCD** 1: Even if S 4-digit (analog output) or S 4-digit (binary 12 bit output) option is selected, S analog output or S 12 bit output is not issued but S code (BCD) is output.
0: If S 4-digit (analog output) or S 4-digit (binary 12 bit output) option is selected, output according to it. Otherwise, S code (BCD) is issued.
- FMIC** 1: Least input increment of feed rate for metric input is 1/10.
0: Least input increment of feed rate for metric input is not 1/10.
- MDL** 1: Least display increment of position display unit for metric input (inch input) is 0.01 mm (0.0001 inch).
0: Least display increment of position display unit for metric input (inch input) is 0.001 mm (0.0001 inch).
- MIC** 1: Least input increment for metric input (inch input) is 0.01 mm (0.0001 inch).
0: Least input increment for metric input (inch input) is 0.001 mm (0.0001 inch).
- SCW** 1: Least command increment is 0.0001 inch. (Machine tool: inch system).
0: Least command increment is 0.001 mm. (Machine tool: metric system).

Always "0"

Always "0"

Refer to Item III-4 in operator's manual.

	0	0	6		ADFT	EOM	CINP	DCS	CLER	TVC	PPD	RDRN
					7	6	5	4	3	2	1	0

- ADFT** 1: Automatic drift is compensated.
0: Automatic drift is not compensated.
- EOM** 1: When an M30 is encountered in the memory mode, the M30 is output to the machine side and then if the NC receives the FIN signal, the execution returns to the head of the program and continues. If the NC does not receive FIN signal but receives an external reset signal, the execution returns to the head of the program and the NC enters the reset status.
0: When an M30 is encountered in the memory mode, the NC outputs M30 to the machine side. But unless the NC receives a reset & rewind signal, the execution does not return to the head of the program.

Refer to parameter No. 124, 125.

- CINP 1: The execution goes to the next block after the feedrate decelerates to zero and moreover the machine enters into the specified range against the commanded position (in-position check) at the interference of two blocks except for the two blocks of feedrate command.
 0: The execution goes to the next block after the feedrate decelerate to zero (no in-position check) at the interference of two blocks except for the two blocks of feedrate command.
- DCS 1: Pushing the START button on the MDI panel directly actuate the NC start without going through the machine side. (MDI mode only)
 0: Pushing the START button on the MDI panel issues the signal to the machine side. The NC start is actuated when the NC receives the start signal from machine side.
- CLER 1: NC becomes Clear state by Reset button, External Reset or Reset & rewind signal.
 0: NC becomes Reset state by Reset button, External Reset or Reset & rewind signal.
- TVC 1: TV check of the information in comment zone is effective.
 0: TV check of the information in comment zone is ineffective.
- PPD 1: Position display unit is preset by G50 (G92).
 0: Position display unit is not preset by G50 (G92).
- RDRN 1: Dry run is effective for rapid traverse.
 0: Dry run is not effective for rapid traverse.

Refer to parameter No. 070, 071.

Refer to appendix 8 in operator's manual.

Only in ISO code.

Same condition as ORIGIN button.

0	0	7	ICR	IOF	GSP	SCTO	G90	G98		G00
			7	6	5	4	3	2	1	0

- ICR 1: LF is punched for an EOB code in ISO code.
 0: LFCRCR is punched for an EOB code in ISO code.
- IOF 1: Offset values (and tool nose R values) are input with incremental value when optional incremental offset function is equipped with.
 0: Offset values (and tool nose R values) are input with absolute value.
- GSP 1: Special G codes are used.
 0: Standard G codes are used.
- SCTO 1: When the movement changes from rapid traverse to cutting feed, the speed arrival signal is checked.
 0: The speed arrival signal is not checked.
- G90 1: Initial state becomes G90 (special G code) when the power is turned on, or in the clear status.
 0: Initial state becomes G91 (special G code) when the power is turned on, or in the clear status.
- G98 1: Initial state becomes G98 when the power is turned on, or in the clear status.
 0: Initial state becomes G99 when the power is turned on, or in the clear status.
- G00 1: Initial state becomes G00 when the power is turned on, or in the clear status.
 0: Initial state becomes G01 when the power is turned on, or in the clear status.

Refer to Item 5 in operator's manual.

0	0	8	ORC	RWL		TLCC	T2D	TOC	MMTN	TDRN
			7	6	5	4	3	2	1	0

- ORC 1: Offset value becomes a radius designation.
 0: Offset value becomes a diameter designation.
- RWL 1: Inhibit area of stored stroke limit 3 is outside.
 0: Inhibit area of stored stroke limit 3 is inside.
- TLCC 1: New offset value is effective from the next block when offset value is altered.

Refer to Item III-6.1 in operator's manual.

- 0: New offset value is effective from the next T code when offset value is altered.
- T2D 1: Lower 2 digits are offset number in T code. (2 + 2 digits)
- 0: Lower 1 digit is offset number in T code. (1 + 1 digits)
- TOC 1: Offset is canceled by Reset button.
- 0: Offset is not canceled by Reset button.
- MMTN 1: M, S and T commands are executed but move command is not when STLK signal is ON.
- 0: Move command, M, S, and T commands are not executed when STLK signal is ON.
- TDRN 1: Dry run in thread cutting is effective.
- 0: Dry run in thread cutting is ineffective.

	0	0	9		TCW	CWM	SOV	SSCR	MOR	SOVC	REDT	ISOT
					7	6	5	4	3	2	1	0

TCW, CWM

Polarity of the output signal of the S-4 digits code
(analog output)

Parameter		Polarity	
TCW	CWM	M03	M04
0	0	+	+
0	1	-	-
1	0	+	-
1	1	-	+

- SOV 1: Spindle speed override is effective.
- 0: Spindle speed override is ineffective.
- SSCR 1: In the constant surface speed control, the surface speed is calculated from the block end point coordinate value of the X axis if the block is the rapid traverse command.
- 0: In the constant surface speed control, the surface speed is calculated continuously according to the coordinate value of the X axis even if the block is the rapid traverse command, as well as the block of the cutting feed.
- MOR 1: In canned cycle mode, specified canned cycle is repeated even in a no movement command block.
- 0: In no movement command block canned cycles are not done.
- SOVC 1: During thread cutting (G32, G76, G92), spindle override is changed at 100%.
- 0: Even thread cutting, spindle override is not clamped at 100%.
- REDT 1: Storage of program to memory is started by pressing the cycle start button in EDIT mode.
- 0: Storage of program to memory is not started by pressing the cycle start button in EDIT mode.
- ISOT 1: When the stored stroke limit option is provided, manual rapid traverse become effective without performing reference point return.
- 0: When the stored stroke limit option is provided, manual rapid traverse doesn't become effective without performing reference point return.

	0	1	0		DGNE	SETE	DECI	SSPB	NPRD	PROD	CTHD	
					7	6	5	4	3	2	1	0

- DGNE 1: Data output is effective in DIAGNOSE.
- 0: Data output is ineffective in DIAGNOSE.
- SETE 1: MDI setting is possible when lock key on the machine side is closed.
- 0: MDI setting is impossible when lock key on the machine side is closed.

- DECI 1: Deceleration signal "1" in reference point return shows deceleration.
 0: Deceleration signal "0" in reference point return shows deceleration.
- SSPB 1: Normal close contact is used for spindle stop signal "SSTP".
 0: Normal open contact is used for spindle stop signal "SSTP".
- NPRD 1: Decimal point input and display is not used.
 0: Decimal point input and display is used.
- PROD 1: The programmed position is displayed on the position display.
 0: The position in which the tool offset and tool nose radius compensation are added is displayed on the position display.
- CTHD 1: Continuous thread cutting is possible (Not used.).
 0: Continuous thread cutting is impossible.

	0	1	2			ZGMZ	ZGMX				ZMZ	ZMX
				7	6	5	4	3	2	1	0	

ZGMX, ZGMZ X axis, Z axis reference point return method in order.

- 1: Magneswitch method
 0: Grid method

ZMX, ZMZ X axis, Z axis reference point return direction in order, and the initial backlash direction when turning on the power.

- 1: Reference point return direction and the backlash direction are minus.
 0: Reference point return direction and the backlash direction are plus.

(Note 1) For the axis with the function of reference point return, the reference point return direction and the initial backlash direction are same. For the axis without it, this parameter specifies only the initial backlash direction.

(Note 2) The backlash compensation is initially performed when the axis moves in the opposite direction against the direction which is set by this parameter after the power is turned on.

Refer to Item 4.1.

Refer to parameter No.082, 083.

	0	1	3	PSG2	PSG1	RVZRN	PHS					
				7	6	5	4	3	2	1	0	

PSG2, PSG1

Magnification	PSG2	PSG1
x 1	0	0
x 2	0	1
x 4	1	0
x 8	1	1

$$\text{Magnification} = \frac{\text{Number of spindle rotation}}{\text{Number of position coder rotation}}$$

PHS Initial setting of phase shift amount in resolver/inductosyn.

- 1: Not set automatically.
 0: Set automatically. After setting the amount, this data is set "1" automatically.

RVZRN In manual reference point return.

- 1: It is not performed in reverse direction.
 0: It is performed in reverse direction.

	0	1	4			DMRX					GRDX	
				7	6	5	4	3	2	1	0	

	0	1	5			DMRZ					GRDZ	
				7	6	5	4	3	2	1	0	

DMRX, DMRZ Command multiply ratio for X-axis and Z-axis in order.

Setting code			Multiply ratio	
			Pulse coder	Resolver/inductosyn
0	0	0	1/2	1/8
0	0	1	1	1/4
0	1	0	1	1/4
0	1	1	2	1/2
1	0	0	3/2	3/8
1	0	1	3	3/4
1	1	0	2	1/2
1	1	1	4	1

Standard setting code is 110 for resolver/inductosyn

GRDX, GRDZ Capacity of reference counter for X axis and Z axis in order.

Capacity of reference counter = Command multiply ratio × 2000
(For pulse coder 2000 ppr)
= Command multiply ratio × 2500
(For pulse coder 2500 ppr)

Setting code in binary	One cycle capacity
0001	2000
0010	3000
0011	4000
0100	5000
0101	6000
0111	8000
1001	10000

Standard setting code 0001 for resolver/inductosyn

(Note 1) If the code other than codes in the above table is set, capacity is set 8000.

(Note 2) DMR and GRD are set with the binary number.

Metric system

Moving distance per 1 revolution of motor (Pulse coder)	Axis	Counting unit (m)	Command multiply ratio (CMR)	Detect multiply ratio (DMR)			Capacity of reference counter
				Pulse coder 2000	Pulse coder 2500	Pulse coder 3000	
12 mm	X	1	1/0.5			4	6000
	Z	1	1			4	6000
10 mm	X	1	1/0.5		4		10000
	Z	1	1		4		10000
8 mm	X	1	1/0.5	4			8000
	Z	1	1	4			8000
6 mm	X	1	1/0.5	3		2/4	6000
	Z	1	1	3			6000
5 mm	X	1/0.5	1		2/4		5000/10000
	Z	1	1		2		5000
4 mm	X	1/0.5	1	2/4			4000/8000
	Z	1	1	2			4000
3 mm	X	1/0.5	1	1.5/3			3000/6000
	Z	1	1	1.5			3000
2 mm	X	1/0.5	1	1/2			2000/4000
	Z	1	1	1			2000
1 mm	X	0.5	2/1	1			2000
	Z	0.5	2	1			2000

Note 1) Right side diameter designation, left side is radius designation is X axis.

Note 2) Data in above table is standard. Command and detect multiplying ratio can be changed, but in that case there is limit for maximum feed rate.

Moving distance per 1 revolution of motor (Pulse coder)	Axis	Counting unit (m)	Command multiply ratio (CMR)	Detect multiply ratio (DMR)			Capacity of reference counter
				Pulse coder 2000	Pulse coder 2500	Pulse coder 3000	
0.6 inch	X	1/0.5	1	3		4	6000
	Z	1	1	3			6000
0.5 inch	X	1/0.5	1		2/4		5000/10000
	Z	1	1		2		5000
0.4 inch	X	1/0.5	1	2/4			4000/8000
	Z	1	1	2			4000
0.3 inch	X	1/0.5	1	1.5/3			3000/6000
	Z	1	1	1.5			3000
0.25 inch	X	1/0.5	1		1/2		5000
	Z	0.5	2		2		5000
0.2 inch	X	1/0.5	1	1/2			2000/4000
	Z	1	1	1			2000
0.15 inch	X	0.5	2	1.5			3000
	Z	0.5	2	1.5			3000
0.1 inch	X	0.5	2	1			2000
	Z	0.5	2	1			2000

Note 1) Right side diameter designation, left side is radius designation is X axis.

Note 2) Data in above table is standard. Command and detect multiplying ratio can be changed, but in that case there is limit for maximum feed rate.

Resolver/Inductosyn (Metric, Inch system)

Moving distance per 1 revolution of detector	Axis	Counting unit	Command multiply ratio (CMR)	Detect multiply ratio (DMR)	Capacity of reference counter
2 mm	X	1	1	0.5	2000
	Y	1	1	0.5	2000
	Z	1	1	0.5	2000
	4	1	1	0.5	2000
0.2 inch	X	1	1	0.5	2000
	Y	1	1	0.5	2000
	Z	1	1	0.5	2000
	4	1	1	0.5	2000

(c) Multipole resolver
Metric system

Moving distance per 1 revolution of motor	Kind of resolver	axis	CMR	DMR	Counting unit (μm)	Capacity of reference counter	Loop gain multiplier	
							7V/2000 rpm	7V/1000 rpm
10 mm	5X	X	1	1	0.5	4000	358	717
		Z	1	1/2	1	2000	717	1434
8 mm	4X	X	1	1	0.5	4000	448	896
		Z	1	1/2	1	2000	896	1792
6 mm	3X	X	1	1	0.5	4000	597	1195
		Z	1	1/2	1	2000	1792	2389
5 mm	5X	X	1	1/2	0.5	2000	717	1434
		Z	1	1/2	0.5	2000	717	1434
4 mm	4X	X	1	1/2	0.5	2000	896	1792
		Z	1	1/2	0.5	2000	896	1792
3 mm	3X	X	1	1/2	0.5	2000	1195	2389
		Z	1	1/2	0.5	2000	1195	2389

Inch system

Moving distance per 1 revolution of motor	Kind of resolver	axis	CMR	DMR	Counting unit ($\times 10^{-4}$ inch)	Capacity of reference counter	Loop gain multiplier	
							7V/2000 rpm	7V/1000 rpm
0.5 inch	5X	X	1	1/2	0.5	2000	717	1434
		Z	2	1/2	0.5	2000	717	1434
0.4 inch	4X	X	1	1/2	0.5	2000	896	1792
		Z	2	1/2	0.5	2000	896	
0.3 inch	3X	X	1	1/2	0.5	2000	1195	2389
		Z	2	1/2	0.5	2000	1195	2389
0.25 inch	5X	X	2	1/2	0.25	2000	717	1434
		Z						
0.2 inch	4X	X	2	1/2	0.25	2000	896	1792
	5X	Z	5	1/2	0.2	2000	717	1434
0.15 inch	3X	X	2	1/2	0.25	2000	1195	2389
		Z						

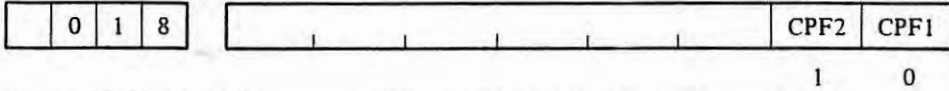

CPF2, CPF1 Backlash compensation pulse frequency (common to all axes.)

Frequency KHZ	CPF2	CPF1
32	0	0
64	0	1
128	1	0
256	1	1

Standard setting value is 256kHz.

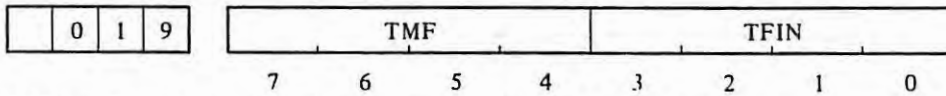

TMF Time from M, S, T code issue to MF, SF, TF issue 16 ~ 256m sec (16m sec increment)

TFIN Time of reception width of FIN 16 ~ 256m sec (16m sec increment)

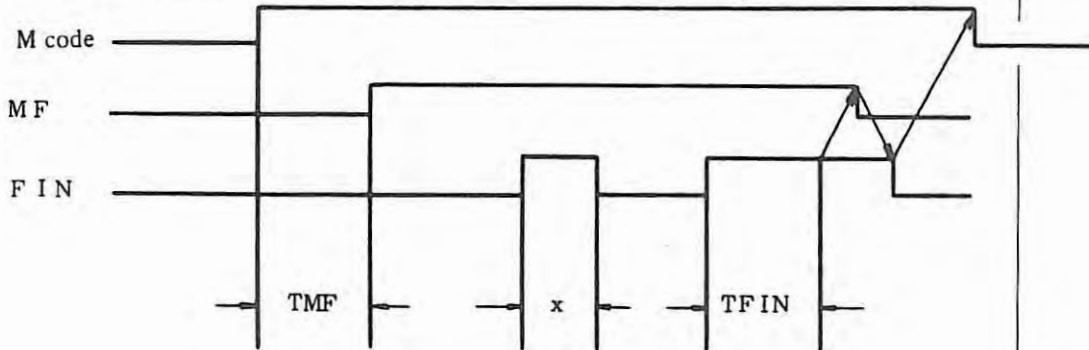

Because of $x < TFIN$, it is neglected.
 TMF or $TFIN = 16 \times (N + 1)$ ms ($N = 1 \sim 15$)

TMF	TFIN	Parameter setting			
		0	0	0	0
16 (msec)	More than 16 (msec)	0	0	0	0
32	" 32	0	0	0	1
48	" 48	0	0	1	0
64	" 64	0	0	1	1
80	" 80	0	1	0	0
96	" 96	0	1	0	1
112	" 112	0	1	1	0
128	" 128	0	1	1	1
144	" 144	1	0	0	0
160	" 160	1	0	0	1
176	" 176	1	0	1	0
192	" 192	1	0	1	1
208	" 208	1	1	0	0
224	" 224	1	1	0	1
240	" 240	1	1	1	0
256	" 256	1	1	1	1

0	2	0	CLSI				ZTNZ	ZTNX
							1	0

CLSI is effective from ROM edition No. 07.

- CLSI 1: Servo position LSI is not checked.
 0: Servo position LSI is checked.
- ZTNZ, ZTNX Reference point return function of X axis, Z axis in order.
 1: Reference point return function.
 0: No reference point return function.

0	2	4	PML2	PML1	DLME	RDAL				FMT
			7	6	5	4	3	2	1	0

- PML2, 1 Magnifications of pitch error compensation.
 The compensation amount multiplied by this magnification is used.

PML2	PML1	Magnifications
0	0	x 1
0	1	x 2
1	0	x 4
1	1	x 8

(Common for all axes)

- DLME 1: When store a program to the memory, all stored programs are canceled automatically.
 0: When store a program to the memory, all stored programs are not canceled automatically.
- RDAL 1: When store a program to the memory, all programs always are stored.
 0: When store a program to the memory, whether one program is stored or all programs are stored is selected by operation of MDI.

(All the programs is stored by)

- FMT 1: Performs software parity check as regards part program editing areas.
 0: Does not perform.
 This parameter is set to 1 automatically, when the condition has become ready for checking. This parameter cannot be turned on/off externally. In editions 07 or earlier, this parameter must always be 0.

0	2	6		FHDL	NGMP	CFFVY				CKIM	
				7	6	5	4	3	2	1	0

- FHDL 1: Movement amount per scale of manual pulse generator is fixed to 0.01 mm/0.001 inch and is not influenced by signals of MP1.
 0: Movement amount per scale of manual pulse generator varies according to MP1.
- NGMP 1 pulse feed amount of MPG is as below.

MGMP	MP2	MP1	Movement distance
0	0	0	0.001 mm/0.0001 inch
0	0	1	0.01 mm/0.001 inch
0	1	0	0.1 mm/0.01 inch
1	0	0	0.01 mm/0.001 inch
1	0	1	0.001 mm/0.0001 inch
1	1	0	0.1 mm/0.01 inch

- OFFVY 1: Even VRDY signal is on before sending PRDY signal, it is not alarm.
 0: When VRDY signal is on before sending PRDY signal, it is alarm.

- CKIM 1: Ignores the turning on or off of the machine lock signal during automatic operation (keeps the same state when cycle start was applied).
 0: Makes the machine lock signal valid immediately.
 (The machine lock signal is always made valid in the manual mode.)

CKIM is effective from ROM edition No. 07.

	0	2	7
--	---	---	---

CMRX

	0	2	8
--	---	---	---

CMRZ

CMRX, CMRZ Command multiply for each axis.
 Refer to parameter No. 014, 015 about setting value.

Setting code	Multiply
1	0.5
2	1
4	2
10	5
20	10

Multiply is set 1 by other than these setting code.
 This parameter is set by decimal number.

Standard setting code is 2 for pulse coder, resolver, inductosyn

	0	3	1
--	---	---	---

VLOCX

	0	3	2
--	---	---	---

VLOCZ

VLOCX, VLOCZ Clamp of feed command value of X axis, Z axis in order.
 Setting amount 0 ~7 (VELO)

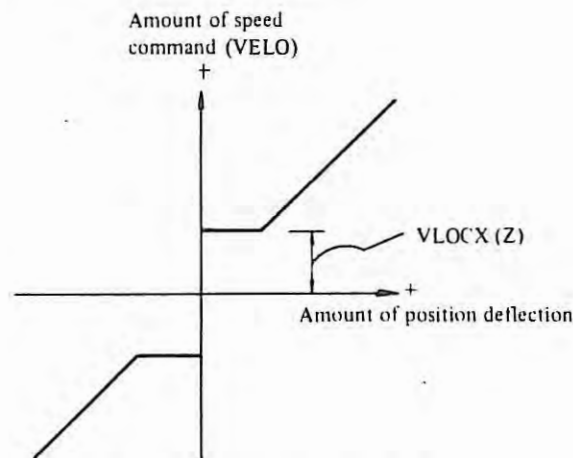

This value should usually be set to 0.

0	3	5
---	---	---

MBUF1

0	3	6
---	---	---

MBUF2

MBUF1, MBUF2 Up to two M codes which when read, cancel the inform in the fuffer are set.
Setting amount 00 ~ 97.

0	3	7
---	---	---

SPGST

SPGST Spindle motor speed at gear shifted.
Setting amount 0 ~ 255.
Setting value = $\frac{\text{Spindle motor speed at gear shifted.}}{\text{Max. spindle motor speed.}} \times 4095$

0	3	8
---	---	---

SPSOR

SPSOR Spindle speed (rpm) at spindle orientation. (For constant surface speed control).
Setting amount 0 ~ 255 (Unit: rpm)

0	4	0
---	---	---

EXOMAX

EXOMAX Allowable value at limit check in external tool offset B function. (not used)
Setting range 0 ~ 255
Setting unit 0.002 mm (Metric system)
0.0002 inch (Inch system)

0	4	1
---	---	---

EXOFS1

} }

0	5	6
---	---	---

EXOFS16

EXOFS1 ~ EXOFS16 Data multiplier for outside diameter measuring in external tool offset B function. (not used)
Setting range 0 ~ 15 (Unit 0.1)

Option.

0	5	7	TMHOR (Hour)
---	---	---	--------------

0	5	8	TMMIN (Minute)
---	---	---	----------------

0	5	9	TMSEC (Second)
---	---	---	----------------

TMHOR Run hour display per hour 0 ~ 255 (unit: 1 hour)
TMMIN Run hour display per minute 0 ~ 59 (unit: 1 minute)
TMSEC Run hour display per second 0 ~ 58 (unit: 2 seconds)

This parameter can be preset by setting operation.

0	6	2	SCTTIM
---	---	---	--------

Setting for delay timer in checking the spindle speed arrival signal.
 Set the term from S function is performed to start the check the spindle speed arrival signal.
 Setting amount: 0 ~ 255 (unit msec)

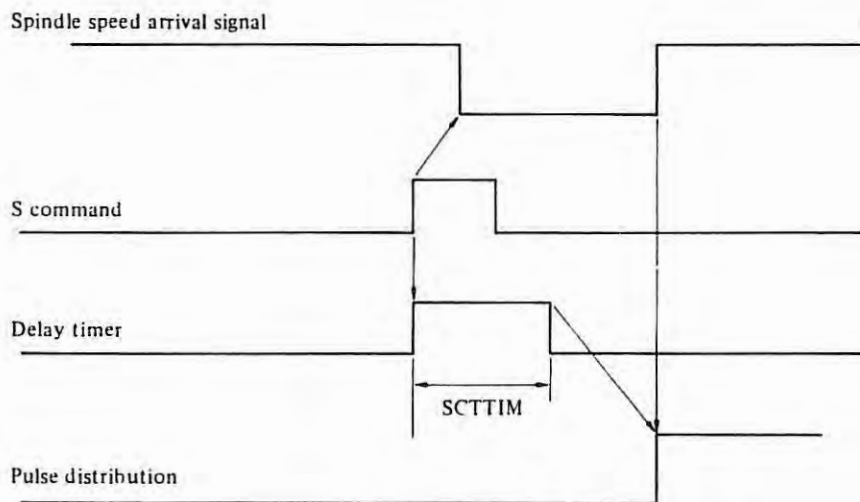

0	6	4	THDCH
---	---	---	-------

THDCH Width of chamfering for thread cutting.
 Setting amount 0 ~ 127 (Unit: 0.1 pitch)
This value can be set through MDI panel (Address SET).

Thread cutting cycle (G92)

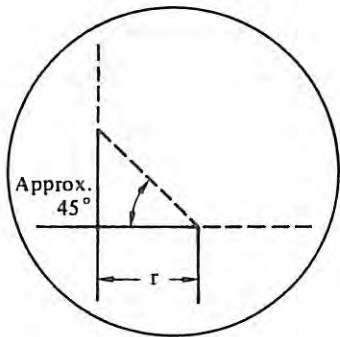
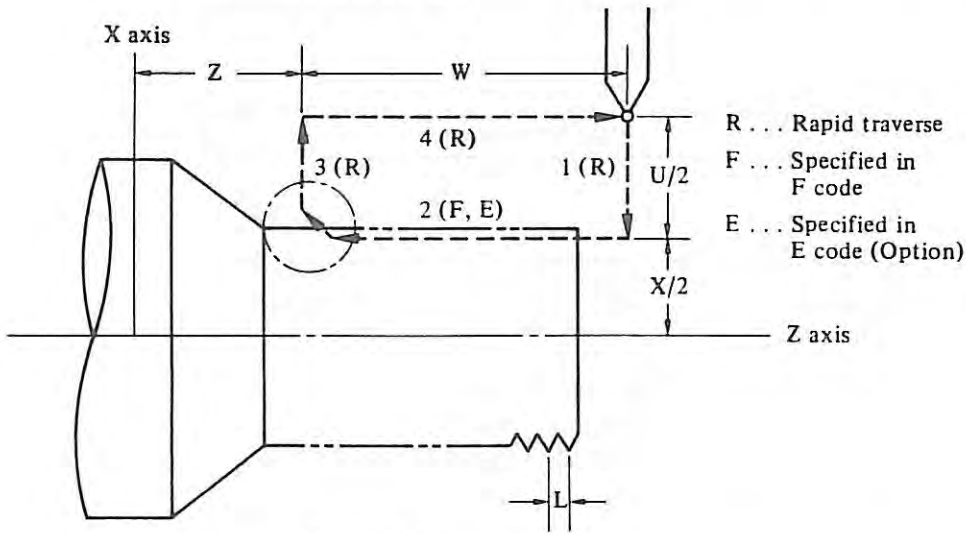

(The chamfered angle in the left figure is 45 degrees or less because of the delay in the servo system)

Detailed chamfered thread

Thread cutting cycle (G76)

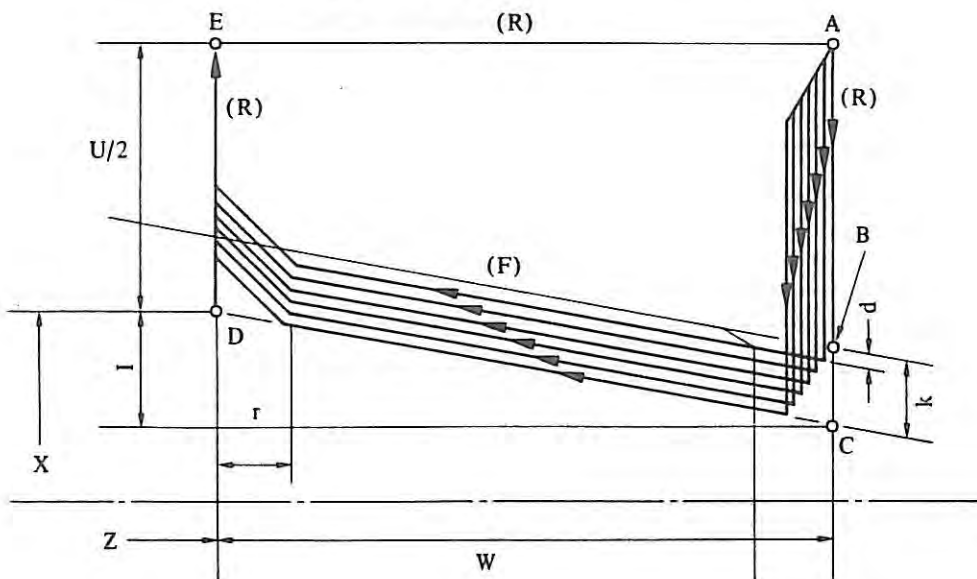

0	6	5
---	---	---

GROVE

GROVE Return amount at G74, G75
 Setting amount mm input 0 ~ 16383 (Unit: 0.001 mm)
 inch input 0 ~ 16383 (Unit: 0.0001 inch)
 This value can be set through MDI panel (Address SET).

Grooving cycle (G75)

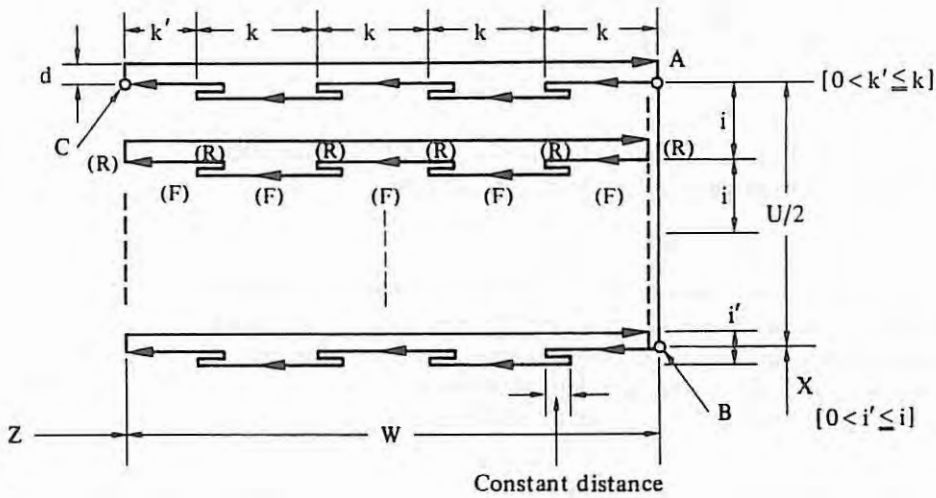
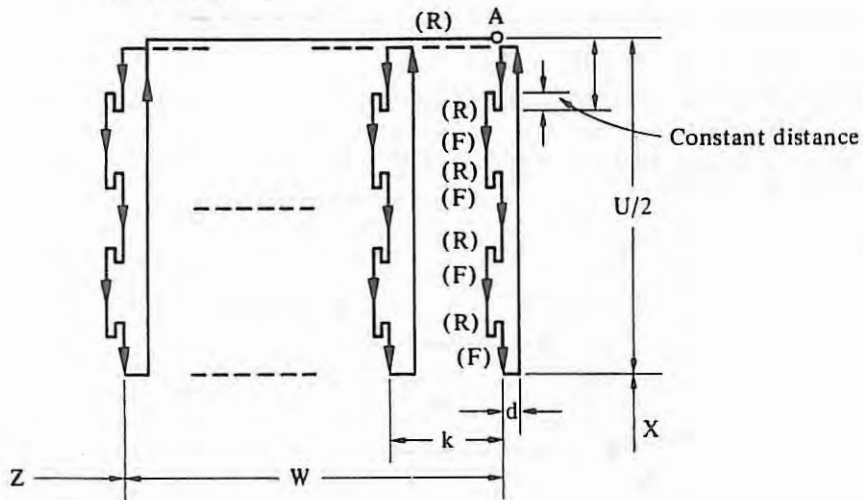

0	6	6
---	---	---

THDFN

THDFN Finishing allowance at G76.
 Setting amount mm input 0 ~ 16383 (Unit: 0.001 mm) (radius designation)
 inch input 0 ~ 16383 (Unit: 0.0001 inch)
 The value can be set through MDI panel (Address SET).
 (Refer to parameter 68)

0	6	7
---	---	---

MRCDT

MRCDT Escaping amount at multiple repetitive cycle G71, G72.
 Setting amount mm input 0 ~ 16383 (Unit: 0.001 mm) (radius designation)
 inch input 0 ~ 16383 (Unit: 0.0001 inch)

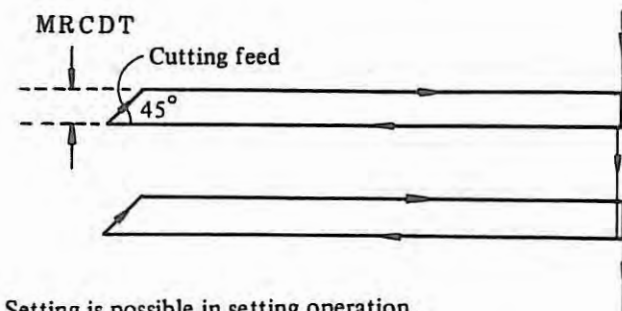

Setting is possible in setting operation.

0	6	8
---	---	---

THCLM

THCLM Minimum cutting depth at thread cutting cycle G76.
Setting amount mm input 0 ~ 16383 (Unit: 0.001 mm)
inch input 0 ~ 16383 (Unit: 0.0001 inch)
This value can be set through MDI panel (Address SET).

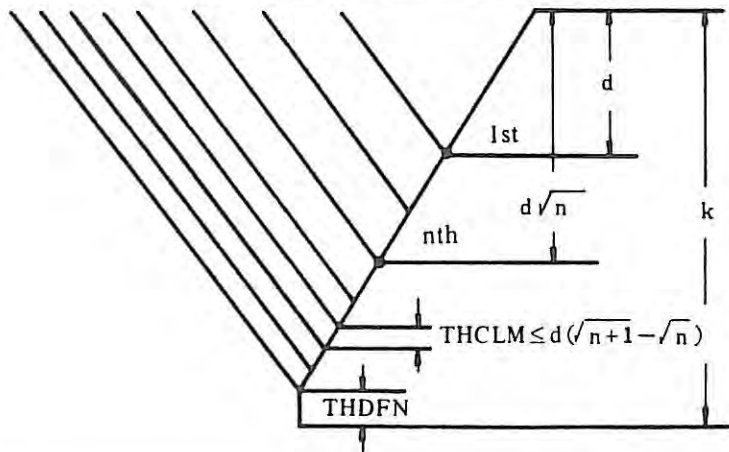

If the calculated value by formula $d(\sqrt{n+1} - \sqrt{n})$ is smaller than THCLM value, cutting amount is clamped at THCLM value.

0	6	9
---	---	---

CRCDL

CRCDL When tool moves along the outside of acute angle close to 90° at tool nose radius compensation, limitations on ignoring a small movement amount.
Setting amount mm input 0 ~ 16383 (Unit: 0.001 mm)
inch input 0 ~ 16383 (Unit: 0.0001 inch)

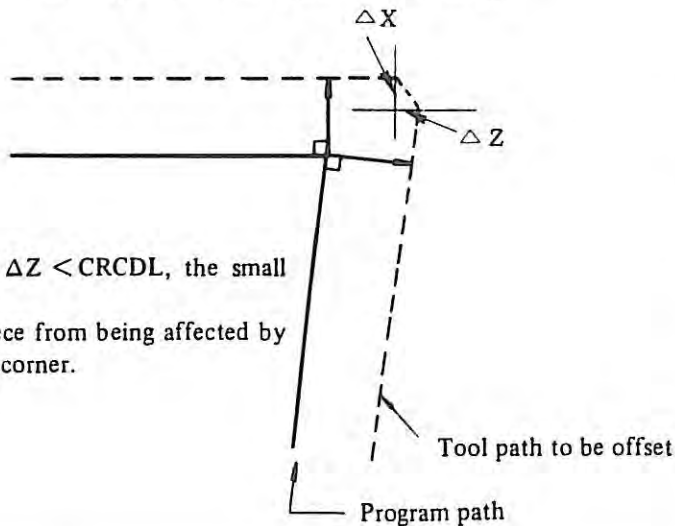

If $\Delta X < CRCDL$ and $\Delta Z < CRCDL$, the small movement is ignored.
It prevents the workpiece from being affected by stopping the tool at the corner.

0	7	0
---	---	---

INPX

0	7	1
---	---	---

INPZ

INPX, INPZ Width of X axis, Z axis in-position in order.
Setting amount 0 ~ 32767 (Detect unit)
Standard setting 10

Refer to parameter No. 006 "CINP"

0	7	4
---	---	---

STPEX

This parameter is related to alarm No. 410, 420.

0	7	5
---	---	---

STPEZ

STPEX, STPEZ

Limitation value of position deviation amount at stoppage.
STPEX for X-axis and STPEZ for Z axis.
Setting amount 0 ~ 32767 (Detect unit)
Standard setting 500

0	7	8
---	---	---

SERRX

This parameter is related to alarm No. 410, 421.

0	7	9
---	---	---

SERRZ

SERRX, SERRZ

Limitation value of position deviation amount during movement.
SERRX for X axis and SERRZ for Z axis.
Setting amount 0 ~ 32767 (Detect unit)

$$SERRX, Z = 1.2 \times \frac{\text{rapid traverse feed rate (m/min)}}{60 \times \alpha \text{ (mm)}} \times \frac{10^3}{\text{servoloop gain (sec}^{-1}\text{)}}$$

α : Detect unit standard: X axis 0.0005 mm, Z axis 0.001 mm
Servo loop gain standard: 30 sec⁻¹ (parameter number 90)

0	8	2
---	---	---

GRDSX

0	8	3
---	---	---

GRDSZ

GRDSX, GRDSZ

Setting of grid shift amount of X axis, Z axis in order.
Setting amount 0 ~ ±32768 (Detect unit)
When the reference point is shifted, the sign of this parameter is necessary.
When grid shift amount is zero, data should be set same as capacity of reference counter.

Refer to Parameter 14, 15

(1) Grid system

The machine tool moves at the rapid traverse rate and executes the reference return sequence when ZRN is turned ON and the JOG button is pressed after setting the mode select switch to the JOG mode. The JOG button must be depressed until the reference return is completed, otherwise the machine will stop. As the moving member of the machine approaches the reference point and reaches the point to decelerate, the deceleration command signal (*DCX, *DCZ) must be turned ON (to open the contact). (to close the contact). The feed stops on the reference point, when grid signal (ZD a) is turned on. Thus the return is completed and the reference return signal (ZP a) is output from NC. However, the reference return can be completed without grid signal, that is, the feed stops on the 1st scale after the deceleration command signal (*DCα) is turned off. Scale after the deceleration command signal (*DCα) is turned off. The machine cannot be moved manually once it completes the reference return and no axes can be moved by any command if ZRN is turned off.

Setting value must be within contents of reference counter.

(2) **Magnetic switching system**

In this case, the operation is the same as grid system, however, there are three differences, that the feed is stopped by the rise of the signal $ZD\alpha$ (α : X or Z), the reference point return can not be completed without $ZD\alpha$. Completion can not be checked by G27 command.

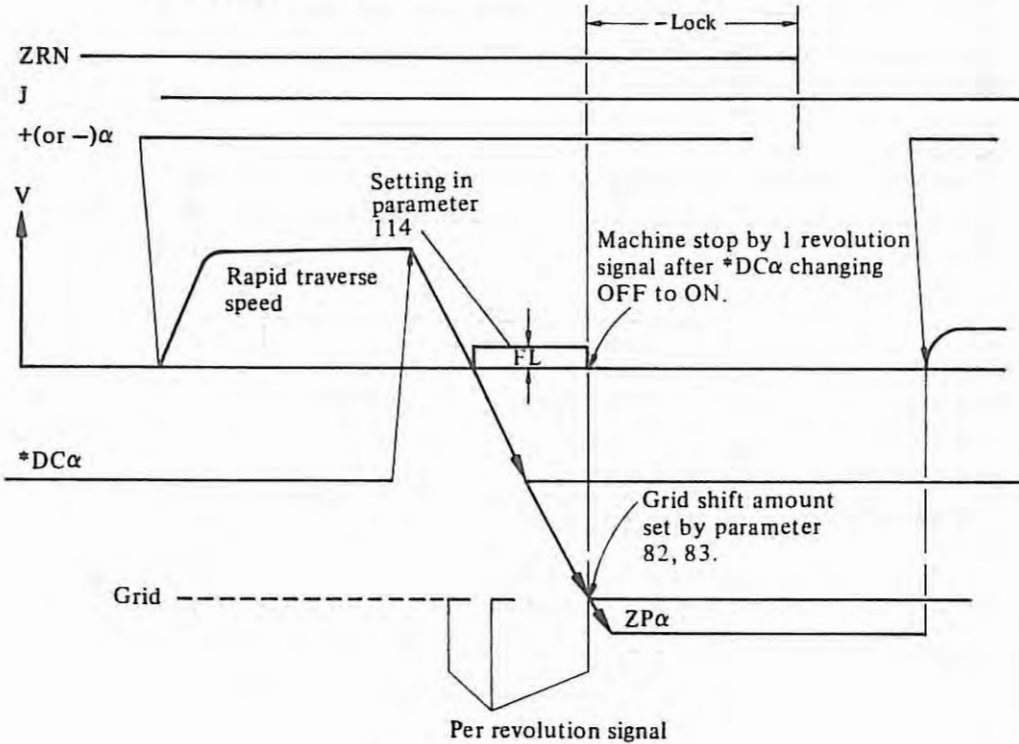

Time chart (Grid system)
In case of α Axis (α : X or Z)

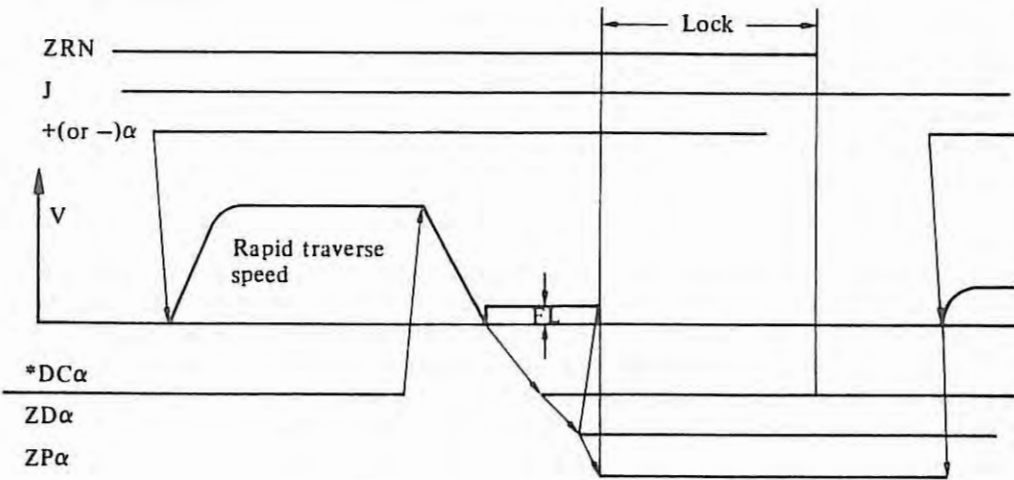

Time chart (Magnetic switching system)
In case of α axis (α : X or Z)

	0	8	6
--	---	---	---

LPGMX		
-------	--	--

	0	8	7
--	---	---	---

LPGMZ		
-------	--	--

LPGMX, LPGMZ Setting of servo loop gain multiplier of X axis, Z axis.

$$\text{Setting amount} = 2048 \times \frac{E}{L} \times \alpha \times 1000$$

$$E = \begin{cases} 7 \text{ [v]} & \text{(For motor with 7V at 1000 rpm)} \\ & \text{(DC motor model 10, 20, 30, 20H, 30H)} \\ 3.5 \text{ [v]} & \text{(For motor with 7V at 2000 rpm)} \\ & \text{(DC motor model 0, 5)} \end{cases}$$

L: Machine movement amount per motor revolution (mm or inch)

α : Detect unit (mm or inch)

(Example) 2mm per motor revolution at 1000 rpm/7V

$$\text{Setting value: } 2048 \times \frac{7}{2} \times 0.0005 \times 1000 = 3584$$

(At detect unit 0.0005 mm)

Machine feed amount per one motor rotation	Axis	Loop gain multiplier	
		7V/1000 rpm servo motor (DC motor model 10, 20, 30, 20H, 30H)	7V/2000 rpm servo motor (DC motor model 0, 5)
10mm, 10 deg.	X	1434	717
	Z		
8mm, 8 deg.	X	1792	896
	Z		
6mm, 6 deg.	X	2389	1195
	Z		
5mm, 5 deg.	X	2867/1434	1434/717
	Z	2867	1434
4mm, 4 deg.	X	3584/1792	1792/896
	Z	3584	792
3mm, 3 deg.	X	4779/2389	2389/1195
	Z	4779	2389
2mm, 2 deg.	X	7168/3584	3584/1792
	Z	7168	3584
1mm, 1 deg.	X	7168/3584	3584/1792
	Z	3584	3584

In case X axis, left side data is used for radius programming and right side data is used for diameter programming. Above data are standard. Take care the limit of maximum feed rate in changing the DMR, CMR.

Machine feed amount per one motor rotation	Axis	Loop gain multiplier	
		7V/1000 rpm servo motor (DC motor model 10, 20, 30, 20H, 30H)	7V/2000 rpm servo motor (DC model 0, 5)
0.5 inch	X	2867/1433	1434/717
	Z	2867	1434
0.4 inch	X	3584/1792	1792/896
	Z	3584	1792
0.3 inch	X	4779/2389	2389/1195
	Z	4779	2389
0.25 inch	X	5734/2867	2867/1437
	Z	2867	2867
0.2 inch	X	7168/3584	3584/1792
	Z	7168	3584
0.15 inch	X	4778	2389
	Z		
0.1 inch	X	7168	3584
	Z		

In case X axis, left side data is used for radius programming and right side data is used for diameter programming. Above data are standard. Take care the limit of maximum feed rate in changing the DMR, CMR.

0	9	0	LPGIN
---	---	---	-------

LPGIN Setting of servo loop gain
 Setting amount 1 ~ 9999 (Unit: 0.01 sec⁻¹)
 Standard setting 3000

0	9	1	JOGF
---	---	---	------

JOGF JOG feed rate at rotary switch position 10.
 Setting amount 1 ~ 150 Unit: mm/min. (mm output)
 1 ~ 60 Unit: 0.1 inch/mm (inch output)

(Example) Set 20mm/min to parameter No. 91.

Position	Feed rate override	Manual	
		MM	INCH
0	0%	0mm/min.	0 in/min.
1	10	1.0	0.02
2	20	1.4	0.03
3	30	2.0	0.04
4	40	2.7	0.06
5	50	3.7	0.08
6	60	5.2	0.10
7	70	7.2	0.14
8	80	10	0.2
9	90	14	0.3
10	100	20	0.4
11	110	27	0.6
12	120	37	0.8
13	130	52	1.0
14	140	72	1.4
15	150	100	2
16	160	140	3
17	170	200	4
18	180	270	6
19	190	370	8
20	200	520	10
21	0	720	14
22	0	1000	20
23	0	1400	30
24	0	2000	40

Note: 1. The feed rate mentioned above is 20 mm/min by geometric series at override signal 100%. By setting the feed rate at the override 100% by a parameter, feed rates other than that in the table are obtained.
 2. The velocity error is ±3% in this table.

0	9	2
---	---	---

 RPDFX

0	9	3
---	---	---

 RPDFZ

RPDFX, RPDFZ Rapid traverse rate of X axis, Z axis in order.
Setting amount 30 ~ 15000 Unit: mm/min (mm output)
30 ~ 6000 Unit: 0.1 inch/min (inch output)

0	9	6
---	---	---

 LINTX

0	9	7
---	---	---

 LINTZ

LINTX, LINTZ The time constant value of linear acceleration/deceleration of X axis,
Z axis. (for rapid traverse)
Setting amount 8 ~ 4000 (Unit: m sec.)

1	0	0
---	---	---

 EXPTX

1	0	1
---	---	---

 EXPTZ

EXPTX, EXPTY Time constant of exponential acceleration deceleration for X axis
and Z axis at manual feed.
Setting amount 1 ~ 4000 (Unit: msec.)

1	0	4
---	---	---

 THRDT

THRDT The time constant value of X axis in thread cutting
Setting amount 1 ~ 4000. (Unit: m sec.)
The most suitable value can be set with this parameter and THDFL (para-
meter number 107).

1	0	5
---	---	---

 FEEDT

FEEDT Exponential type acceleration/deceleration time constant for feed.
Setting amount 8 ~ 4000 (Unit: msec.)

1	0	6
---	---	---

 FEDMX

THRDT Upper speed of cutting feed (Available for all axes)
Setting amount 6 ~ 15000 Unit: mm/min (metric output)
6 ~ 6000 Unit: 0.1 inch/min (inch output)

	1	0	7
--	---	---	---

THDFL

THDFL The lower limit value of X axis acceleration/deceleration in thread cutting (FL).

Setting amount 6 ~ 15000 Unit: mm/min (metric output)
6 ~ 6000 Unit: 0.1 inch/min (inch output)

Set 2000 mm/min to this parameter as standard.

The most suitable value can be set with this parameter and THRDT (parameter number 104).

(1) Without chamfering

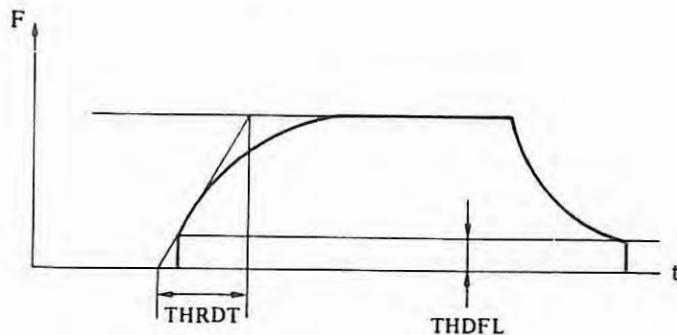

(2) With chamfering

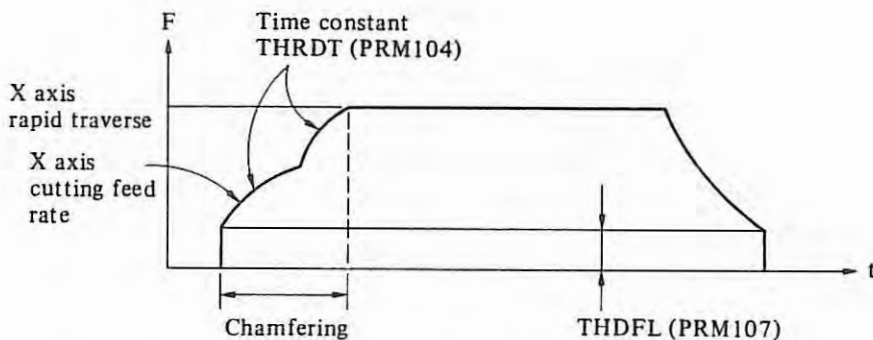

	1	0	8
--	---	---	---

FEDFL

FEDFL Low limit feed rate at acceleration/deceleration in cutting feed.

Setting amount 6 ~ 15000 unit: mm/min (mm output)
6 ~ 6000 unit: 0.1 inch/min (inch output)

Set '0' in normally.

	1	0	9
--	---	---	---

JGFLX

	1	1	0
--	---	---	---

JGFLZ

JGFLX, JGFLZ Low speed speed (FL) after deceleration in JOG feed for X axis and Z axis.

Setting amount 6 ~ 15000 unit: mm/min (mm output)
6 ~ 6000 unit: 0.1 inch/min (inch output)

1	1	3
---	---	---

RPDFL

RPDFL Least speed of rapid traverse override (Fo) (Common to all axes)
Setting amount 6 ~ 15000 Unit: mm/min (metric output)
6 ~ 6000 Unit: 0.1 inch/min (inch output)

1	1	4
---	---	---

ZRNFL

ZRNFL Low feed speed at reference point return (FL) (Common to all axes)
Setting amount 6 ~ 15000 Unit: mm/min (metric output)
6 ~ 6000 Unit: 0.1 inch/min (inch output)

1	1	5
---	---	---

BK LX

1	1	6
---	---	---

BK LZ

BK LX, BDLZ Backlash amount of X axis, Z axis respectively
Setting amount 0 ~ 255 Unit: Least command increment (At diameter command X axis is diameter value.)

1	1	9
---	---	---

SPDLC

SPDLC Set spindle speed offset compensation value, that is, compensation value of zero offset of spindle speed command voltage.
Setting amount 0 ~ ±8191

1	2	0
---	---	---

GRMX1

1	2	1
---	---	---

GRMX2

1	2	2
---	---	---

GRMX3

1	2	3
---	---	---

GRMX4

GRMX1 ~ GRMX4 Spindle speed corresponding with gear 1 ~ 4 when spindle speed command is 10V. (Only with constant surface speed control option)
Setting amount 1 ~ 32767 (Unit: RPM)

- 1) When same least spindle revolution number is used for common gear GR1 ~ 4
(Parameter 307 5th bit SLOW = 1)

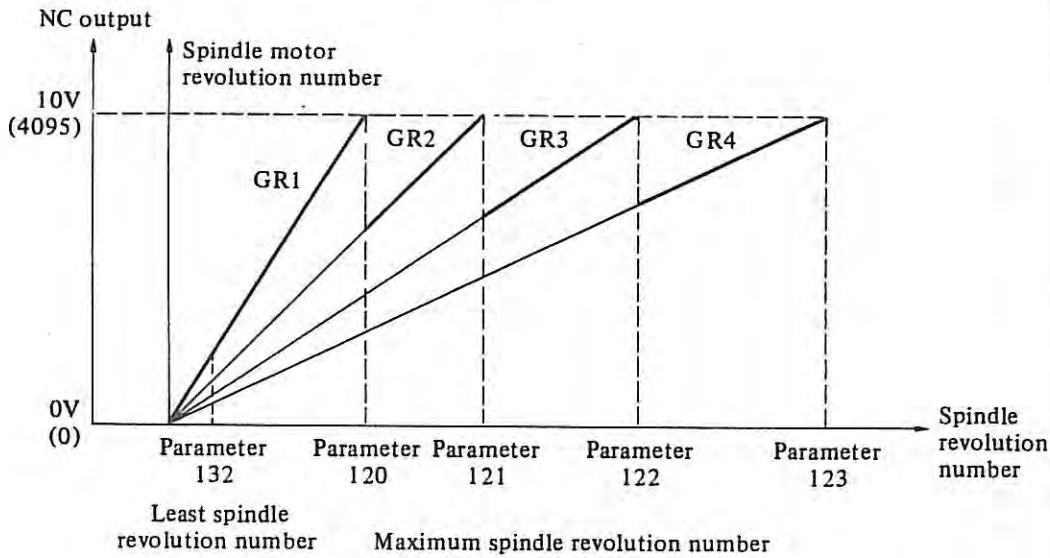

- 2) When different least spindle revolution number is used for different gear GR1 ~ 4
(Parameter 307 5th bit SLOW = 0)

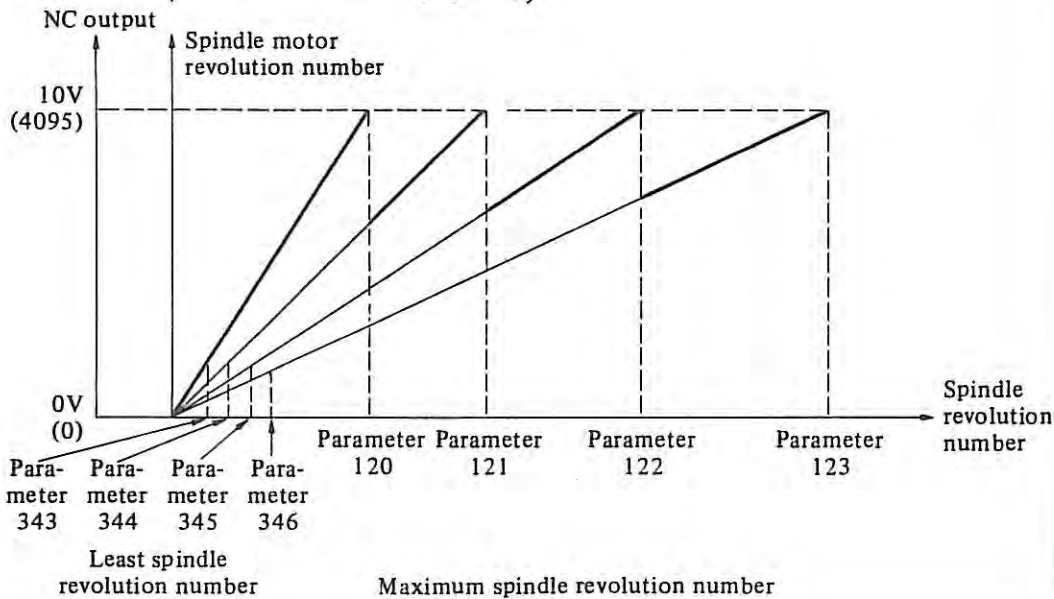

1	2	4	DRFTX
---	---	---	-------

1	2	5	DRFTZ
---	---	---	-------

DRFTX, DRFTZ Compensation amount of drift generated in servo loop of X axis, Z axis.
 Setting amount 0 ~ ±499 unit
 In case of automatic compensation, this amount is changed automatically.
 When on site-adjustment, set this parameter to '0' and set parameter 006 ADFT to 1.
 If drift compensation amount exceeds 500, alarm No. 412 or 422 is displayed.

Refer to parameter No. 006.
 In case set 1 to "ADFT".

	1	2	8
--	---	---	---

PHAZX

	1	2	9
--	---	---	---

PHAZZ

PHAZX, PHAZZ Servo phase shift amount of X axis, Z axis, respectively.
 Data corresponding with the phase of signal returning from feedback is automatically set (For Resolver/inductosyn)
 Setting amount: 0 ~ 500

	1	3	2
--	---	---	---

LOWSP

LOWSP Least spindle revolution number in constant surface speed control mode (G96).
 Setting amount 0 ~ 9999 (Unit: rpm)

	1	3	3
--	---	---	---

ACALFL

ACALFL Setting of measuring feedrate with automatic tool offset option
 Setting amount: 6 ~ 15000 mm/min
 6 ~ 6000 inch/min

	1	4	0
--	---	---	---

PSANGN

PSANGN Data of adjustment for gain in spindle analog output.
 Set the data of adjustment for gain in spindle analog output data 1000 is set normally.
 Setting amount: 700 ~ 1250
 Standard amount: 1000

[Adjustment method]

- (1) Set standard value "1000".
- (2) Command maximum value in S analog code.
- (3) Measure output voltage.
- (4) Reset PASNGN according to below formula.

$$\frac{10.00}{\text{Measuring Voltage}} \times 1000 = \text{Setting Value}$$

[Ex] In case measuring voltage is 9.7V.

$$\frac{10.00}{9.7} \times 1000 = 1031 \text{ (Parameter Value)}$$

- (5) After setting new data, check whether output voltage is maximum voltage (10V).

	1	4	1
--	---	---	---

TIME1

TIME1 Preset time for use.
 Setting amount 0 ~ 32767 (Unit: 0.1 H)
 This value can be set through MDI panel (Address SET).

	1	4	2
--	---	---	---

TIME2

TIME2 Preset time for use.
 Setting amount 0 ~ 99999999 (Unit: 0.1 H)

This is effective from ROM edition No. 4

Refer to parameter 057 ~ 059.

Refer to parameter 057 ~ 059.

	1	4	3	LT1X1
	1	4	4	LT1Z1
	1	4	7	LT1X2
	1	4	8	LT1Z2
	1	5	1	LT2X1
	1	5	2	LT2Z1
	1	5	3	LT2X2
	1	5	4	LT2Z2
	1	5	5	LT3X1
	1	5	6	LT3Z1
	1	5	7	LT3X2
	1	5	8	LT3Z2

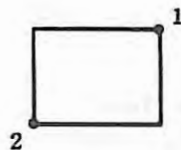
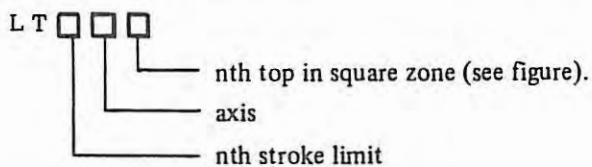

Set stroke limit mentioned above.
Setting amount 0 ~ ±99999999 (Unit: 0.001 mm or 0.0001 inch)
Parameters of the parameter number 151 through 158 can be set through MDI panel (Address SET).
In case of diameter command, X axis is set by diameter amount.

	1	5	9	REF2X
	1	6	0	REF2Z

BEF2X, REF2Z Distance from second reference point to first reference point of X axis, Z axis.
Setting amount 0 ~ ±99999999 (Unit: 0.001 mm or 0.0001 inch)
In case of diameter command, X axis is set by diameter amount.

	1	6	3	GANMAX
	1	6	4	GANMAZ

GANMAX, GANMAZ The value γ for X axis or Z axis in automatic tool offset
Setting amount 1 ~ 99999999 unit 0.001 mm (metric output)
1 ~ 99999999 unit 0.0001 inch (inch output)

Note 1) X axis is set by radius amount.
Note 2) Set data that is larger than parameter 165, 166.

1	6	5	EPCX
---	---	---	------

1	6	6	EPCZ
---	---	---	------

EPCS, EPCZ The value ϵ for X axis or Z axis in automatic tool offset.
 Setting amount 1 ~ 99999999 unit 0.001 mm (metric output)
 1 ~ 99999999 unit 0.0001 inch (inch output)

Note) X axis is set by radius amount.

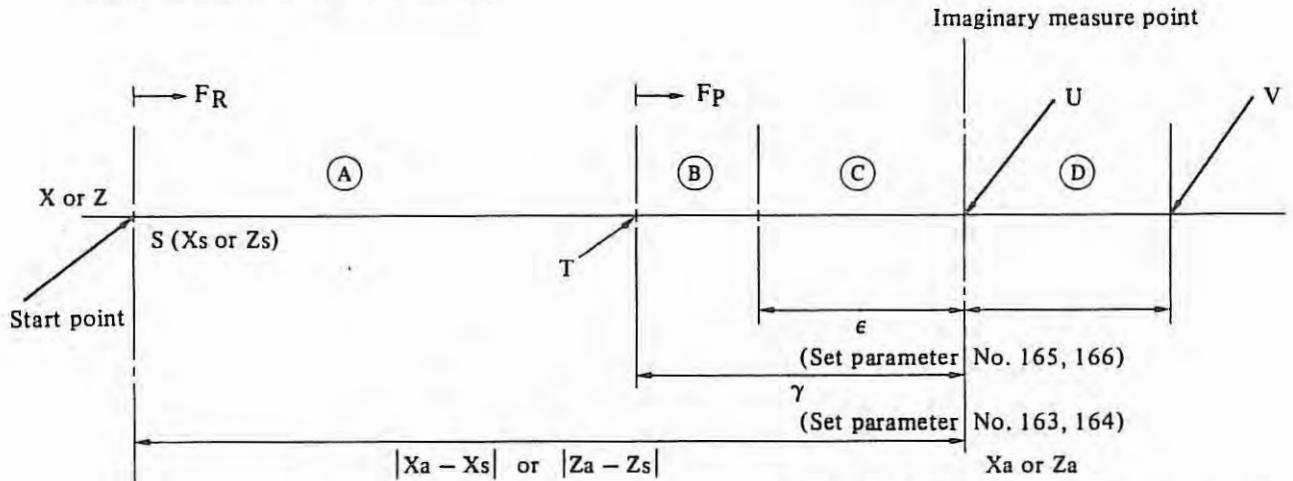

FR; rapid traverse speed
 Fp; measuring speed (set parameter No. 133)

When tool goes to imaginary measure point from start point by movement command (Xa or Za) in G34 or G35, it moves by rapid traverse in area (A). It stops at point T (Xa - γx or Za - γz) and moves in area (B), (C) and (D).

If measuring point arrival signal goes on during movement in (B), (C) or (D), it stops immediately.

If measuring point arrival signal goes on except area (C) and (D) or does not go on until V point, alarm No. 80 is occurred.

3	0	6	SKPF				NEOP		TMCR	
			7	6	5	4	3	2	1	0

SKPF 1: On skip cutting command (G31), the feed rate comes to the FL speed set by parameter (No. 342)

0: On skip cutting command (G31), the feed rate follows F code.

NEOP 1: When registering a tape in memory, M02, M30 or M99 is not counted as the program end.

0: When registering a tape in memory, M02, M30 or M99 is counted as the program end.

TMCR 1: User macro is called by T code.

0: No user macro is called by T code.

3	0	7	FCUT		SLOW				OTCS
---	---	---	------	--	------	--	--	--	------

FCUT 1: In the multiple repetitive cycle (G71, G72), finishing work of the final rough cutting is not executed.

0: In the multiple repetitive cycle (G72, G72), finishing work of the final rough cutting is executed.

- SLOW** 1: It sets the clamp value of the lowest speed in S4-digit binary 12 bit output/ analogue output for all gears in common. (parameter 132)
 0: It sets the clamp value of the lowest speed in S4-digit binary 12 bit output/ analogue output individually for each gear. (parameter 343, 344, 345, 346).
- OTCS** 1: When the movable member of machine touches a mechanical limit switch, the machine stops instantaneously.
 0: When the movable member of machine touches a mechanical limit switch, the machine stops after deceleration.

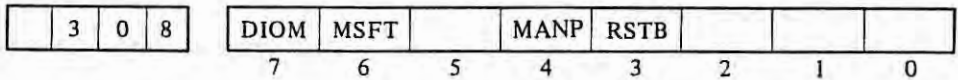

- DIOM** 1: It is possible to read and write DI, DO by a macro variable.
 0: It is not possible to read and write DI, DO by a macro variable.
- MSFT** 1: When the option of user macro is equipped with, on key-input from MDI, the shift key is valid.
 0: On key-input from MDI, the shift key is invalid.
- MANP** 1: When there is no decimal point in argument of user macro, the argument is regarded as integer. (Not used)
 0: When there is no decimal point in argument of user macro, the argument is regarded as value with decimal point obeyed the regulations.
- RSTB** 1: On resetting by an emergency stop, external reset, or reset & wind, no resetting signal is issued during the reset.
 0: Also on resetting by an emergency stop, external reset or reset & wind, resetting signal is issued during the reset.

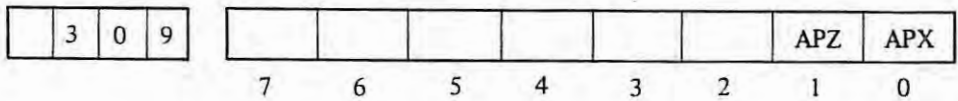

- APX, APZ** Automatic coordinate system setting (option) for X axis and Z axis is effective or ineffective in order.
 1: Automatic coordinate system setting is effective.
 0: Automatic coordinate system setting is ineffective.

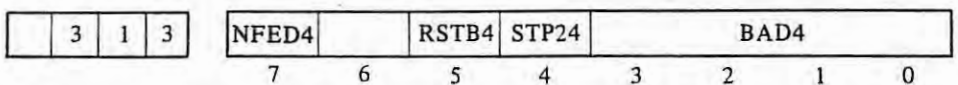
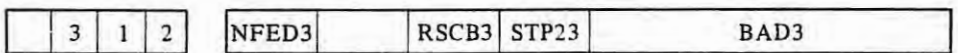
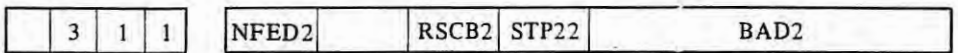
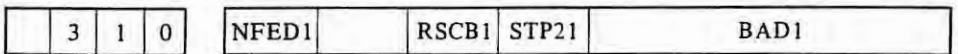

- RSCB 1, 2, 3, 4** Whether control codes (DC1 ~ DC4) are used or not on I/O devices 1, 2, 3, and 4 in order.
 1: The control codes are not used.
 0: The control codes are used.
- STP21, 2, 3, 4** In order of I/O devices 1, 2, 3 and 4, the stop bit is to be 2 bits/1 bit.
 1: The stop bit is to be 2 bits.
 0: The stop bit is to be 1 bit.
- BAD1, 2, 3, 4** In order of I/O devices 1, 2, 3 and 4, it sets a baud rate.

Refer to parameter 340, 341.

NFED 1, 2, 3, 4 In order of I/O device 1, 2, 3 and 4, feed is executed or not.
 1: Executed
 0: Not executed

Baud rate	BAD1, 2, 3, 4			
50	0	0	0	0
100	0	0	0	1
110	0	0	1	0
150	0	0	1	1
200	0	1	0	0
300	0	1	0	1
600	0	1	1	0
1200	0	1	1	1
2400	1	0	0	0
4800	1	0	0	1
9600	1	0	1	0

Note 1. Refer to parameters 340, 341.

Note 2. Parameter number 313 is used for data transmission between NC and robot with robot control option.

3	1	5	FCSS							
			7	6	5	4	3	2	1	0

FCSS 1: S analog voltage output is changed at intervals of 8ms (new specification).
 0: S analog voltage output is changed at intervals of 64ms (old specification).

FCSS is effective from ROM edition No. 09.

3	1	6	CDCSG	PCFBK					DSCGX	DSCGZ
			7	6	5	4	3	2	1	0

CDCSG 1: It carries out no frequency check of DSCG feedback.
 0: It carries out frequency check of DSCG feedback.
 (After field adjustment, this parameter should be always set to "0".)

PCFBK 1: Servo feedback check is performed.
 0: Servo feedback check is not performed.
 (Refer to parameter No. 363, 364.)

PCFBK is effective from ROM edition No. 09.

DSCGX, Z In order, it sets the type of position detection system of X axis, Z axis.
 1: Resolver or inductosyn
 0: Pulse coder

3	1	7	UM#8	UM#7	UM#6	UM#5	UM#4	UM#3	UM#2	UM#1
			7	6	5	4	3	2	1	0

UM#1 ~ 8 On EIA code, it registers a code corresponding to "#" used in user macro.
 Example: UM#8 ~ UM#1 = 01001001
 The code that has a hole in channels 1, 4, and 7 is counted as "#" of EIA code. (If all zero set to this parameter, "#" is not used.)

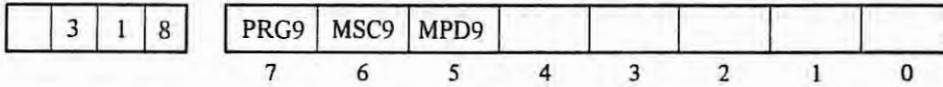

- PRG9** 1: Program number 9000 ~ 9899 can not be edited.
 0: Program number 9000 ~ 9899 can be edited.
- MSC9** 1: If the mode is single block mode during execution of program numbers 9000 ~ 9899, single block stop is effective in excuting macro format of user macro.
 0: Even if the mode is single block mode during execution of program numbers 9000 ~ 9899, single block stop is ineffective in excuting macro format of user macro.
- MPD9** 1: The contents of the program is not displayed during execution of program numbers 9000 ~ 9899.
 0: The contents of the program is displayed during execution of program numbers 9000 ~ 9899.

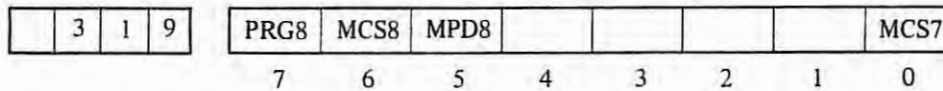

These can also be set as setting parameter.

- PRG8** 1: Program Nos. 8000 ~ 8999 can not be edited.
 0: Program Nos. 8000 ~ 8999 can also be edited.
- MCS8** 1: If the mode is single block mode during execution of program numbers 8000 ~ 8999, single block stop is effective in excuting macro format of user macro.
 0: Even if the mode is single block mode during execution of program numbers 8000 ~ 8999, single block stop is ineffective in excuting macro format of user macro.
- MPD8** 1: The contents of the program is not displayed during execution of program numbers 8000 ~ 8999.
 0: The contents of the program is displayed during execution of program numbers 8000 ~ 8999.
- MCS7** 1: If the mode is single block mode during execution of program numbers 0001 ~ 7999, single block stop is effective in excuting macro format of user macro.
 0: Even if the mode is single block mode during execution of program numbers 0001 ~ 7999, single block stop is ineffective in excuting macro format of user macro.

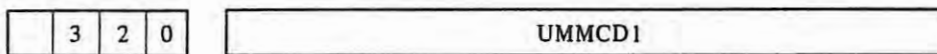

UMMCD1, 2, 3 It sets up to 3 M codes to call user macro.
 Setting amount 01 ~ 97
 (With M00 the user macro can not be called. Even when 00 are set, it is equivalent to no setting.)

	3	2	3		UMGCD0
--	---	---	---	--	--------

	3	2	4		UMGCD1
--	---	---	---	--	--------

	3	2	5		UMGCD2
--	---	---	---	--	--------

	3	2	6		UMGCD3
--	---	---	---	--	--------

	3	2	7		UMGCD4
--	---	---	---	--	--------

	3	2	8		UMGCD5
--	---	---	---	--	--------

	3	2	9		UMGCD6
--	---	---	---	--	--------

	3	3	0		UMGCD7
--	---	---	---	--	--------

	3	3	1		UMGCD8
--	---	---	---	--	--------

	3	3	2		UMGCD9
--	---	---	---	--	--------

UMGCD0, 1, . . . , 9 It sets up to 10 G codes to call user macro.
Setting amount 01 ~ 99.
(With G00, the user macro can not be called. Even when 00 are set, it is equivalent to no setting.)

	3	3	6		PECZR \bar{X}
--	---	---	---	--	-----------------

	3	3	7		PECZRZ
--	---	---	---	--	--------

PECZR \bar{X} , Z
Zero point setting on pitch error compensation data setting for X and Z axis
Setting amount 0 ~ 127
In this setting, the setting number of the machine zero point (reference point) is set on pitch error compensation data setting.

Refer to Parameter
1000 ~

3	4	0
---	---	---

IDVICE

IDVICE It selects an input device on registering a program in memory. (When INPUT DEVICE 2 = 1 (RS232C) of setting has been set, this setting becomes valid.)

Set value	
1	ASR33/43 (parameter such as a baud rate, etc. should be set to parameter No. 310.)
2	RS232C (parameter such as a baud rate, etc. should be set to parameter No. 311.)
3	RS232C (parameter such as a baud rate, etc. should be set to parameter No. 312.)
4	RS232C (parameter such as a baud rate, etc. should be set to parameter No. 313. Also used for data transfer when Robot interface option is provided.)

3	4	1
---	---	---

ODVICE

ODVICE It selects an output device on punching out.

Set value	
0	FACIT PUNCHER
1	ASR33/ASR43 (parameters such as a baud rate, etc. should be set to parameter No. 310.)
2	RS232C (parameters such as a baud rate, etc. should be set to parameter No. 311.)
3	RS232C (parameters such as a baud rate, etc. should be set to parameter No. 312.)
4	RS232C (parameters such as a baud rate, etc. should be set to parameter No. 313. Also used for data transfer when Robot interface option is provided.)

Above parameters can also be set as setting parameter.

3	4	2
---	---	---

PSKPFL

PSKPFL FL speed of skip cutting (common to all axes)
Setting amount 6 ~ 15000 Unit: 1 mm/min (mm output)
6 ~ 6000 Unit: 0.1 inch/min (inch output)

Refer to parameter
120 ~ 123.

3	4	3
---	---	---

 GRMIN1

3	4	4
---	---	---

 GRMIN2

3	4	5
---	---	---

 GRMIN3

3	4	6
---	---	---

 GRMIN4

GRMIN1, 2, 3, 4 The lowest spindle speed in the constant surface speed control to gears 1, 2, 3, 4 in order.
(For constant surface speed control option)
Setting amount 0 ~ 9999 Unit: rpm
This parameter is valid only when parameter 307-SLOW = 0.

3	6	3
---	---	---

 PCFBKX

3	6	4
---	---	---

 PCFBKZ

PCFBKX/Z Amount of movement when servo feedback check is performed in X/Z, respectively.
Setting 0 to $\pm 32,767$; detection unit

Note 1) When the setting is 0, servo feedback check is not performed.

Note 2) The amount of movement for servo feedback check is fixed at 0.255mm (0.0255 inch).

Note 3) The setting is a value whereby the machine can be moved. Therefore, use a small value as much as possible. However, note that setting too small a value will activate the alarm.

3	7	5
---	---	---

 PPRTMX

3	7	6
---	---	---

 PPRTMZ

PPRTMX, Z The coordinates for automatic coordinate system setting on mm input of X axis and Z axis in order.
It sets the distance from the zero point of the coordinate system to be set to the 1st reference point in the mm system.
Setting amount 0 ~ ± 99999999 Unit: 0.001 mm
When inch/metric conversion option is equipped with, parameter Nos. 379 ~ 380 should be also set.

	3	7	9
--	---	---	---

PPRTIX

	3	8	0
--	---	---	---

PPRTIZ

PPRTIX, Z The coordinates for automatic coordinate system setting on inch input of X axis and Z axis in order.

It sets the distance from the zero point of the coordinate system to be set to the 1st reference point in the inch system.

Setting amount 0 ~ 99999999 Unit: 0.0001 inch

When inch/metric conversion option is equipped with parameter, Nos. 376 ~ 376 should also be set.

	3	8	3
--	---	---	---

PECINTX

	3	8	4
--	---	---	---

PECINTZ

PECINTX, Z

Distance between two set point on pitch error compensation setting for each axes.

Setting amount 8000 ~ 20000000 (Unit: 0.001 mm)

4000 ~ 20000000 (Unit: 0.0001 inch)

(Maximum compensation distance = setting distance × 127)

	3	8	7
--	---	---	---

Secret number

Register a secret number to be locked in advance.

Setting range: 1 to 99,999,999

	4	0	8
--	---	---	---

Lock/Unlock

Entering the same number as that of parameter 387 effects unlocking. Entering a different number effects locking.

(Note 1) Whenever parameter 387 is zero, an unlocked state is provided. Turning off/on the NC power does not effect locking. Note that any number other than zero should not be set in parameter for programs not to be locked.

	1	0	0	0
--	---	---	---	---

Pitch error compensation amount

}

}

	2	1	2	7
--	---	---	---	---

Pitch error compensation amount

1000 ~ 1127	Pitch error compensation amount for X axis
2000 ~ 2127	Pitch error compensation amount for Z axis

Setting amount 0 ~ ±7

If -9999 is set, all the compensation for that axis become zero.

Note: Pitch error compensation becomes effective after completion of reference point return for each axis. Even if parameter setting for pitch error compensation is performed, the compensation does not become effective unless reference point return is performed.

These parameter setting must be done before completion of reference point return.

This parameter amount multiplied by compensation magnification (parameter 024) is actual compensation amount.

Refer to parameter 024, 336, 337, 383, 384.

Each distance of compensation point in pitch error compensation is same. Set that pitch for each axis. Compensation points are 128 points (0 ~ 127) in each axis.

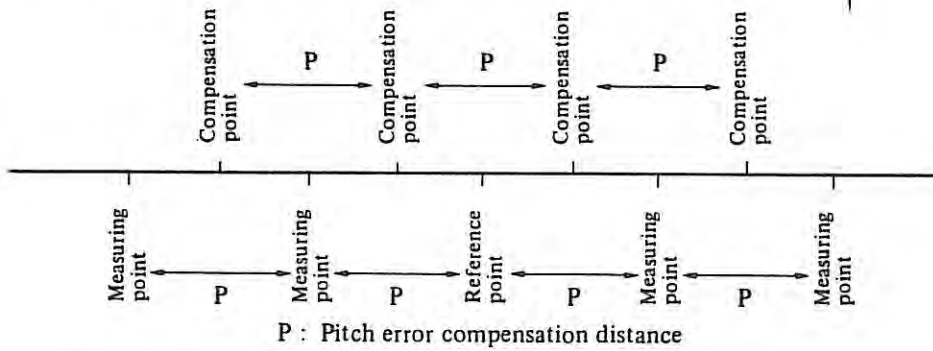

There to minimum limit in pitch error compensation distance.

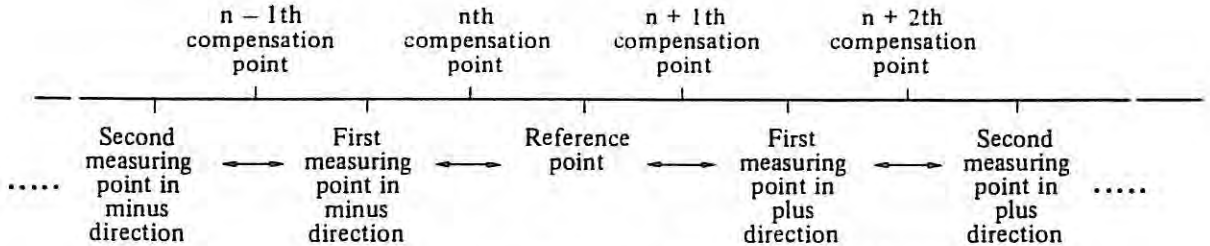

Measure the pitch error by every same distance of measuring point (parameter 383, 384) from reference to plus direction and set the error amount of first measuring point to the (n+1)th compensation point amount. The error amount of second measuring point, third measuring point . . . are set to n + 2, n + 3 . . . so on.

In minus direction, same as above procedure

In case sign of data is plus, the pitch error compensation is performed same direction to current movement direction.

If sign is minus, it is performed reverse direction to current movement direction.

For instance, if assumed 0 for pitch error zero point, the set point 1 is in position of +8.000 mm and the set point 127 is in position of +1016.000 mm. Thus, compensation can be made from 0 to the position of +1016.000 mm.

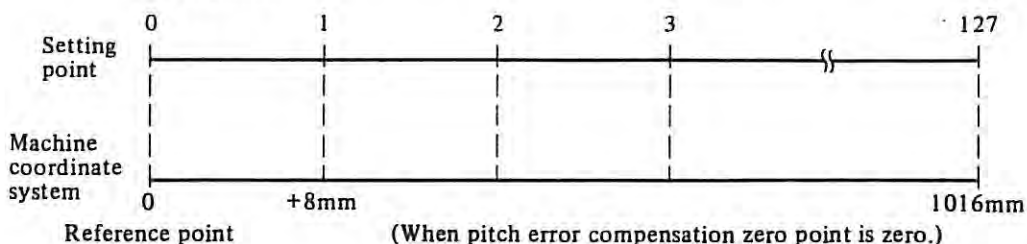

And, when pitch error compensation zero point is set to 60, 61st setting point is +8 mm position, setting zero point is -480 mm position, and 127th setting point is +536 mm position.

So, the compensation can be performed in the range from -480 to +536 mm.

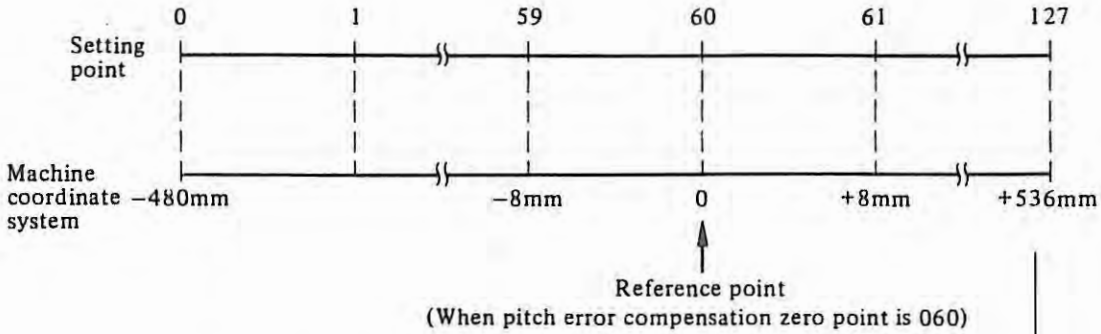

Pitch error zero point should be set according to the machine stroke and reference point. Parameter numbers 336 and 337 are used for these setting.

Ex. 1
Error on position

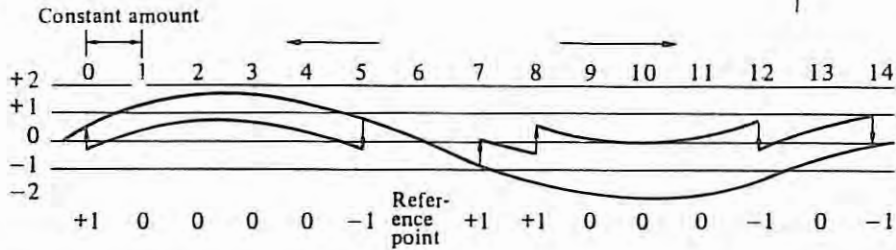

Pitch error compensation amount are set by increment amount. Sign means direction of compensation. When axis reach at compensation point in +direction.

- error means + compensation
- + error means - compensation.

When axis reach at compensation point in - direction

- error means - compensation
- + error means + compensation.

- Parameter number
- 024 : multiply ratio
 - 336 : Setting zero point of pitch error for X axis
 - 337 : Setting zero point of pitch error for Z axis
 - 383, 384 : distance of pitch error
 - 1000 ~ 1127 : Pitch error compensation amount for X axis.
 - 2000 ~ 2127 : Pitch error compensation amount for Z axis.

Ex. 2

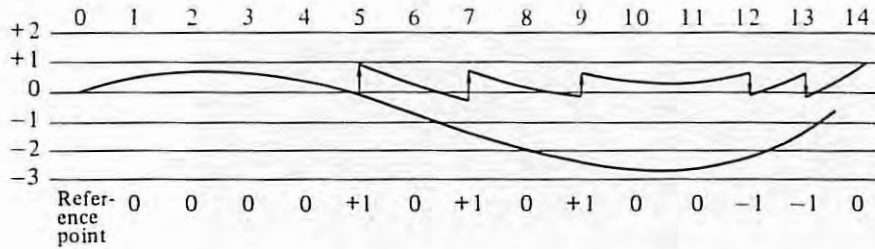

Note: Sign of compensation amount is changed by moving direction, but it doesn't have relation with zero position.

The Number indicated in the table below should be set on number indicator.

Setting and display contents at address SET

Number	Content
000	Setting (RMT, INCH, ISO)
*057	Run time (TMHOR)
*058	Run time (TMMIN)
*059	Run time (TMSEC)
*064	Chamfering width of thread
*065	Return amount in G74, G75
*066	Finishing allowance in G76
*067	Escaping amount in G71, G72
*068	Minimum cutting depth in G76
*141	Run hour
*151	Second stored stroke limit Amount of X axis at first top
*152	Second stored stroke limit Amount of Z axis at first top
*153	Second stored stroke limit Amount of X axis at second top
*154	Second stored stroke limit Amount of Z axis at second top
*155	Third stored stroke limit Amount of X axis at first top
*156	Third stored stroke limit Amount of Z axis at first top
*157	Third stored stroke limit Amount of X axis at second top
*158	Third stored stroke limit Amount of Z axis at second top
*319	Various setting (PRG8, MSBL)
*340	Selecting input device
*341	Selecting output device

- Address SET should be selected.
- Blank is displayed in numbers except mentioned above.
- The values at the numbers marked with * can be set at the address PRM.

Display for number 000 in setting mode

```
SETTING DATA 01 : 00112 N0001

TV CHECK          =0 (0:OFF 1:ON)
PUNCH CODE        =1 (0:EIA 1:ISO)
INPUT UNIT         =0 (0:MM 1:INCH)
INPUT DEVICE 1    =0 (0:TAPE 1:RMT)
INPUT DEVICE 2    =1 (1:RS232C)

P                  LSK
```

Display for number 0057 ~ 341 in setting mode

```
SETTING DATA 02 : 00112 N0001

NO.   DATA   NO.   DATA
0057  0002   0152  1750000
0058  0058   0153  1000000
0059  0028   0154  1500000
0064  0010   0155  9000000
0065  2000   0156  9000000
0066  0200   0157  8000000
0067  1000   0158  8000000
0068  1000   0319  0000000
0141  0002   0340  0000
0151  3000000 0341  0001

P                  LSK
```

Contents of number 000 in setting mode

Item \ Display	0	1
TV CHECK	No	Yes
PUNCH CODE	EIA	ISO
INPUT UNIT	MM	INCH
INPUT DEVICE 1	NC tape	RMT
INPUT DEVICE 2	RMT, when registering program tape into memory	Input device by data number 340, when registering program tape into memory.

FANUC SYSTEM 6T PARAMETER TABLE (2)

NO	7	6	5	4	3	2	1	0	NO	7	6	5	4	3	2	1	0
165	-	-	-	-	2	5	0	0	341	-	-	-	-	-	-	3	
166	-	-	-	-	5	0	0	0	342	-	-	-	-	1	0	0	
167	-	-	-	-	-	-	-	0	343	-	-	-	-	-	9	9	
168	-	-	-	-	-	-	-	0	344	-	-	-	-	-	9	9	
169	-	-	-	-	-	-	-	0	345	-	-	-	-	-	9	9	
170	-	-	-	-	-	-	-	0	346	-	-	-	-	-	9	9	
171	-	-	-	-	-	-	-	0	347	-	-	-	-	-	-	0	
172	-	-	-	-	-	-	-	0	348	-	-	-	-	-	-	0	
173	-	-	-	-	-	-	-	0	349	-	-	-	-	-	-	0	
174	-	-	-	-	-	-	-	0	350	-	-	-	-	-	-	0	
175	-	-	-	-	-	-	-	0	351	-	-	-	-	-	-	0	
176	-	-	-	-	-	-	-	0	352	-	-	-	-	-	-	0	
178	-	-	-	-	-	-	-	0	353	-	-	-	-	-	-	0	
179	-	-	-	-	-	-	-	0	354	-	-	-	-	-	-	0	
									355	-	-	-	-	-	-	0	
300	Refer to data sheet									356	-	-	-	-	-	-	0
301	Refer to data sheet									357	-	-	-	-	-	-	0
302	Refer to data sheet									358	-	-	-	-	-	-	0
303	Refer to data sheet									359	-	-	-	-	-	-	0
304	Refer to data sheet									360	-	-	-	-	-	-	0
305	0	0	0	0	0	0	0	0	361	-	-	-	-	-	-	0	
306	0	0	0	0	0	0	0	0	362	-	-	-	-	-	-	0	
307	0	0	0	0	0	0	0	0	363	-	-	-	-	-	-	0	
308	0	0	0	0	0	0	0	0	364	-	-	-	-	-	-	0	
309	0	0	0	0	0	0	0	0	365	-	-	-	-	-	-	0	
310	0	0	1	1	0	0	1	0	366	-	-	-	-	-	-	0	
311	0	0	0	1	1	0	0	1	367	-	-	-	-	-	-	0	
312	0	0	0	1	1	0	0	1	368	-	-	-	-	-	-	0	
313	0	0	0	1	-	-	-	-	369	-	-	-	-	-	-	0	
314	0	0	0	0	0	0	0	0	370	-	-	-	-	-	-	0	
315	0	0	0	0	0	0	0	0	371	-	-	-	-	-	-	0	
316	0	0	0	0	Refer to data sheet					372	-	-	-	-	-	-	0
317	0	1	0	0	1	0	0	1	373	-	-	-	-	-	-	0	
318	0	0	0	0	0	0	0	0	374	-	-	-	-	-	-	0	
319	0	0	0	0	0	0	0	0	375	-	-	-	-	-	-	0	
320	-	-	-	-	-	-	-	0	376	-	-	-	-	-	-	0	
321	-	-	-	-	-	-	-	0	377	-	-	-	-	-	-	0	
322	-	-	-	-	-	-	-	0	378	-	-	-	-	-	-	0	
324	-	-	-	-	-	-	-	0	379	-	-	-	-	-	-	0	
325	-	-	-	-	-	-	-	0	380	-	-	-	-	-	-	0	
326	-	-	-	-	-	-	-	0									
327	-	-	-	-	-	-	-	0									
328	-	-	-	-	-	-	-	0									
329	-	-	-	-	-	-	-	0									
330	-	-	-	-	-	-	-	0									
331	-	-	-	-	-	-	-	0									
332	-	-	-	-	-	-	-	0									
333	-	-	-	-	-	-	-	0									
334	-	-	-	-	-	-	-	0									
335	-	-	-	-	-	-	-	0									
336	-	-	-	-	-	-	-	0									
337	-	-	-	-	-	-	-	0									
338	-	-	-	-	-	-	-	0									
339	-	-	-	-	-	-	-	0									
340	-	-	-	-	-	-	-	2									

6. SETTING OF PCB

(1) Setting position is shown as below

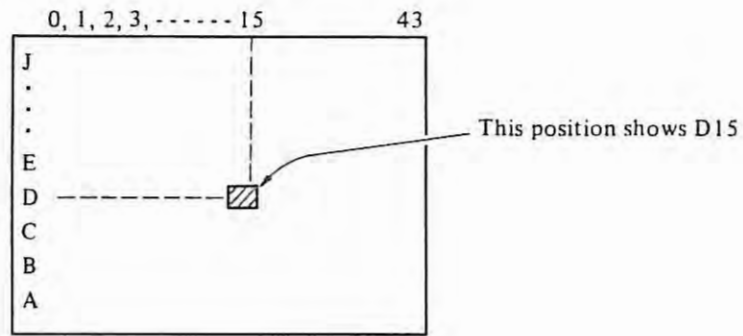

(2) Type of setting is as below.

A: Large pin

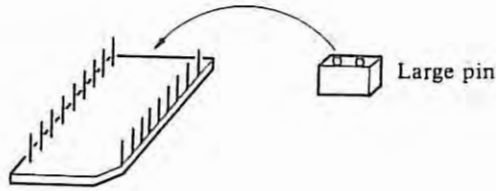

B: Small pin

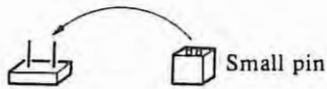

C: Terminal



This terminal has been fixed with soldering and normally needs not to be changed.

V: Variable



(3) Edition number of function in PCB is printed as below on the PCB.

Ex. A20B-0008-0410/03A

└───┬───> This shows edition number 03A of function.

6.1 Setting and adjustment for control section PCB

Contents	Items
Setting table for control section	6.1.1
Setting on master PCB A20B-0008-0410	6.1.2
Setting on ROM card	6.1.3
Setting on connection unit PCB A20B-0007-0040, 1	6.1.4
Inductosyn/resolver interface PCB A20B-0008-0461	6.1.5
Master PCB A20B-0008-0410 mounting diagram	6.1.6
ROM card A20B-0008-0420, 0480 mounting diagram	6.1.7
Connection unit A20B-0007-0040 mounting diagram	6.1.8
Resolver/inductosyn interface PCB mounting diagram	6.1.9 ~
FANUC PC MODEL B A-20B-0008-0440 mounting diagram	6.1.12

6.1.1 Setting table for control section

(1) Master PCB (PCB-A) A20B-0008-0410

Name	Location	Type	Function	Remarks
SPA1	B2	A	Servo status setting	
APA2	B3	A	X axis reference point return method: Grid/Magneswitch	Only with edition 01A
SPA3	B7	A	Z axis reference point return method: Grid/Magneswitch	Only with edition 01A
SPA4	B9	A	Position coder selection.	
SPA5	B12	A	Position coder selection	
SPA6	F3	A	Setting of velocity feedback method in X axis	
SPA7	E3	A	Setting of velocity feedback method in Z axis	
SPA8	D3	A	Not use.	
SPA9	J8 or J11	A	Setting of 16.384 MHz clock pulse width	
SPA10	C11	A	Setting of reference point return	Only with edition 02B and later
VR1 ~ 3	E2, D2, C2	V	Zero point adjustment for F/V converter	Only with edition 01A

(2) ROM card (PCB-B) A20B-0008-0420 (For 2532) A20B-0008-0480 (For 2732)

Name	Location	Type	Function	Remarks
SPB	F4	B	Set "Enable": Set "Disable" only when FANUC PC-MODEL A PCB is used	

(3) Connection with (PCB-D) A20B-0007-0040, -0041 or A20B-0008-0540

Name	Location	Type	Function
S1	E45	A	Setting of connection unit (1, 2)
S2	E15	A	Selection of output

(4) Resolver/inductosyn control PCB A20B-0008-0461.

Name	Location	Type	Function	Remarks
SPN1X SPN1Y	F5 F9	A	Selected gain range switching	
SPN2X SPN2Y	B5 B9	A	Switching between resolver and inductosyn. Division accuracy adjustment's presence or absence.	
GAIN	F3 F7	V	Detected gain adjustment.	
FMIN	H3 H7	V	DSCG method F min adjustment.	
FMAX	J3 J7	V	DSCG method F max adjustment.	
BALANCE	B3 B7	V	Adjustment of inductosyn division accuracy.	

SPN1X, SPN2X: X axis. SPN1Y, SPN2Y: Z axis.

6.1.2 Setting on master PCB (A20B-0008-041)

(1) SPA1 (B2)

This setting is fixed.
(Without setting)

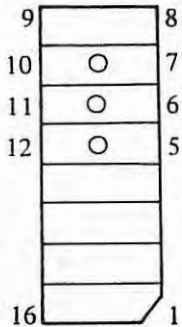

(2) SPA2 (B3)

X axis reference point return method. This setting is available for edition number 01A only.
Refer to item SPA10 about PCB since edition number 02B.

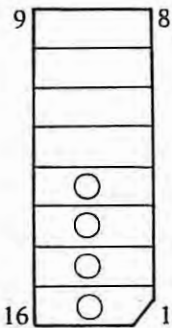

Grid method

	Grid method	Magneswitch method
9 - 8		<input type="radio"/>
10 - 7		<input type="radio"/>
11 - 6		<input type="radio"/>
12 - 5		
13 - 4	<input type="radio"/>	
14 - 3	<input type="radio"/>	
15 - 2	<input type="radio"/>	
16 - 1	<input type="radio"/>	

Note: One rotation signal of pulse coder is used in Grid method.

(3) SPA3 (B7)

Z axis reference point return method. This setting is available for edition number 01A only. Refer to item SPA10 about PCB since edition number 02B.

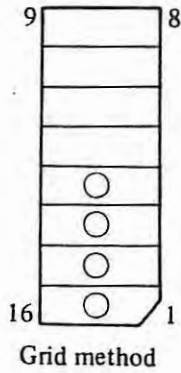

	Grid method	Magneswitch method
9 – 8		<input type="radio"/>
10 – 7		<input type="radio"/>
11 – 6		<input type="radio"/>
12 – 5		
13 – 4	<input type="radio"/>	
14 – 3	<input type="radio"/>	
15 – 2	<input type="radio"/>	
16 – 1	<input type="radio"/>	

(4) SPA4 (B9) (B11 for edition number 01 A)

Position coder selection 1.

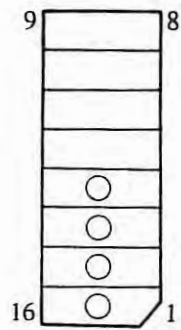

	3500 rpm (Single line type)	4000, 5000, 6000 rpm (Balanced transmission type)
9 – 8	<input type="radio"/>	
10 – 7	<input type="radio"/>	
11 – 6	<input type="radio"/>	
12 – 5	<input type="radio"/>	
13 – 4		<input type="radio"/>
14 – 3		<input type="radio"/>
15 – 2		<input type="radio"/>
16 – 1		<input type="radio"/>

(5) SPA5 (B12)

Position coder selection 2.

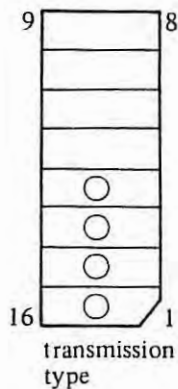

	3500 rpm (Single line type)	4000, 5000, 6000 rpm (Balanced transmission type)
9 – 8	<input type="radio"/>	
10 – 7	<input type="radio"/>	
11 – 6	<input type="radio"/>	
12 – 6	<input type="radio"/>	
13 – 4		<input type="radio"/>
14 – 3		<input type="radio"/>
15 – 2		<input type="radio"/>
16 – 1		<input type="radio"/>

(6) SPA6 (F3)

X axis velocity feedback

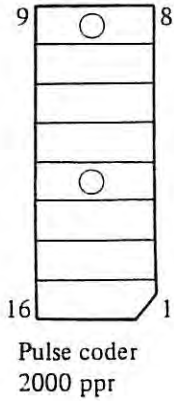

	Tacho-generator	Pulse coder + F/V convertor		
		2000 ppr	2500 ppr	3000 ppr
9 – 8		○		
10 – 7				
11 – 6	○		○	
12 – 5				○
13 – 4		○	○	○
14 – 3	○			
15 – 2				
16 – 1				

Note) Setting of 3000 ppr is effective from PCB edition 07D.

(7) SPA7 (E3)

Z axis velocity feedback

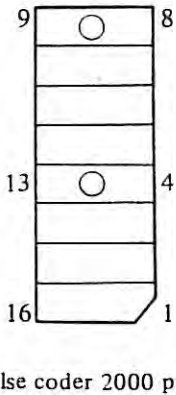

	Tacho-generator	Pulse coder + F/V convertor		
		2000 ppr	2500 ppr	3000 ppr
9 – 8		○		
10 – 7				
11 – 6	○		○	
12 – 5				○
13 – 4		○	○	○
14 – 3	○			
15 – 2				
16 – 1				

Note) Setting of 3000 ppr is effective from PCB edition 07D.

(8) SPA8 (D3) (B11 for edition number 01A)

This setting is fixed

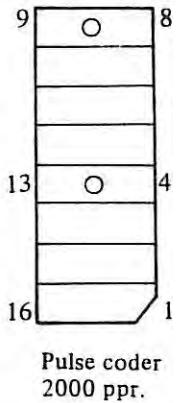

(9) SPA9 (J8) (J11 for edition number 01A)

This setting is fixed. (Setting of clock *C16M pulse for position control)

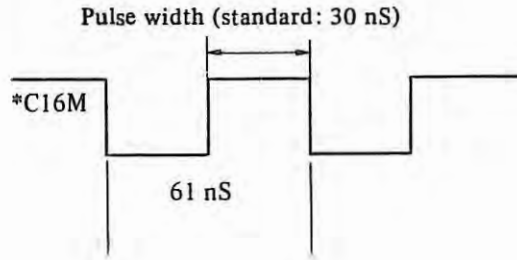
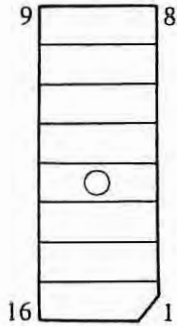

(10) SPA10 (C11)

Reference point return method.

This setting is available for 02B and later.

For 01A, SPA2 and 3 are used instead of this setting.

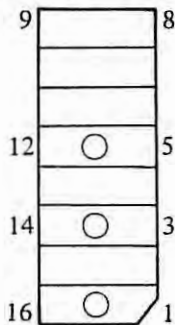

Grid method
for X, Y and
Z axes

9 - 8		(Fixed)
10 - 7		
11 - 6		
12 - 5	○	

	Z axis	
	Grid method	Magneswitch method
13 - 4		○
14 - 3	○	

	X axis	
	Grid method	Magneswitch method
15 - 2		○
16 - 1	○	

9-8 } not use.
10-7 }

(11) Setting pin at G9 is for spare.

Note) "Magneswitch" in the tables means magneswitch signal from machine side is input to Connector C07 ZDX ~ ZDZ.

In case that magneswitch signal is converted and is input as pulse coder 1 revolution signal, please set as "Grid" in the tables above.

6.1.3 Setting on ROM card

(1) SPB (F4)

Always set to Enable irrespective of with/without FANUC PC-MODEL A.

Should be set to Disable when RAM board of FANUC PC-MODEL A is used.

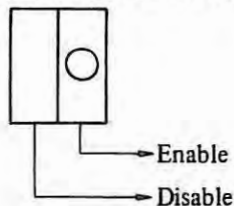

6.1.4 Setting on Connection Unit PCB (A20B-0007-0040 ~ 1)

(1) S1 (E45) Connection Unit 1 or 2

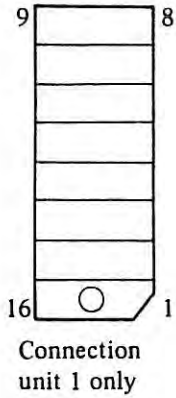

	Setting on connection unit 1		Setting on connection unit 2
	Connection unit 1 only	Connection unit 2 is also used.	
9 - 8			
10 - 7			
11 - 6			
12 - 5			
13 - 4			
14 - 3			○
15 - 2		○	
16 - 1	○		

(2) S2 (E15) Change of common for lamp

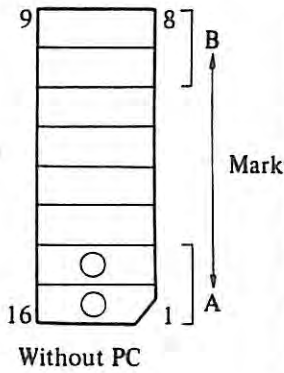

	Setting on connection unit 1		Setting on connection unit 2
	Without PC	With PC	
9 - 8		○	○
10 - 7		○	○
11 - 6			
12 - 5			
13 - 4			
14 - 3			
15 - 2	○		
16 - 1	○		

Setting A

Setting B

- A: Common is connected to +24N in the NC.
- B: Common is connected to machine side.

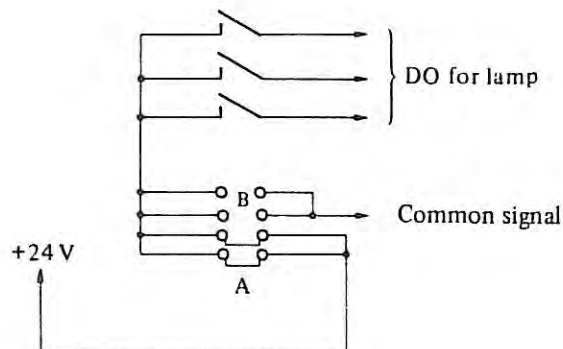

6.1.5 Inductosyn/resolver interface PCB A20B-0008-0461

Standard setting and adjustment

Name	Pin number	Resolver	Inductosyn	Remarks
SPN1 α				
SPN2 α	8-9			Not use
	7-10			
	6-11	○	○	Division accuracy adjustment is invalid.
	5-12	○		Resolver.
	4-13	○		Resolver.
	3-14	○		Resolver.
	2-15	○		Resolver.
	1-16	○		Resolver.
VR1 α		* 0% (Fully CCW)	0% (Fully CCW)	Detected gain.
VR2 α		Adjusted	Adjusted	F min
VR3 α		Adjusted	Adjusted	F max
VR4 α		—	To be adjusted only when required	Division accuracy SPN2 α (7-10) Short SPN2 α (6-11) Open

α : X, Y. (α = X: X axis. α = Y: Z axis. α = Z: not used).

○: Connect

* : For multipole resolver, set 6%

(A) Adjustment of detected gain

The resolver and the inductosyn excite the primary coil and detect positional information from the secondary-coil output signal. The voltage transfer ratio between the primary and secondary coils varies with the resolver type, the inductosyn type, and the gap distance, whereby the secondary-coil output level varies as well. Also, since the output impedance varies with the inductosyn scale length, the secondary-coil output level is also affected. The detected gain need be adjusted according to the secondary-coil output level, but when no abnormal alarms (414, 424) occur in the resolver/inductosyn position detector, usually the detected gain need not be adjusted.

1) Adjusting locations

Detected gain	Setting	Variable resistor
Raise	Disconnect	Rotate CW (0% to 90%)
Lower	Connect	Rotate CCW (85% to 0%)

	Setting pin	Disconnect	Connect
X axis	SPN1X		
Z axis	SPN1Y		

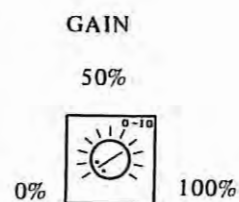

Example: 0%

2) Adjusting procedure of detected gain

Prepare a synchroscope and a jumper with clips (10 cm or more).

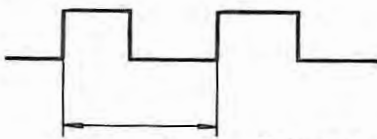
Step	Operation
1	Set the parameters: PHS = 1 (013, bit 4) GRD α = 0 (082-083), where α = X, Z CDSCG = 1 (316, bit 7)
2	Power OFF, then ON. (When DSCG alarm does not disappear, another trouble has occurred.)
3	Perform Reference Point Return. (Observe TP11 α -GND: high-level pulse width of up to 0.5 μ sec also will do.)
4	Move the machine tool by 100/4000 wavelength. (When Detect Multiply is 1, detection unit is 100; when 1/2, 50.)
5	Set the parameters: CDSCG = 0 (316, bit 7th)
6	Power OFF.
7	Jumper TP9-GND. (Input of detected pulse to position LSI stops.)
8	Power ON. (DSCG abnormal alarm 414, 424, 434 or 444 must always occur.)
9	Observe TP5 α -GND on the oscilloscope to adjust detected gain. (when frequency is low, detected gain becomes low.)  Standard 4 μ sec. Tolerance range 3.1 μ sec – 7.2 μ sec
10	Open TP9 and set parameter PHS to 0 (013, bit 4th).
11	Power OFF, then ON.
12	Set parameter PHS to 1 (013, bit 4th).
13	Repeat steps 6-12 to make sure that adjustment is correct.
14	Restore the parameters. GRD = original value (082-083) CDSCG = 0 (316, bit 7th).

3) A rule of thumb for adjustment

With an inductosyn, this rule of thumb may vary according to the maker and to the gap distance.

Position Detector		Setting	Variable resistor
Standard resolver (motor built-in type)		Dis-connect	* 0%
Linear inductosyn	Scale length of up to 2m		0%
	Scale length of over 2m		More than 0%
Tape or narrow inductosyn	Scale length of up to 2m		65%
	Scale length of over 2m	More than 65%	
Rotary inductosyn	12 inches, 360 poles	Connect	0%
	12 inches, 720 poles		65%
	7 inches, 360 poles	Dis-connect	0%
	7 inches, 720 poles		50%

* For multipole resolver, set 60%.

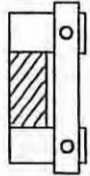
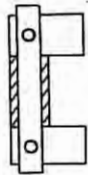
	X axis	Z axis
Name	SPN1X	SPN1Y
Dis-connect		
Connect		

(B) Adjustment of resolver/inductosyn Fmin and Fmax

Adjust with the Emergency stop button ON.

Item	Adjustment
Fmin	This item has been adjusted at shipment from the factory: usually it need not be readjusted. Use a frequency counter or oscilloscope for adjustment. Jumper TP8 α -GND. Observe TP5 α -GND. Adjusting volume: FMIN Frequency range: 1.67 kHz \pm 150 Hz (Frequency: 0.6 msec \pm 0.06 msec)
Fmax	This item has been adjusted at shipment from the factory: usually it need not be readjusted. Use a frequency counter (not a oscilloscope, which provides no exact adjustment). Jumper TP8 α and -15V. Observe TP5 α -GND. Adjusting volume: FMAX Frequency range: 850 kHz \pm 20 kHz (Frequency: 1.18 μ s \pm 0.045 μ s)

(C) Adjustment of inductosyn division accuracy

With division accuracy adjustment set absent, usually a fairly good accuracy can be attained. When division accuracy adjustment set present, adjustment need be made at all times.

Adjusting location		No division adjustment	Division adjustment
SPN2 α or SPH6	7-10		○
	6-11	○	
Variable resistor BALANCE		Arbitrary	10 ~ 40%

1) Simple method

Feed the machine tool at low speed and observe motor-current waveforms on a oscilloscope to adjust volume BALANCE so that current-waveform swell may be smallest. But a division error will cause current waveforms to swell twice per wavelength of inductosyn. The swell frequency is propotionate to the feed rate and as the feed rate becomes more than a certain degree, usually the swell disappears. From the above characteristics, whether or not current-waveform swell occurs for another cause, is checked.

2) Strict method

Adjustment is made by actually measuring the machine tool position, using a high-precision, high-resolution measuring instrument, such as a laser measuring machine. One wavelength of an inductosyn is divided by the NC and the position is detected in resolutions of 1/4000. The accuracy that one wavelength is divided is called the division accuracy. The accuracy within one wavelength is strongly affected by the NC position detector circuit and the position accuracy of an integral multiple of one wavelength depends primarily on the scale accuracy.

The division accuracy is checked by dividing one wavelength into 1/10 or 1/20, measuring the positioning accuracy, writing the error on a graph, and viewing the distance of each division point from a straight line connecting the both ends of the one wavelength.

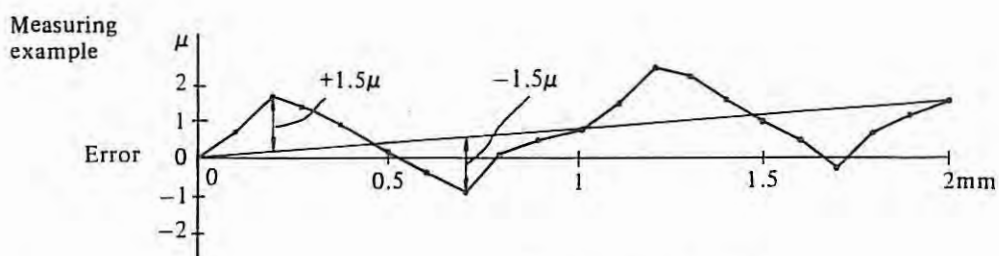
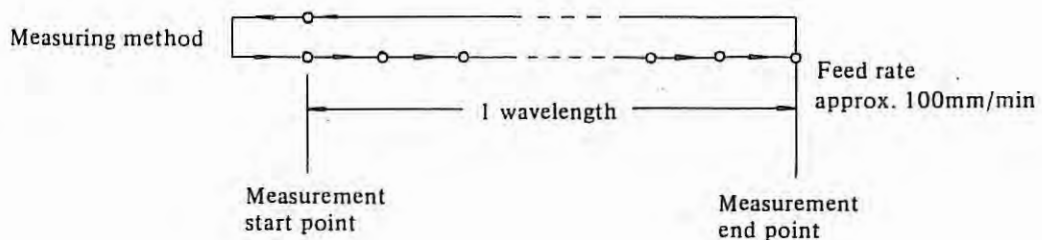

Division error 3 μ wide.

Adjusting volume BALANCE

Measure their respective division accuracy at degrees 2 and 3 on the volume, and write the errors on a graph. Rotate the volume by another one degree in the direction to the smaller error, measure the division accuracy, and observe the condition of the error. The error develops with its peak and valley positioned reversely between when the volume is rotated too much and when it is rotated too little. When it is not found clearly where the peak and the valley are, the volume is set at an optimum position.

A division error having a two-cycle swell per wavelength of inductosyn, can usually be improved by this adjustment. But a division error having a one-cycle swell or an irregular error cannot be improved by this adjustment. Examine other causes on inductosyn mounting, gap adjustment, slider replacement, etc.

Scale on the volume
Example: 3 scales

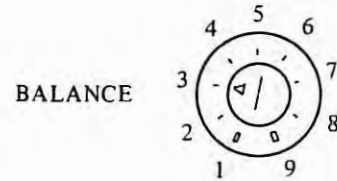

Adjusting example

The figure below suggests that about degree 2.8 is an optimum position for the knob to be set.

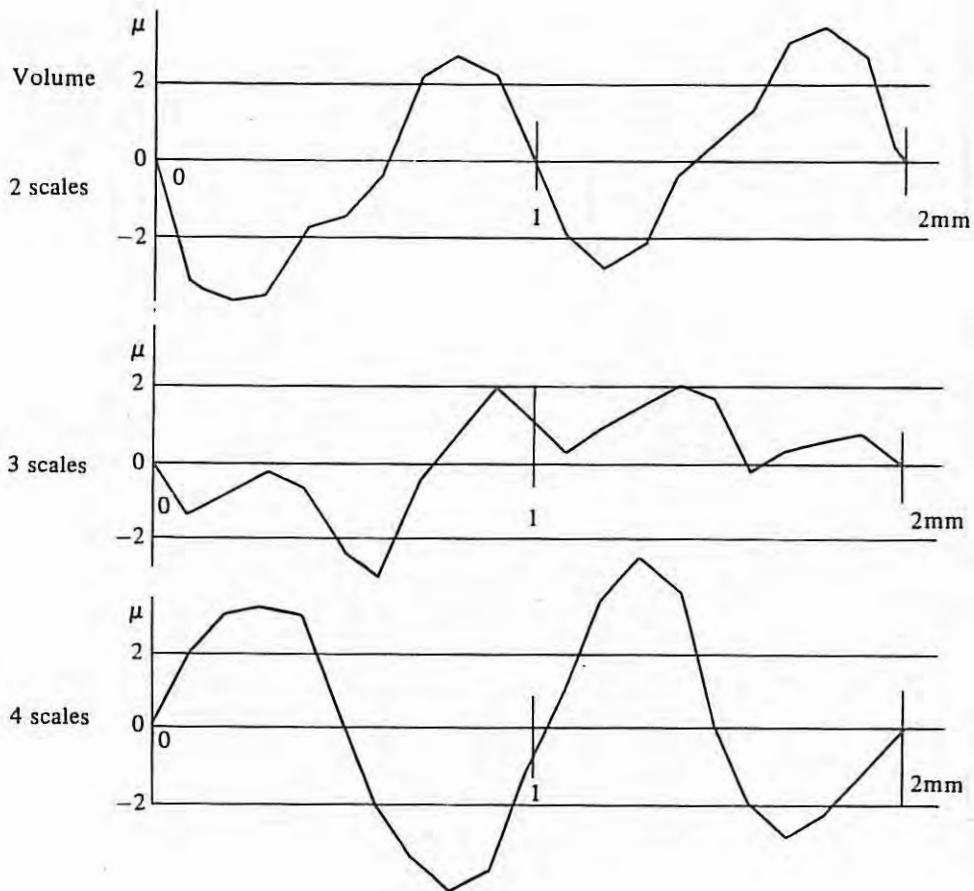

6.1.7 ROM Card A20B-0008-0420, 0480 mounting diagram

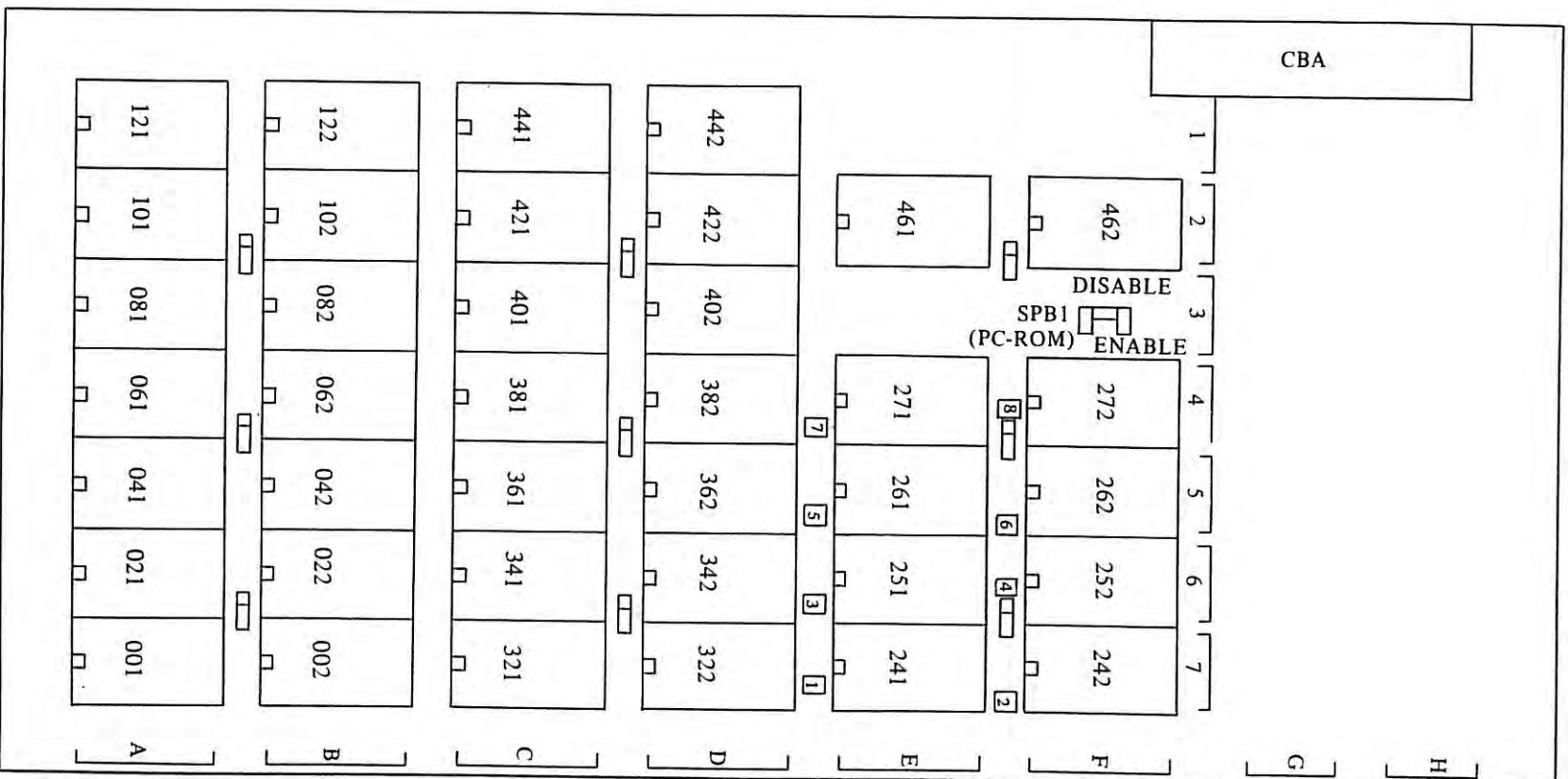

6.1.8 Connection unit (A20B-0007-0040 or A20B-0008-0540) mounting diagram

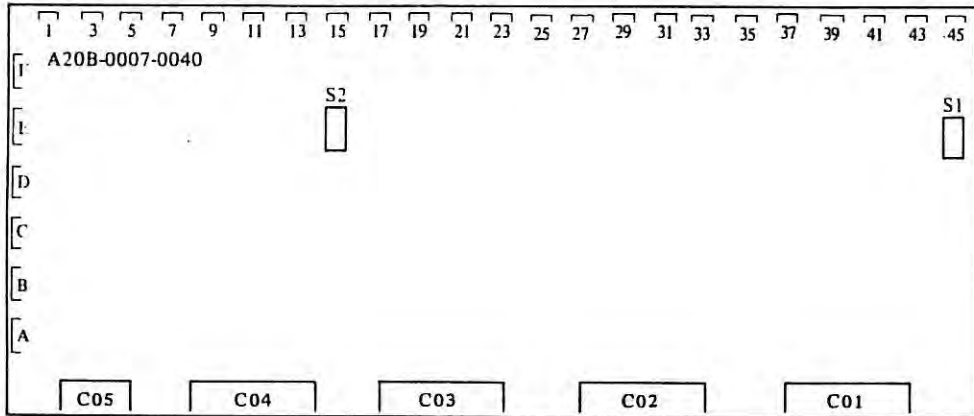

6.1.9 Additional axis (pulse coder) A20B-0007-0090 mounting diagram

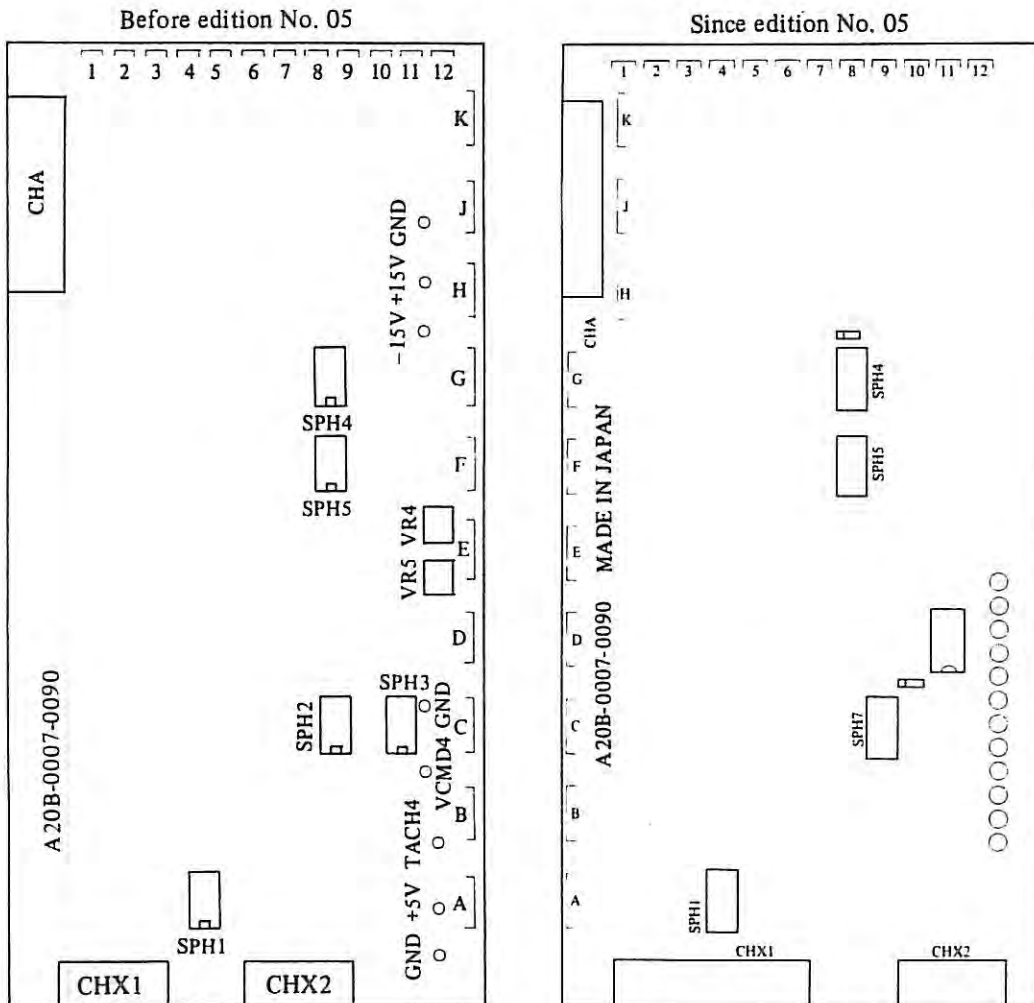

6.1.10 Resolver/Inductosyn interface PCB A20B-0008-0461 mounting diagram

(1) Since edition No. 02A

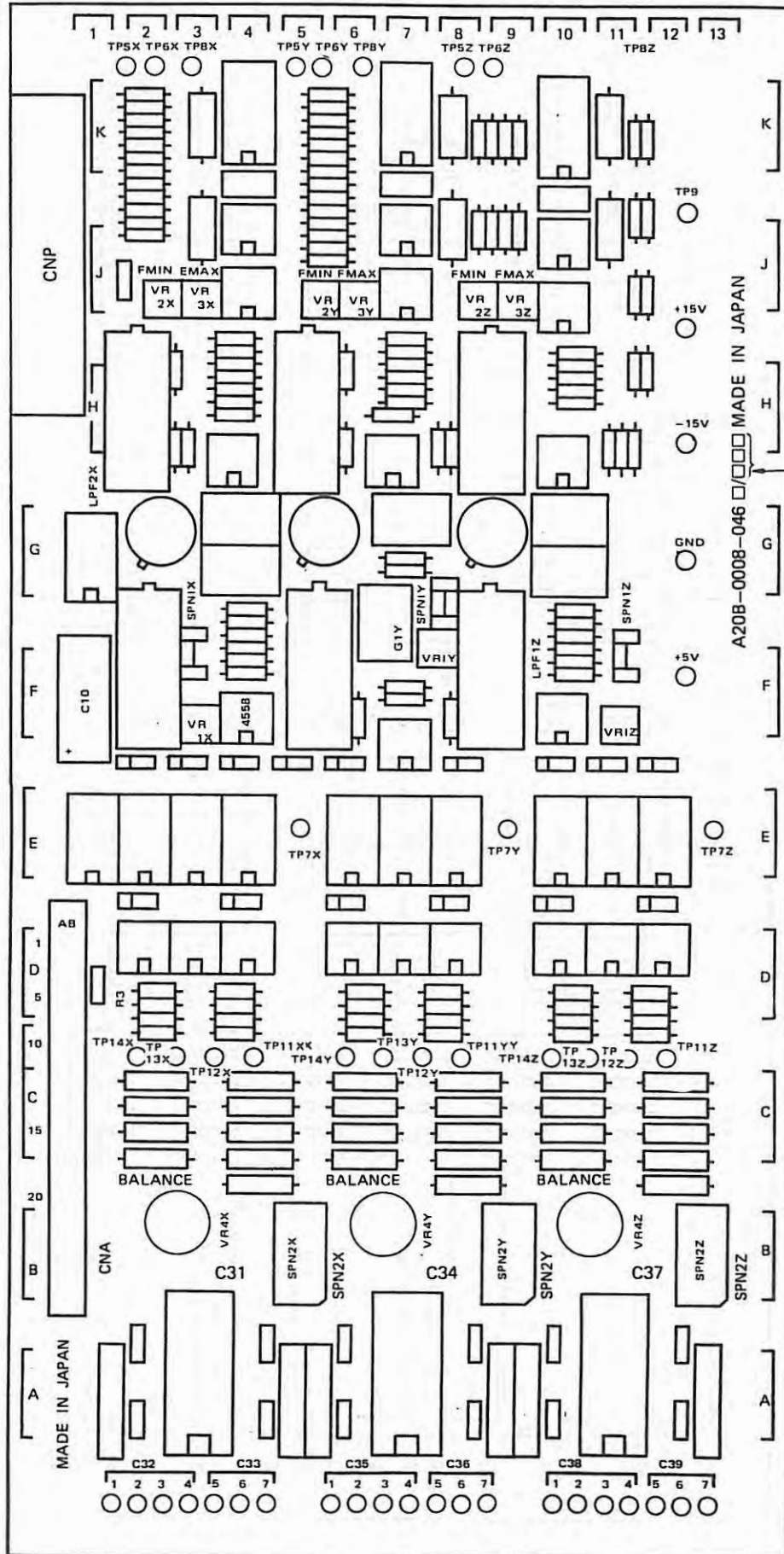

edition number

(2) For edition No. 01A

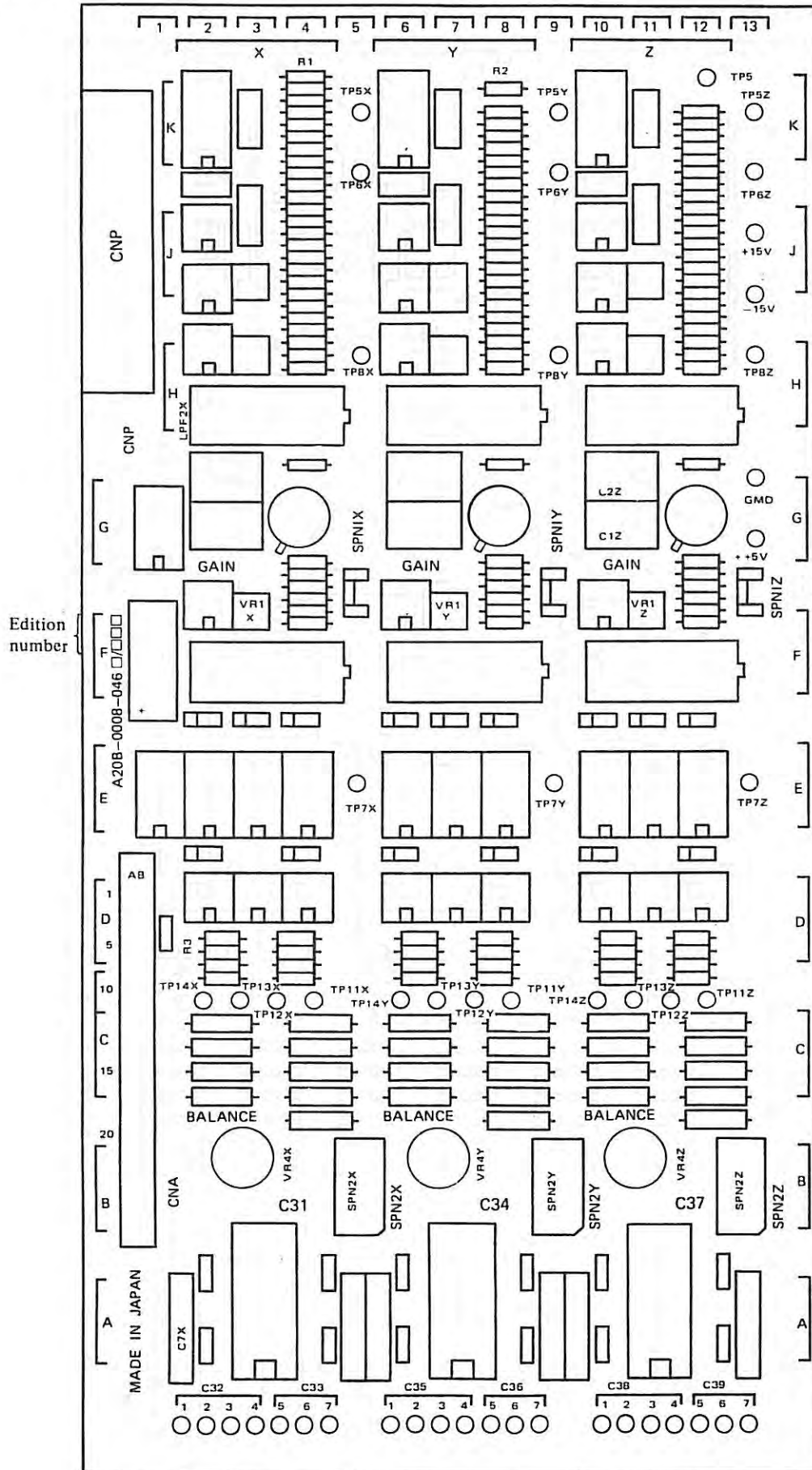

6.1.11 Additional axis control PCB (Resolver/Inductosyn) A20B-0007-0470, 471 mounting diagram

(1) Since edition No. 028, 03B

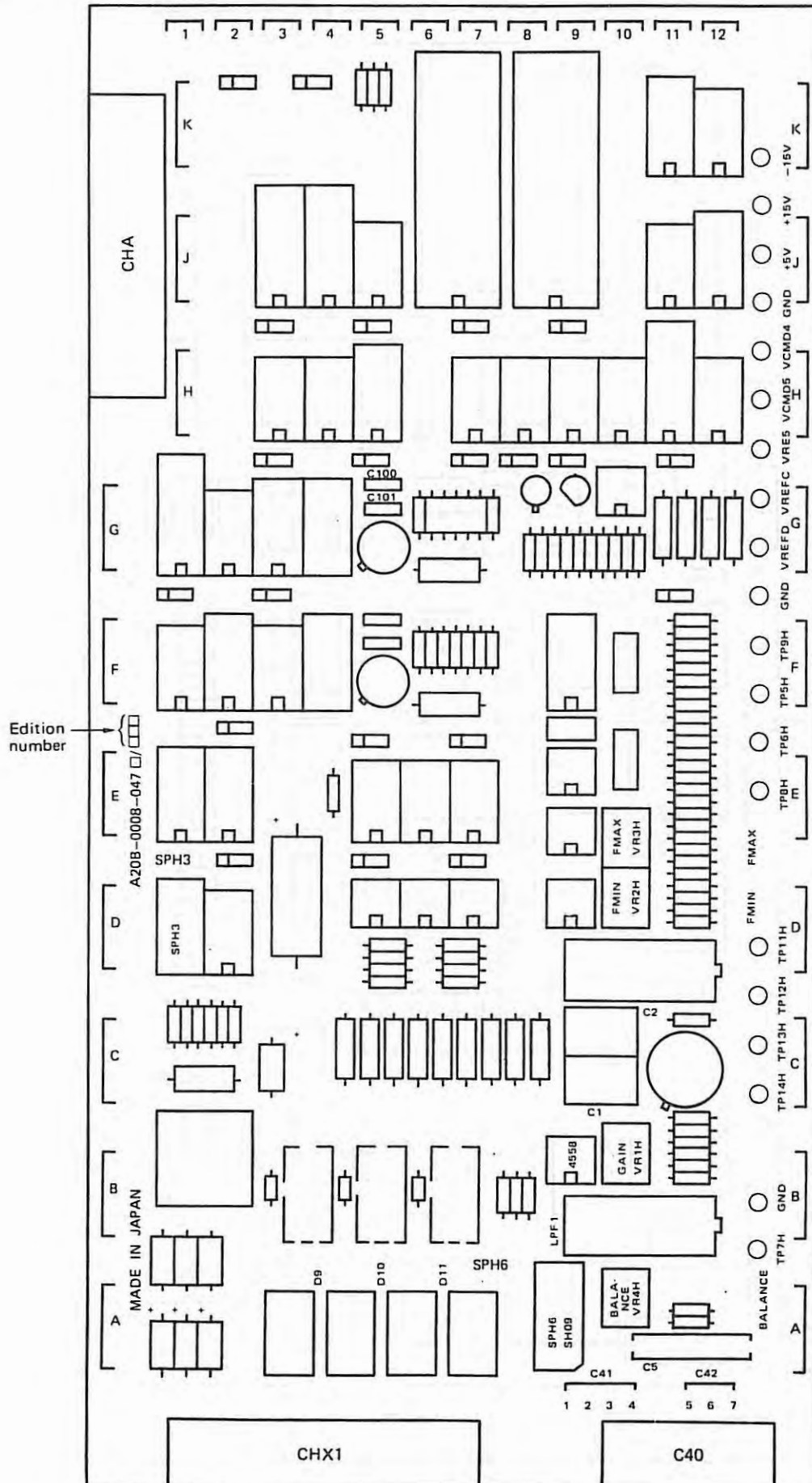

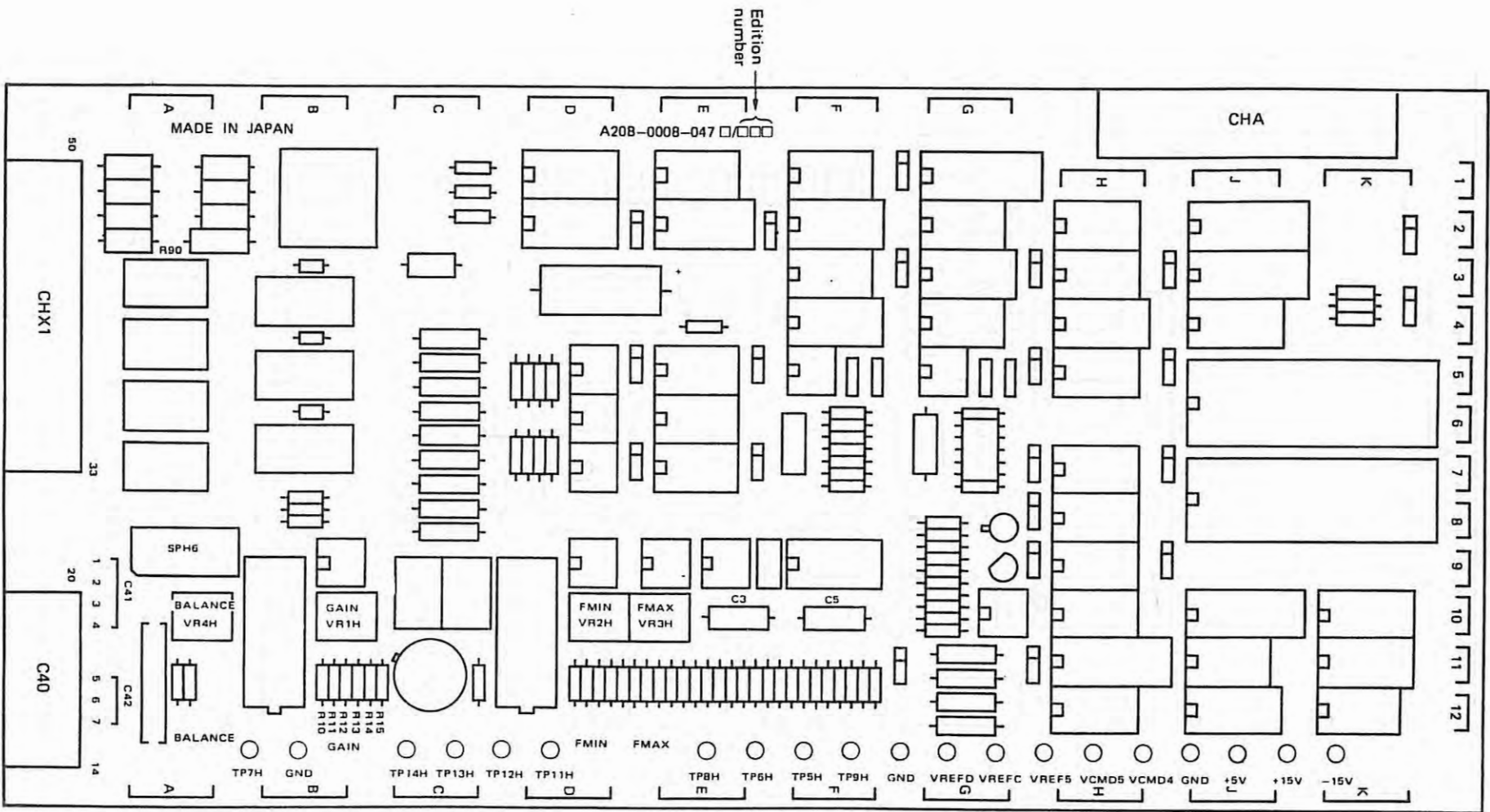

6.1.12 FANUC PC-MODEL B A20B-0008-0440 mounting diagram

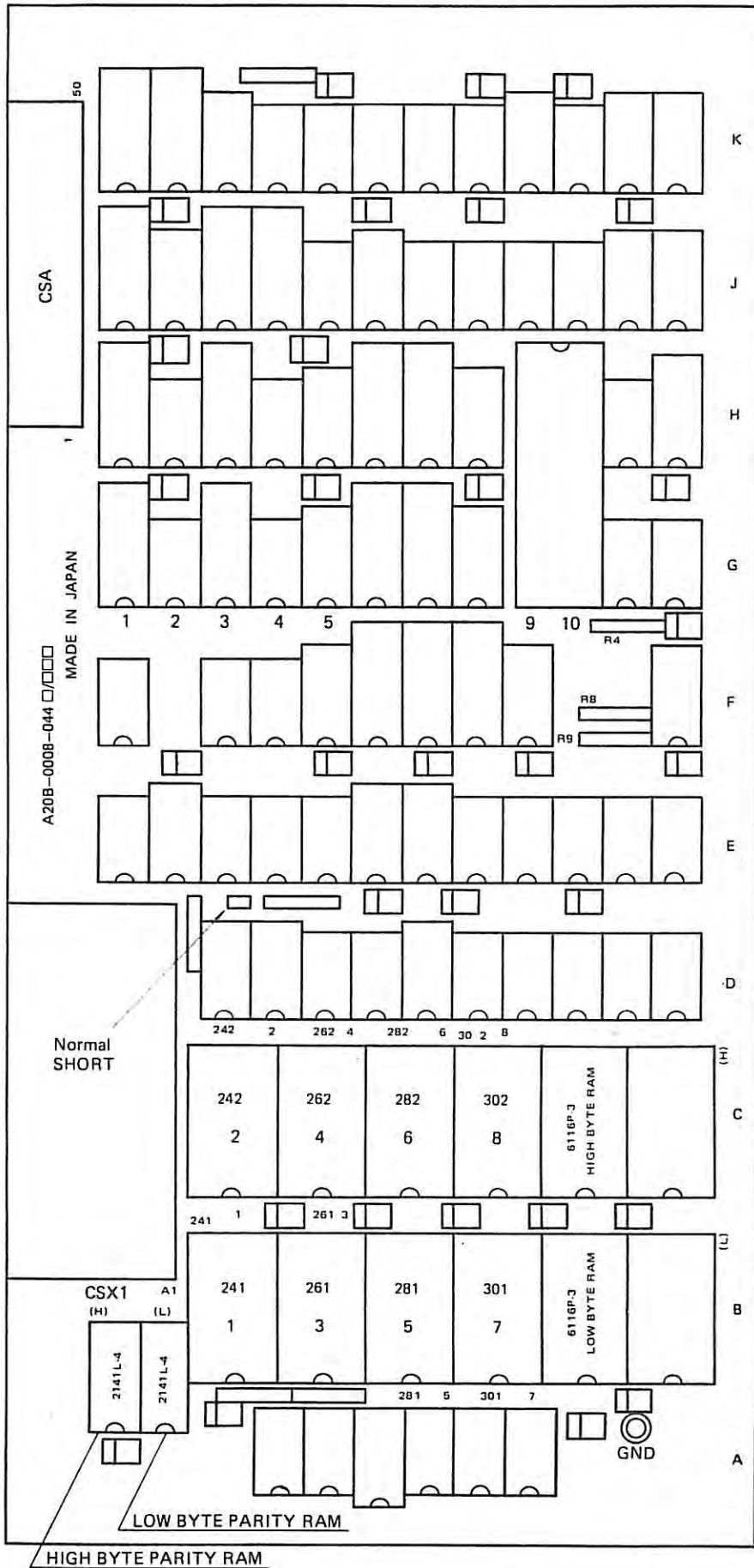

6.2 Setting and adjustment for velocity control unit

6.2.1 Setting and adjustment on velocity control unit PCB (A20B-0007-0360) (H series)

P.C.B. mounting diagram

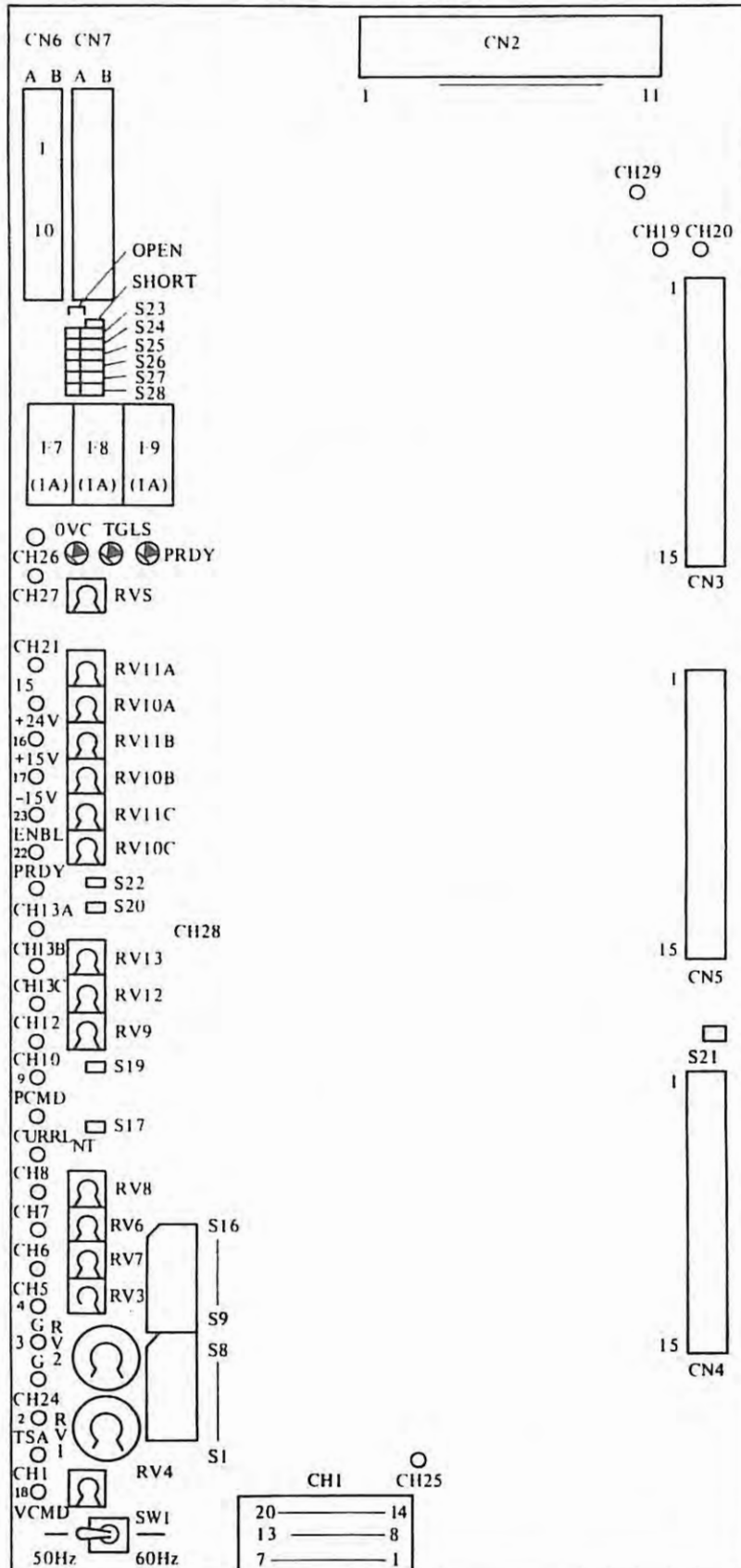

Fig. 1

Setting of Jumper

C Position to be Shortcircuited

Jumper	OL, 5L, UL, 5L		DN, 5N		10, 20, 30, 10H, 20H, 30H		
	Pulse Coder Tacho (3V)	Tacho (6V)	Pulse Coder Tacho (3V)	Pencak Tacho (6V)	Pulse Coder	Tacho (3V)	Pencak Tacho (6V)
S 1	○		○		○	○	○
S 2					○	○	○
S 3	○		○		○	○	○
S 4					○	○	○
S 5							
S 6	○	○	○	○	○	○	○
S 7	○	○	○	○	○	○	○
S 8	○	○	○	○			
S 9							
S10							
S11							
S12							
S13			○	○	○	○	○
S14	○	○	○	○			
S15	○	○	○	○			
S16			○	○	○	○	○
S17	○	○	○	○	○	○	○
S19	○	○	○	○	○	○	○
S20	See Note 1						
S21	See Note 2						
S22	Open						
S23 - 28							

See Note 1 and Fig. 1 Normality Short

Note 1 Connect Motor Power Line with T1 (5) - (8) : S20 Short
 Disconnect Motor Power Line with T1 (5)-(8) S20 Open
 S20 is TGLS Enable (But LED Works in All Condition)
 If S20 is Short, it Becomes Gate Blocking and Dynamic
 Braking by MCC Off at TGLS Alarm.

2 A20B-0007-0360 : S21 Open
 A20B-0007-0361 : S21 Short

3 In Case That You Replace Firing Circuit with New One.
 Note: The Following Diagram

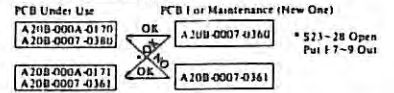

4 Volume Percentage is as follows.

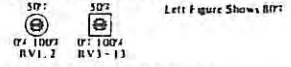

5 RV3 is Common-Mode Rejection Ratio (ADJ)
 Don't Move This Volume

6 If Setting is Impossible within the Range of Variation of
 RV10A, B, C,
 The Voltage of CH9 May be Changed within the Range of
 ±0.5V at RV3

7 After Such Adjustment is Made, Dither Can be Increased
 or Decreased at RV3

Adjustment of Pot and Check

POS	Item	Setting Condition			Setting and Check	Remarks
		Pot	Check-Pin	Shorting		
1	Check at Jumper				Check shall be made in accordance with above table	
2	Setting of 50/60Hz Switch	SW1			Change over SW1 to the frequency of Power Supply	
3	Check of DC Power Source		CH15-3 CH16-3 CH17-3		CH15-3 22 ~ 27V CH16-3 14.5 ~ 15.5V CH17-3 14.5 ~ 15.5V	CH15-3 ↑ ground
4	Gain	RV1			OL, 5L 60% DN, 5N 60% 10H ~ 30H 60%	
5	Offset	RV2	CH8-3	CH1-3	±0.5V Max	
6	Dither Voltage	RV3	CH9-3	CH8-3	50Hz 1.5 ± 0.05V	(Refer to Note b, 7)
					60Hz 3.00 ± 0.1V	
					Ta msec 10 Tb msec 2.1 ± 0.1	
Firing Angle Gain (Tb ADJ)	RV10A RV10B RV10C	CH13A-3 CH13B-3 CH13C-3	CH8-3	CH8-3	Make deviation of firing angle minimum Trigger	Over 10V -10V
					Balance ADJ	
7	Tacho-Generator Compensation	RV4			1) Normality 50%	
8	Current Detector AMP Offset	RV6	CH11-3		±10mV Max	
9	Current Feed-back Gain	RV7			OL, 5L 90% DN, 5N 30% 10H ~ 30H 20%	Criterion OL, 5L 30A (1/2) Scale (A) DN, 5N 35A Scale (A) 10H ~ 30H 70+44 Scale (A)
10	Current Limiter Gain	RV8			50% 40% 70%	
11	Current Limiter Setting	RV9			20% 50% 50%	
12	Overcurrent Alarm ADJ	RV12			100%	Criterion OL, 5L 6+Scale (A) DN, 5N 3+Scale (A) 10H ~ 40H 8+Scale (A) Step 4 Series D1
13	Error Clamp	RV13			60%	

Meaning of Check Terminal

CH 1	Velocity Command (VCM)	CH17	15V
CH 2	Tacho-Generator Signal (TSA) (1/1V Converter)	CH18	Velocity Command (VCM)
CH 3	0V	CH19	Current Detect (CD1)
CH 4	0V	CH20	Current Detect (CD2)
CH 5	Compensation C.K.T	CH21	Fuse Alarm (FA)
CH 6	Compensation C.K.T	CH22	Position Ready (PRDY)
CH 7	Current Detector Absolute Value C.K.T. Output	CH23	Firing Pulse Enable (ENBL)
CH 8	Compensation C.K.T.	CH24	Analog Amp. Check Terminal
CH 9	Phase Command (PCMD)	CH25	Analog Amp. Check Terminal
CH10	Total Error (ER)	CH26	Current Detector Amp. Check Terminal
CH11	Current Detector Output	CH27	Current Detector Amp. Check Terminal
CH12	Current Limiter Setting	CH28	Current Limiter Input
CH13A	Firing Angle	CH29	0V
CH13B			
CH13C			
CH15	+24V		
CH16	+15V		

Name	Color	Meaning
OVC	Red	Overcurrent Alarm (Set RV12) Motor Load is Too Heavy Movement of Motor become Hunting Load Inertia is Too High. Position Loop Gain is Too High AC Input Voltage is Too Low
TGLS	Red	Motor Runaway Alarm. Velocity Feedback Signal is Lost Motor Armature Connections is Burn-Out
PRDY	Green	Position ready signal goes on This lamp light on in normal

6.2.2 Setting and adjustment for velocity control PCB (A20B-0009-0320) (M series)

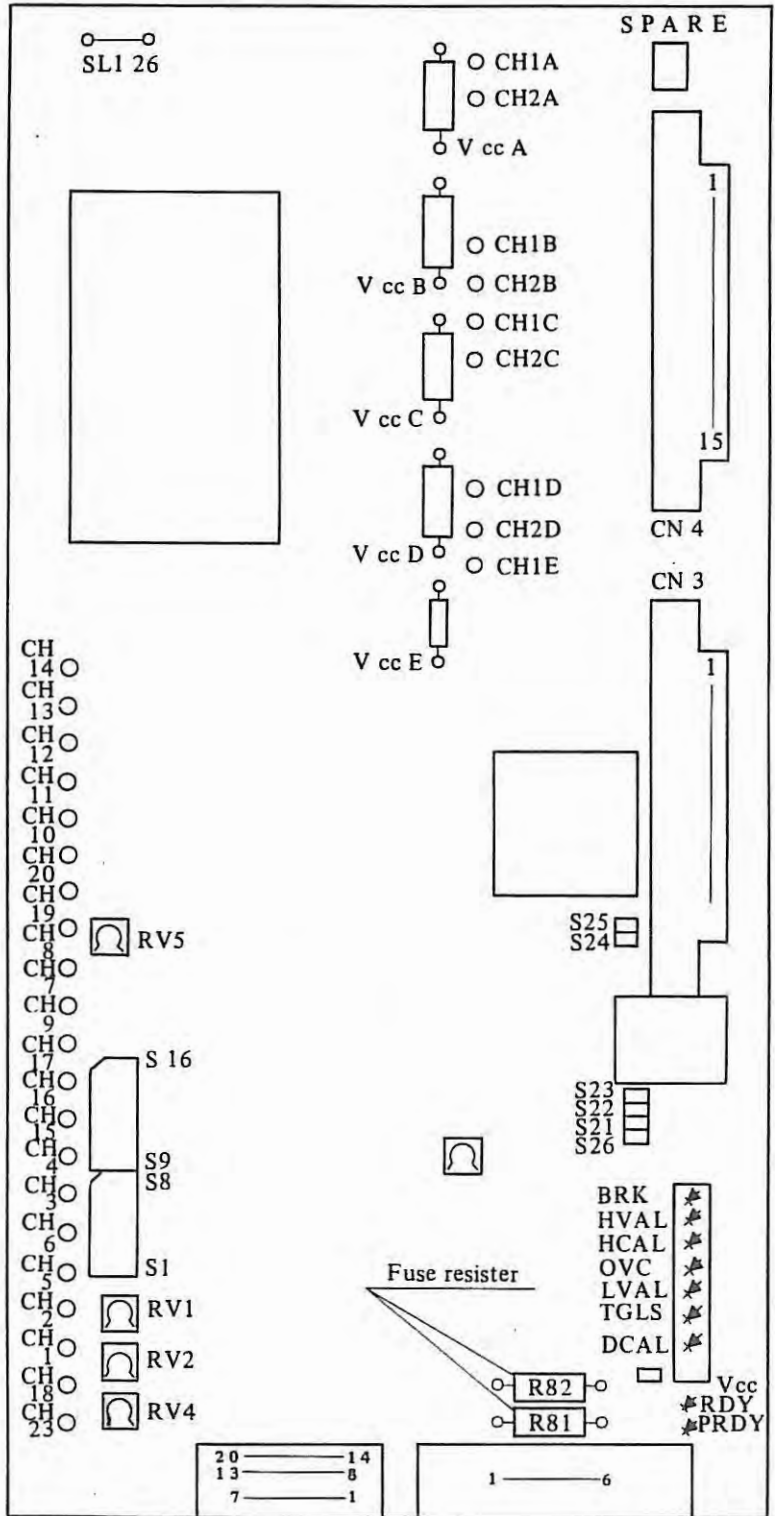

Note) Parts location on PCB may be changed without notice.

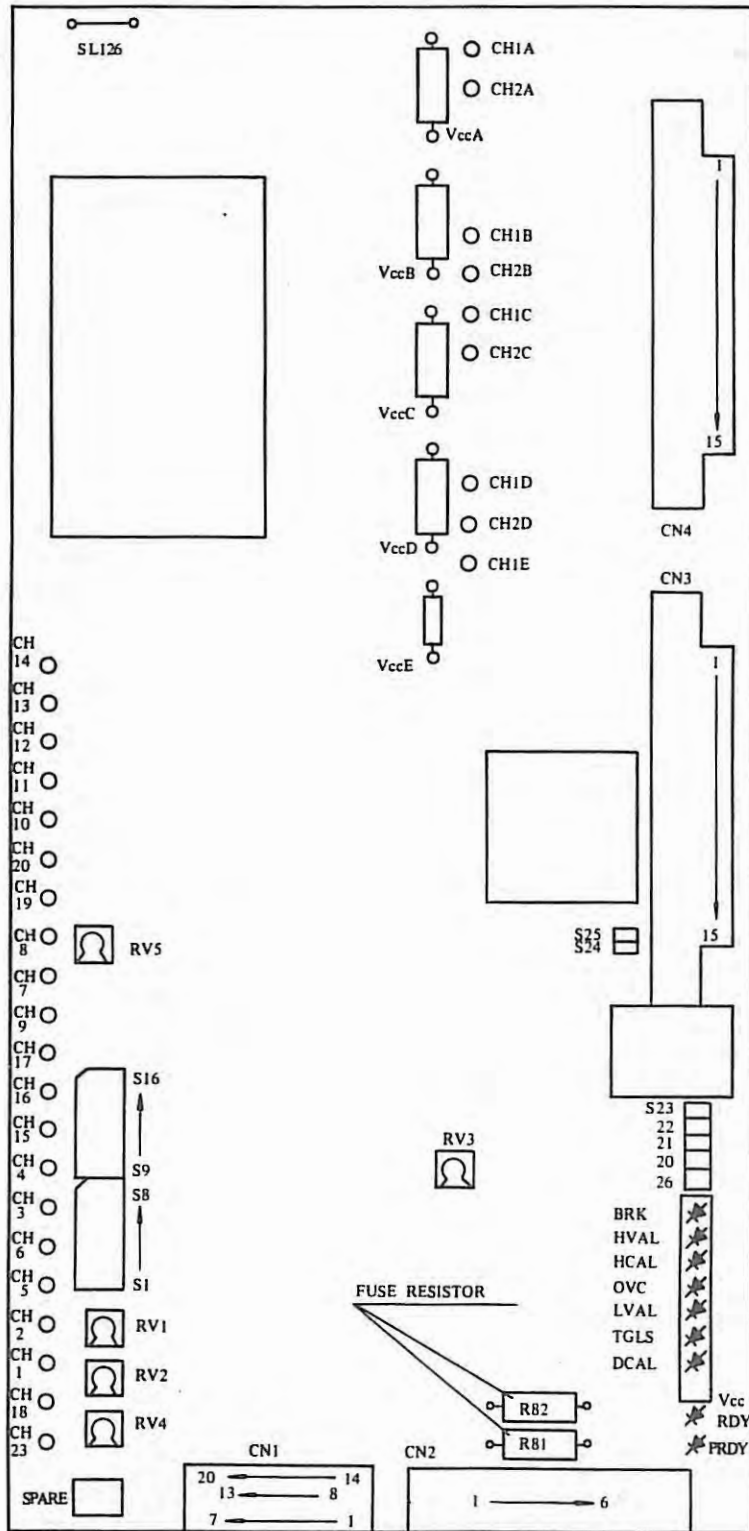
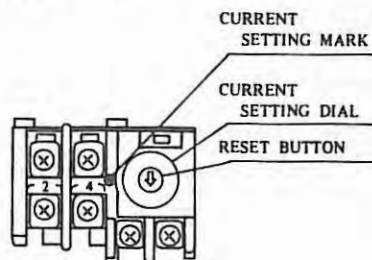

FIG. 1 (PARTS POSITION OF 07C*)

SETTING OF THERMAL RELAY

MOTOR MODEL	CURRENT
00M	4A
0M	6A
5M	9A
10M	12A
20M	18A
30M	24A
30MH	36A



SETTING OF JUMPER							○ : POSITION TO BE SHORTCIRCUITED	
JUMPER	00M		0M	5M	10M ~ 30M(H)		MEANING	
	PULSE CODER	PANCAKE TACHO	PULSE CODER	PANCAKE TACHO	PULSE CODER	PANCAKE TACHO		
S 1	○		○		○	○	TACHO-GENE. SETTING	
2					○		COMPRESSOR ENABLE	
3							GAIN ATTENUATOR	
4							HIGH FREQUENCY GAIN	
5	○	○	○	○	○	○	RIPPLE FILTER	
6	○	○	○	○	○	○	HIGH-GAIN C.K.T. ENABLE	
7	○	○	○	○	○	○	CAPACITOR FOR COMPENSATION C.K.T.	
8	○	○	○	○	○	○	DC GAIN	
9							CAPACITOR FOR HIGH-GAIN	
10	○	○	○	○	○	○	SEE NOTE6	
11							CHOPPING FREQUENCY SELECTOR	
12	○	○	○	○	○	○	THERMOSTAT FOR TRANSFORMER AND DISCHARGE UNIT ENABLE	
13							BRK ALARM ENABLE	
14							DCAL ALARM ENABLE	
15							TGLS ALARM ENABLE	
16	○	○	○	○	○	○	OVC ALARM OPERATING TIME SELECTOR	
17							TGLS ALARM SENSING LEVEL	
18	SEE NOTE1	←	←	←	←	←	DISCHARGE UNIT SELECTOR	
19							MOTOR SELECTOR FOR ARMATURE VOLTAGE FEEDBACK C.K.T.	
20								
21								
22								
23								
24	○	○	○	○	○	○		
25								
26	SEE NOTE2	←	←	←	←	←		
126	○	○						

ADJUSTMENT OF POT AND CHECK

POS	ITEM	SETTING CONDITION				REMARKS	
		POT	CHECK-PIN	SHORTING	SETTING AND CHECK		
1	CHECK AT JUMPER				CHECK SHALL BE MADE IN ACCORDANCE WITH ABOVE TABLE		
2	CHECK OF DC POWER SOURCE		CH15-3 CH16-3 CH17-3		CH15-3 22~27V	CH16-3 14.5~15.5V	CH17-3 14.5~15.5V
3	GAIN	RV1			5 SCALES		
4	OFFSET	RV2	CH6-3	CH1-3 CH2-3	±0.5V MAX		PANCAKE TACHO
					5 SCALES		PULSE CODER
5	OVERCURRENT ALARM ADJ.	RV3			10 SCALES	00M 0M~20M 30M(H)	0.6+1.1 X SCALE(A) 2 + 3.8 X SCALE(A) 4 + 7.5 X SCALE(A)
6	TACHO-GENERATOR COMPENSATION	RV4			1) NORMALITY 5 SCALES 2) USE FOR FINE ADJUSTING OF LOOP GAIN. REFER TO MAINTENANCE MANUAL OF NC.		
7	CURRENT LIMITER SETTING	RV5 SEE NOTE 5			9 SCALE	00M 0M~20M 30M(H)	564/(93-5X SCALE)(A) 1880/(93-5X SCALE)(A) 3760/(93-5X SCALE)(A)

- Note 1. IF CONNECTION BETWEEN CN2 (4) (5) AND TRANSFORMER OR DISCHARGE UNIT EXISTED.
2. IF YOU USED DISCHARGE UNIT, YOU WILL BE OPEN-CIRCUIT AT S26.
3. VOLUME SCALE IS AS FOLLOWS. FIGURE SHOWS 8 SCALES.
4. *MARKS IS TOTAL EDITION OF PCB.
5. CURRENT LIMITER FUNCTION IS APPLIED FOR PCB EDITION 02B OR LATER.
6. SETTING OF S15.

5 SCALES



0 10 SCALES

01A*	CURRENT LIMITER SETTING
02B*03B*	NO CONNECTION
04B*05B*	CHOPPING FREQUENCY SELECTOR
07C*~	0.022μF INTO HIGH FREQ. GAIN DO NOT SHORT S14, S15 TOGETHER

SYMBOL		MEANING OF CHECK TERMINAL			SYMBOL		
CH 1		3/4 X VCMD			CH11	PWA	PWM CKT OUTPUT FOR DRIVER A
2	TSA	TACHO-GENERATOR SIGNAL			12	PWB	" B
3	OV	OV			13	PWC	" C
4	OV				14	PWD	" D
5		COMPENSATION C.K.T.			15	+24V	+24V
6					16	+15V	+15V
7	TRIANGLE WAVE	SEE FIG. 2.			17	-15V	-15V
8	CURRENT	00M	0.66V/A		18	VCMD	VELOCITY COMMAND
		0M~20M	0.2V/A		19	VFB1	ARMATURE VOLTAGE FEEDBACK SIGNAL
		30M(H)	0.1V/A		20	VFB2	
9	ER	INPUT SIGNAL OF PWM C.K.T.			23	ENBL	DRIVER ENABLE
10	DISCHARGE	DISCHARGE MONITOR. SEE FIG. 3.					

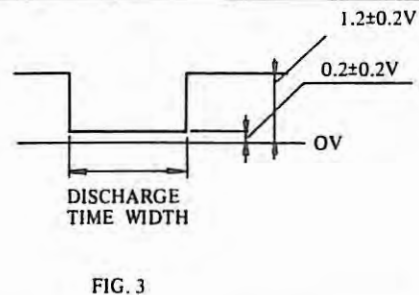
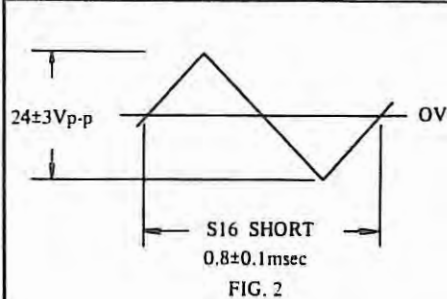

LED DISPLAY

NAME	MEANING
PRDY (GREEN LED)	POSITION READY SIGNAL.
VccRDY (GREEN LED)	MONITORING FOR BREAKING OF FUSE RESISTORS (R81, R82). LIGHTING : NO-BREAKING NO LIGHTING : CHECK ITEM 1) CONTINUITY CHECK : R81, R82 2) PCB CN2 TO TRANSFORMER
BRK (RED LED)	NO FUSE BREAKER CUT OFF
HVAL (RED LED)	HIGH VOLTAGE ALARM POWER SUPPLY VOLTAGE IS TOO HIGH. DISCHARGE C.K.T. GOES WRONG. LOAD INERTIA IS TOO HIGH.
HCAL (RED LED)	HIGH CURRENT ALARM SHORT C.K.T. BETWEEN T1(5)(6) AND (7)(8). TRANSISTOR MODULE IS DAMAGED. PCB OF PWM C.K.T. GOES WRONG.
OVC (RED LED)	OVERCURRENT ALARM (SET RV3) MOTOR LOAD IS TOO HEAVY.
TGLS (RED LED)	MOTOR RUNAWAY ALARM VELOCITY FEEDBACK SIGNAL IS LOSED. MOTOR ARMATURE CONNECTION IS OFF.
DCAL (RED LED)	DISCHARGE ALARM ACCELERATION AND DECELERATION FREQUENCY IS TOO HIGH. REGENERATIVE ENERGY FROM MACHINE WEIGHT OF VERTICAL AXIS IS TOO LARGE. TRANSISTOR FOR DISCHARGE IS DAMAGED.
LVAL (RED LED)	POWER SUPPLY VOLTAGE DROP ALARM. POWER SUPPLY VOLTAGE IS TOO LOW. FAULTY PCB.

6.3 Setting and adjustment for DC spindle servo unit PCB

6.3.1 Setting and adjustment for DC spindle servo unit (A20B-0008-0371 ~ 7)

(1) Mounting diagram

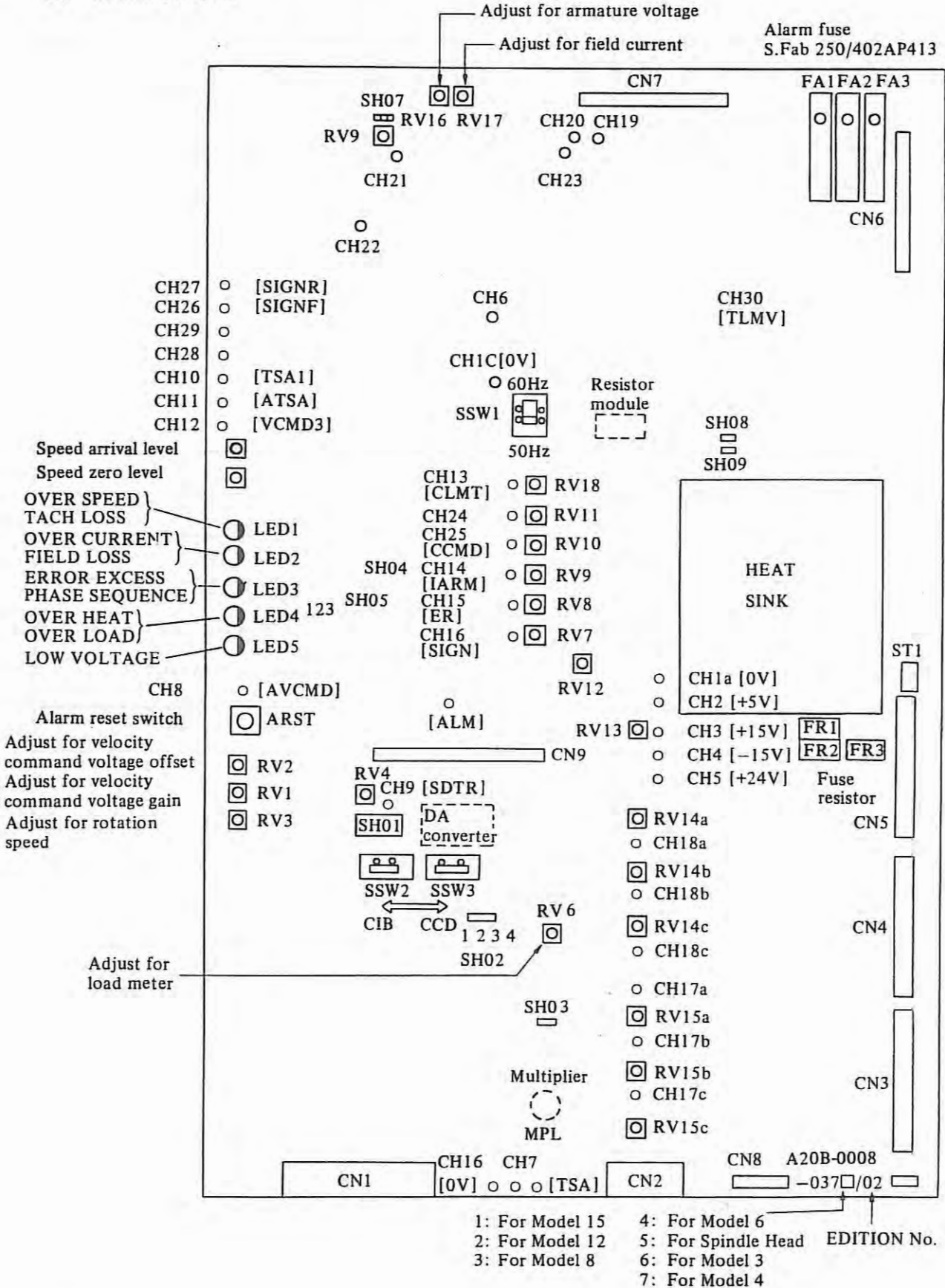

(2) List of check terminals

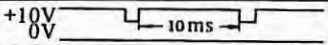
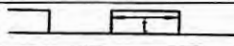
Name	Symbol	Signal name	Contents
TSA		Tacho-generator	Tacho-generator output is checked.
ALM		Alarm terminal	1 when alarm LED1, 2 or 3 lights
CH1a-c	0V	0V level	PC board 0V potential
CH2	+5V	+5V power supply	+5.0V \pm 3%
CH3	+15V	+15V power supply	+15.0V \pm 3%
CH4	-15V	-15V power supply	-15.0V \pm 3%
CH5	+24V	+24V power supply	+24V $\begin{matrix} +10\% \\ -15\% \end{matrix}$
CH6	Field Loss	Field loss alarm	1 at field loss
CH7	DAC OUTPUT	DA converter output voltage	10.0V at Full bits ON
CH8	AVCMD	External feed rate command voltage	Command from outside can be checked.
CH9	SDTR	Feed rate detection voltage	0.3V is set at for gear change.
CH10	TSA1	Normalized feed rate feedback voltage	\pm 10.0V at maximum number of revolutions
CH11	ATSA	Absolute value feed rate feedback voltage	+10.0V at maximum number of revolutions
CH12	VCMD3	Feed rate command voltage	0V \pm 10mV when there is no rotation command.
CH13	*CLMT	Current command limit voltage	-6.2V usually
CH14	IARM	Normalized current feedback voltage	\pm 4.0V (average value) at maximum current
CH15	ER	Phase angle command voltage	0.5-9.5V, approx. 2.7V (50Hz), approx. 4.0V (60Hz)
CH16	SIGN	Direction	+6.2V or -0.6V
CH17a-c	SYNCa-c	Synchronous signal	+10V 
CH18a-c	PHASE a-c	Firing angle display pulse	
CH19	FLDC	Field current feedback voltage	6.8A \Rightarrow -6.2V, 2.8V \Rightarrow -2.5V at stoppage
CH20	AV	Armature voltage feedback voltage	220V \Rightarrow -6.2V
CH21	FER	Field phase angle command voltage	0~6.8V
CH22	SYNCF	Field synchronous signal	Same as CH17
CH23	PHASEf	Field firing angle display pulse	Same as CH18
CH24	IARM	Current feedback voltage	Current value is known. 5mV/1AT.
CH25	CCMD	Current command voltage	\pm 8V at maximum command
CH26	*SIGNF	Forward gate release	Forward (F) thyristor ON at 0
CH27	*SIGNR	Reverse gate release	Reverse (R) thyristor ON at 0
CH28	USRF	Feed rate arrive level	1.5V = 15%
CH29	ZSRF	Zero feed rate level	75mV = 0.75%, 150mV = 1.5%
CH30	CCMD	Current command	\pm 2.6V = maximum current, check at torque limit

(4) Adjustment

No.	Trimmer	Item	Observation	Adjusting Standard	Standard (motor model)							○ : Necessary to adjust		
					15	12	8	6	Spindle Head	3	4	FANUC	Machine Tool Builder	User
1	RV1	Velocity command voltage gain	CH8	Full bits ON 10.0V	45 ~ 55%							Performed		
2	RV2	Velocity command voltage offset	CH8	Full bits OFF 0 ± 5 mV	50%							Performed		
3	RV3	Revolution speed	Motor or Spindle	Command and Revolution speed must coincide.	Max. 3,500 rpm				Max. 4,500 rpm				○	
4	RV4	Speed detecting level	CH9	Gear 0.3V Clutch 3.0V	0.3V 10%							Performed	If necessary ○	
5	RV6	Calibration of Load meter	LM	Continuous Rated: 5.0V	30 ? 40	45 ? 50	50 ? 55	40	45	35 ? 45	40	Performed		
6	RV7	Velocity loop offset	CH25	Motor doesn't rotate.	50 ~ 65%							Performed	If necessary ○	
7	RV8	Velocity loop gain		No vibration	70%				50%			Performed		
8	RV9	Torque limit	Motor current	Depends on machine	15A								If necessary ○	
9	RV10	Current detect offset	CH14	0 ± 20 mV	50 ~ 80%							Performed	Necessary when PCB is replaced. ○ ○	
10	RV11	Current limit setting	CH24	Depends on motor model	50%	62%	77%	25%	70%	42%	25%	Performed	Necessary when PCB is replaced.	
11	RV12	Current loop phase compensation			50 ~ 60%				30%			Performed		
12	RV13	Current loop gain			50%							Performed		
13	RV14 a,b,c	Adjustment of minimum pulse width	CH18 a,b,c	Short +15 and TSA 50Hz 1.0 ms 60Hz 1.2 ms								Performed		
14	RV15 a,b,c	Synchronous pulse balance	CH18 a,b,c	Vibration within ±0.1 ms	45 ~ 65%							Performed		
15	RV16	Armature voltage	A-H	at Max. speed wih within 220V DC	70 ~ 95%							Performed		

No.	Trimmer	Item	Observation	Adjusting Standard	Standard						○ : Necessary to adjust		
					15	12	8	6	Spindle Head	3	4	FANUC	Machine Tool Builder
16	RV17	Field current adjustment	Series to J	1000 rpm 6.8A	75 ~ 95%						Performed		
17	RV18	Output limit circuit	CH13	6.2V (standard)	100%						Performed		
				Use 1/2 output	10%								
18	RV19	Armature voltage clamp	A-H	AC 210V DC220V AC 200V DC 210V	35 ~ 45%						Performed		
19	RV20	Speed arrival detect level	CH28	(±15%) 1.5V (standard)							Performed	If necessary ○	
20	RV21	Speed zero detect level	CH29	0.75%	10 ~ 15%						Performed	If necessary ○	
				1.5% (150mV)						20 ~ 30%			

(5) Auxiliary check pin mounting diagram

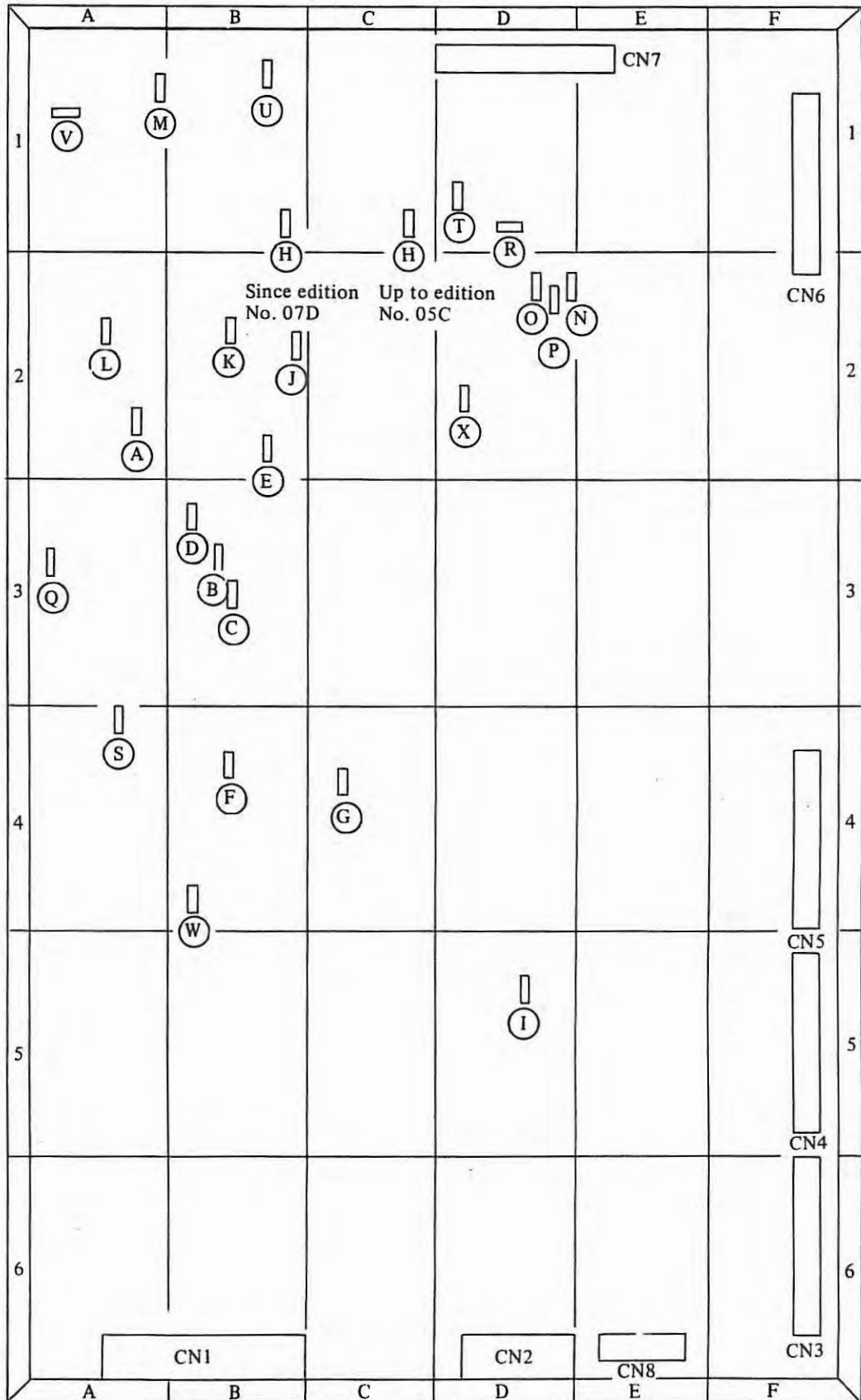

List of auxiliary check pin

(6) List of auxiliary check pin

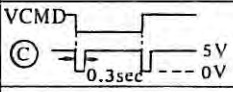
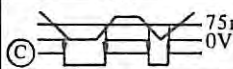
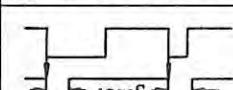
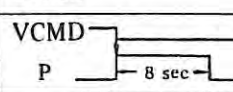
Mark	Position	Signal name	Contents	Remarks
A	A-2	Velocity error voltage	VCMD – TSA	
B	B-3	Velocity error excess	When VCMD – TSA is over 2V (or 5V), the level is high.	SH04 short 2V open 5V
C	B-3	Busy signal	When VCMD changes by over 0.7V, the level is low for 0.3 sec and returns to high.	
D	B-3	Speed zero	When rotation speed is below speed zero detection level (CH29 = 75mV), the level is low.	
E	B-2	Speed zero pulse	The level is held to low for a fixed time (approx. 40m sec) after the fall of speed zero signal and returns to high.	
F	B-4	Overspeed signal	When motor rotation speed is over 115% (11.5V) of maximum speed (10V), the level is high.	115% ± 5% (error)
G	C-4	Tacho-generator Loss Alarm	When speed feedback voltage is zero and armature voltage is over 145V, the level is high.	
H	C-1 B-1	Current zero	When armature current is below 18% (or 9%) of current limit value (4V), the level is low.	Models 3, 4, ... 18% Models 6, 8, 12, 15, 9%
I	D-5	10V reference Voltage	+10V ± 0.4V	
J	B-2	Enable signal	+0.4V at gate block, –15V at other time.	
K	B-2	Gate block	The level is low with MCC OFF, at alarm or at motor stoppage.	
L	A-2	Torque limit release condition	The level is low at speed zero with SFR and SRV OFF.	
M	A-1	Field weakening	The level is high when field is weakened.	
N	D-2	Clamp signal	+1.7V (during gate block) when both *SIGNF and *SIGNR are at high level, and –15V at other time.	
O	D-2	Phase limit signal	+1.7V until gate block signal is released after SIGN (CH16) is inverted, and –15V at other time.	+1.7V during current direction switch
P	D-2	Full power command	When VCMD changes by over 0.7V, the level is held to high for approx. 8 sec and returns to low.	
Q	A-3	Phase sequence alarm	The level is high at reverse phase or at missing phase.	
R	D-1	FLS ref. level	0.22V	
S	A-4	Speed arrival	When motor rotation speed is within a certain range (±15%) for command feed rate, the level is low.	
T	D-1	Over current	When armature current is over 190% (or 150%) of current limit value, the level is high.	Models 3, 4, ... 190% Models 6, 8, 12, 15, 150%

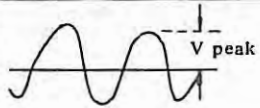
Mark	Position	Signal name	Contents	Remarks
U	B-1	Phase sequence a signal	$V_{\text{peak}} = 0.7\text{V}$ at normal time, $V_{\text{peak}} = 4.5\text{V}$ at missing W phase, and $V_{\text{peak}} = 8.5\text{V}$ at reverse phase (typical)	
V	A-1	Velocity error excess	When $ VCMD - TSA $ is over 0.5V at speed zero, the level is high.	
W	B-4	Speed detection signal	When motor rotation speed is below 3% (0.3V) of maximum speed at shipment, the level is high.	Standard setting at shipment time.
X	D-2	Field current	Waveform after CR filter is applied to field current (CH19) for approx. one sec.	

6.4 Setting and adjustment for AC spindle servo unit PCB

6.4.1 Mounting diagram of PCB

- Notes
- ⊙ Check Terminal (CH 1 to 32, etc.)
 - ⊞ Potentiometer (RV1 to 19)
 - ⊠ Terminal for setting (S1 to 7)

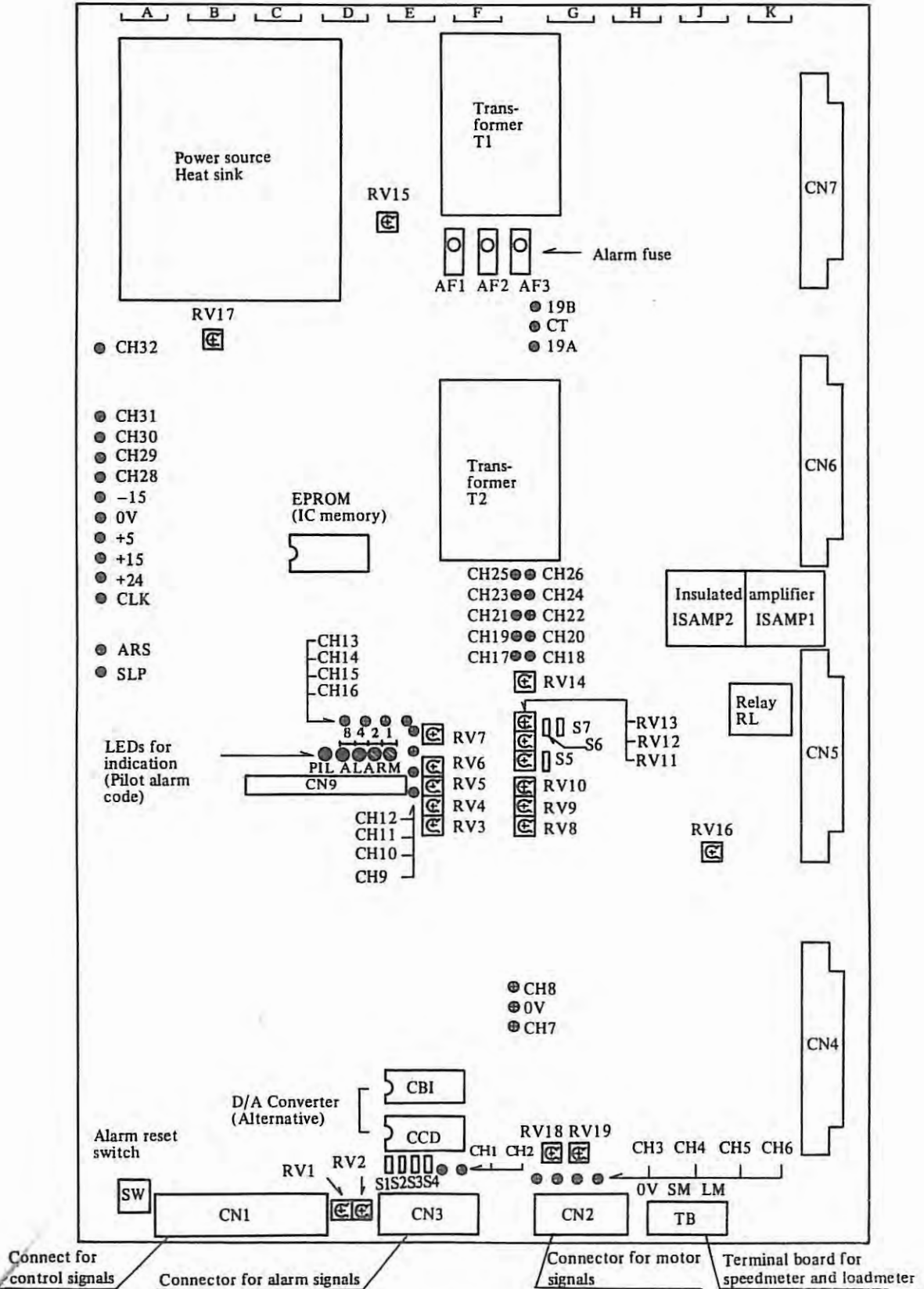

6.4.2 Main parts list

(1) Fuses and surge absorbers

Item	Symbol	Name	Specification				
			Model 3	Model 6	Model 8	Model 12	Model 15
1	F1 ~ 3	Fuse	A60L-0001-0127/25FH75		A60L-0001-0145	A60L-0001-0149	
2	F4	Fuse	A60L-0001-0031/5A				
3	F5, 6	Fuse	A60L-0001-0036/PC1-20		A60L-0001-0036/PC1-30		
4	F7	Fuse	A60L-0001-0147		A60L-0001-0145		A60L-0001-0149
5	Z1 ~ 4	Surge absorber	A50L-0221-0062/441-12				
6	AF1	Fuse on PCB	A60L-0001-0046/3.2 (3.2A)				
7	AF2, 3	"	A60L-0001-0075/3.2 (3.2AS)				

(2) Main parts

Item	Symbol	Name	Specification				
			Model 3	Model 6	Model 8	Model 12	Model 15
1	P.C.B.	Printed circuit board	A20B-0009-0530	A20B-0009-0531	A20B-0009-0532	A20B-0009-0533	A20B-0009-0534
2	ROM	Memory element	J10	J11	J02	J03	J04
3	TM1 ~ 11	Transistor module	A50L-0001-0096				
4	SM1 ~ 3	SCR module	A50L-5000-0029/30		A50L-5000-0029/50		
5	DM1 ~ 3	Diode module	A50L-2001-0138		A50L-2001-0146		
6	D1 ~ 3	Diode	A50L-2001-0103/12JH11				
7	D4 ~ 6	Diode	A50L-2001-0103/12JG11				
8	D7	Diode	A50L-2001-0081/60				
9	D8	Diode	A50L-2001-0097/U06G				
10	C1 ~ 3	Capacitor	A42L-0001-0103				
11	MCC	Electromagnetic contactor	A58L-0001-0094/200V1A1B		A58L-0001-0092/A		
12	TF	Transformer	A80L-0001-0276				
13	FAN	Cooling fan	A90L-0001-0099/A				
14	TH	Thermostat	A57L-0001-0028				
15	SW	Switch	A57L-0001-0030/2				

6.4.3 Adjustment of potentiometers on PCB

Notes 1. This table is applicable to PCBs of versions
A20B-0009-0530 to 0534.

2. Since the potentiometers, RV7, 8, 14 through 19, are adjusted by FANUC at shipment, they must not be readjusted by the user.

No.	Symbol	Item	Standard setting	Check terminals	Procedure
1	RV1	Velocity command voltage level		CH13-0V	See Subsection (1) on the next page.
2	RV2	Velocity command voltage offset		CH13-0V	See Subsection (1) on the next page.
3	RV3	Speed arrival detection level		CH10-0V	See subsection (4)
4	RV4	Speed detection level		CH9-0V	See subsection (5)
5	RV5	Torque limitation level			See subsection (6)
6	RV6	Regenerated power limitation	3 scale		See item 5.1.5.
7	RV7	VF conversion level (1)		CH23-0V	When the voltage between LM and OM is 10V, the frequency is 200 ± 2 kHz.
8	RV8	Setting for speed detection circuit		CH18-0V	When the voltage between CH17 and 0V is 0.2V, 2.2 ± 0.1 V.
9	RV9	Adjustment of forward motor speed		Number of motor revolutions	See Subsection (2) on the next page.
10	RV10	Speed detection offset		CH17-0V	When the spindle is stopped, the offset voltage must be within ± 2 mV.
11	RV11	Adjustment of reverse motor speed		Number of motor revolutions	See Subsection (2) on the next page.
12	RV12	Velocity loop gain	5 scale		
13	RV13	Velocity loop offset		Spindle	See Subsection (3) on the next page.
14	RV14	Adjustment of loadmeter amplitude		LM-0M	10 ± 0.1 V at acceleration (without torque limit)
15	RV15	Voltage adjustment of +5V		+5V-0V	5 ± 0.05 V
16	RV16	Regenerated voltage limitation level	4 scale		
17	RV17	VF conversion level (2)		CH32-0V	When input voltage is 200V AC, the frequency is 24 ± 0.2 kHz.
18	RV18	Adjustment of RA offset		CH5-0V	2.5 ± 0.05 V in the state that CN2 is open.
19	RV19	Adjustment of RB offset		CH6-0V	Same as the above.

(1) Velocity command voltage (RV1, RV2)

When the velocity command voltage is 10V, the motor rotates at the rated speed.

Item	Measuring terminals	Adjustment procedure
Offset	CH13-0V	Set the motor in operating status and supply a velocity command voltage of 0V (equivalent to S00) to the motor. Adjust RV2 so that the voltage between the measuring terminals will not change when forward rotation and reverse rotation commands are issued alternately. See the following NOTE.
Level	CH13-0V	Next, supply a rated rotational command voltage of 10V to the motor, and adjust RV1 so that the voltage between the measuring terminals becomes $+10V \pm 0.05V$ when the spindle forward rotation command is issued.

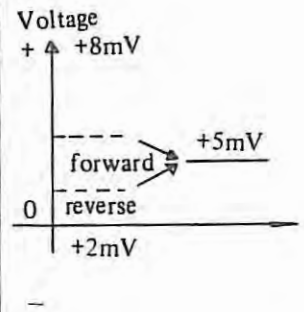

(NOTE) For example, if the voltage at CH13 is $+5.0mV$ when the spindle rotates forward and it is $+5.0 mV \pm 1.0 mV$ when the spindle rotates in reverse, the offset error of the velocity command voltage is $\pm 1.0 mV$.

(2) Rotational speed adjustment (RV9, RV11)

The number of motor revolutions can be adjusted accurately by the following procedure. At this time, the number of motor revolutions should be measured directly using a stroboscope or tachometer.

Item	Measuring point	Adjusting procedure
Number of forward motor revolutions	Spindle	Supply the rated velocity command voltage to the motor. Adjust RV9 so that the motor rotates at the rated speed when a forward rotation (SFR) command is issued.
Number of reverse motor revolutions	Spindle	Adjust RV11 so that the motor rotates at the rated speed when a reverse rotation (SRV) command is issued.

(NOTE) The forward rotation means that the AC spindle motor rotates counterclockwise (forward rotation) as seen from the shaft. Thus, it may not correspond to the forward rotation of the machine spindle.

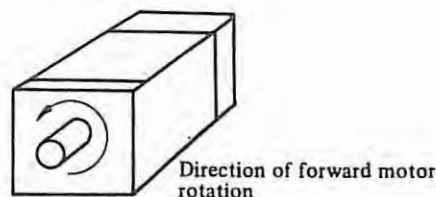

(3) Velocity offset (RV13)

This adjustment is made so that the spindle will not rotate at low speed when a velocity command voltage of 0V is supplied. This should be performed after the previous adjustments.

Item	Measuring point	Adjusting procedure
Velocity offset	Spindle (or Motor)	Supply a velocity command voltage of 0V. Adjust RV13 so that the spindle will not rotate when forward or reverse rotation commands are issued.

(4) Speed arrival detection level (RV3)

Setting of the speed arrival detection level can be performed by using the following graph.

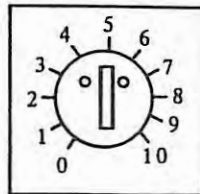
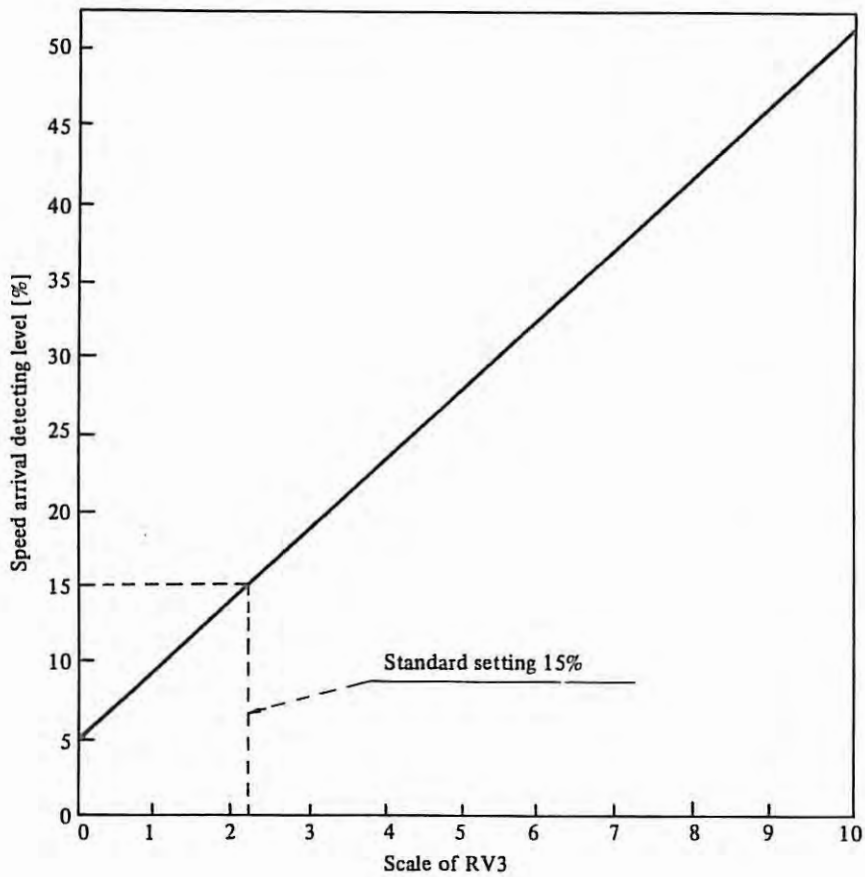

How to read the scale of potentiometer

(5) Speed detecting level (RV4)

Vertical axis is the percentage of motor speed when rated value is assumed as 100%. This signal can be used for confirmation when clutch or gear is being changed.

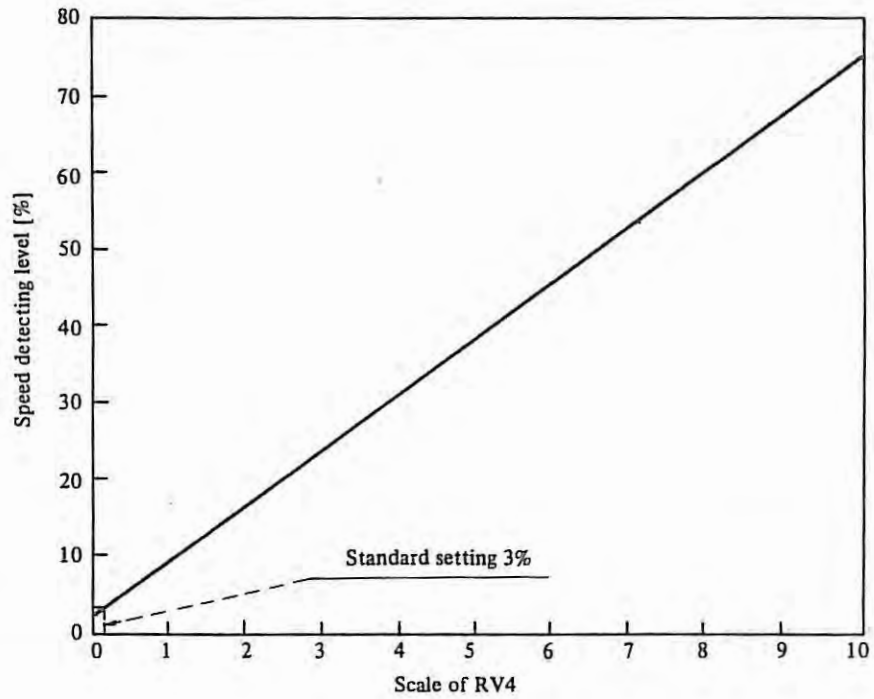

(6) Torque limit level (RV5)

Vertical axis is the percentage of torque when 30 minutes rated torque is assumed as 100%.

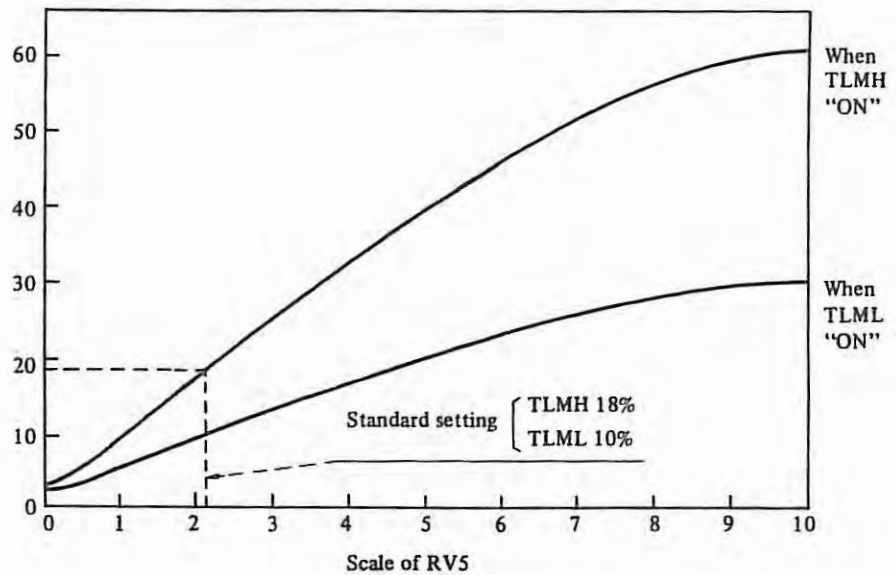

6.4.4 Description of check terminals

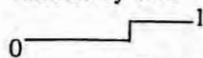
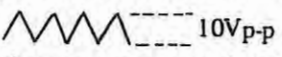
Terminal name	Signal name	Contents	Remarks								
CH1	DA2	Analog command voltage	0 ~ 10.0V								
CH2	DA1	Output voltage from D/A converter	0 ~ 10.0V								
CH3	PA	Phase A output from pulse generator	$(2.5V \pm 5\%) \pm 0.2V_{TYP.}$								
CH4	PB	Phase B output from pulse generator	PA leads PB by 90° when CW rotation								
CH5	RA	Reference voltage of phase A	Direct current of PA: ± 25 mV								
CH6	RB	Reference voltage of phase B	Direct current of PB: ± 25 mV								
CH7	PSA	Phase A square wave	Duty 50% (at constant speed) $\pm 10\%$								
0V	0V	0V of printed circuit board									
CH8	PSB	Phase B square wave	Duty 50% (at constant speed) $\pm 10\%$								
CH9	SDTRF	Speed detection level	Variable 0.14V through 7.4V by RV4								
CH10	SARRF	Speed arrival level	Variable by RV3'								
CH11	BUZY	Acceleration/deceleration busy	 1: During Acc/Dcc								
CH13	VCMD	Velocity command voltage	0 ~ $\pm 10.0V(\oplus)$; CCW, \ominus CW								
CH14	RVP	Reverse rotation speed pulse	Pulse width: 3.2 microseconds (Only for reverse rotation)								
CH15	FWP	Forward rotation speed pulse	Pulse width: 3.2 microseconds (Only for forward rotation)								
CH16	0V	0V of printed circuit board									
CH17	TS1	F/V output of velocity feedback	6000 rpm (CCW): -10V								
CH18	TS2	Low speed detection signal	120 rpm (CCW): -2.2V								
CH20	TSA	Velocity feedback signal	Rated rotational speed: $\pm 10V$, CCW: \ominus								
CH21	LTRF	Output torque limitation voltage	Output = $-[(V_{CH21} + 1.8)/10]$ X Maximum output								
CH22	CRU	Phase U current detection signal	Current per 1V <table border="1" data-bbox="870 1372 1193 1462"> <tr> <td>M3, 6</td> <td>M8</td> <td>M12</td> <td>M15</td> </tr> <tr> <td>16.7A</td> <td>25A</td> <td>35.7A</td> <td>50A</td> </tr> </table>	M3, 6	M8	M12	M15	16.7A	25A	35.7A	50A
M3, 6	M8	M12	M15								
16.7A	25A	35.7A	50A								
CH23	ERP	VF conversion output	CH28 10V: 20 kHz, width; 0.4 μ s								
CH24	CRV	Phase V current detection signal	V phase motor current detection signal								
CH25	TRWF	Triangle wave signal	 10V _{p-p}								
CH26	CRW	Phase W current detection signal	W phase motor current detection signal								
CLK	CLK	Clock signal	312.5 kHz 200 ns typ								
+24	24V	Power source voltage of +24V	DC 25.6 V _{typ} , Ripple: 0.5V _{p-p} 100 Hz								
+15	15V	Power source voltage of +15V	-15V $\pm 4\%$								
+5	5V	Power source voltage of +5V	+5V $\pm 1\%$ (Preadjusted by RV15)								
0V	0V	0V of printed circuit board	0V, same as CH16								
-15	-15V	Power source voltage of -15V	-15V $\pm 4\%$								

Terminal name	Signal name	Contents	Remarks
CH28	ER	Error voltage	0 – 10V
CH29	UCM	Phase U command voltage	
CH30	VCM	Phase V command voltage	
CH31	WCM	Phase W command voltage	
CH32	24VP	Pulse signal	24KHz at AC200V
19A	19A	Input voltage of 19V AC	Control power supply
CT	CT	0V	"
19B	19B	Input voltage of 19V AC	"

6.5 Adjustment of spindle orientation

6.5.1 For magnetic sensor system

(1) Mounting magnetizing element and magnetic sensor

Determine the mounting direction for the magnetizing element and magnetic sensor as follows. Incorrect mounting may cause repeating of clockwise and counterclockwise rotation of spindle without stopping during positioning, hunting, and the end of the magnetizing element and sensor head to stop in the opposite position.

Mounting magnetizing element and sensor

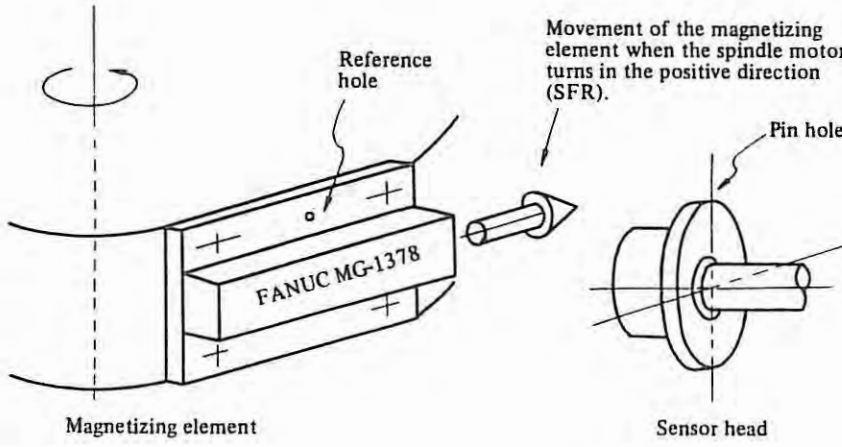
Item	Explanation
1	Mount the magnetizing element so that the reference hole moves and faces as shown in Figure 1 when the spindle rotates in the positive direction by the command of spindle motor CW rotation (SFR and VCMD positive).
2	Mount the magnetic sensor head so that the pin hole of the flange and the reference hole of the magnetizing element face in opposite directions.
3	The gap between the magnetizing element and sensor head should be a minimum of 1.5 ± 0.5 mm.
4	 <p style="text-align: center;">Figure 1 Mounting magnetizing element</p>

(2) Setting and adjustment of two speed steps type

Spindle orientation circuit C A06B-6041-J120
 Orientation circuit C PCB A20B-0008-0030

(a) Setting and function of jumper terminal (SH)

The connection and function of jumper terminals (SH) which can be freely selected, are listed below. SH01 should be connected after the power is on since it is used only for adjustment and testing. It should be disconnected after adjustment making sure that LED7 goes off.

Connection and functions of jumper terminals (SH)
 (A double outline indicates the standard setting)

(Note 1) Status			Function	Remarks
SH	1-2	2-3		
01	/	○	Test mode (Note 2)	Connected only for adjustment.
02	○	×	When an orientation instruction is issued after power is turned on and before driving the spindle, the motor shaft end rotates in a clockwise direction.	The setting on SH03 takes priority of the setting on SH02. The setting on SH02 is effected only when SH03 1-2 is connected.
	×	○	When an orientation instruction is issued after power is turned on and before driving the spindle, the motor shaft end rotates in a counterclockwise direction.	
03	○	×	Moves in the direction the spindle was turning just before the orientation instruction was issued.	The setting on SH02 becomes effective.
	×	○	The orientation direction is always CCW.	
	×	×	The orientation direction is always CW.	
04	×	×	Initial orientation speed is about $60 \times$ [spindle position loop gain s^{-1}] r.p.m. of the spindle. (usual rate)	Since spindle position loop gain is generally close to 5 sec.^{-1} , the usual rate is about 300 r.p.m.
	○	×	The initial rate of speed is limited to 1/3 the usual rate.	
	×	○	The initial rate of speed is limited to 2/3 the usual rate.	

Notes: (1) ○ indicates connected, × indicates not connected.

(2) When in Test Mode

- (a) The orientation instruction is issued.
- (b) Orientation end signal (ORAR 1,2) is not transferred.
- (c) The spindle turns at the initial speed while SW1 (INITIALIZING BUTTON) is pressed. When it is released, the spindle stops at a fixed position.
- (d) The red light emitting diode (LED 7) is on in this mode.

(b) LED indicators

Seven display lamps (LED 1 – 7), indicating the meanings listed below, are mounted on this option board. (LED 1 and LED 2 are not mounted on board 01A.)

LED indicators

LED	Meaning	Color	Explanation
1	ORIENTATION	Green	Lights during execution of an orientation instruction. (ORCM 1 and 2 are connected: ON)
2	CLUTCH (gear) LOW	Green	Lights when the clutch (gear) LOW signal is on. (*CTH 1 and 2 are connected: ON)
3	MS PEAK LEVEL	Green	Lights while the peak value of the magnetic flux detection signal (MS) is out of the range of $\pm 10V$. Adjustment indicator.
4	SLOWDOWN PERIOD	Green	Lights during the low turning speed period when the spindle position approaches the stop position during orientation.
5	IN-POSITION FINE	Green	Lights when the value of MS output approaches within $+0.1^\circ$ of the spindle angle. Sometimes lights when the sensor is not on the magnetizing element.
6	IN-POSITION	Green	Lights when orientation has been completed and the spindle is within $\pm 1^\circ$ of the adjustment position. When it lights while not in TEST MODE, the Orientation Completion signal is transmitted. (ORAR 1 and 2 are connected: ON)
7	TEST MODE	Red	Lights when SH01 pins are connected. In this mode, the Adjustment Completion signal is not transmitted and ORCM is on. The orientation motion can be repeatedly confirmed by pressing SW1.

(c) Potentiometer (POT) setting

Set the POT according to the following values followed by table before orientation adjustment. * will be reset at a later stage.

Potentiometer settings

POT name	RV	1*	2*	3	4	5	6*	7*	8	9*	10*	11*
POT scale position		5.0	6.0	①	①	②	2.0	5.0	③	2.0	5.0	5.0

① RV3 and RV4 settings

Set RV3 and RV4 according to the distance H between the turning axis of the magnetizing element and the center of the sensor head.

H (mm)	60 ~ 65	~70	~75	~80	~85	~90	~95	~100	~105	~110
Scale position	7.0	6.0	5.0	4.0	3.0	2.5	2.0	1.5	1.0	0.5

② RV5 setting

Set RV5 according to the number of revolutions (N_{HM}) when the spindle rotates at rated speed.

N_{HM} (rpm)	2,000 ~ 2,200	~ 2,500	~ 2,700	~ 3,100	~ 3,500	~ 4,000	~ 4,500	~ 5,000	~ 5,500	~ 6,000
Scale position	7.5	6.5	5.5	4.5	3.5	2.5	2.0	1.5	1.0	0.5

③ RV8 setting

Set RV8 according to the transmission ratio of $R_{H/L}$ of spindle HIGH/LOW.

$R_{H/L}$	~2.0	~2.2	~2.5	~2.8	~3.2	~3.7	~4.4	~5.3	~6.0	~7.0
Scale position	2.0	3.0	4.0	5.0	6.0	7.0	8.0	9.0	9.5	10

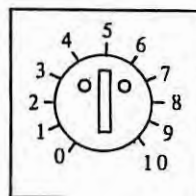

Scale of potentiometer

(d) Potentiometer adjustment

Adjust RV1 ~ RV11 according to the following table. Adjustment of orientation PCB must be performed after the adjustment of spindle control PCB. Orientation position may be shifted if the adjustment of RV12 or RV13 on spindle control PCB is altered.

Potentiometer adjustment

The following adjustments should be performed in Test Mode by connecting SH01 pins.

Term	POT name	Adjustment purpose	Condition	Adjustment method (Specification)
1	RV1	TS OFFSET	The spindle should be stopped.	Voltage across check 15 (TSA2) and 16 (0V) should be within ± 1.0 mV.
2	RV2	MS PEAK LEVEL	Keep pressing SW1 (INITIALIZING BUTTON)	Adjusted position until LED3 (MS PEAK LEVEL) begins to light.
3	RV3	SLOWDOWN REFERENCE		According to the setting terms.
4	RV4	AMS PEAK LEVEL		According to the setting terms.
5	RV5	SLOWDOWN TIME IN HIGH MODE	Clutch (gear) is HIGH. Press SW1 to stop the spindle at the fixed position. The *CTH signal is off (open).	Just before stopping LED4 (SLOW DOWN PERIOD) should immediately light up clearly.
6	RV6	GAIN [H]	Clutch (gear) is HIGH. Press SW1 to stop the spindle at the fixed position. The *CTH signal is off (open).	Turn in the CW direction being careful not overshoot when stopping.
7	RV8	IN-POSITION	Clutch (gear) is HIGH. Press SW1 to stop the spindle at the fixed position. The *CTH signal is off (open).	LED5 (IN-POS. FINE) should light while LED 6 (IN-POSITION) is on.
8	RV8	SLOWDOWN TIME IN LOW MODE	Clutch (gear) is LOW. Press SW1 to stop the spindle at the fixed position. The *CTH signal is on (closed).	LED4 (SLOWDOWN PERIOD) should immediately light up clearly just before stopping. (See term 5)
9	RV9	GAIN [L]	Clutch (gear) is LOW. Press SW1 to stop the spindle at the fixed position. The *CTH signal is on (closed).	Turn in the CW direction being careful not to overshoot when stopping.
10	RV10	IN-POSITION [L]	Clutch (gear) is LOW. Press SW1 to stop the spindle at the fixed position. The *CTH signal is on (closed).	LED 5 (IN-POS. FINE) should be on when LED 6 (IN-POSITION) is on.

Term	POT name	Adjustment purpose	Condition	Adjustment method (Specification)
11	RV11	POSITION SHIFT		The stop position can be finely adjusted to within $\pm 1^\circ$ of the spindle angle.

After adjustment, release Test Mode making sure that LED 7 (Red) is off.

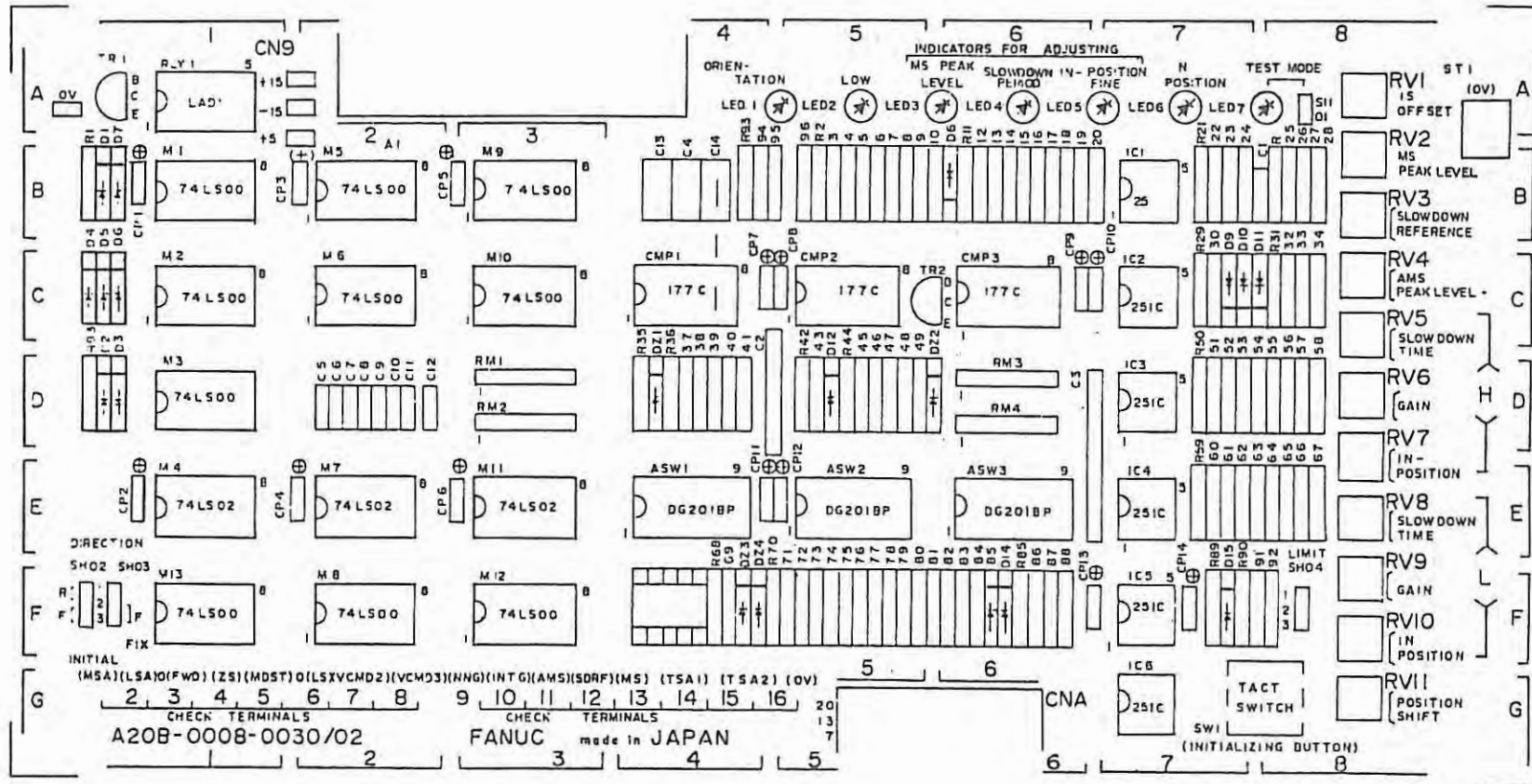

Parts mounting diagram

Location of check terminals and potentiometers.

(3) Setting and adjustment of three speed steps type

Orientation circuit D A06B-6041-J121

Orientation circuit D

PCB drawing number A20B-0009-0520

The spindle speed range is as listed below.

	Spindle speed range
High	4000 – 8000 rpm
Medium	1000 – 2000 rpm
Low	250 – 667 rpm

(a) Setting and function of jumper terminal (SH)

See 2.2.1.

(b) LED indicators

LED No.	Meaning	Color	Contents
LED1	ORIENTATION	Green	Lights during execution of an orientation command.
LED2H	GEAR/CLUTCH	Green	Lights when the gear/clutch is shifted to high position.
LED2M			Lights when the gear/clutch is shifted to middle position.
LED2L			Lights when the gear/clutch is shifted to the low position.
LED3	MS PEAK LEVEL	Green	Lights when the peak value of the MS signal sent from the magnetic sensor is out of the range of $\pm 10V$.
LED4	SLOWDOWN PERIOD	Green	Lights during low turning speed and goes out when the magnetizing element reaches the sensor.
LED5	IN-POSITION FINE	Green	Lights when orientation has been completed and the spindle is within $\pm 0.1^\circ$ of the adjustment position.
LED6	IN-POSITION	Green	Lights when orientation has been completed and the spindle is within $\pm 1^\circ$ of the adjustment position. When it lights while not in TEST mode, the orientation completion signal is transmitted.
LED7	TEST MODE	Red	Lights when terminals 01 and 02 of SH01 are shorted.

(c) Adjustments

The following adjustments should be performed in TEST mode after turning on the power.

Item	Variable resistor	Adjustment item	Condition	Adjustment procedure
1	RV1	TSA OFFSET Tachogenerator offset	The spindle should be stopped.	Voltage across check terminals CH1 5 (TSA2) and 16 (0V) should be within 0 ± 1.0 mV.
2	RV2	MS PEAK LEVEL Amplitude adjustment of MS signal	SW1 should be kept pressed.	Adjust the position until LED3 begins to light.
3	RV3	SLOWDOWN REFERENCE Setting of the slowdown level	Measure the distance from the center of the spindle to the sensor head	See NOTE 1.
4	RV4	AMS PEAK LEVEL Amplitude value of AMS signal		
5	RV5	SLOWDOWN TIME Adjusting slowdown time	Shift the gear to the HIGH position and LED2H goes on. Turn SW1 on and off repeatedly.	Just before stopping, LED4 should immediately light up clearly (about 0.2 sec.)
6	RV6	GAIN [HIGH] Position loop gain		Turn clockwise to increase the gain being careful not to overshoot when stopping.
7	RV7	IN-POSITION [H] Adjusting the spindle stop position		Adjust so that LED5 lights while LED6 is on. LED5 may flicker.
8	RV8	SLOWDOWN TIME [LOW] Adjustment of slowdown time	Shift the gear to the LOW position and LED2L goes on. Turn SW1 on and off repeatedly.	Same as item 5 above.
9	RV9	GAIN [LOW] Position loop gain		Same as item 6 above.
10	RV10	IN-POSITION [LOW] Adjusting the spindle stop position		Same as item 7 above.
11	RV11	SLOWDOWN TIME [MEDIUM] Adjusting slowdown time	Shift the gear to the MEDIUM position and LED2M goes on. Turn SW1 on and off repeatedly.	Same as item 5 above.
12	RV12	GAIN [MEDIUM] Position loop gain.		Same as item 6 above.
13	RV13	IN-POSITION [MEDIUM] Adjusting the spindle stop position		Same as item 7 above.
14	RV14	POSITION SHIFT Shifting of spindle stop position	The stop position can be finely adjusted within a range of $\pm 1^\circ$ of the spindle angle.	Match the key position of the ATC arm to the groove position of the spindle.

After adjustment, release test mode making sure that LED7 (Red) is off.

(NOTE 1) Adjust RV3 and RV4 based on the distance (Hmm) from the center of the spindle to the sensor as listed below.

H (mm)	50	60	70	80	90	100	110	120
Position RV3, 4	9.5	6.5	4.5	3.0	2.2	1.5	1.0	0.5

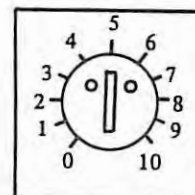

Scale

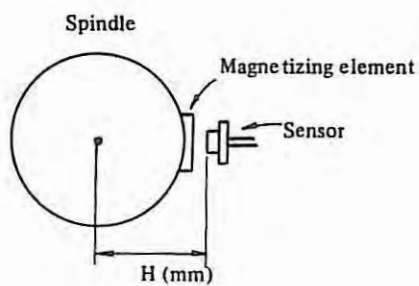

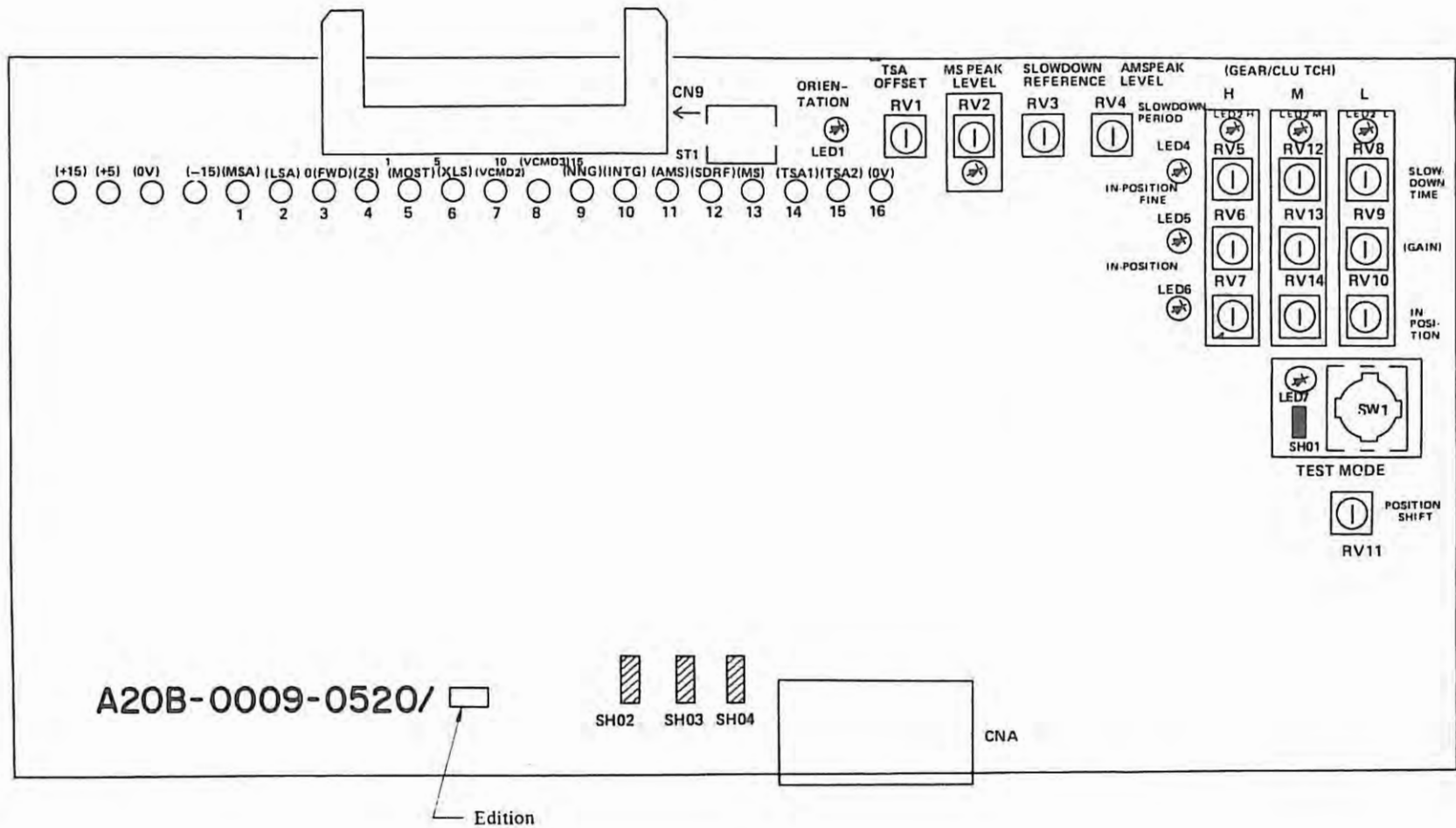

Location of check terminals and potentiometers.

(4) Confirmation of the spindle position loop gain

The spindle position loop gain should be tested after orientation stop control circuit adjustment by using the procedure outlined in the next table.

Spindle position loop gain	
Procedure	
1	Connect SH01 pins, to enter Test Mode (LED7 goes on).
2	Disconnect SH04 1-2 and 2-3 pins to remove limits.
3	Measure the number of spindle revolutions $N_{S(H)}$ and $N_{S(L)}$ (r.p.m) when SW1 (INITIALIZING BUTTON) is on, for each of the following condition. Spindle clutch (gear) HIGH (*CTH1 and 2 not connected) Spindle clutch (gear) LOW (*CTH1 and 2 connected)
4	The spindle position loop gain can be determined using the following equations: $K_{p(H \text{ or } L)} = N_{s(H \text{ or } L)} \div 55 (\text{sec}^{-1}), \text{ where}$ $K_{p(H)} : \text{ Position loop gain for spindle HIGH gear (clutch)}$ $K_{p(L)} : \text{ Position loop gain for spindle LOW gear (clutch)}$

6.5.2 For position coder system

(1) Printed circuit board

Spindle control circuit A20B-0009-0530 ~ 0534

Position coder method spindle orientation control circuit

- (a) Stop position internal setting A20B-0008-0240
- (b) Stop position external setting A20B-0008-0241

(2) Display

Light emitting diode

- LED1 ORIENTATION Lights when orientation command (ORCM1, 2 ON) is issued.
- LED2 LOW Lights when the contact of clutch change signal *CTH is closed. Lighting indicates that clutch LOW is selected.
- LED3 IN-POSITION OUT Lights when orientation completion signal ORAR 1-2 is issued.
- LED4 IN-POSITION ADJUST Lights when spindle enters within one pulse of orientation position.
Stop position can be the same at HIGH and LOW by adjusting POT RV3/RV5 for OFFSET adjustment so that this LED lights at gear HIGH/LOW.

(3) Setting

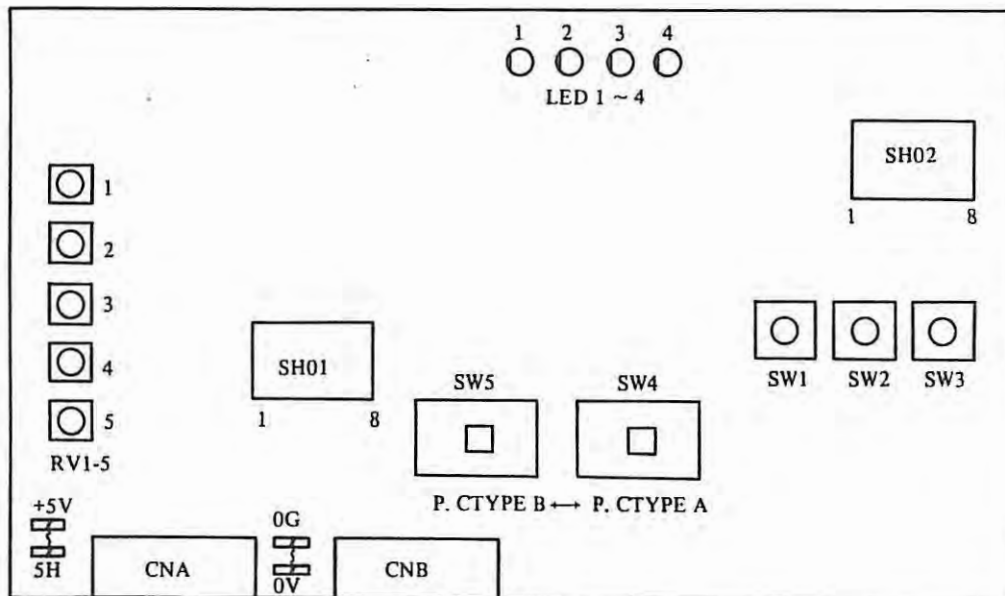

- (a) +5V -5V When the power of +5V for position coder is supplied from spindle amplifier, connect
0G -0V between +5V and 5H and between 0G and 0V. When the power of +5V is supplied from
NC, open between +5V and 5H and between 0G and 0V.

- (b) Setting of SW5 and SW4

Position coder	Type	SW4	SW5
Balanced type	Type A	Right	Right
Unbalanced type	Type B	Left	Left

- (c) Setting of SH01 and SH02

Follow the next table.

Table 1 Setting of SH01, SH02

○: Connected X: Open

No.	Contents		SH01								SH02								Remarks		
			1	2	3	4	5	6	7	8	1	2	3	4	5	6	7	8			
			16	15	14	13	12	11	10	9	16	15	14	13	12	11	10	9			
1	Initial orientation direction immediately after turning on power	CCW	○	X																(Standard)	
		CW	X	○																	
2	Orientation direction after initial orientation	CCW only			X	○														(Standard)	
		CW only			X	X															
		Spindle rotational direction			○	X															(Standard)
3	Orientation speed which is set by position gain	1				X	X														
		2/3				○	X														
		1/3				X	○														
4	Rotational direction of spindle and position coder	Same direction							○	X										Different from machine tool to machine tool. Incorrect setting will cause hunting.	
		Reverse direction							X	○											
5 (Note)	In-position width to issue orientation completion signal (ORAR 1, 2)	±2 pulses									○	○	○	○	○	○				±16 pulses correspond to ±1.3°	
		±4 pulses										○	○	○	○	○					
		±8 pulses											○	○	○	○					
		±16 pulses												○	○	○					
		±32 pulses													○	○					
		±64 pulses														○					
6	Setting due to position coder hysteresis	No pulse															X	X	(Standard)		
		+1 pulse															○	X			
		-1 pulse															X	○			

(Note) The condition (c) of issue of orientation completion signal
 c = (Spindle is within the in-position width) and (Velocity zero signal is ON) and (ORCM is ON)

(d) Setting of stop position SW1, 2, 3

Switch	Contents
SW1 (16 positions)	1 position is $4096/16 = 256$ pulses, equivalent to 22.5° .
SW2 (16 positions)	1 position is $256/16 = 16$ pulses, equivalent to 1.4° .
SW3 (16 positions)	1 position is $16/16 = 1$ pulse, equivalent to 0.088° .

An arbitrary position in a rotation can be positioned by the unit of $0.088^\circ = 1/4096 \times 360^\circ$ by setting in the order of SW1, 2 and 3.

(4) Adjustment

No.	Item	Variable resistor	Measuring point	Standard Adjustment	Note
1	Velocity feedback offset	RV1	TSA2 CH14	5 scale	The voltage at TSA2 should be ± 1 mV.
2	Position gain at gear High	RV2	Do not let spindle overshoot	3~4 scale	
3	Offset at gear High	RV3	Let LED4 ADJUST light	About 5 scale	Gleaming of the LED is sufficient.
4	Position gain at gear Low	RV4	Do not let spindle overshoot	3~6 scale	
5	Offset at gear Low	RV5	Let LED4 ADJUST light	About 5 scale	

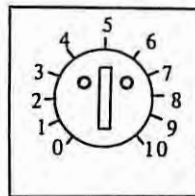

Scale of potentiometer

APPENDIX

Appendix 1 Connection Diagram

1. Total Connection Diagram

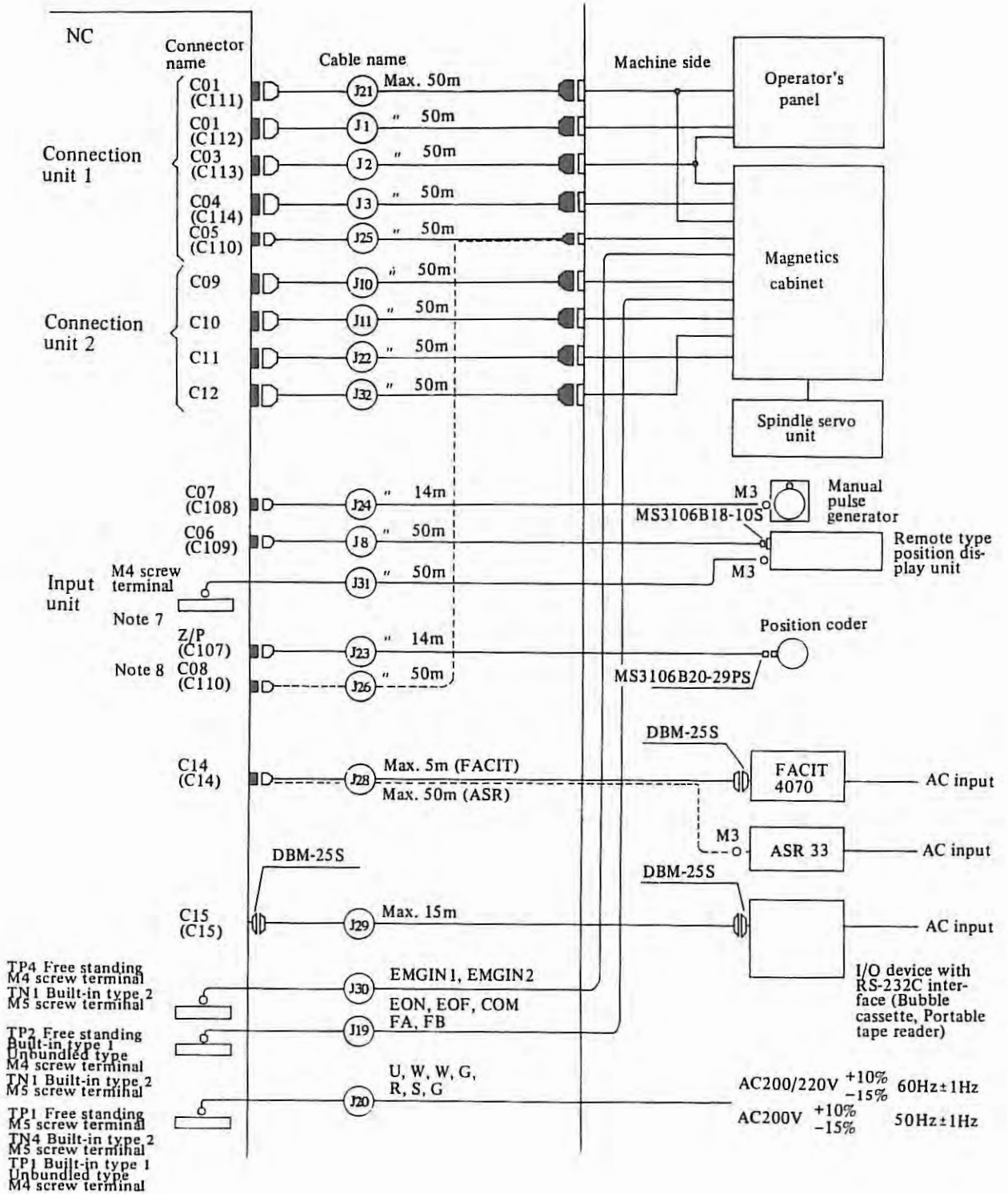

- Notes:
1. Cables and the connectors attached to them are not included in the NC basic control unit.
 2. When designing the machine side circuit, be sure that wires connected to the NC are separated from wires connected other units. A spark killer must be attached to an inductive load such as electromagnetic contactors in the electric circuit of the machine side.
 3. Use shielded wire for cables J23 ~ J29. These cables must also be shielded on the machine. The shield must not be connected to the ground on the machine tool.
 4. The connector names in parentheses are for Built-in type 2 cabinet.
 5. When T or C axis is equipped with, the connector for position coder is C19.
 6. When T or C axis is equipped with, the connector for S analog output is C18.
 7. The symbols of connectors represent as follows, if not specified otherwise.

- | | | | | | |
|---|---|----------------------|---|---|----------------------|
| ■ | ▣ | HONDA 50 pins male | □ | ▤ | HONDA 50 pins female |
| ■ | ▣ | HONDA 20 pins male | □ | ▤ | HONDA 20 pins female |
| ○ | | Crimp style terminal | | | |

8. When a cable more than max. length shown above diagram needs to use, consult us beforehand.
9. The connection between external MDI & CRT, external connection unit and NC should be made as follows:
 - (i) When external MDI & CRT unit is connected at the end.

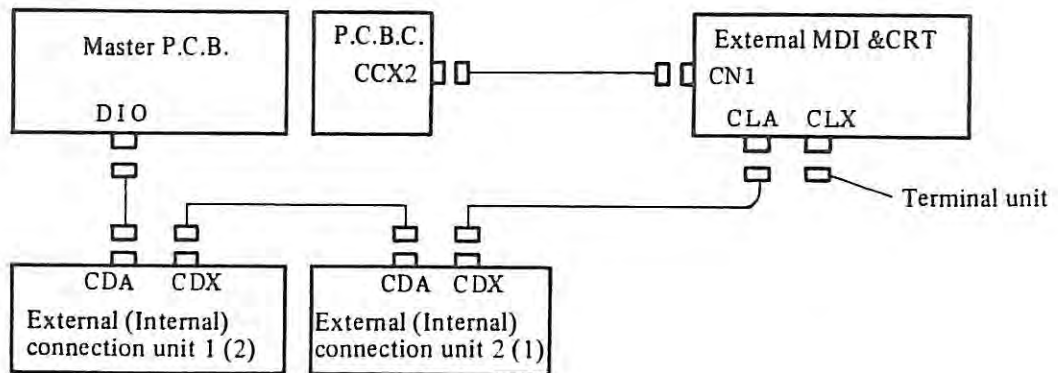

- (ii) When external connection unit is connected at the end.

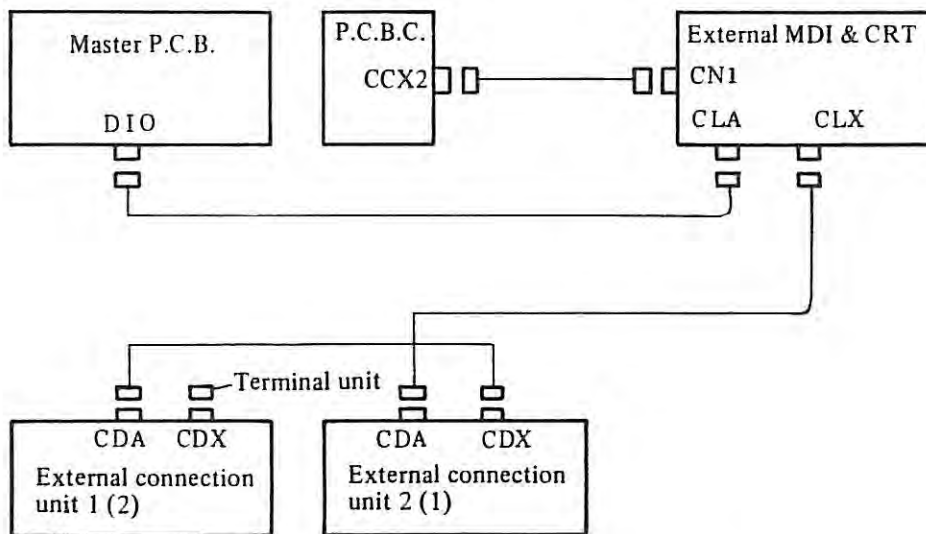

C01 MR-50RMA

(C111)

1	2	3	4	5	6	7	8	9	10	11	12	13	14	15	16	17	18	
		WN2	SKIP											OVC	AFL	PRC	*SVFZ	SPA
	19	20	21	22	23	24	25	26	27	28	29	30	31	32				
	OL		WNI6						HC	*SVFX	-C	MIX	SPC					
33	34	35	36	37	38	39	40	41	42	43	44	45	46	47	48	49	50	
+24N	WN4	WN1	WNB	COMW				+C	*SVFC	*-LC	*DECC	*+LC	*ITC	GST	SPB		SRN	

C02 MR-50RMA

(C112)

1	2	3	4	5	6	7	8	9	10	11	12	13	14	15	16	17	18
ST	*SP	*ESP	HS	J	MEM	DRN	RT	MLK	DLK	*OV8	*OV16	FIN	ERS		*DECX	*DECC	*DECT
	19	20	21	22	23	24	25	26	27	28	29	30	31	32			
	D	T		+T	+Z	+X	KEY		SBK	BDT1		SMZ	ABS	CDZ			
33	34	35	36	37	38	39	40	41	42	43	44	45	46	47	48	49	50
+24N	HX	HZ		-T	-Z	-X	EDT	ZRN	*OV1	*OV2	*OV4	*+LX	*-LX	*+LZ	*-LZ	*ELF	*EC LF

C03 MR-50RMA

(C113)

1	2	3	4	5	6	7	8	9	10	11	12	13	14	15	16	17	18	
GR1	GR2	GR3	.				MP1	MP2	RRW	MP4			*SSTP	SOR	UCL	OUCL	CLMP	OCL
	19	20	21	22	23	24	25	26	27	28	29	30	31	32				
	GR4			XAE	S28	S24	S22	S21	S18	S14	S12	S11	SF	OS				
33	34	35	36	37	38	39	40	41	42	43	44	45	46	47	48	49	50	
+24N	*ITX	*ITZ	STLK	ZAE	SAR	ROV1	ROV2	T28	T24	T22	T21	T18	T14	T12	T11	TF	OT	

C04 MR-50RMA

(C114)

1	2	3	4	5	6	7	8	9	10	11	12	13	14	15	16	17	18
SPL	OL	OL	OL	ZPC	OZ	OZP2			ZP2Z	ZP2X		RWD1	RWD2				OP2
	19	20	21	22	23	24	25	26	27	28	29	30	31	32			
	AL2	ZPZ	M11	M12	M14	M18	OM	DEN1	M01	MB	RST2	SB	DST2	OP1			
33	34	35	36	37	38	39	40	41	42	43	44	45	46	47	48	49	50
STL	AL1	ZPX	ZPT	M21	M22	M24	M28	MF	DEN2	MA	RST1	SA	DST1	OMR	M00	M02	M30

C05 MR-20RMA

(C110)

1	2	3	4	5	6	7
OR	OR					
	8	9	10	11	12	13
	R01	R02	R03	R04	R05	R06
14	15	16	17	18	19	20
R07	R08	R09	R10	R11	R12	OG

C09 MR-50RMA

(C119)

1	2	3	4	5	6	7	8	9	10	11	12	13	14	15	16	17	18
	UI13	UI9	UI14														
	19	20	21	22	23	24	25	26	27	28	29	30	31	32			
	OL	UI15	UI12						UI7	UI13							
33	34	35	36	37	38	39	40	41	42	43	44	45	46	47	48	49	50
+24N	UI10	UI8	UI11	COMU				UI2	UI6	UI1	UI5	UI0	UI4				

C10 MR-50RMA

(C120)

1	2	3	4	5	6	7	8	9	10	11	12	13	14	15	16	17	18
	BDT9	BDT8	ED9	ED10	ED13												BDT6
	19	20	21	22	23	24	25	26	27	28	29	30	31	32			
	ED11	ED12	ED8	BDT4			ED15										
33	34	35	36	37	38	39	40	41	42	43	44	45	46	47	48	49	50
+24N		EDT7			BDT5		ED14							BDT2	BDT3		

C11 MR-50RMA (with external tool compensation A)

(C121)

1	2	3	4	5	6	7	8	9	10	11	12	13	14	15	16	17	18	
OF31	OF32	OF34	OF11	OF12	OF14	OF22	OF24						DERR	DEND	XSTB1	XSTB2	REND1	REND2
	19	20	21	22	23	24	25	26	27	28	29	30	31	32				
	OF38	OFSN	DIX	OF18									ZSTB1	ZSTB2				
33	34	35	36	37	38	39	40	41	42	43	44	45	46	47	48	49	50	
+24N				OF21														

C11 MR-50RMA (with external data input)

(C121)

1	2	3	4	5	6	7	8	9	10	11	12	13	14	15	16	17	18
EA0	EA1	EA2	ED0	ED1	ED2	ED5	ED6			ED7			ESTB	EA6			OER
	19	20	21	22	23	24	25	26	27	28	29	30	31	32			
	EA3	EA4	EA5	ED3													
33	34	35	36	37	38	39	40	41	42	43	44	45	46	47	48	49	50
+24N				ED4												ERE	OES

C12 MR-50RMA

(C122)

1	2	3	4	5	6	7	8	9	10	11	12	13	14	15	16	17	18
UO4	OL	OL	OL	UO3	OUA							UO10	OUF				OUC
	19	20	21	22	23	24	25	26	27	28	29	30	31	32			
	OUU	OU1						UO11		OUI	OUE	OUB	UO7				
33	34	35	36	37	38	39	40	41	42	43	44	45	46	47	48	49	50
UO5	UO8	UO0	UO2						OUG	UO15	UO9	UO6	OUH	UO12	UO13	UO14	

Connection Unit 1

Connection Unit 2

C06 MR-20RMAD
(C109)

1	2	3	4	5	6	7
OV	OV	*RSX	*RSZ			
X	8	9	10	11	12	13
		DD1	DD2	DD4	DD8	DWT
14	15	16	17	18	19	20
	+5V	+5V	+5V	+5V	+5V	

DIO MR-20RFD
(C104)

1	2	3	4	5	6	7
SDO	*SDO	STB	*STB	STA	*STA	OV
X	8	9	10	11	12	13
					OV	OV
14	15	16	17	18	19	20
MSRDY	*MS RDY	SL RDY	*SL RDY	SDI	*SDI	

C14 MR-20RMH

1	2	3	4	5	6	7
PR	TE	ERR	TTY3	+6V	TTY2	TTY1
X	8	9	10	11	12	13
	OG	SD	OV	CH1	CH2	CH3
14	15	16	17	18	19	20
CH4	CH5	CH6	CH7	CH8	CH9	PI

C15 DBM-25S

(Lock DZ0418-J2 made by Japan Aviation Electronic Industry Ltd.)

1	2	3	4	5	6	7	8	9	10	11	12	13
FG	SD	RD	RS	CS	DR	SG	CD					
X	14	15	16	17	18	19	20	21	22	23	24	25
							ER					+24V

(Note) When input and output interface option is equipped, both connector C14 and connector C15 are incorporated on the front cabinet.

C16 MR-50RMD

1	2	3	4	5	6	7	8	9	10	11	12	13	14	15	16	17	18
	P1	OV	P2	OV	P3	OV	P4	OV	P5	OV	P6	OV	P7	OV	P8	OV	
X	19	20	21	22	23	24	25	26	27	28	29	30	31	32			
	PS	OV		*TER	OV		RDT	OV		*RWT	OV	FDT	OV				
33	34	35	36	37	38	39	40	41	42	43	44	45	46	47	48	49	50
	OPT	OV		*RWD	OV	*CLT	OV	*REEL	OV	OV	OV	OV	OV	OV	OV	OV	

C07 MR-20RMD
(C108)

1	2	3	4	5	6	7
OH	OH	OH	+5H	+5H	+5H	
X	8	9	10	11	12	13
	HA	HB	ZDX	ZDZ	ZDT	
14	15	16	17	18	19	20
(SC)	(*SC)	(PA)	(*PA)	(PB)	(*PB)	OG

Z/P MR-20RMD
(C107)

1	2	3	4	5	6	7
OH	OH	OH	+5H	+5H	+5H	
X	8	9	10	11	12	13
14	15	16	17	18	19	20
SC	*SC	PA	*PA	PB	*PB	OG

Note: When T or C axis is equipped with, the connector for position coder is C19.

C19 MR-20RMD

1	2	3	4	5	6	7
OH	OH	OH	+5H	+5H	+5H	
X	8	9	10	11	12	13
14	15	16	17	18	19	20
SC	*SC	PA	*PA	PB	*PB	OG

(Note) No shield terminal is provided with connection C19. The cable shield must be clamped by the cable clamp metal fixture.

C08 MR-20RMA
(C110)

1	2	3	4	5	6	7
	ENB1					VCMS
X	8	9	10	11	12	13
14	15	16	17	18	19	20
	ENB2				ECS	OG

Note: When T or C axis is equipped with, the connector for S analog output is C18.

C18 MR-20RMA

1	2	3	4	5	6	7
	ENB1			ZDC		VCMS
X	8	9	10	11	12	13
14	15	16	17	18	19	20
	ENB2				ECS	

(Note) No shield terminal is provided with connector C18. The cable shield must be clamped by the cable clamp metal fixture.

2. Connection Diagram

- Notes: 1. The rating of the signal output through contacts is DC24V, 200 mA (load resistor). When a lamp is used, a resistor to display dim lamp must be connected as in the figure above. The capacity of the lamp should be DC 24V 1W (40 mA) or less and the resistance should be 2.2 k Ω and 1/2W or more.
2. ON and OFF of error detect and chanfering signals are preferred to be done by the miscellaneous function rather than the manual switch.
3. +24V must not be grounded on the machine side. The contacts connected to the NC must be separated from the grounding.
4. Connector names in the following diagrams are for free standing type, built-in type 1 and unbundled type cabinets.

Connector names for built-in type 2 cabinet are different from those for the other cabinets as follows:

Connector names for free standing type, built-in type 1 and unbundled type cabinets	Connector names for built-in type 2 cabinet
C01	C111
C02	C112
C03	C113
C04	C114
C05	C110
C06	C109
C07	C108
C08	C110
C09	C119
C10	C120
C11	C121
C12	C122
C14	C 14
C15	C 15
C16	C 16
DIO	C104
X	C105
Z	C106
Z/P	C107
CCX2	C101

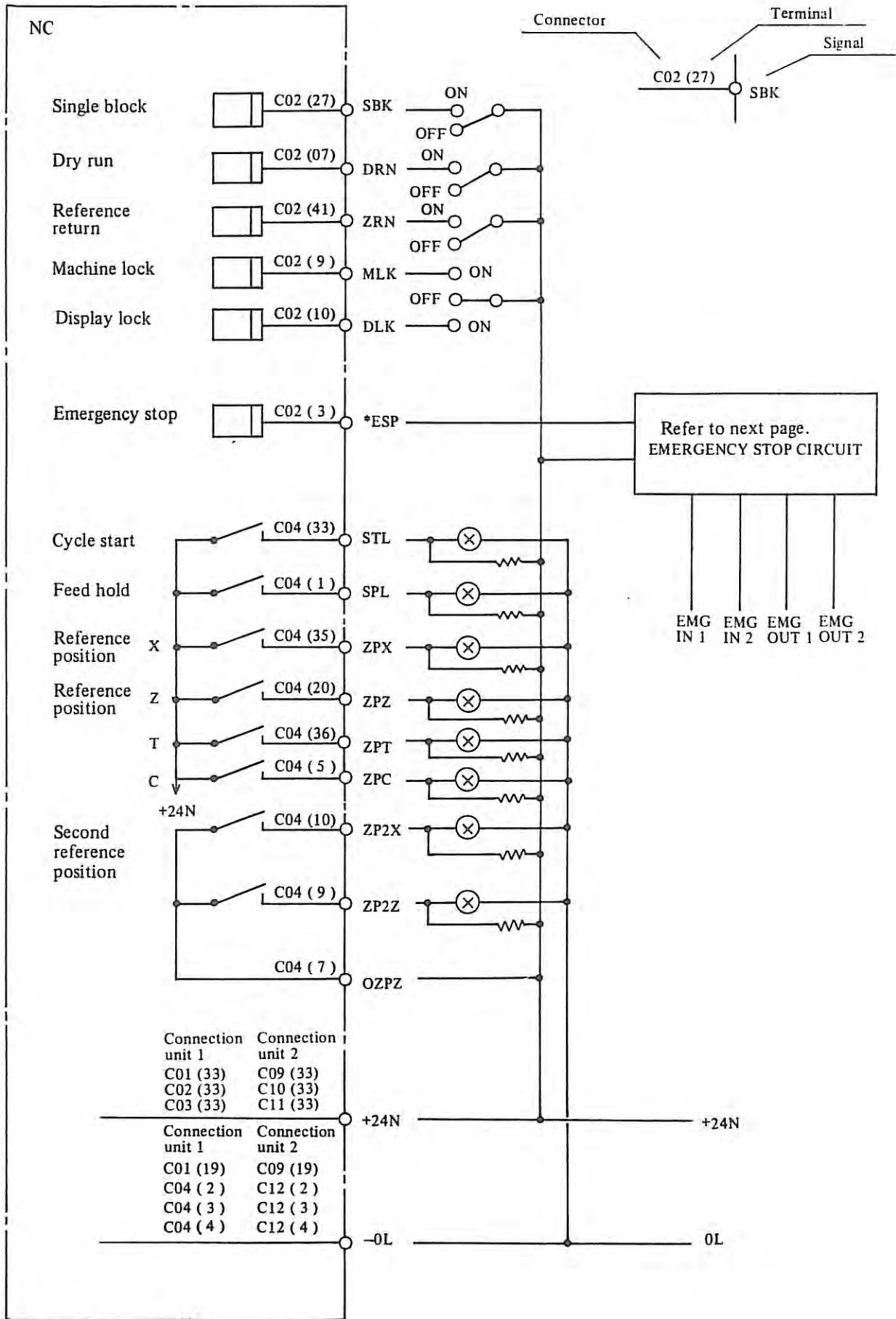

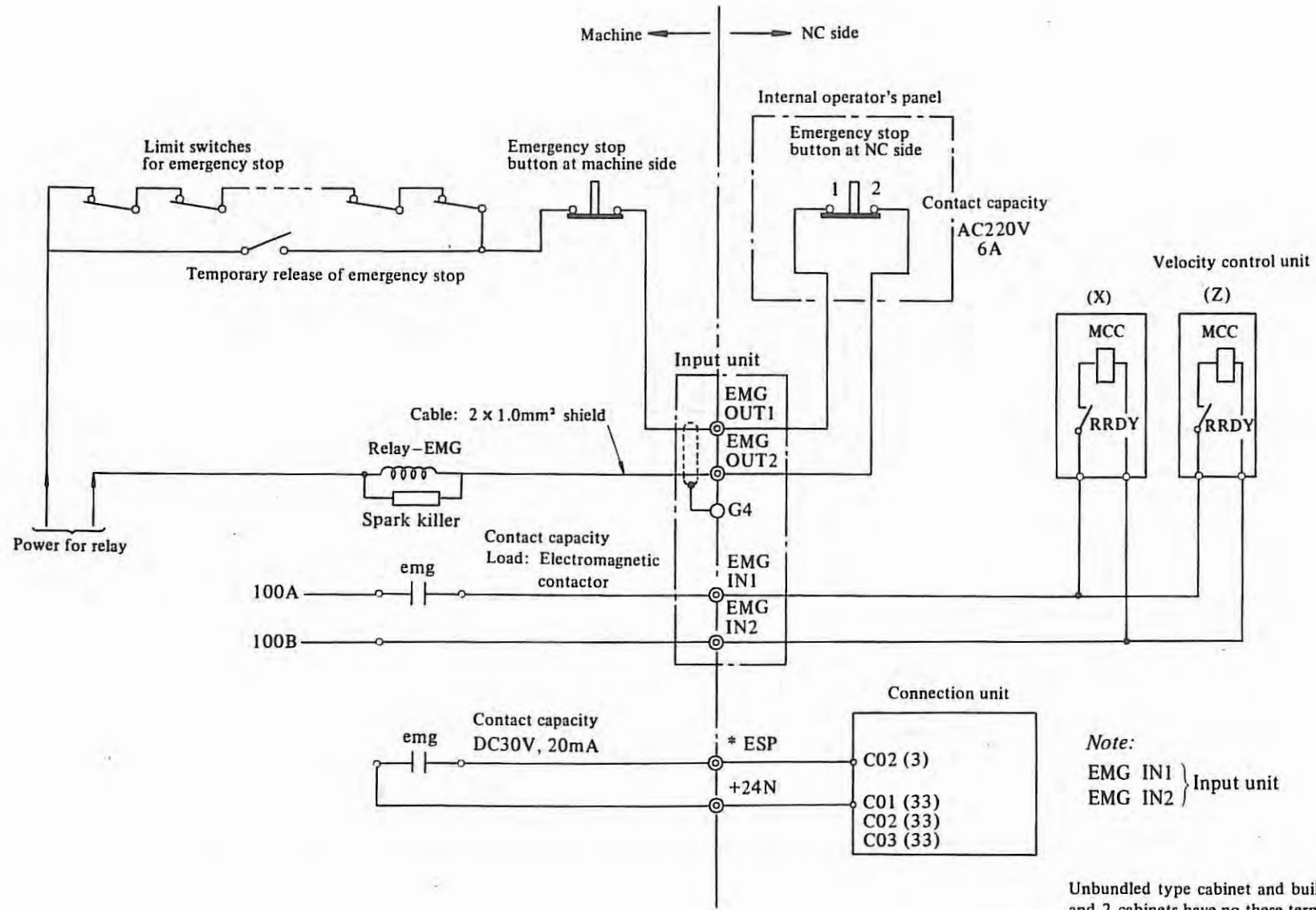

Note:
 EMG IN1 } Input unit
 EMG IN2 }

Unbundled type cabinet and built-in 1 and 2 cabinets have no these terminals. AC 100V of the servo unit should be cut off at the machine side.

Connection diagram of emergency stop signal

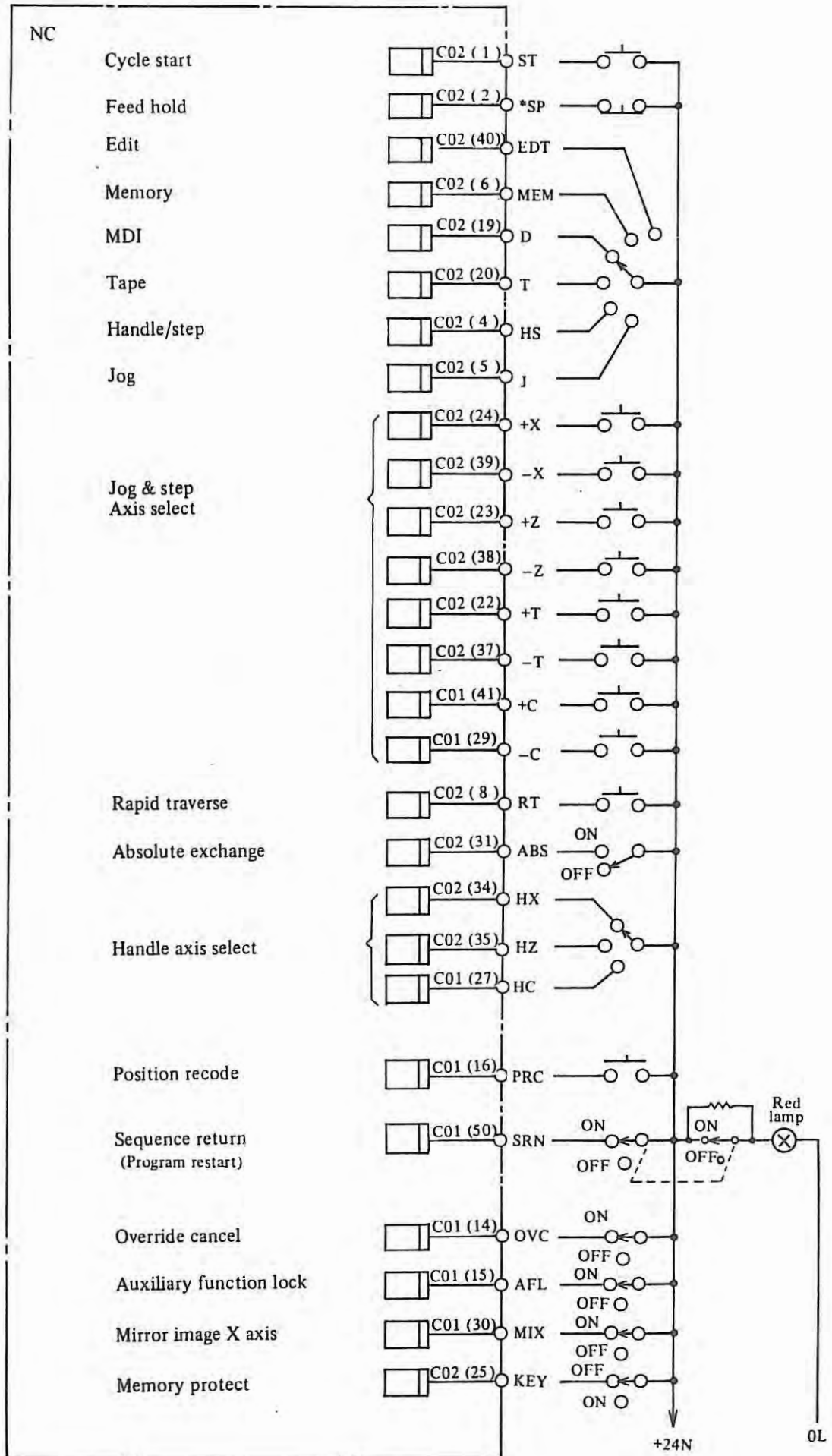

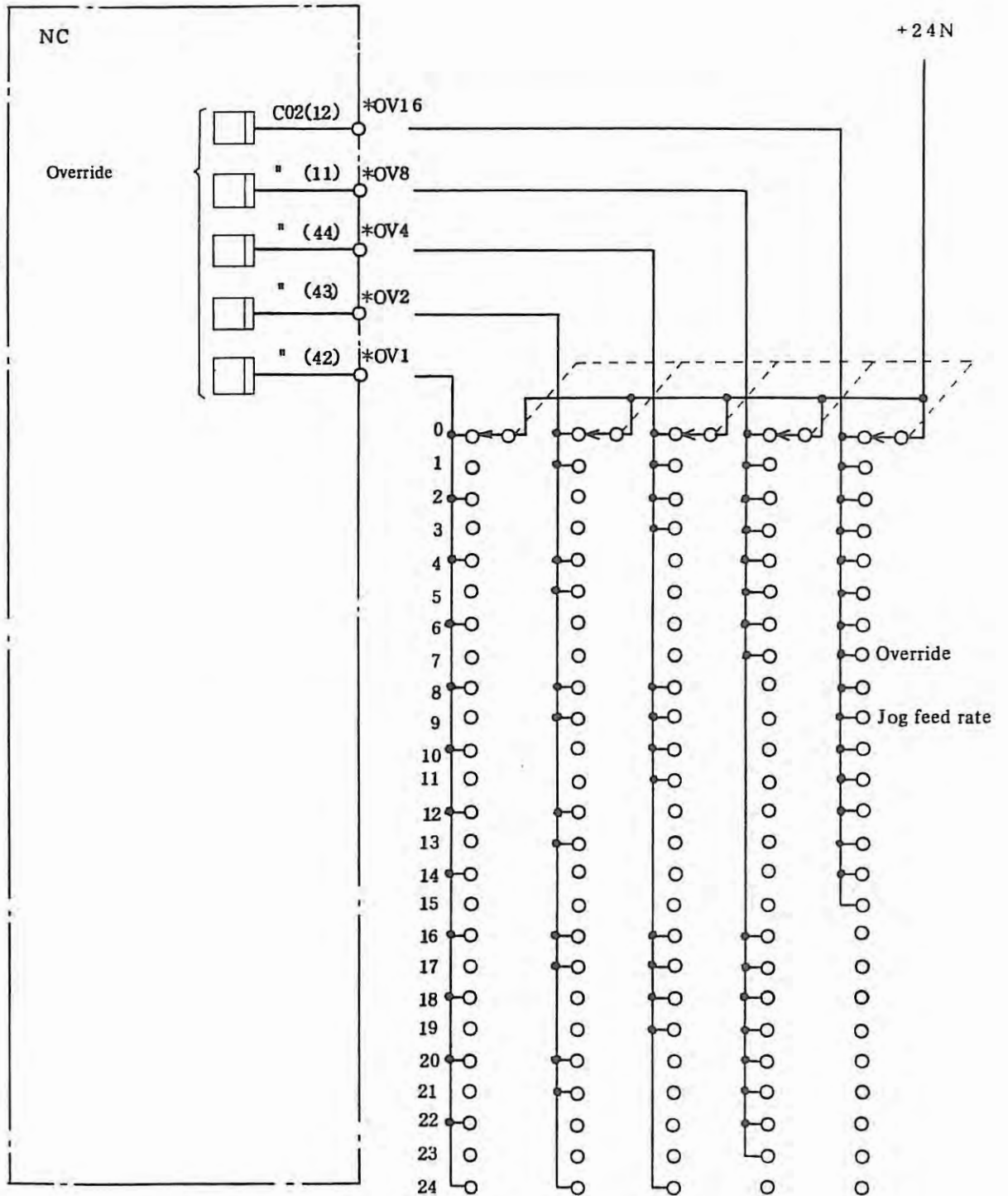

Note: The override signals are used for either feed rate override or jog feed rate.

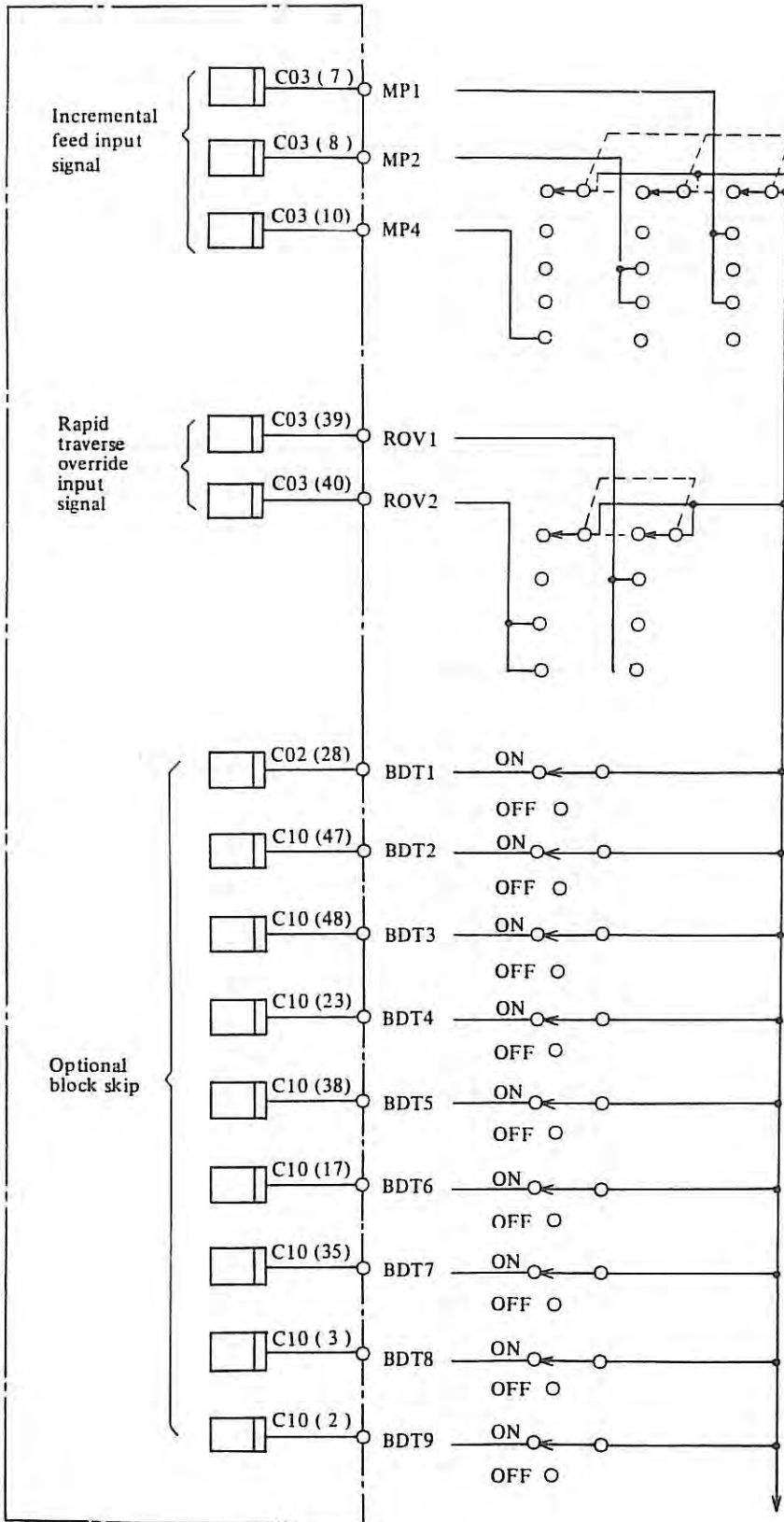

MP4	MP2	MP1	Step	MPG
0	0	0	1 μ m	1 μ m
0	0	1	10 μ m	10 μ m
0	1	0	100 μ m	100 μ m
0	1	1	1mm	100 μ m
1	0	0	10mm	1 μ m
1	0	1	100mm	10 μ m
1	1	0	100mm	100 μ m
1	1	1	100mm	100 μ m

MPG: Manual pulse generator

ROV2	ROV1	Feed rate
0	0	100%
0	1	50%
1	0	25%
1	1	F ₀

0: Contact open
1: Contact close

BDT1 is the same as conventional BDT.

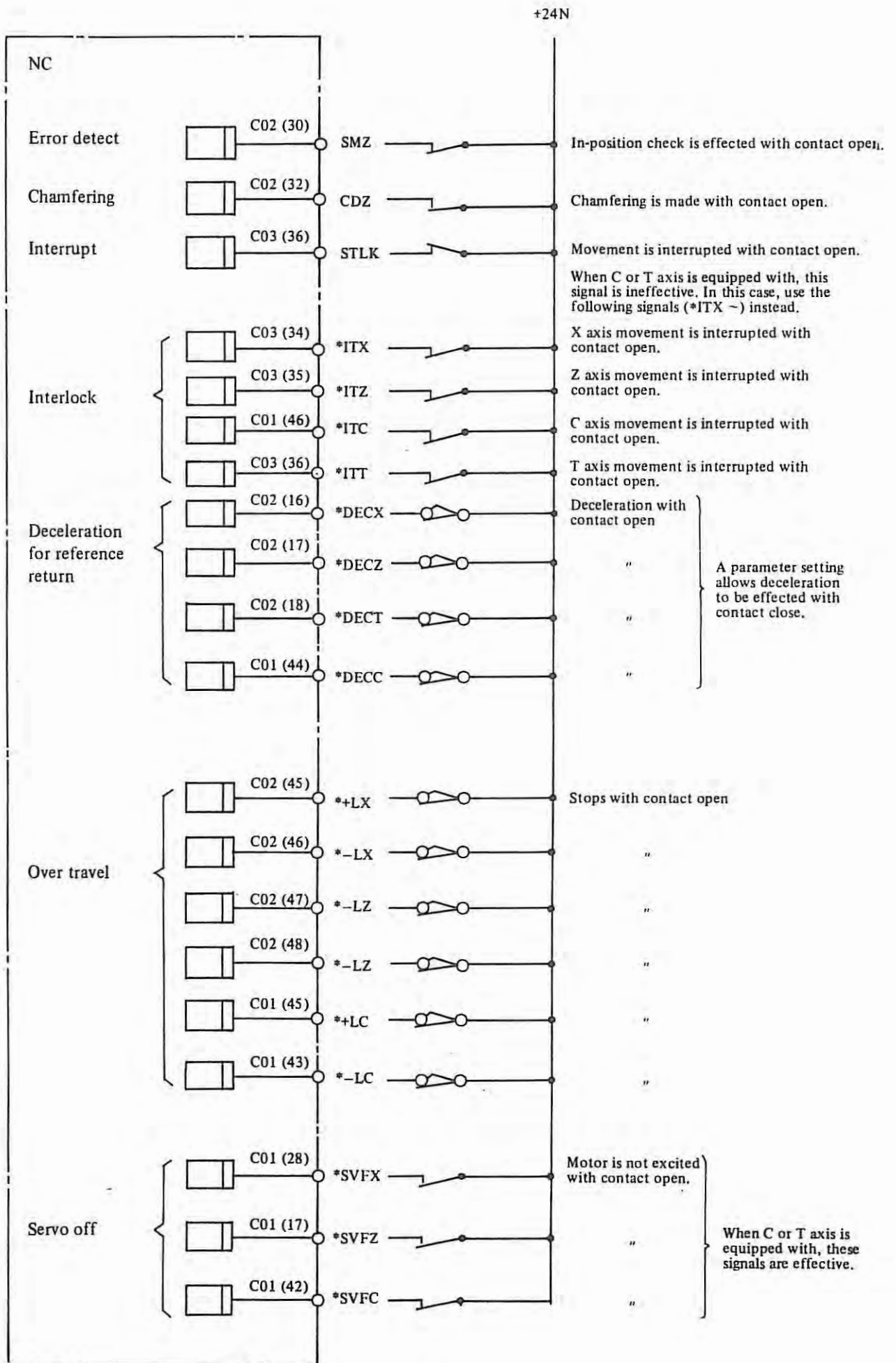

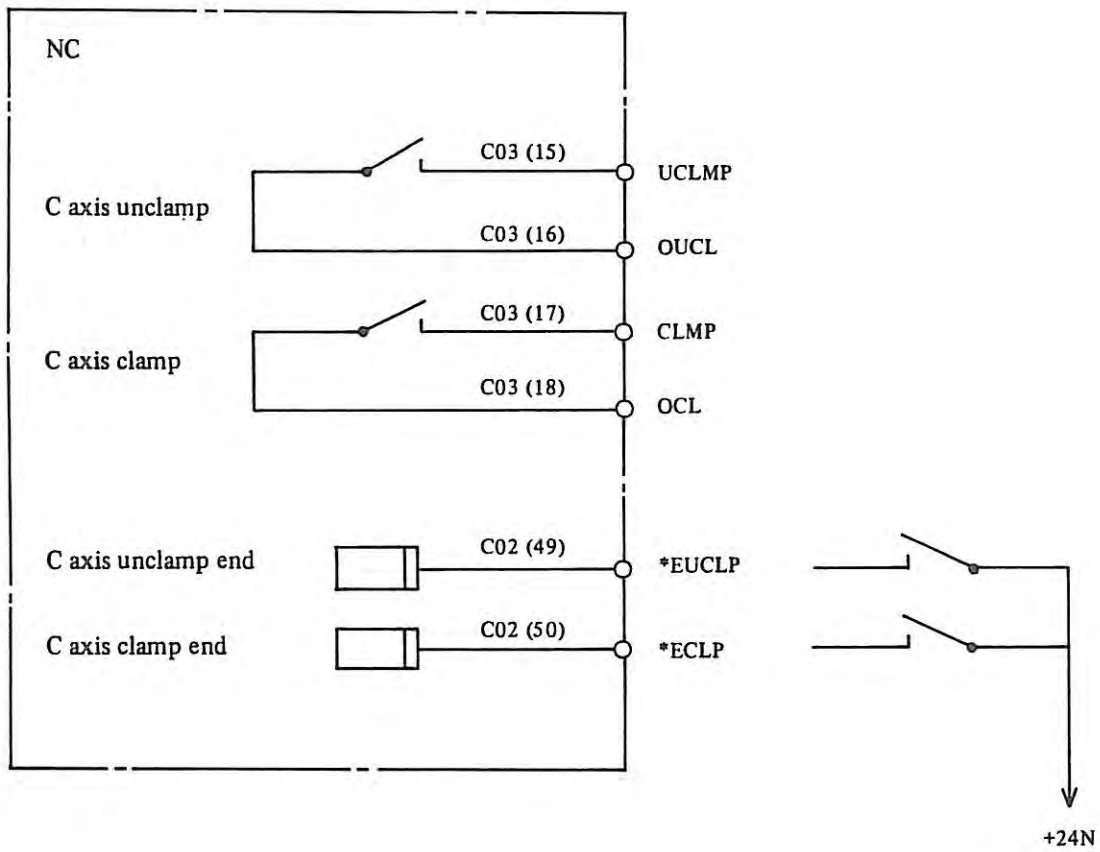

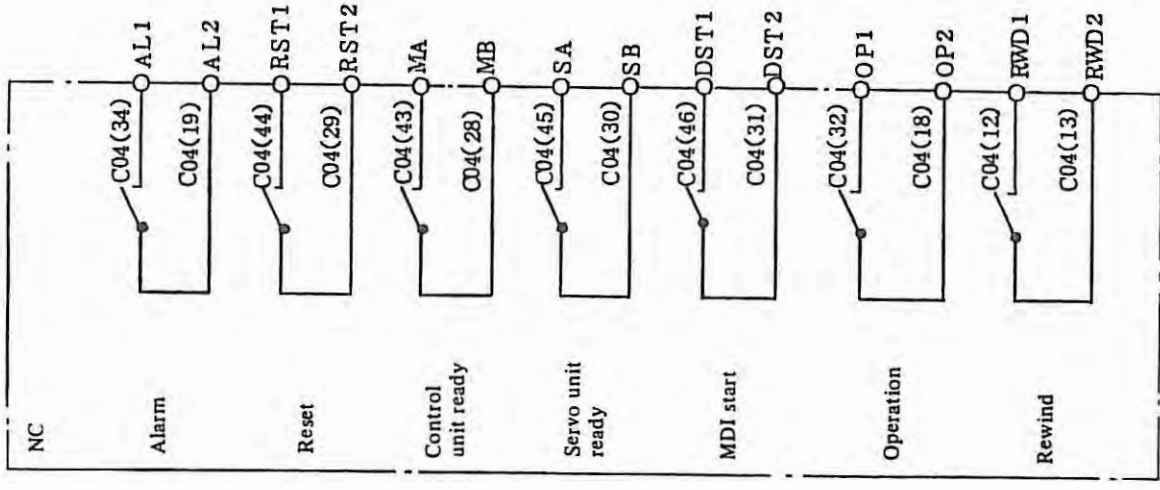
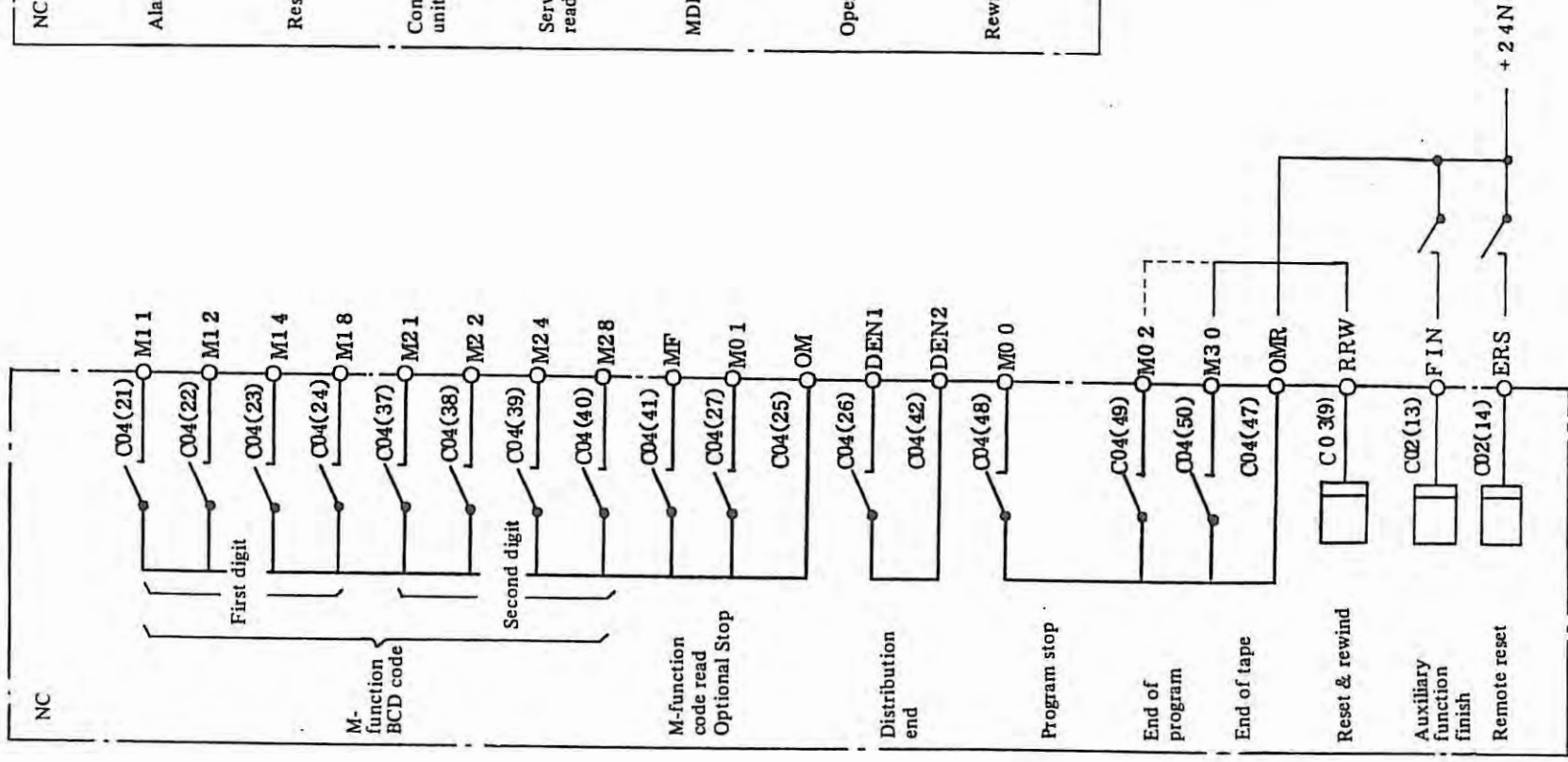

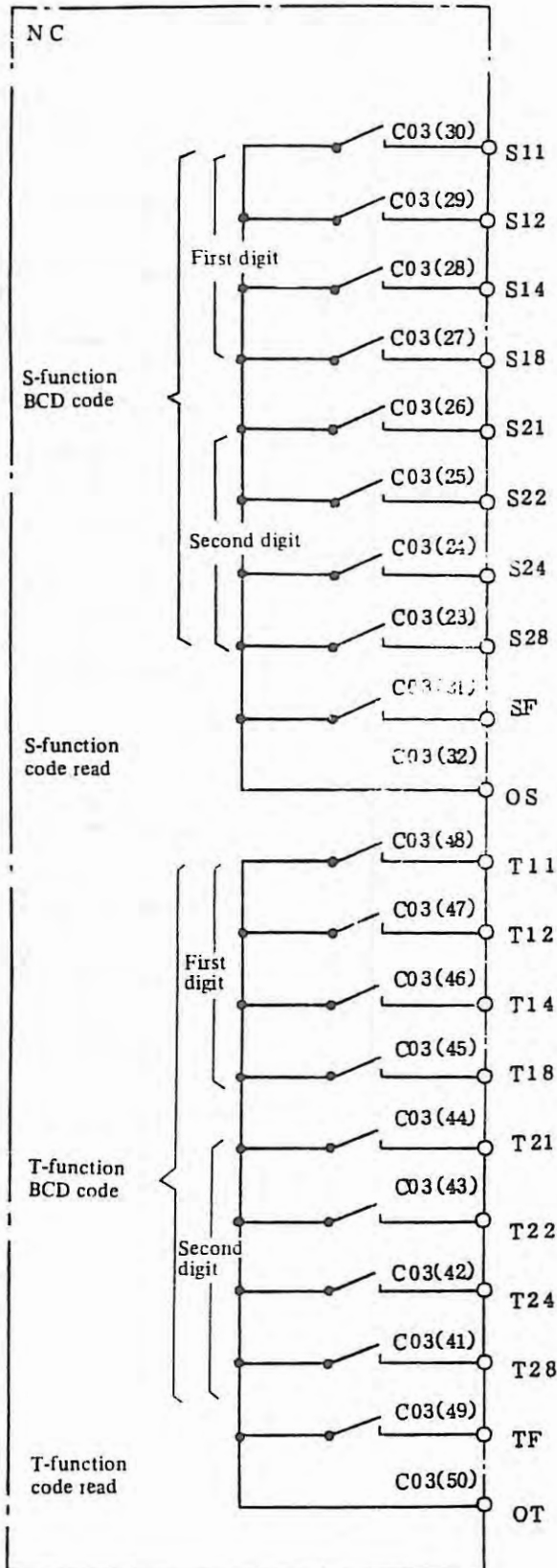

T2-digit T □□
 T4-digit T □□□□

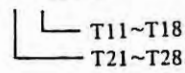

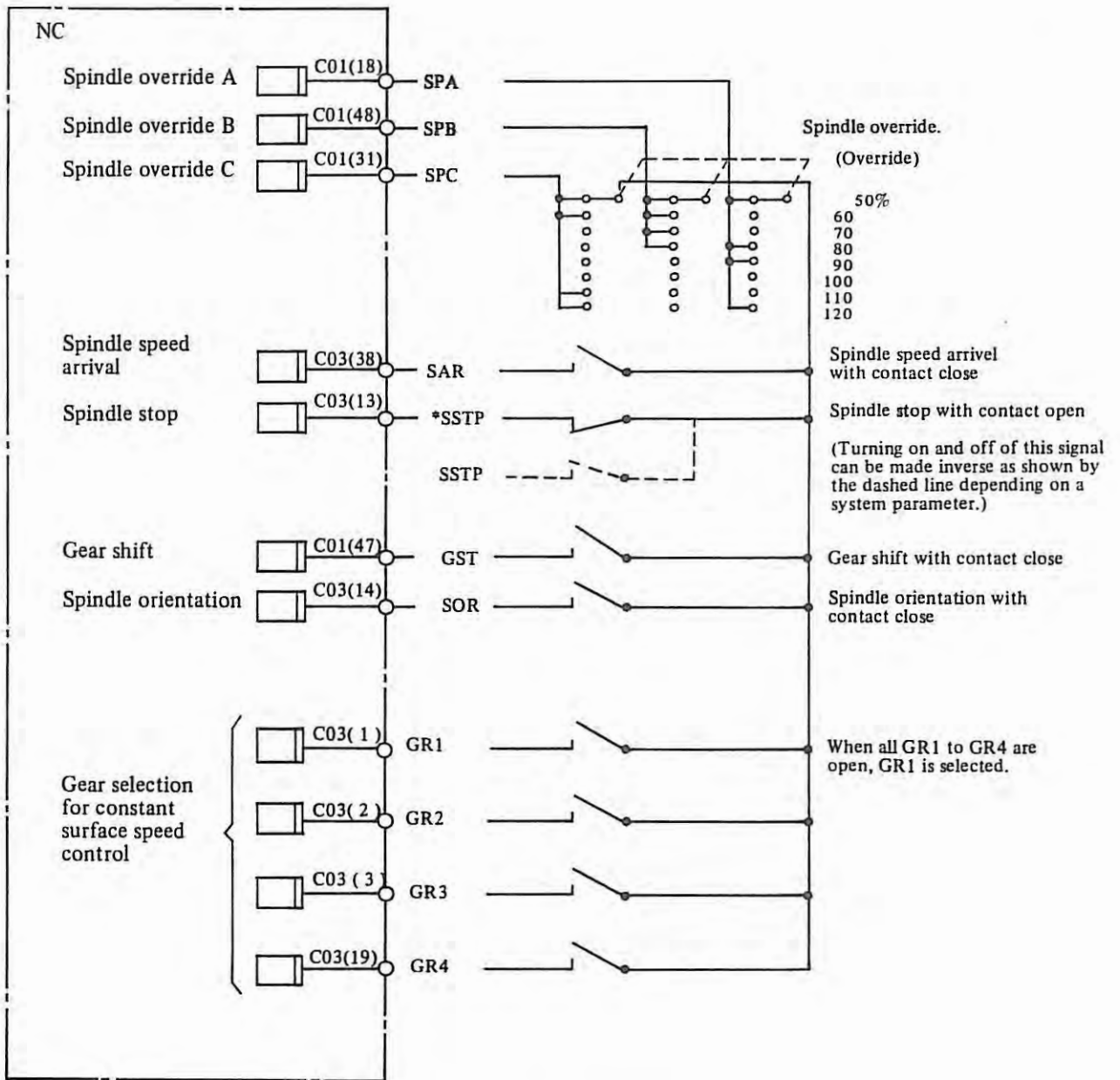

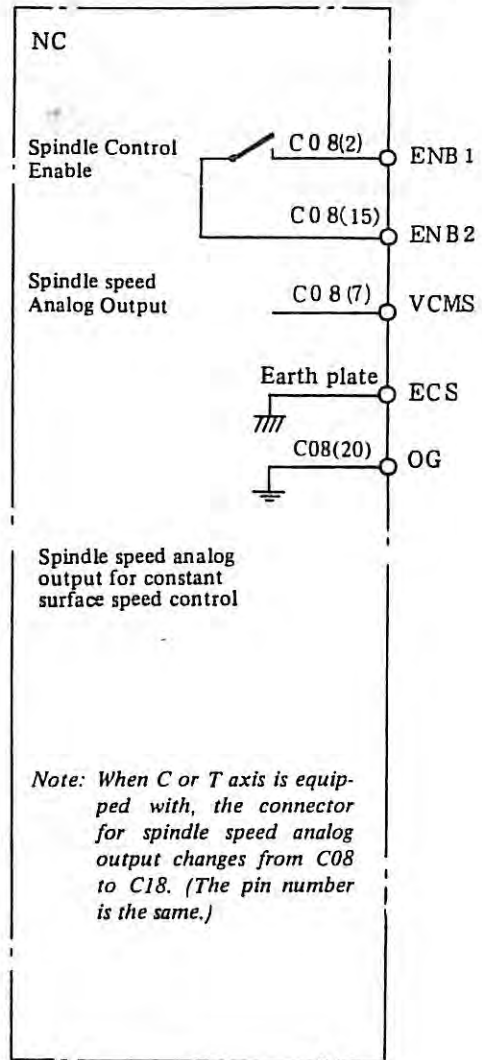
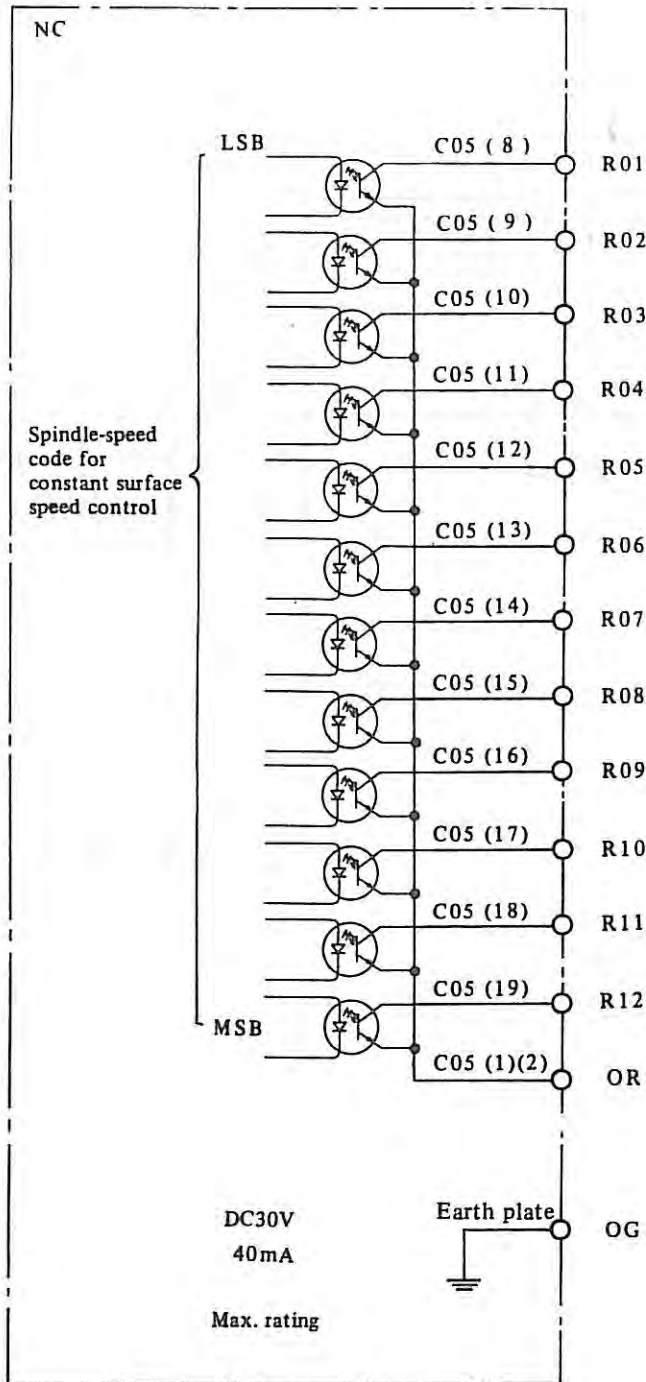

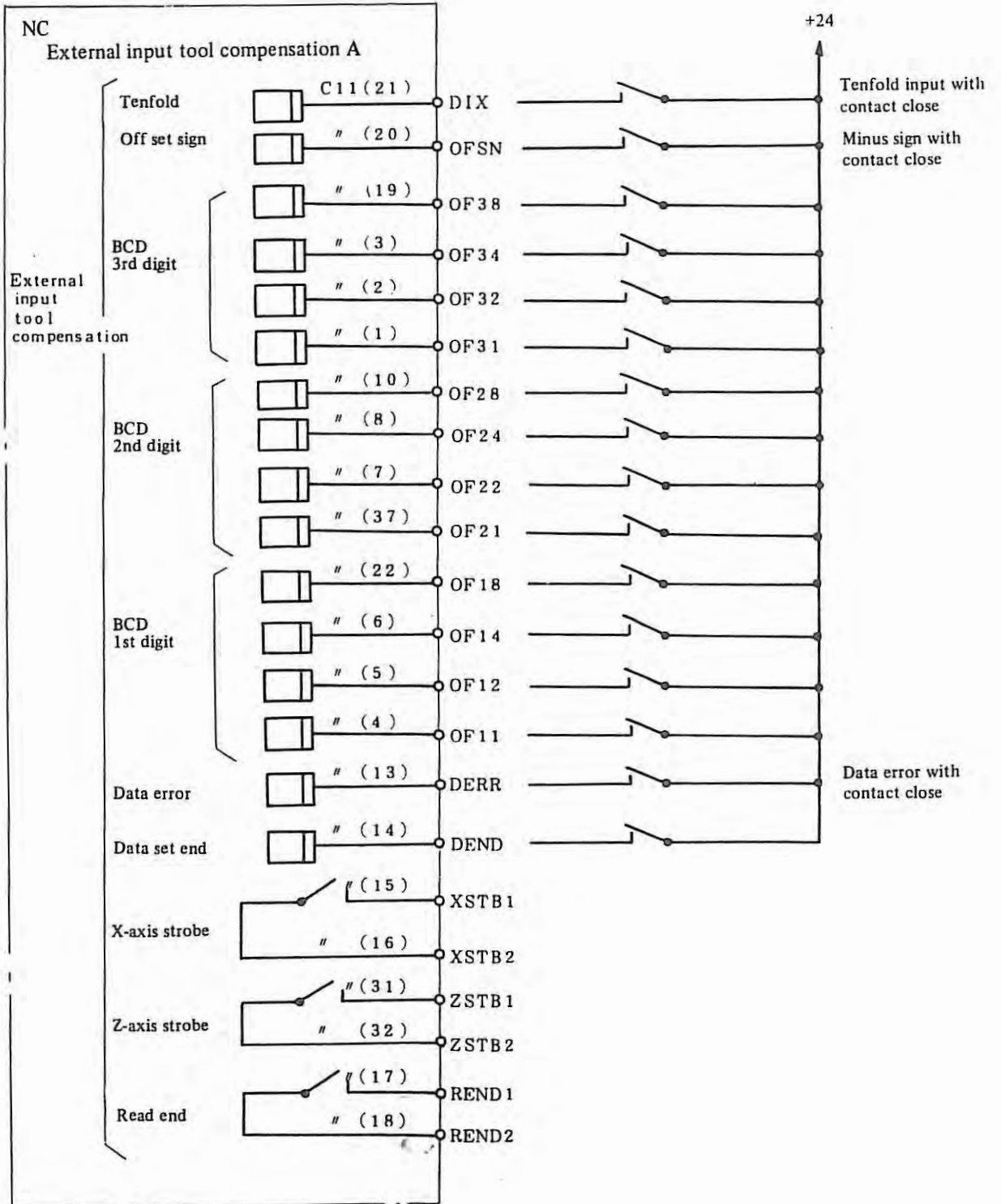

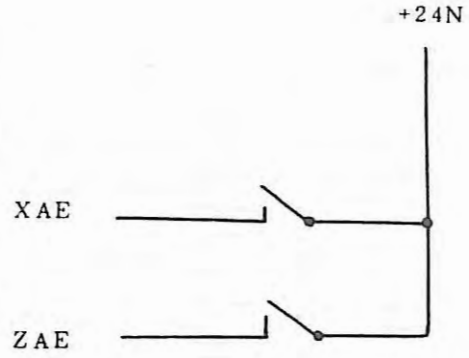
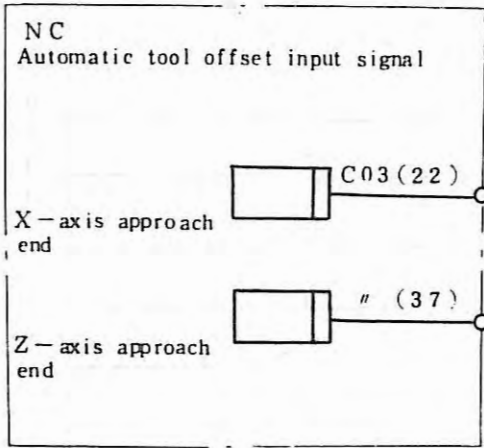

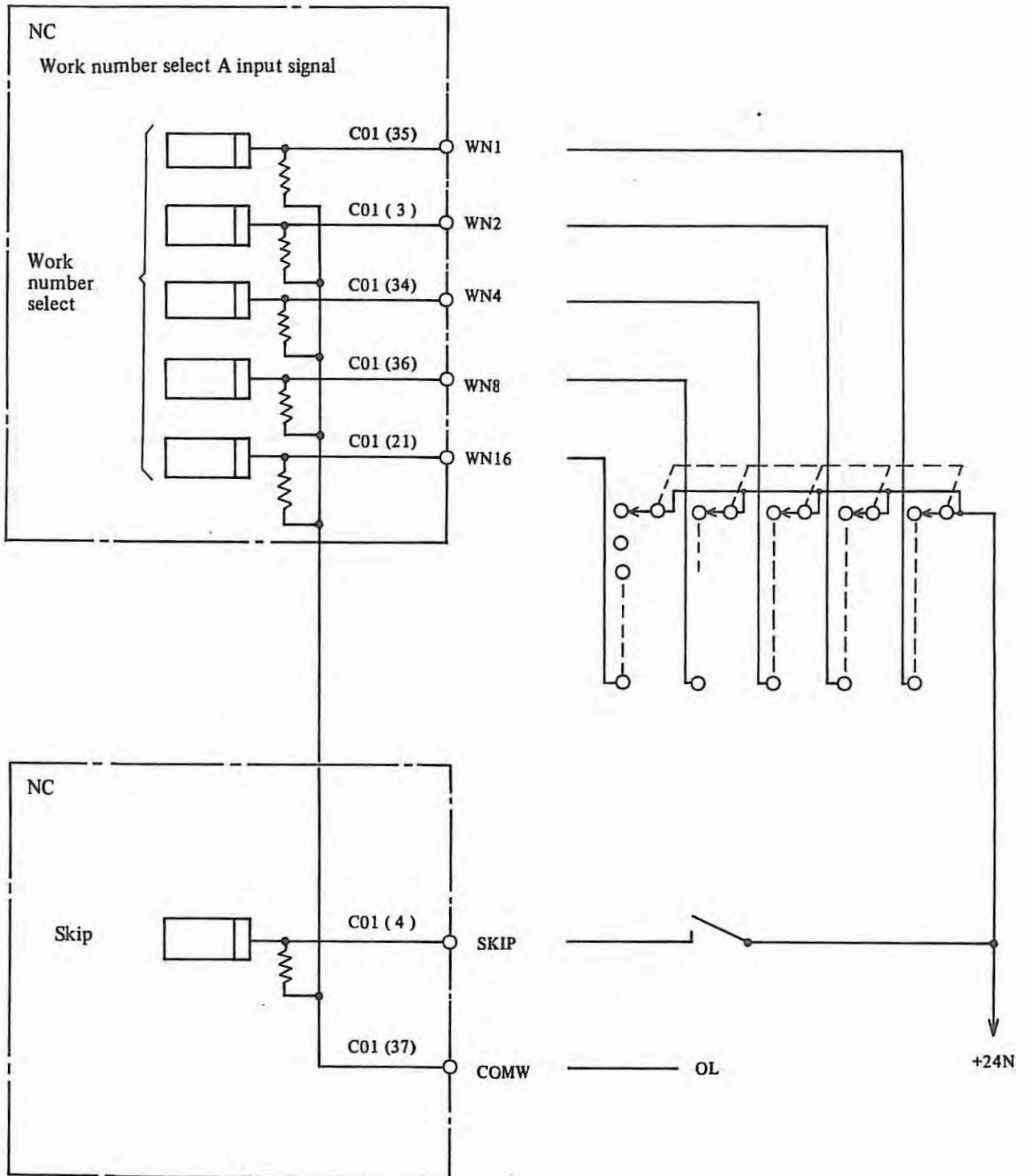

Note: When signals WN1 ~ 16 or SKIP is used, a line must be connected between C01 (37) and OL.

External Data Input

The followings are included:

- External work number select C
- External input tool compensation C
- External alarm message
- External operator message

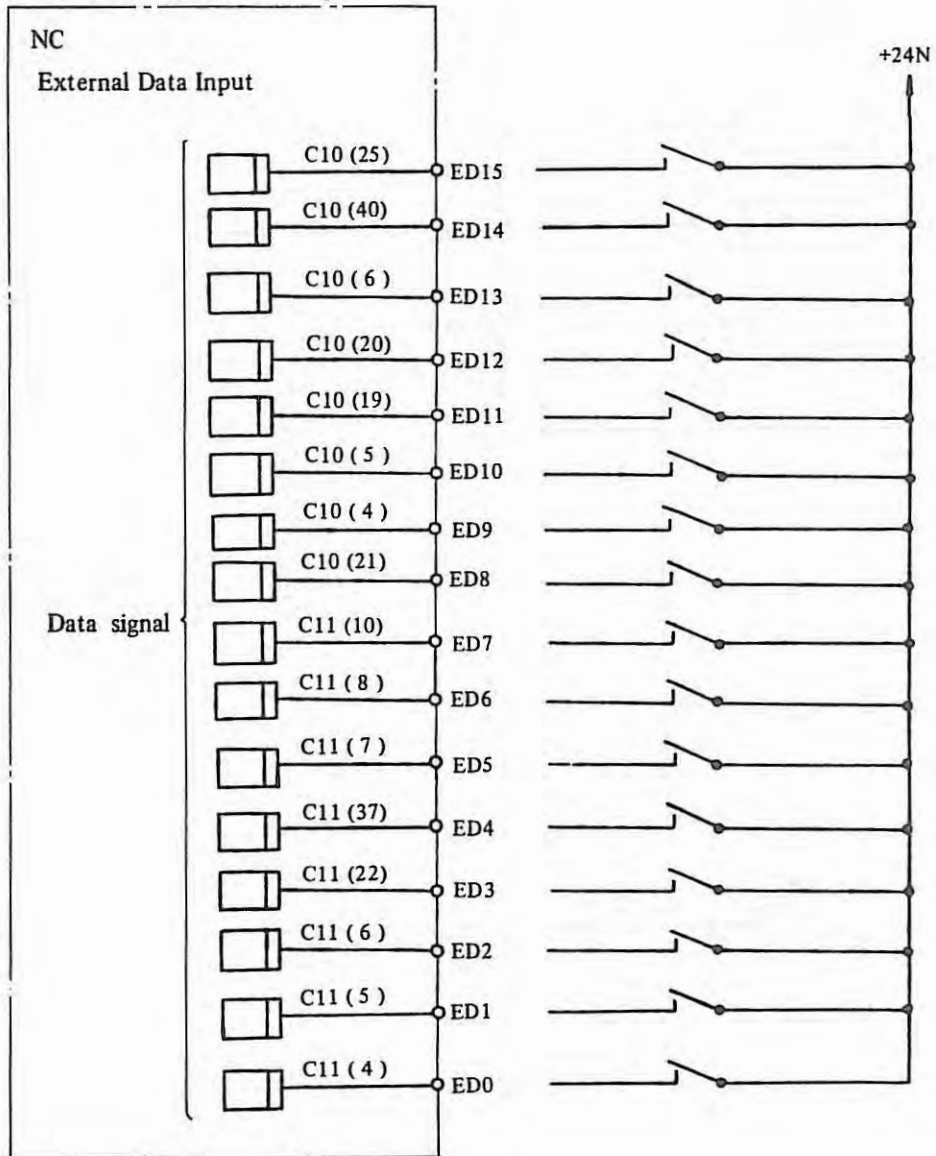

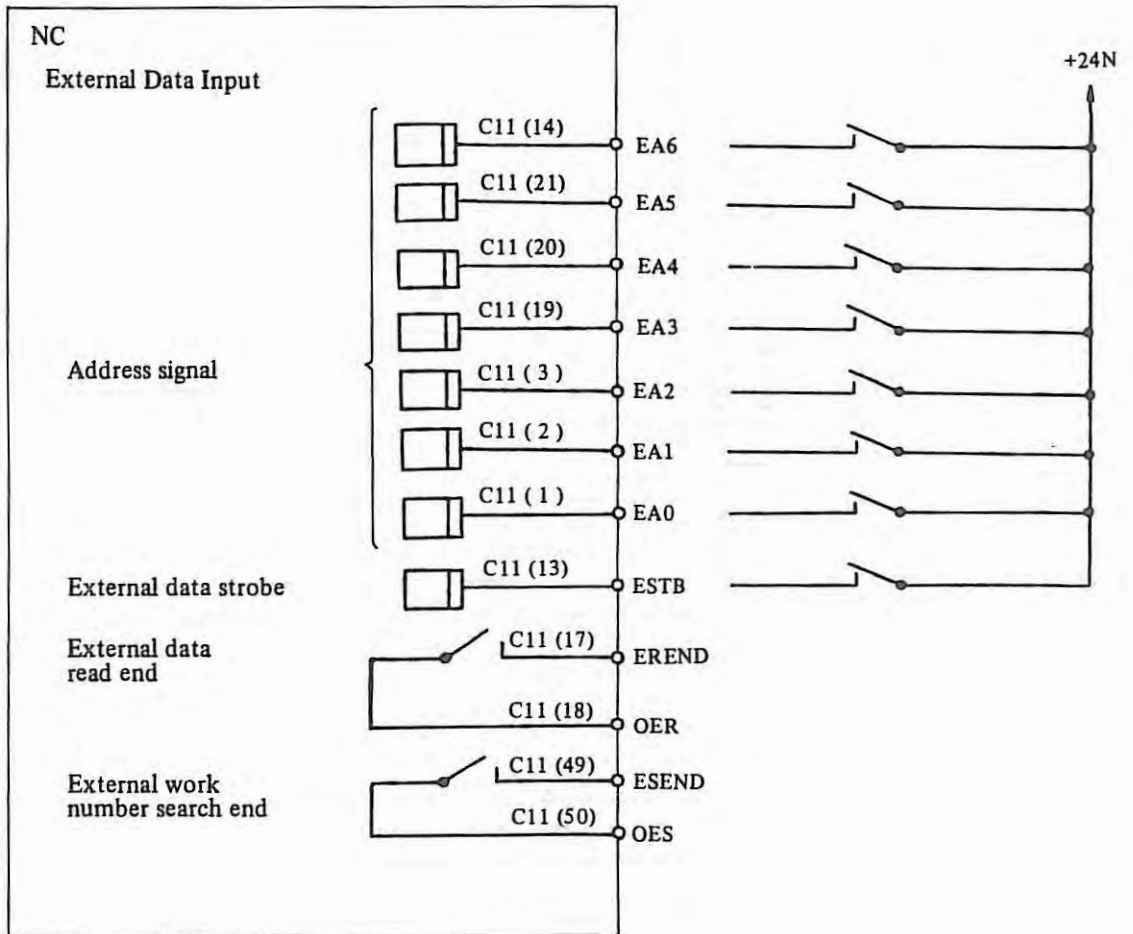

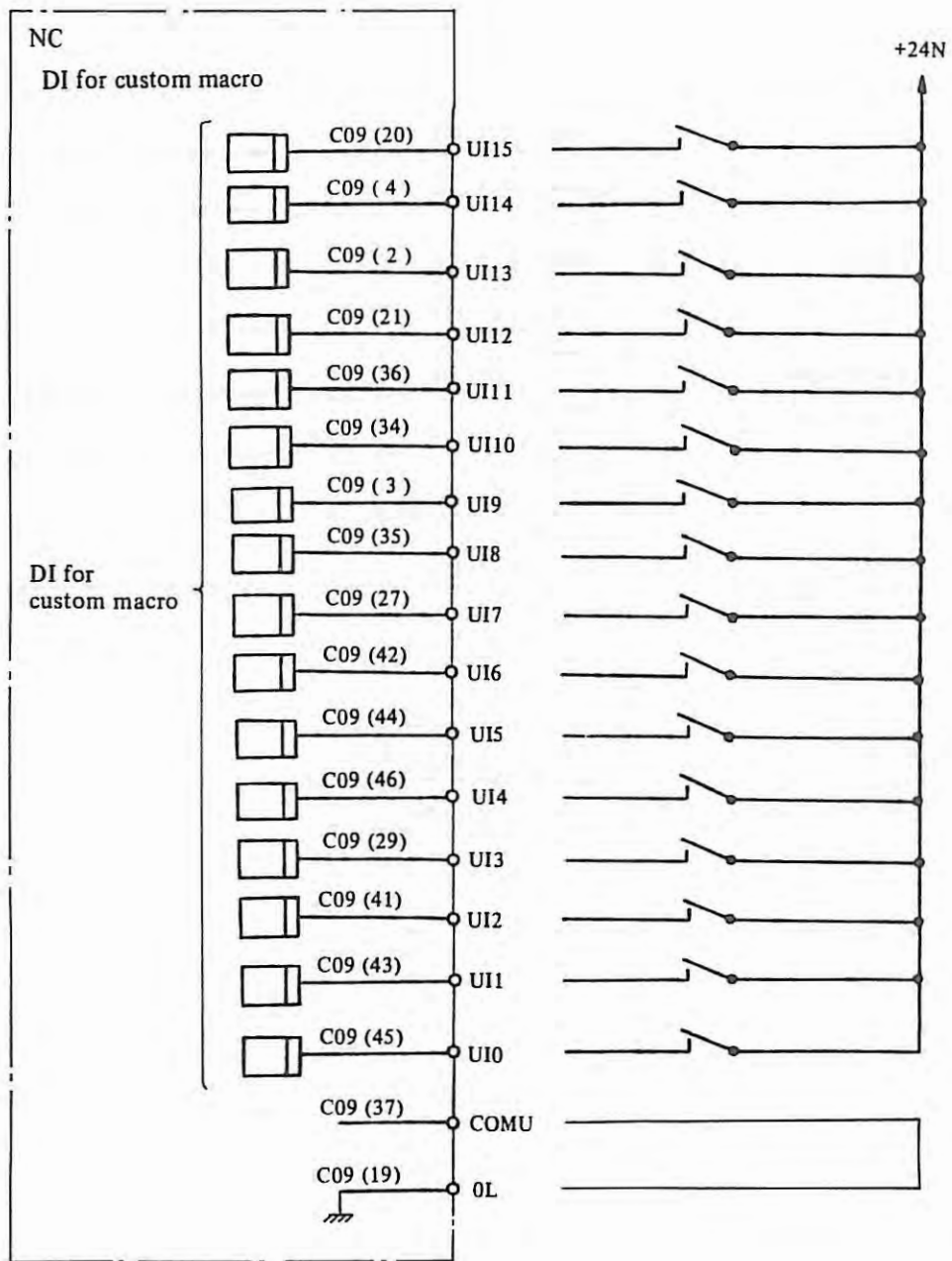

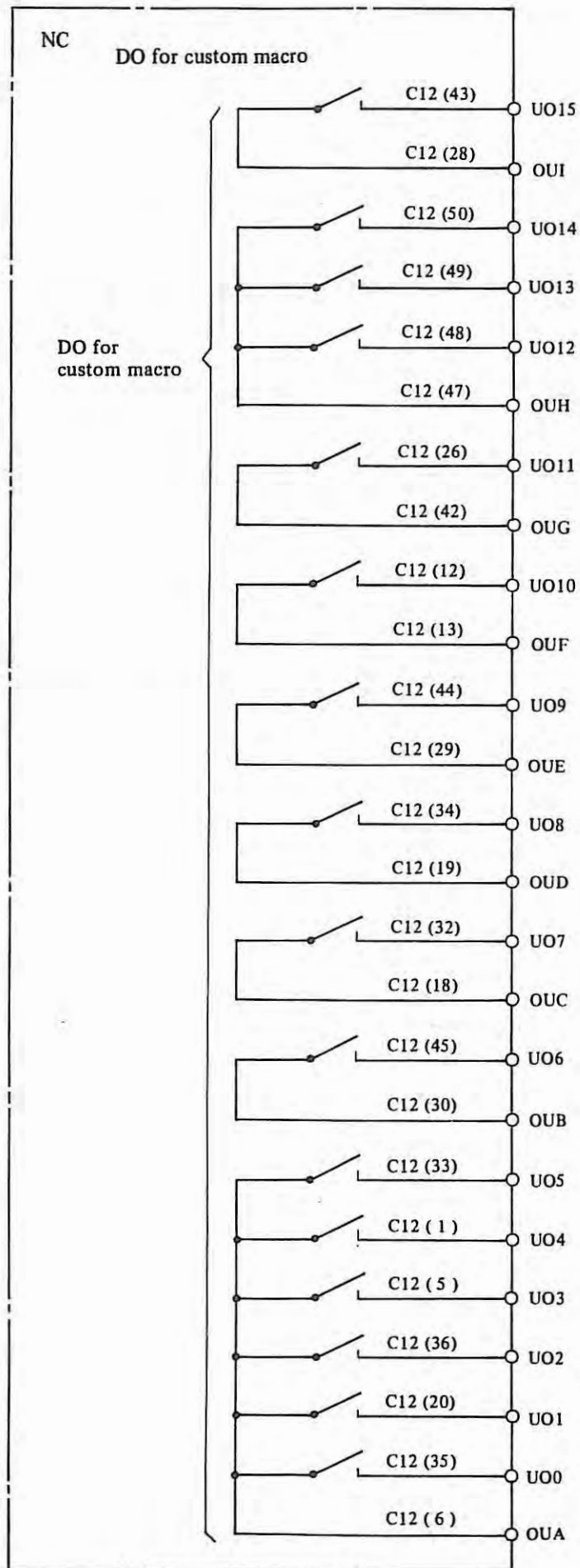

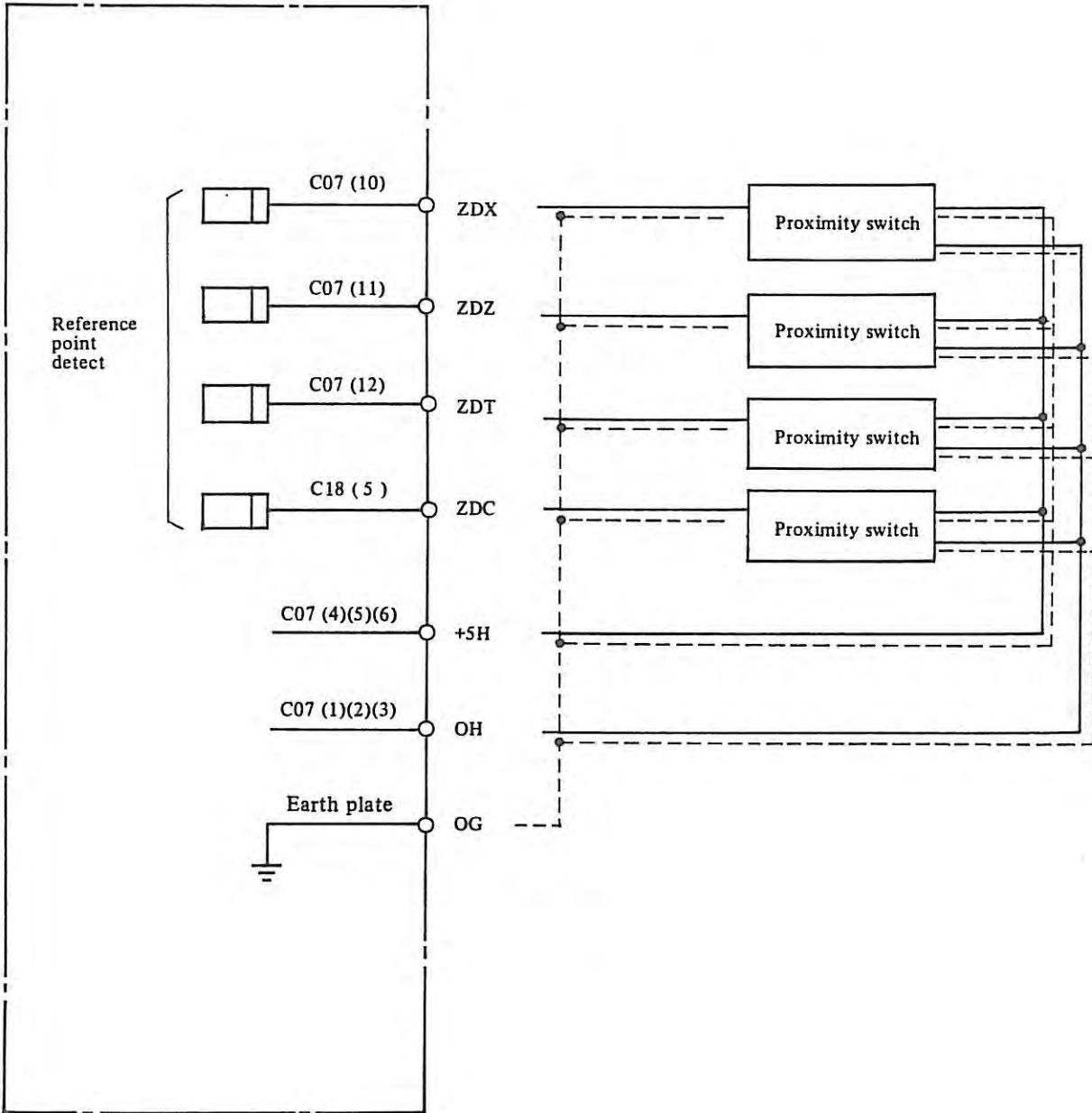

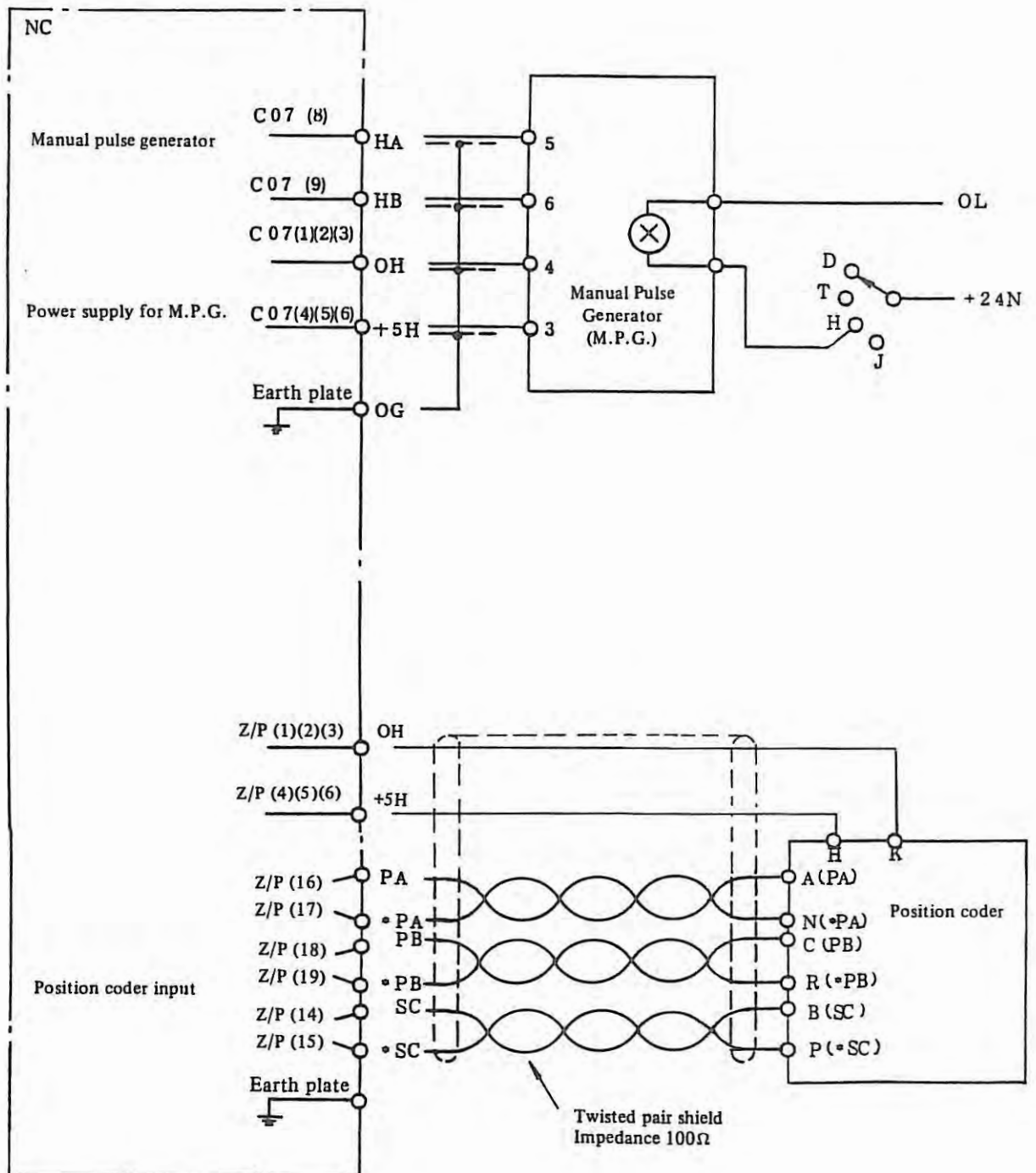

Notes: 1. Consumed current by the position coder is 0.35A. It is your responsibility to select the number of lines for signals OH and +5H. The voltage drop between NC and position coder should be less than 0.2V in both ways. (Refer to section 6.2.58 for details.)

2. When T or C axis is equipped with, the connector for position coder is C19.

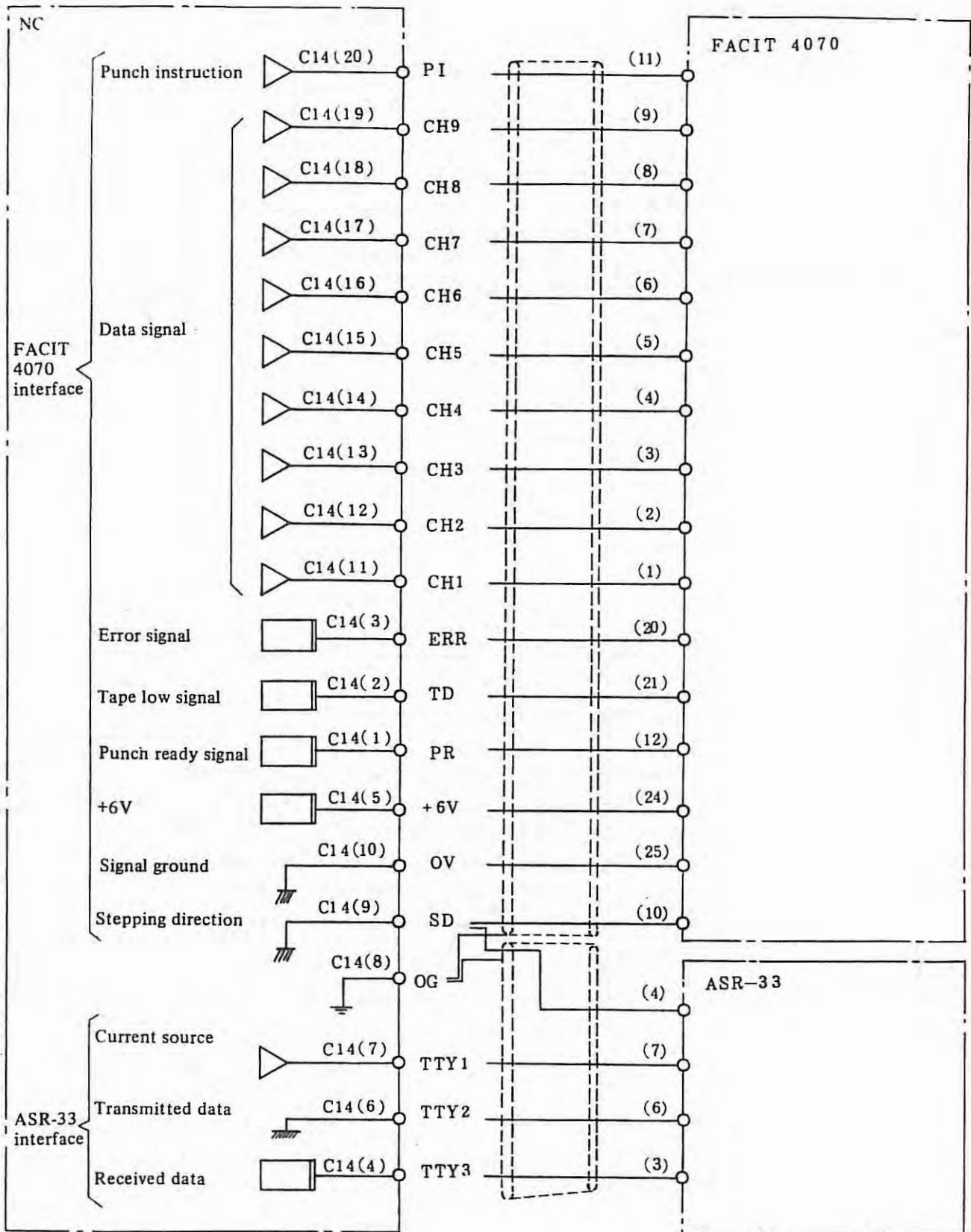

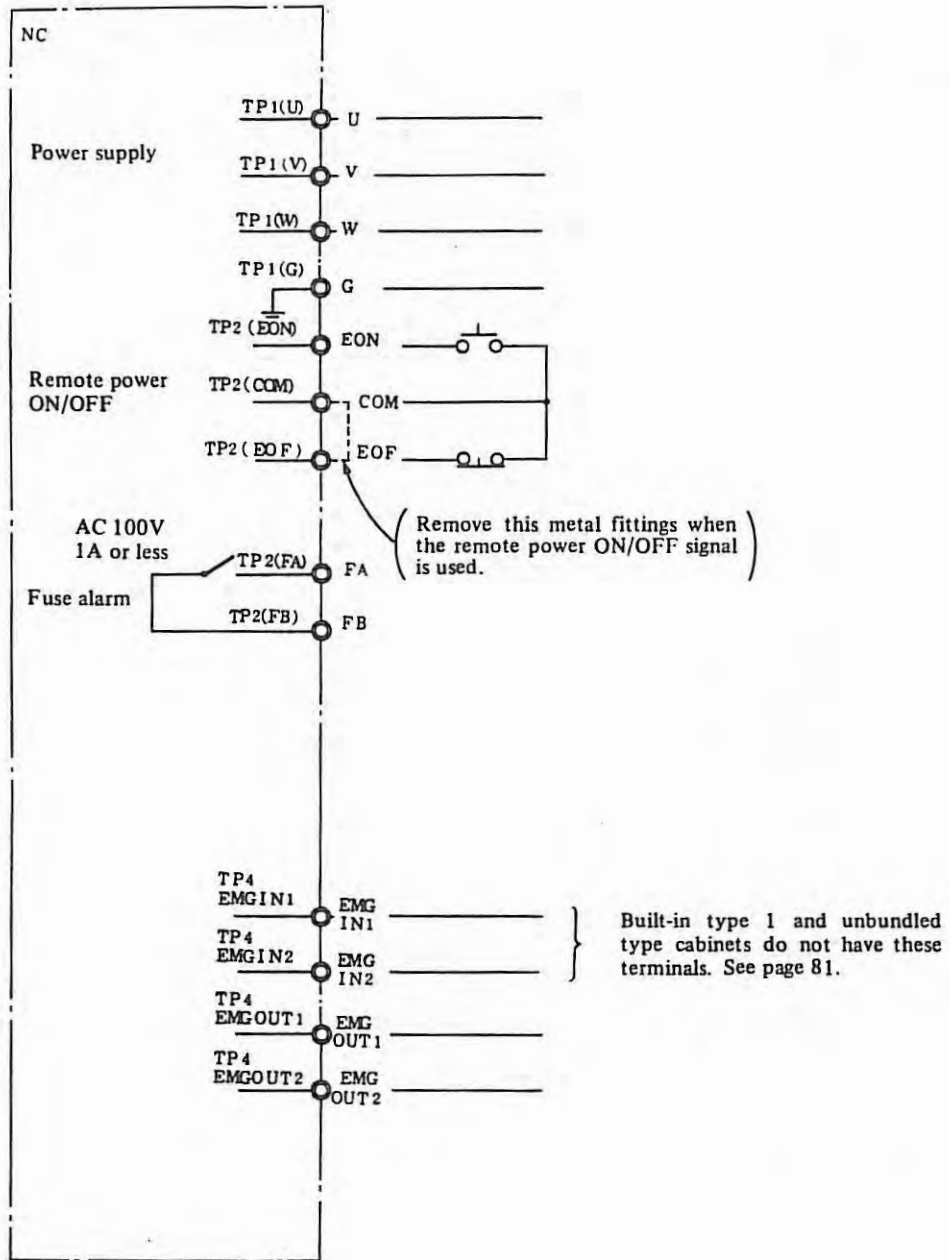

Note: 1. The cable connected to the terminal G should be 5.5 mm^2 or more and the ground resistance should be less than 100Ω .

Appendix 2 Connection between NC and servo motor

NC

X: MR-20RMA

1	2	3	4	5	6	7
0v	0v	0v	+5v	+5v	+5v	
8	9	10	11	12	13	
OH1X	OH2X					
14	15	16	17	18	19	20
PCZX	*PCZA	PCAX	*PCAX	PCBX	*PCBX	0G

X-axis

X-T1: M4 screw terminal

5	6	7	8
A1X	A1X	A2X	A2X

Y/Z: MR-20RMA

1	2	3	4	5	6	7
0v	0v	0v	+5v	+5v	+5v	
8	9	10	11	12	13	
OH1Z	OH2Z					
14	15	16	17	18	19	20
PCZZ	*PCZZ	PCAZ	*PCAZ	PCBZ	*PCBZ	0G

Z-axis

Z-T1: M4 screw terminal

5	6	7	8
A1Z	A1Z	A2Z	A2Z

T: MR-20RMA 1A

1	2	3	4	5	6	7
0v	0v	0v	+5v	+5v	+5v	
8	9	10	11	12	13	
OH1T	OH2T					
14	15	16	17	18	19	20
PCZT	*PCZT	PCAT	*PCAT	PCBT	*PCBT	0G

T-axis

TX-T1: M4 screw terminal

5	6	7	8
A1T	A1T	A2T	A2T

C: MR-20RMA

1	2	3	4	5	6	7
0v	0v	0v	+5v	+5v	+5v	
8	9	10	11	12	13	
OH1C	OH2C					
14	15	16	17	18	19	20
PCZC	*PCZC	PCAC	*PCAC	PCBC	*PCBC	

C-axis

C-T1: M4 screw terminal

5	6	7	8
A1C	A1C	A2C	A2C

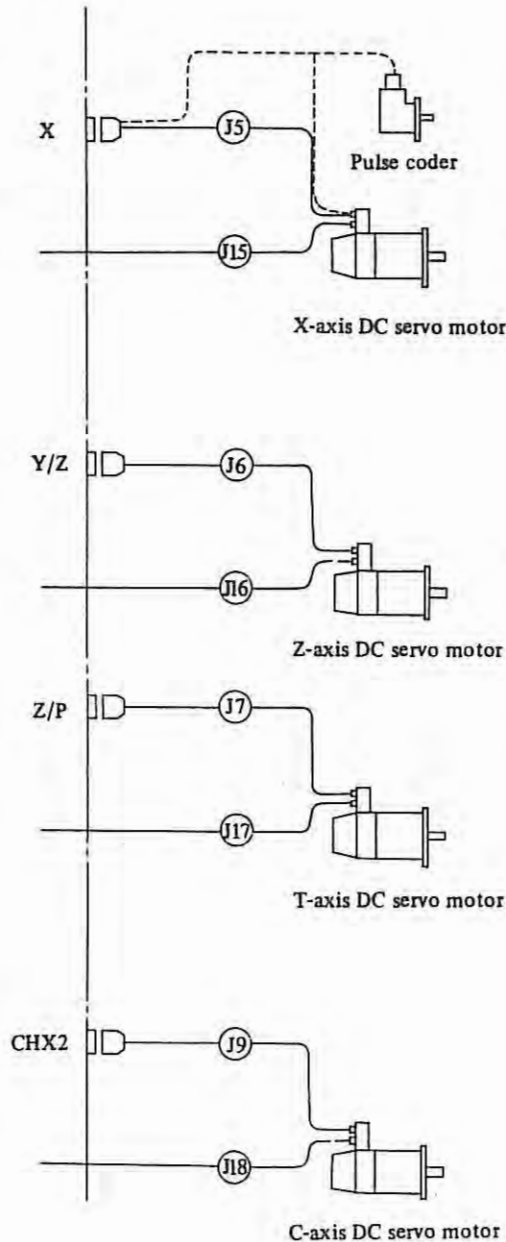

C-axis DC servo motor

Interface circuit for servo motor with pulse coder

MS3102A-20-29P

A	B	C	D	E	F
PCA α	PCB α	+5v	*PCA α	*PCB α	PCZ α
G	H	J	K	L	M
*PCZ α	0G	+5v	+5v		
N	P	R	S	T	
0v	0v	OH1 α	OH2 α	0v	

MS3102A-18-10P

A	B
A1 α	A2 α
C	D

Pulse coder incorporated type

MS3102-20-29P

A	B	C	D	E	F
PCA α	PCB α	+5v	*PCA α	*PCB α	PCZ α
G	H	J	K	L	M
*PCZ α	0G	+5v	+5v		
N	P	R	S	T	
0v	0v	OH1 α	OH2 α	0v	

MS3102A-28-20P

A	B	C	D	E
		A1A α	A1B α	
F	G	H	J	K
AZA α	A2B α			BCA α
L	M	N	P	
BCB α				

Cannon connector

G1	G2	G3	OTL1	OTL2	R1	R2	S1	S2	S3	S4
TSA α	TSB α	0G	OH1 α	OH2 α						

Screw terminal

α : X, Z, T, C

Note: Allowable cable length is up to 14 meter. If a cable longer than that needs to use, consult us beforehand.

MS3102A-20-29P

A	B	C	D	E	F
PCA α	PCB α	+5v	*PCA α	*PCB α	PCZ α
G	H	J	K	L	M
*PCZ α	0G	+5v	+5v		
N	P	R	S	T	
0v	0v			0v	

MS3102A-18-10P

A	B
A1 α	A2 α
C	D

MS3102A-20-29P

A	B	C	D	E	F
TSA α	TSB α				
G	H	J	K	L	M
	0G				
N	P	R	S	T	
		OH1 α	OH2 α		

Pulse coder separate type

MS3102A-20-29P

A	B	C	D	E	F
PCA α	PCB α	+5v	*PCA α	*PCB α	PCZ α
G	H	J	K	L	M
*PCZ α	0G	+5v	+5v		
N	P	R	S	T	
0v	0v			0v	

A1	A1	A2	A2	B1	B2
A1A α	A1B α	A2A α	A2B α	BCA α	BCB α

To control panel

C31: MR20RM

1	2	3	4	5	6	7
OH1X	OH2X				TSAY	TSBX
8	9	10	11	12	13	
14	15	16	17	18	19	20
DSAX	DSBX	DCAX	DCBX	RSBX	RSAX	

X-T1: M4 screw terminal

5	6	7	8
A1AX	A1BX	A2AX	A2BX

C34: MR20RM

1	2	3	4	5	6	7
OH1Z	OH2Z				TSAZ	TSBZ
8	9	10	11	12	13	
14	15	16	17	18	19	20
DSAZ	DSBZ	DCAZ	DCBZ	RSBZ	RSAZ	

Z-T1: M4 screw terminal

5	6	7	8
A1AZ	A1BZ	A2AZ	A2BZ

C37: MR20RM

1	2	3	4	5	6	7
OH1T	OH2T				TSAT	TSBT
8	9	10	11	12	13	
14	15	16	17	18	19	20
DSAT	DSBT	DCAT	DCBT	RSBT	RSAT	

T-T1: M4 screw terminal

5	6	7	8
A1AT	A1BT	A2AT	A2BT

C40: MR20RM

1	2	3	4	5	6	7
OH1C	OH2C				TSAC	TSBC
8	9	10	11	12	13	
14	15	16	17	18	19	20
DSAC	DSBC	DCAC	DCBC	RSBC	RSAC	

C-T1: M4 screw terminal

5	6	7	8
A1AC	A1BC	A2AC	A2BC

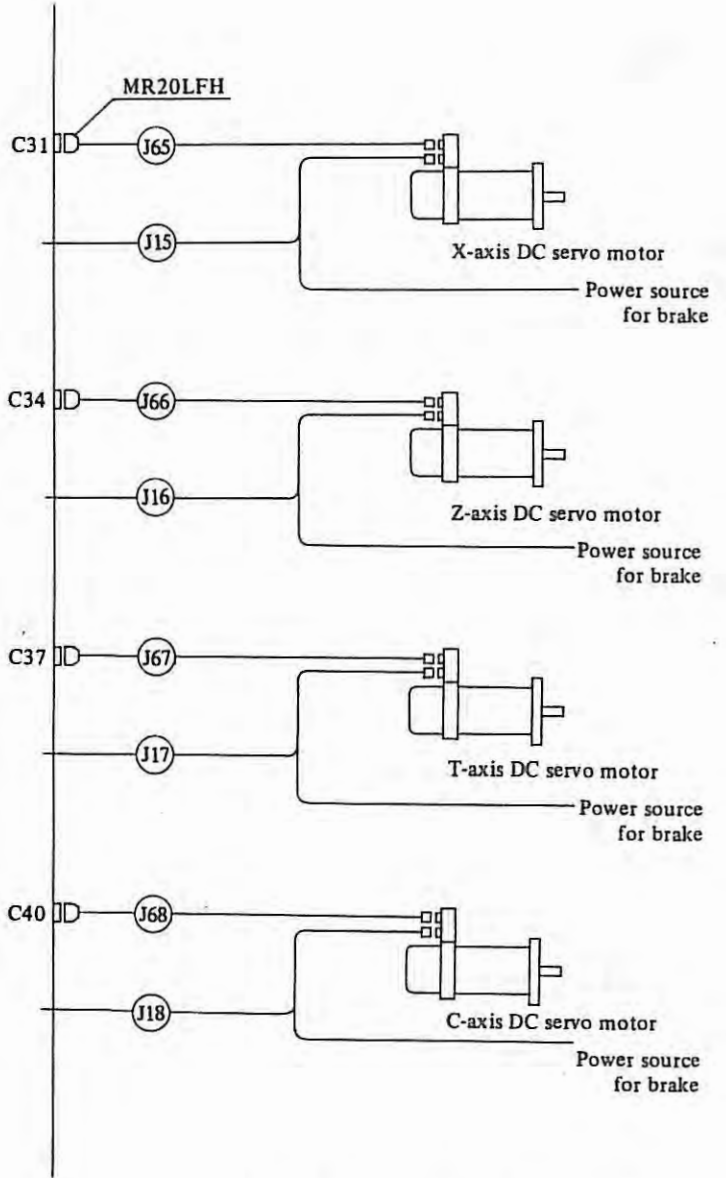

Note: Allowable cable length is up to 50m. If a cable longer than that needs to use, consult us beforehand.

Interface Circuit for Servo Motor with Resolver

C33: RM12BRB-7S

1	2	3	4	5	6	7
				+5V	RSAX	RSBX

C32: RM12BRB-7S

1	2	3	4	5	6	7
DCAX	DCBX	DSBX	DSAX			

C31: MR20RM

1	2	3	4	5	6	7
OH1X	OH2X				TSAX	TSBX
8	9	10	.11	12	13	
14	15	16	17	18	19	20

C36: RM12BRB-7S

1	2	3	4	5	6	7
				+5V	RSAZ	RSBZ

C35: RM12BRB-7S

1	2	3	4	5	6	7
DCAZ	DCBZ	DSBZ	DSAZ			

C34: MR20RM

1	2	3	4	5	6	7
OH1Z	OH2Z				TSAZ	TSBZ
8	9	10	11	12	13	
14	15	16	17	18	19	20

C39: RM12BRB-7S

1	2	3	4	5	6	7
				+5V	RSAT	RSBT

C38: RM12BRB-7S

1	2	3	4	5	6	7
DCAT	DCBT	DSBT	DSAT			

C37: MR20RM

1	2	3	4	5	6	7
OH1T	OH2T				TSAT	TSBT
8	9	10	11	12	13	
14	15	16	17	18	19	20

C42: RM12BRB-7S

1	2	3	4	5	6	7
				+5V	RSAC	RSBC

C41: RM12BRB-7S

1	2	3	4	5	6	7
DCAC	DCBC	DSBC	DSAC			

C40: MR20RM

1	2	3	4	5	6	7
OH1C	OH2C				TSAC	TSBC
8	9	10	11	12	13	
14	15	16	17	18	19	20

B1: RM15WTRA-8S

1	2	3	4	5	6	7	8
				+5V	ERRS	ERRM	

X-T1:

M4 Screw terminal

5	6	7	8
A1AX	A1BX	A2AX	A2BX

Z-T1:

M4 Screw terminal

5	6	7	8
A1AZ	A1BZ	A2AZ	A2BZ

T-T1:

M4 Screw T

5	6	7	8
A1AT	A1BT	A2AT	A2BT

C-T1:

M4 Screw terminal

5	6	7	8
A1AC	A1BC	A2AC	A2BC

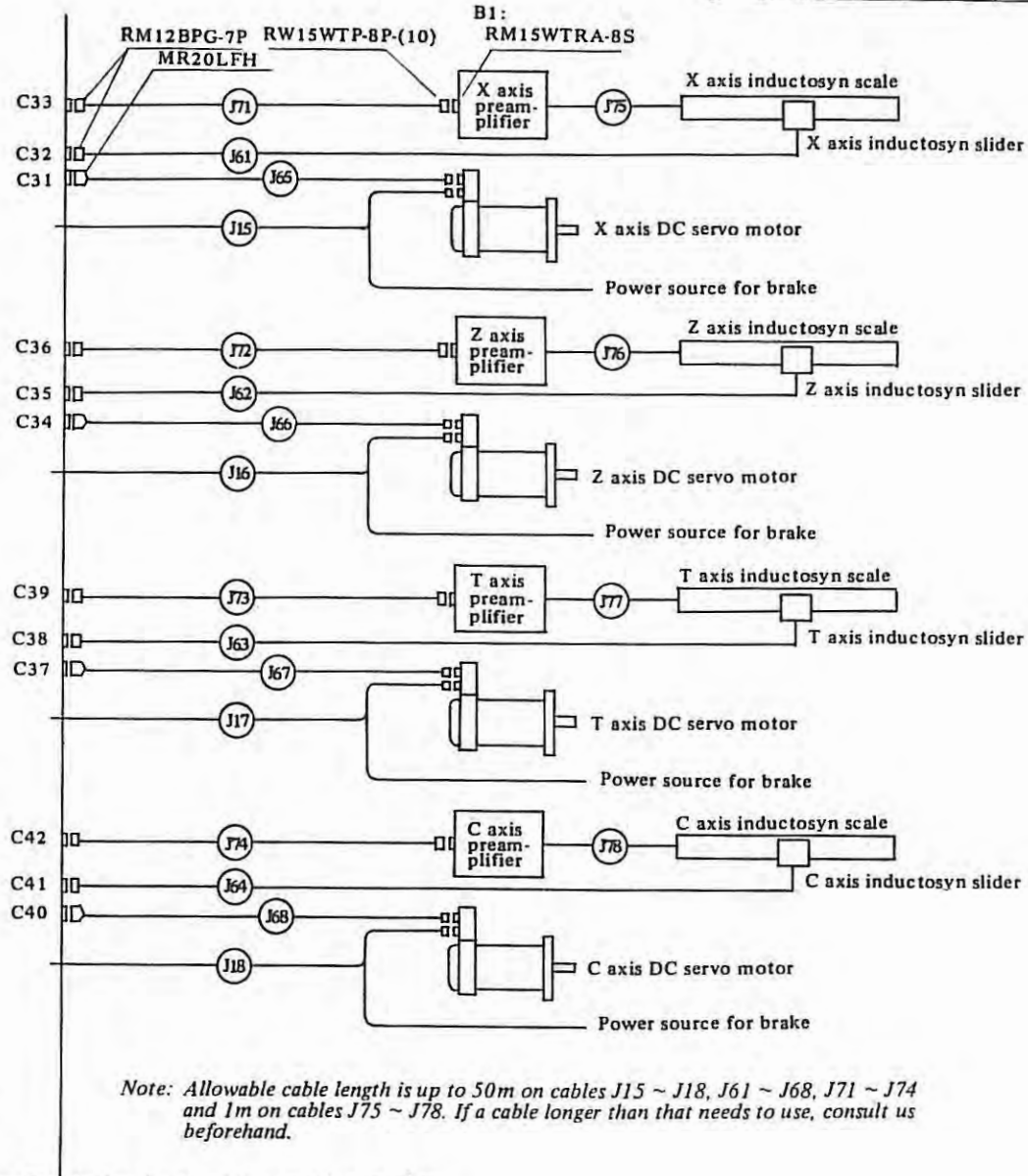

Note: Allowable cable length is up to 50m on cables J15 ~ J18, J61 ~ J68, J71 ~ J74 and 1m on cables J75 ~ J78. If a cable longer than that needs to use, consult us beforehand.

Interface Circuit for Servo Motor and Inductosyn

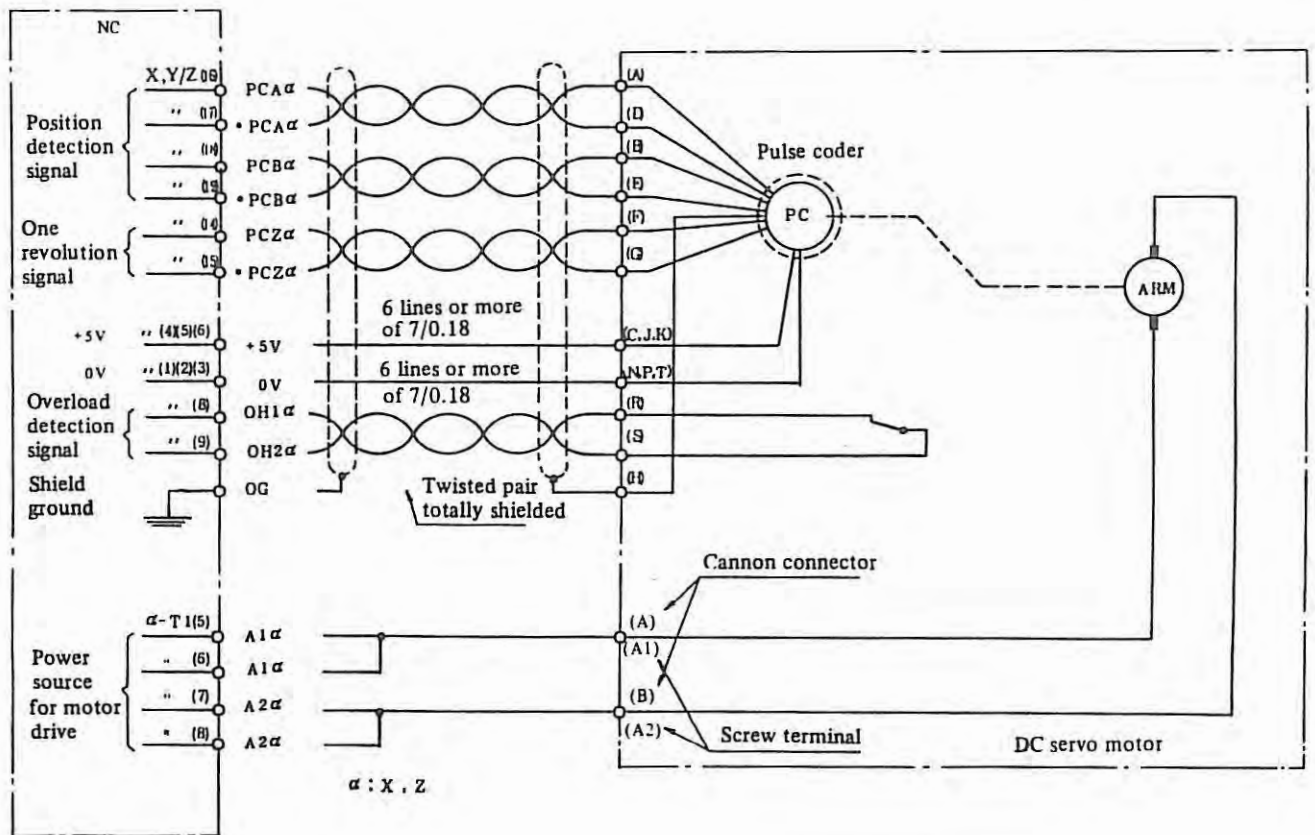

MODEL 0 and 5, Pulse coder incorporated type

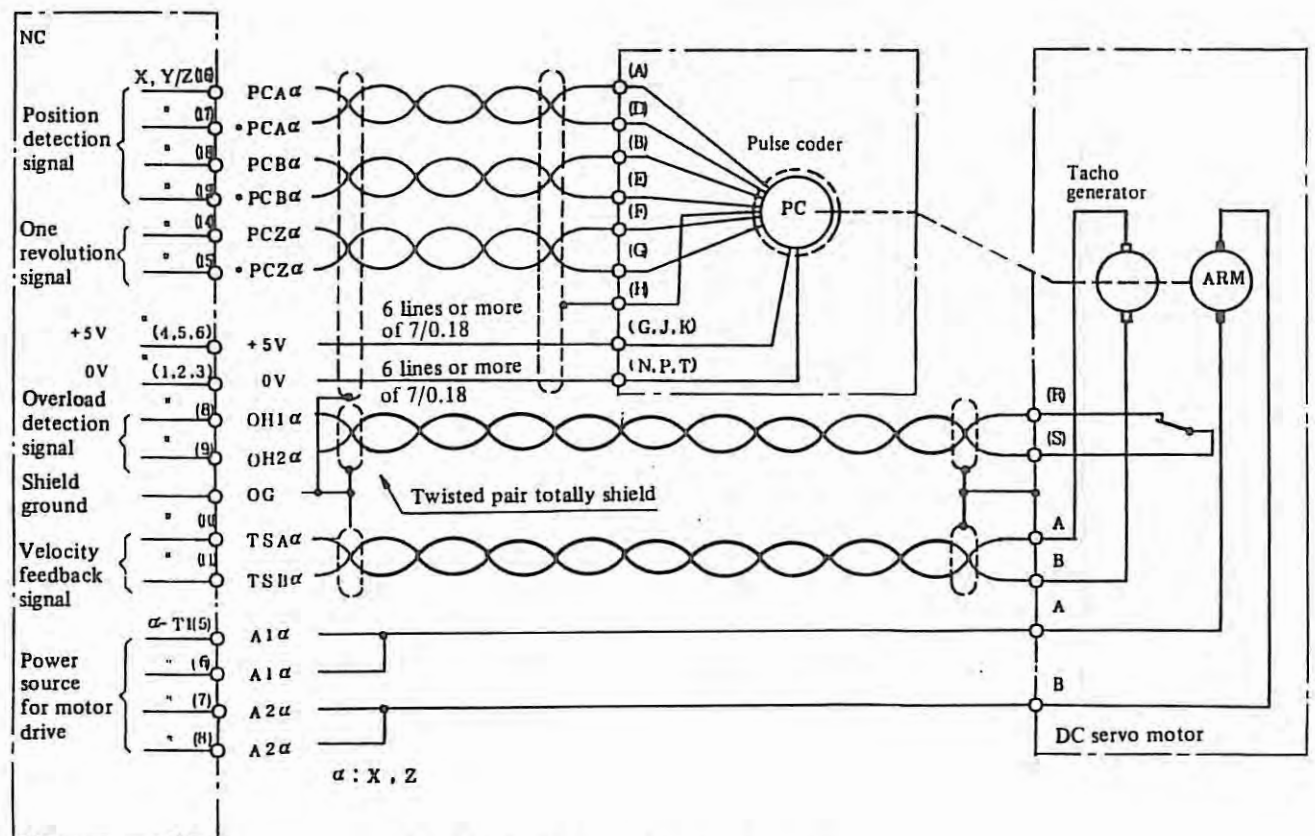

MODEL 0, 5 Pulse coder separate type

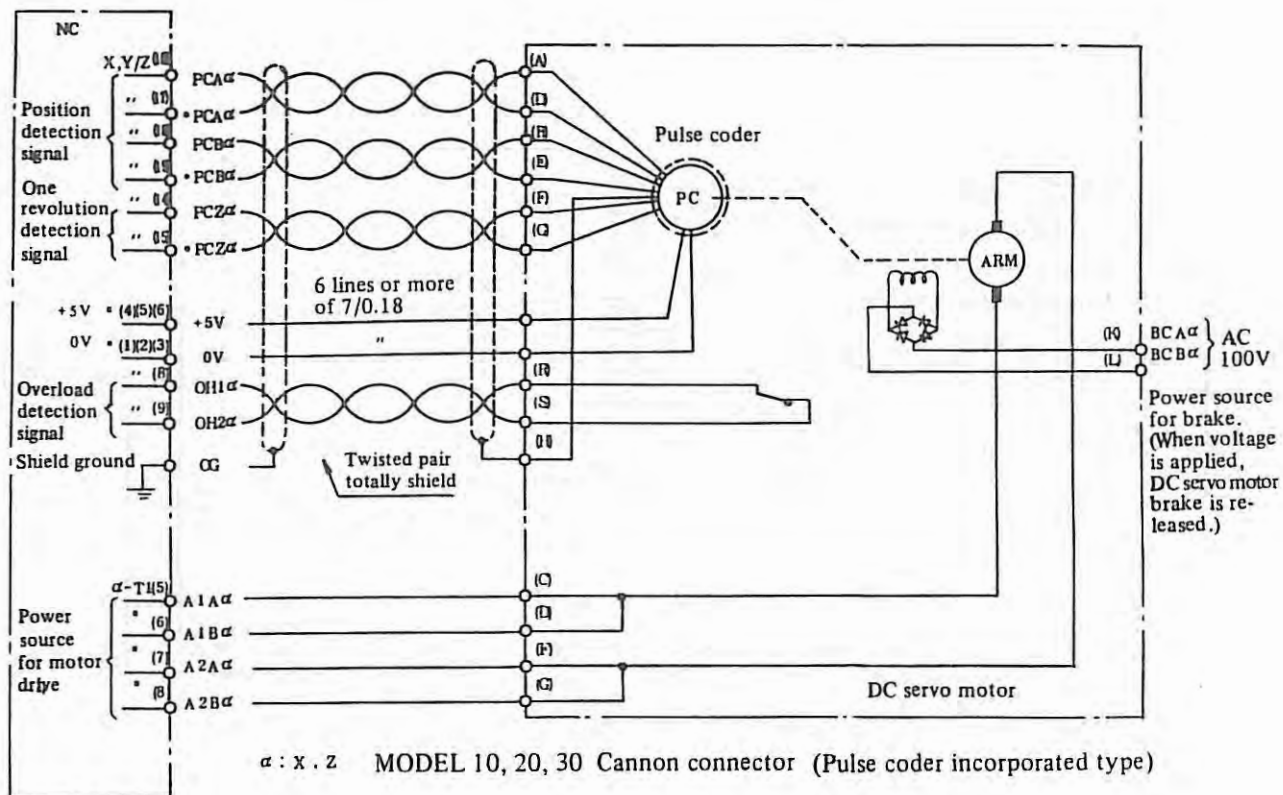
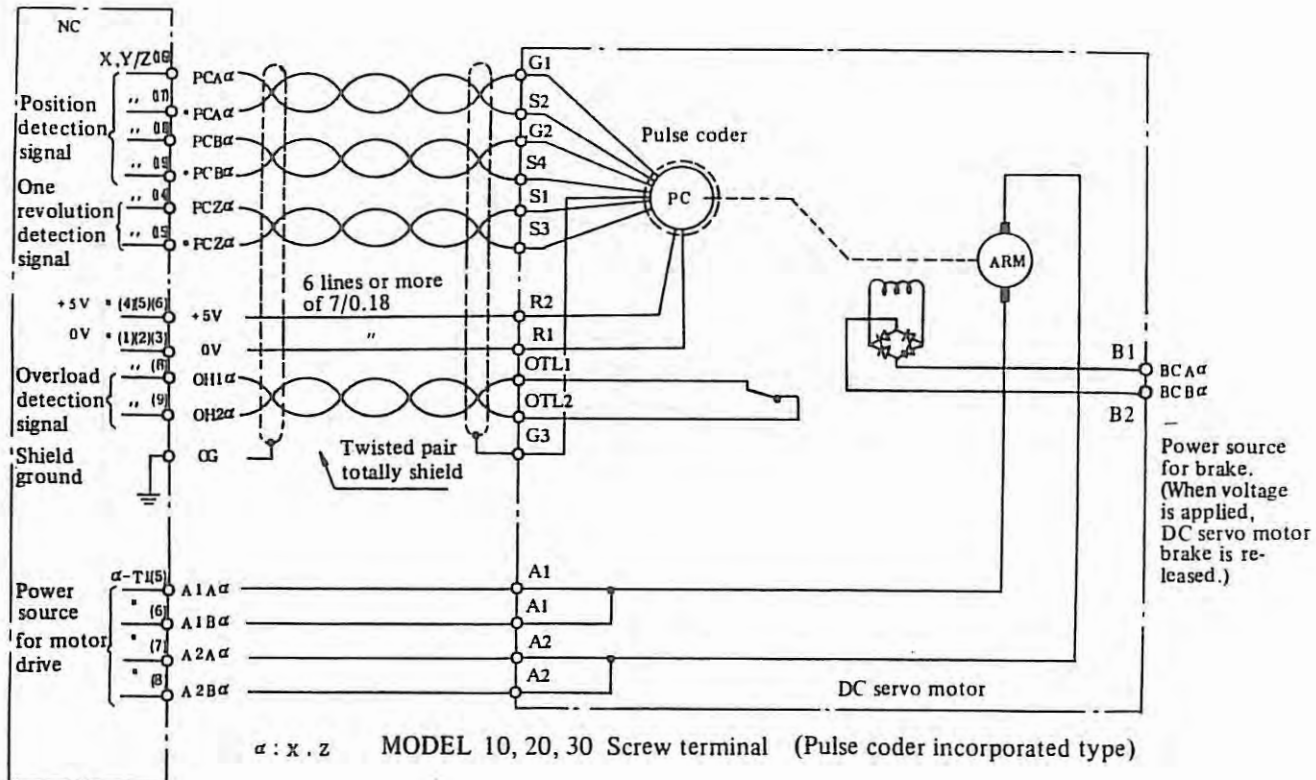

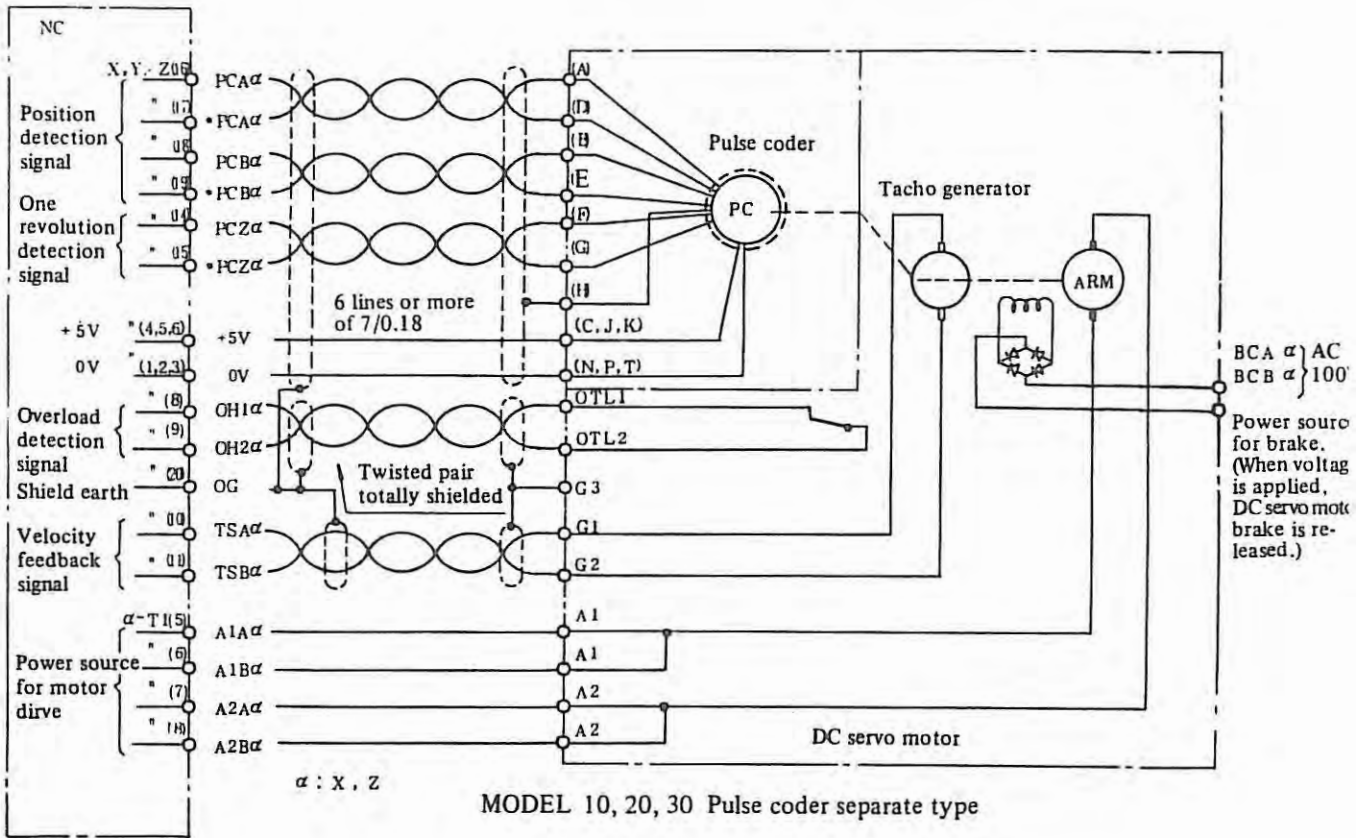

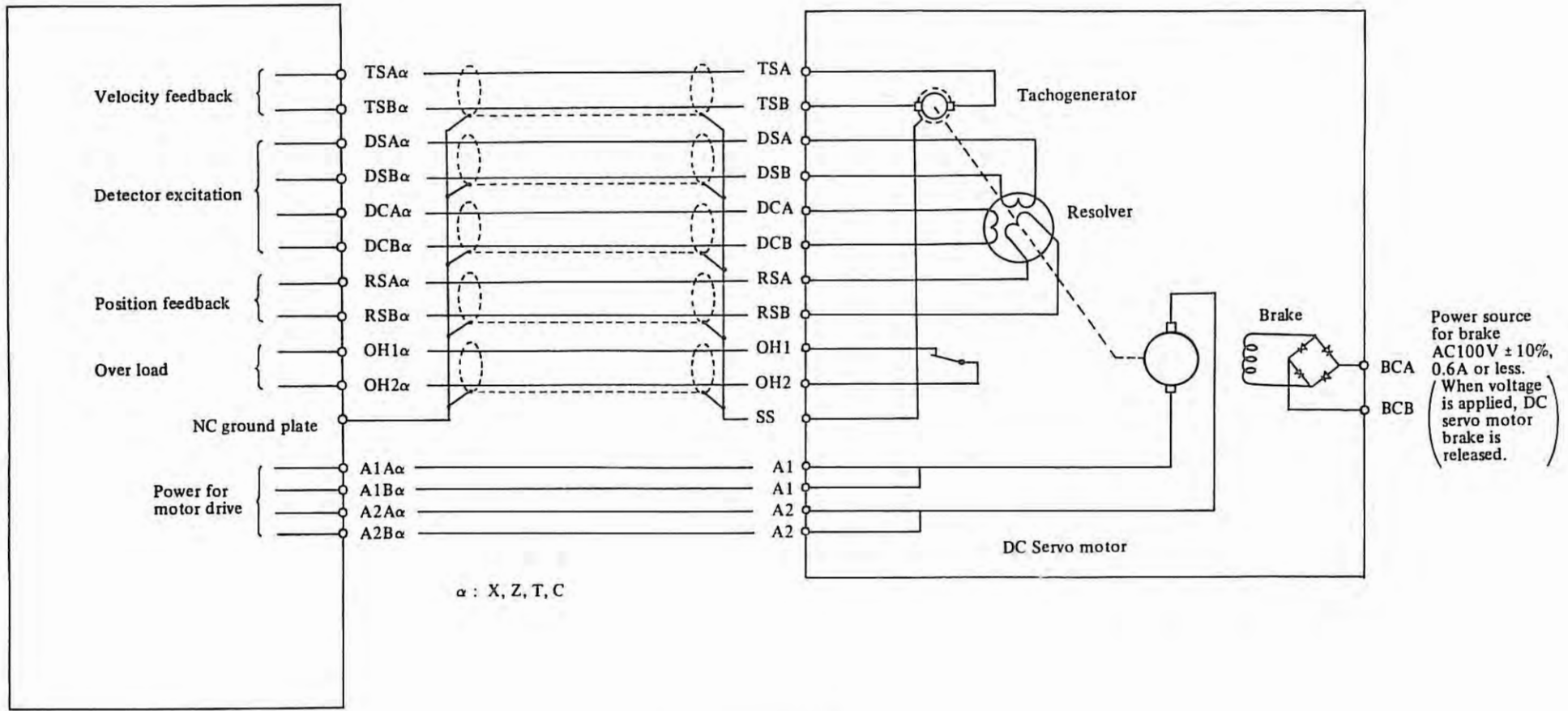

α : X, Z, T, C

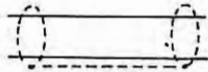

2 cores, twisted pair shielded wire, 0.5 mm²

Connection of servo motor with resolver

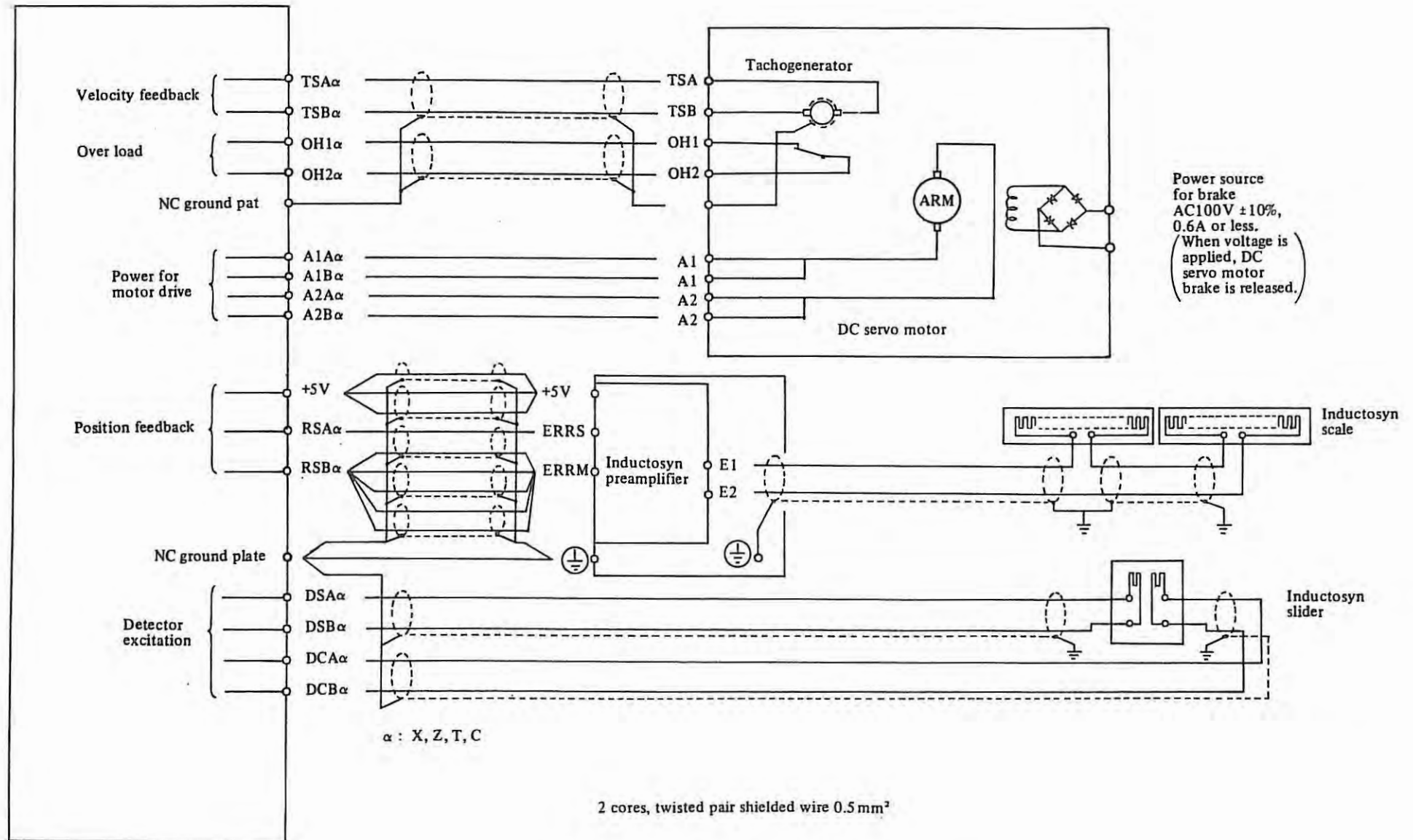

Connection of servo motor and inductosyn scale

2. FOR M series

2.1 Pulse Coder Feedback (pulse coder separate type)

When pulse coder (separate type) use

X: MR-20RMA

1	2	3	4	5	6	7
OV	OV	OV	+5V	+5V	+5V	
8	9	10	11	12	13	
OH1X	OH2X	TSAX	TSBX			
14	15	16	17	18	19	20
PCZX	*PCZX	PCAX	*PCAX	PCBX	*PCBX	OG

X-T1: M4 Screw terminal

5	6	7	8
A1X	A1X	A2X	A2X

G: M4

G
G

Y/Z: MR-20RMA

1	2	3	4	5	6	7
OV	OV	OV	+5V	+5V	+5V	
8	9	10	11	12	13	
OH1Y	OH2Y	TSAY	TSBY			
14	15	16	17	18	19	20
PCZY	*PCZY	PCAY	*PCAY	PCBY	*PCBY	OG

Y-T1: M4 Screw terminal

5	6	7	8
A1Y	A1Y	A2Y	A2Y

G: M4

G
G

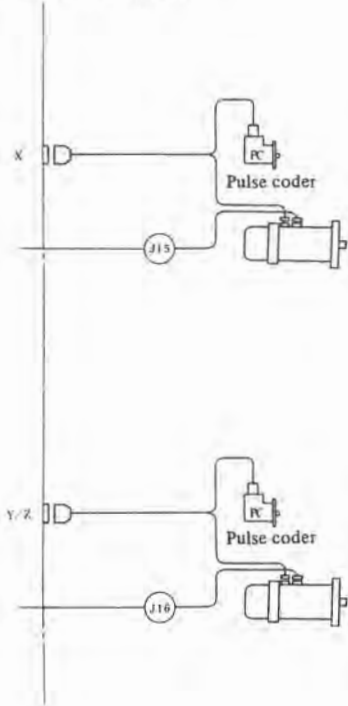

For 00M

MS3102A-20-29P

A	B	C	D	E	F
PCAX	PCBX	+5V	*PCAX	*PCBX	PCZX
G	H	J	K	L	M
*PCZX	OG	+5V	+5V		
N	P	R	S	T	
OV	OV			OV	

RM15WTR-4P

1	2
A1X	A2X
3	4
G	

RM15WTR-10P

1	2	3	4	5
TSAX	TSBX	OG		
6	7	8	9	10
		OH1X	OH2X	

MS3102A-20-29P

A	B	C	D	E	F
PCAY	PCBY	+5V	*PCAY	*PCBY	PCZY
G	H	J	K	L	M
*PCZY	OG	+5V	+5V		
N	P	R	S	T	
OV	OV			OV	

RM15WTR-4P

1	2
A1Y	A2Y
3	4
G	

RM15WTR-10P

1	2	3	4	5
TSAY	TSBY	OG		
6	7	8	9	10
		OH1Y	OH2Y	

For 0M, 5M

MS3102A-20-29P

A	B	C	D	E	F
PCAX	PCBX	+5V	*PCAX	*PCBX	PCZX
G	H	J	K	L	M
*PCZX	OG	+5V	+5V		
N	P	R	S	T	
OV	OV			OV	

MS3102A-18-10P

A	B
A1X	A2X
C	D
G	

MS3102A-20-29P

A	B	C	D	E	F
TSAX	TSBX				
G	H	J	K	L	M
N	P	R	S	T	
		OH1X	OH2X		

MS3102A-20-29P

A	B	C	D	E	F
PCAY	PCBY	+5V	*PCAY	*PCBY	PCZY
G	H	J	K	L	M
*PCZY	OG	+5V	+5V		
N	P	R	S	T	
OV	OV			OV	

MS3102A-18-10P

A	B
A1Y	A2Y
C	D
G	

MS3102A-20-29P

A	B	C	D	E	F
TSAY	TSBY				
G	H	J	K	L	M
N	P	R	S	T	
		OH1Y	OH2Y		

For 10M, 20M, 30M

MS3102A-20-29P

A	B	C	D	E	F
PCAX	PCBX	+5V	*PCAX	*PCBX	PCZX
G	H	J	K	L	M
*PCZX	OG	+5V	+5V		
N	P	R	S	T	
OV	OV			OV	

MS3102A-28-20P

A	B	C	D	E	F
		A1X	A1X		A2X
G	H	J	K	L	M
A2X			BCAX	BCBX	
N	P				

MS3102A-20-29P

A	B	C	D	E	F
TSAX	TSBX				
G	H	J	K	L	M
N	P	R	S	T	
		OH1X	OH2X		

MS3102A-20-29P

A	B	C	D	E	F
PCAY	PCBY	+5V	*PCAY	*PCBY	PCZY
G	H	J	K	L	M
*PCZY	OG	+5V	+5V		
N	P	R	S	T	
OV	OV			OV	

MS3102A-28-20P

A	B	C	D	E	F
		A1Y	A1Y		A2Y
G	H	J	K	L	M
A2Y			BCAY	BCBY	
N	P				

MS3102A-20-29P

A	B	C	D	E	F
TSAY	TSBY				
G	H	J	K	L	M
N	P	R	S	T	
		OH1Y	OH2Y		

2.2 Pulse coder Feedback (pulse coder incorporate type)

When resolver use

X: MR-20RMA

1	2	3	4	5	6	7
OV	OV	OV	+5V	+5V	+5V	
8	9	10	11	12	13	
OH1X	OH2X					
14	15	16	17	18	19	20
PCZX	*PCZX	PCAX	*PCAX	PCBX	*PCBX	OG

G: M4

G
G

X-T1: M4 Screw terminal

5	6	7	8
A1AX	A1BX	A2AX	A2BX

Y/Z: MR-20RMA

1	2	3	4	5	6	7
OV	OV	OV	+5V	+5V	+5V	
8	9	10	11	12	13	
OH1Y	OH2Y					
14	15	16	17	18	19	20
PCZY	*PCZY	PCAY	*PCAY	PCBY	*PCBY	OG

G: M4

G
G

Y-T1: M4 Screw terminal

5	6	7	8
A1AY	A1BY	A2AY	A2BY

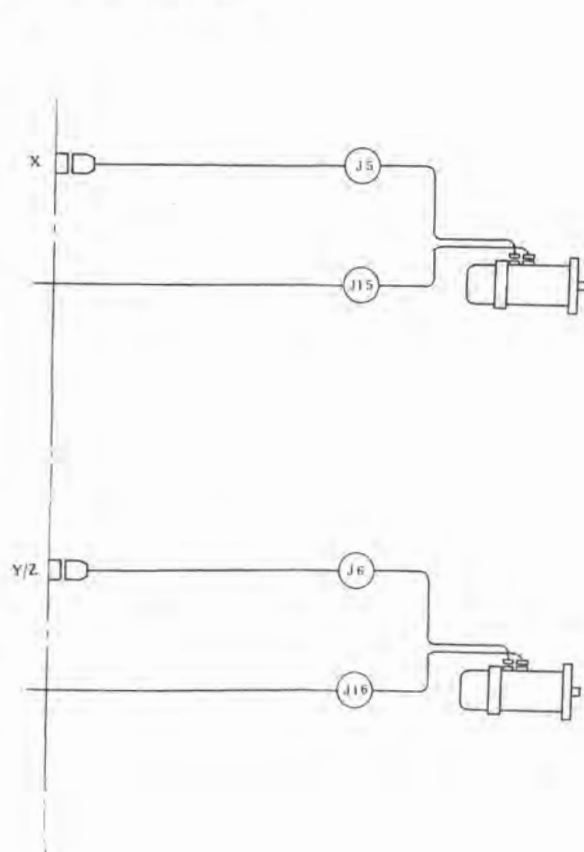

For 00M

MS3102A-20-29P

A	B	C	D	E	F
PCAX	PCBX	+5V	*PCAX	*PCBX	PCZX
G	H	J	K	L	M
*PCZX	OG	+5V	+5V		
N	P	R	S	T	
OV	OV	OH1X	OH2X	OV	

RM15WTR-4P

1	2
A1X	A2X
3	4
G	

MS3102A-20-29P

A	B	C	D	E	F
PCAY	PCBY	+5V	*PCAY	*PCBY	PCZY
G	H	J	K	L	M
*PCZY	OG	+5V	+5V		
N	P	R	S	T	
OV	OV	OH1Y	OH2Y	OV	

RM15WTR-4P

1	2
A1Y	A2Y
3	4
G	

For 0M, 5M

MS3102A-20-29P

A	B	C	D	E	F
PCAX	PCBX	+5V	*PCAX	*PCBX	PCZX
G	H	J	K	L	M
*PCZX	OG	+5V	+5V		
N	P	R	S	T	
OV	OV	OH1X	OH2X	OV	

MS3102A-18-10P

A	B
A1X	A2X
C	D
G	

MS3102A-20-29P

A	B	C	D	E	F
PCAY	PCBY	+5V	*PCAY	*PCBY	PCZY
G	H	J	K	L	M
*PCZY	OG	+5V	+5V		
N	P	R	S	T	
OV	OV	OH1Y	OH2Y	OV	

MS3102A-18-10P

A	B
A1Y	A2Y
C	D
G	

For 10M, 20M, 30M

MS3102A-20-29P

A	B	C	D	E	F
PCAX	PCBX	+5V	*PCAX	*PCBX	PCZX
G	H	J	K	L	M
*PCZX	OG	+5V	+5V		
N	P	R	S	T	
OV	OV	OH1X	OH2X	OV	

MS3102A-28-20P

A	B	C	D	E	F
		A1X	A1X		A2X
G	H	J	K	L	M
A2X			BCAX	BCBX	
N	P				

MS3102A-20-29P

A	B	C	D	E	F
PCAY	PCBY	+5V	*PCAY	*PCBY	PCZY
G	H	J	K	L	M
*PCZY	OG	+5V	+5V		
N	P	R	S	T	
OV	OV	OH1Y	OH2Y	OV	

MS3102A-28-20P

A	B	C	D	E	F
		A1Y	A1Y		A2Y
G	H	J	K	L	M
A2Y			BCAY	BCBY	
N	P				

2.3 Resolver Feedback

C31: MR20RM

1	2	3	4	5	6	7
OH1X	OH2X				TSAY	TSBY
8	9	10	11	12	13	
14	15	16	17	18	19	20
DSAX	DSBX	DCAX	DCBX	RSBX	RSAX	

X-T1: M4 Screw terminal

5	6	7	8
A1AX	A1BX	A2AX	A2BX

G: M4

G
G

C34: MR20RM

1	2	3	4	5	6	7
OH1Y	OH2Y				TSAY	TSBY
8	9	10	11	12	13	
14	15	16	17	18	19	20
DSAY	DSBY	DCAY	DCBY	RSBY	RSAY	

Y-T1: M4 Screw terminal

5	6	7	8
A1AY	A1BY	A2AY	A2BY

G: M4

G
G

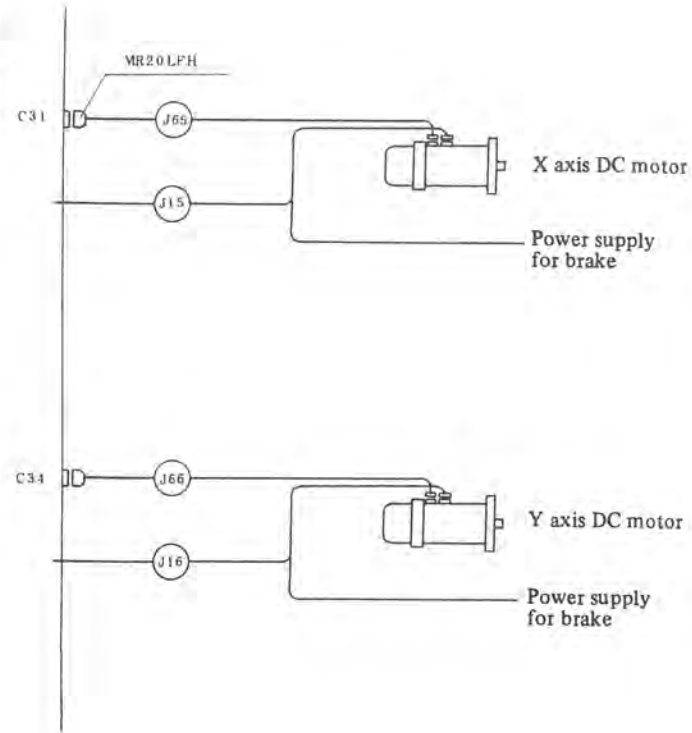

For 00M

RM15WTR-10P

1	2	3	4	5
TSAX	TSBX	DSAX	DSBX	DCAX
6	7	8	9	10
DCBX	RSAX	RSBX	OH1X	OH2X

RM15WTR-4P

1	2
A1X	A2X
3	4
G	

RM15WTR-10P

1	2	3	4	5
TSAY	TSBY	DSAY	DSBY	DCAY
6	7	8	9	10
DCBY	RSAY	RSBY	OH1Y	OH2Y

RM15WTR-4P

1	2
A1Y	A2Y
3	4
G	

For 0M, 5M

MS3102A-20-29P

A	B	C	D	E	F
TSAX	TSBX	J	DSAX	DSBX	DCAX
G	H		K	L	M
DCBX	OG	RSAX	RSBX		
N	P	R	S	T	
		OH1X	OH2X		

MS3102A-18-10P

A	B
A1X	A2X
C	D
G	

MS3102A-20-29P

A	B	C	D	E	F
TSAY	TSBY	J	DSAY	DSBY	DCAY
G	H		K	L	M
DCBY	OG	RSAY	RSBY		
N	P	R	S	T	
		OH1Y	OH2Y		

MS3102A-18-10P

A	B
A1Y	A2Y
C	D
G	

For 10M, 20M, 30M

MS3102A-20-29P

A	B	C	D	E	F
TSAX	TSBX	J	DSAX	DSBX	DCAX
G	H		K	L	M
DCBX	OG	RSAX	RSBX		
N	P	R	S	T	
		OH1X	OH2X		

MS3102A-28-20P

A	B	C	D	E	F
		A1X	A1X		A2X
G	H	J	K	L	M
A2X			BCAX	BCBX	
N	P				
	G				

MS3102A-20-29P

A	B	C	D	E	F
TSAY	TSBY	J	DSAY	DSBY	DCAY
G	H		K	L	M
DCBY	OG	RSAY	RSBY		
N	P	R	S	T	
		OH1Y	OH2Y		

MS3102A-28-20P

A	B	C	D	E	F
		A1Y	A1Y		A2Y
G	H	J	K	L	M
A2Y			BCAY	BCBY	
N	P				
	G				

2.4 Inductosyn Feedback

When inductosyn use

C33: RM12BRB-7S

1	2	3	4	5	6	7
				+5V	RSAX	RSBX

C32: RM12BRB-7S

1	2	3	4	5	6	7
DCAX	DCBX	DSBX	DSAX			

C31: MR20RM

1	2	3	4	5	6	7
OH1X	OH2X				TSAX	TSBX
8	9	10	11	12	13	
14	15	16	17	18	19	20

X-T1: M4 Screw terminal

5	6	7	8
A1AX	A1BX	A2AX	A2BX

G: M4

G
G

C36: RM12BRB-7S

1	2	3	4	5	6	7
				+5V	RSAY	RSBY

C35: RM12BRB-7S

1	2	3	4	5	6	7
DCAY	DCBY	DSBY	DSAY			

C34: MR20RM

1	2	3	4	5	6	7
OH1Y	OH2Y				TSAY	TSBY
8	9	10	11	12	13	
14	15	16	17	18	19	20

Y-T1: M4 Screw terminal

5	6	7	8
A1AY	A1BY	A2AY	A2BY

G: M4

G
G

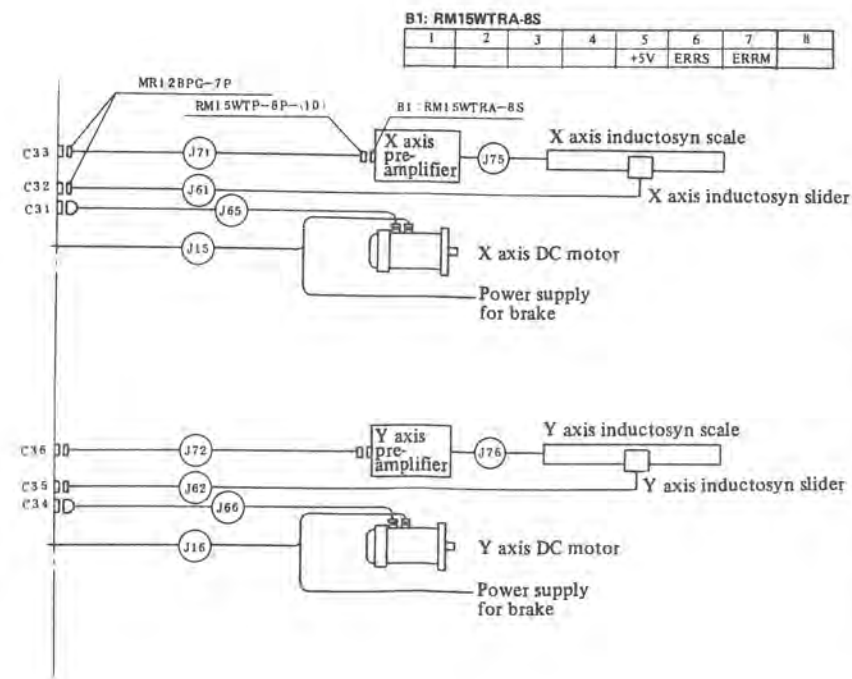

For 00M

RM15WTR-10P

1	2	3	4	5
TSAX	TSBX	OG		
6	7	8	9	10
		OH1X	OH2X	

RM15WTR-4P

1	2
A1X	A2X
3	4
G	

RM15WTR-10P

1	2	3	4	5
TSAY	TSBY	OG		
6	7	8	9	10
		OH1Y	OH2Y	

RM15WTR-4P

1	2
A1Y	A2Y
3	4
G	

For 0M, 5M

MS3102A-20-29P

A	B	C	D	E	F
TSAX	TSBX	J			
G	H		K	L	M
		OG			
N	P	R	S	T	
		OH1X	OH2X		

MS3102A-18-10P

A	B
A1X	A2X
C	D
G	

MS3102A-20-29P

A	B	C	D	E	F
TSAY	TSBY	J			
G	H		K	L	M
		OG			
N	P	R	S	T	
		OH1Y	OH2Y		

MS3102A-18-10P

A	B
A1Y	A2Y
C	D
G	

For 10M, 20M, 30M

MS3102A-20-29P

A	B	C	D	E	F
TSAX	TSBX	J			
G	H		K	L	M
		OG			
N	P	R	S	T	
		OH1X	OH2X		

MS3102A-28-20P

A	B	C	D	E	F
		A1X	A1X		A2X
G	H	J	K	L	M
A2X			BCAX	BCBX	
N	P				
	G				

MS3102A-20-29P

A	B	C	D	E	F
TSAY	TSBY	J			
G	H		K	L	M
		OG			
N	P	R	S	T	
		OH1Y	OH2Y		

MS3102A-28-20P

A	B	C	D	E	F
		A1Y	A1Y		A2Y
G	H	J	K	L	M
A2Y			BCAY	BCBY	
N	P				
	G				

Appendix 3 Detailed description of power stabilizing unit

1. Location of I/O terminals and ratings

Location of I/O terminals is as follows:

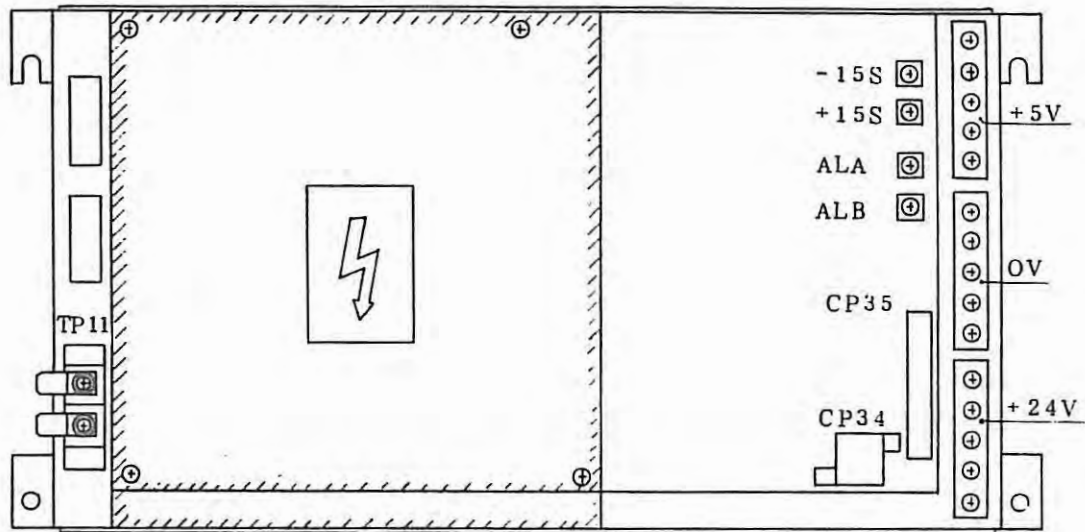

(1) AC input terminals and their ratings

TP11-1 } AC 200V $\begin{matrix} +10 \\ -15 \end{matrix}$ %, 50 or 60 Hz
 or
 TP11-2 } AC 220V $\begin{matrix} +10 \\ -15 \end{matrix}$ %, 50 or 60 Hz

(2) Output terminals and their ratings

Terminal name	Nominal voltage	Allowable range	Use
+5V	+5V	±5%	Logic circuit Reed relay
+24V	+24V	±10%	Tape reader Bubble memory, CRT D/I signals
CP35-1 +15S	+15V	±5%	Position control circuit
CP35-6 -15S	-15V	±5%	Position control circuit, bubble memory
CP35-2, 5 0V	0V	-	

(3) Descriptions of input signals

① Power on/off preceding signal

This signal is given from the input unit through contacts preceding the AC input which is input by the normal power on/off button (NC on/off button or external on/off button).

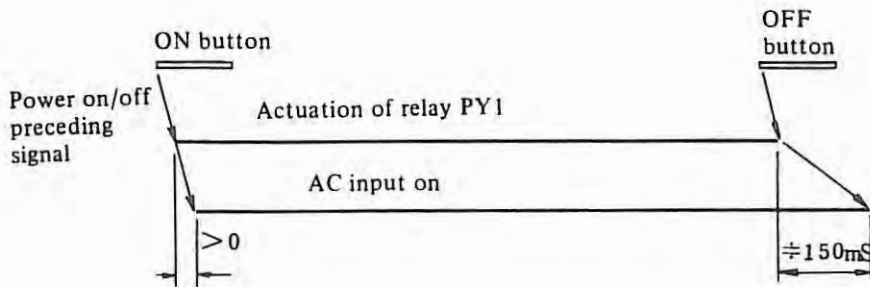
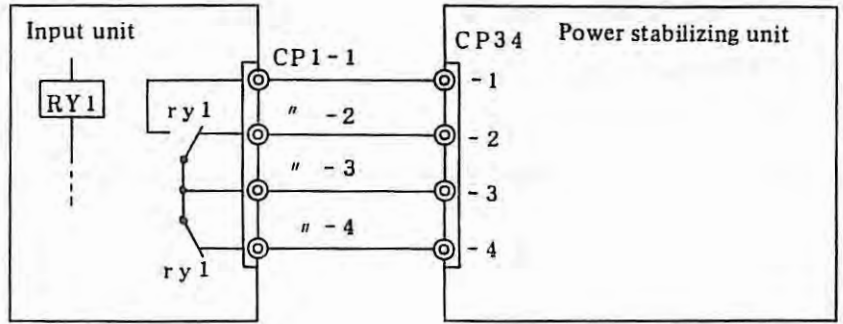

- ② External alarm input signal
The power stabilizing unit receives alarm signals from outside (for example from additional power source) and does the same processes as for the alarms generated in the power stabilizing unit.

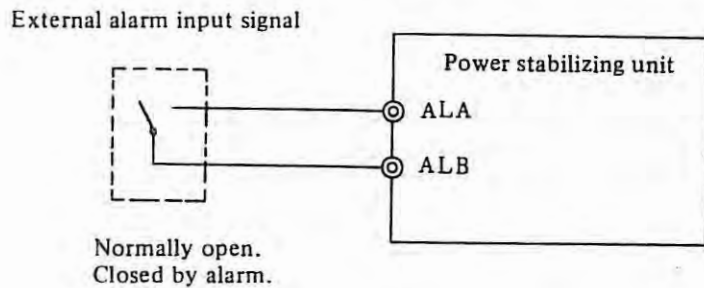

(4) Descriptions of output signals

- ① ENABLE signal (EN)
This is the TTL logical level signal to indicate whether all DC outputs are being issued normally or not. This signal becomes Low when an output abnormality is detected in any circuits or when the power stabilizing unit receives an external alarm.

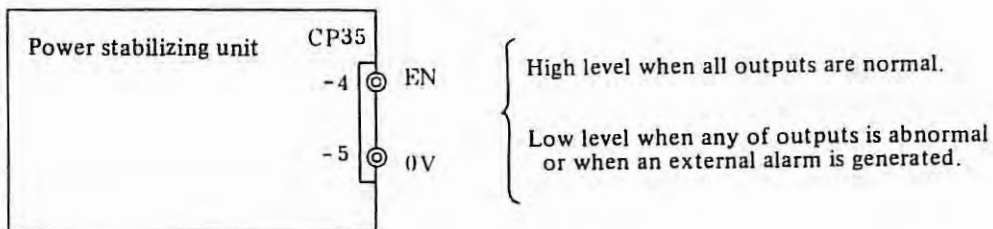

- ② POWER OFF signal (*PF)
This is the TTL logical level signal produced from the power on/off preceding signal.

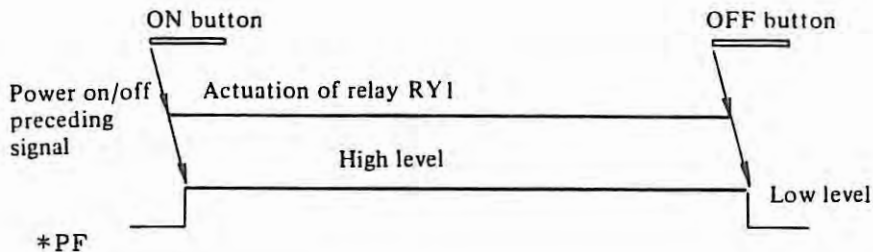
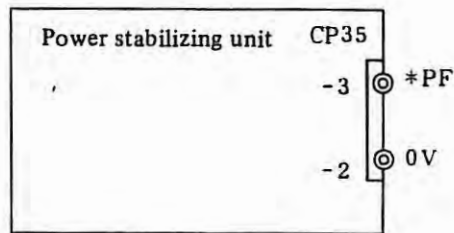

③

Alarm signal

This signal is output through contacts to the input unit when the signal EN becomes Low level or the power stabilizing unit receives an external alarm signal in the output abnormality detection range which is shown in the time chart below.

If this signal is output, the signal is held by a relay inside the input unit and AC power is cut off. (Power OFF due to alarm).

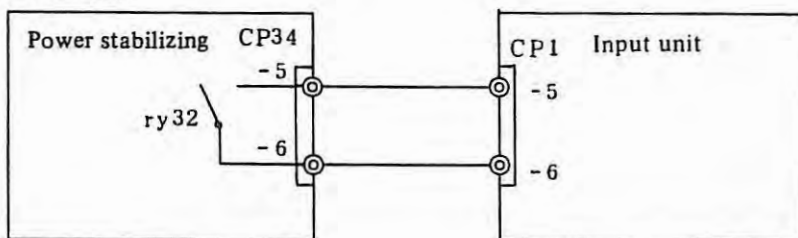

Normally open
Closed by alarm

When RY32 operated, Relay AL make on and ALM lamp light on.

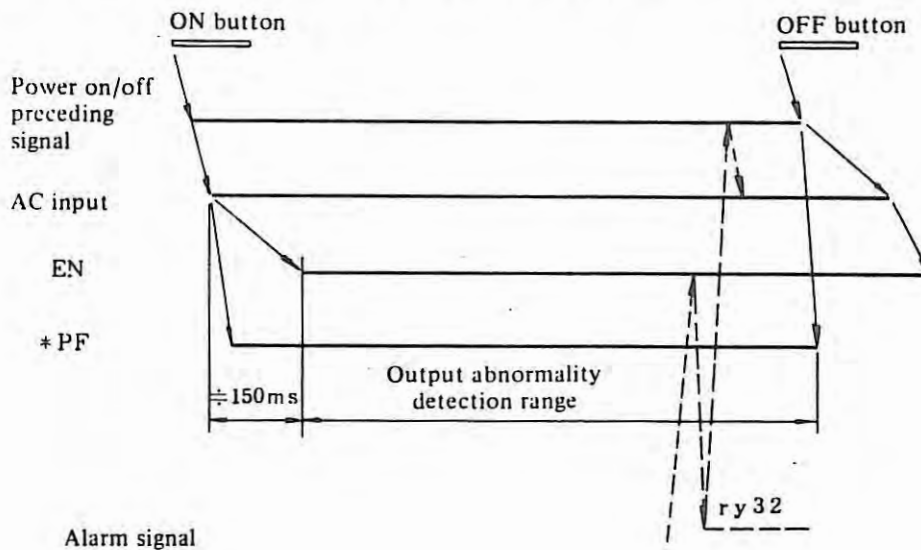

When EN signal becomes LOW level or receiving an external alarm signal.

2. Check Points

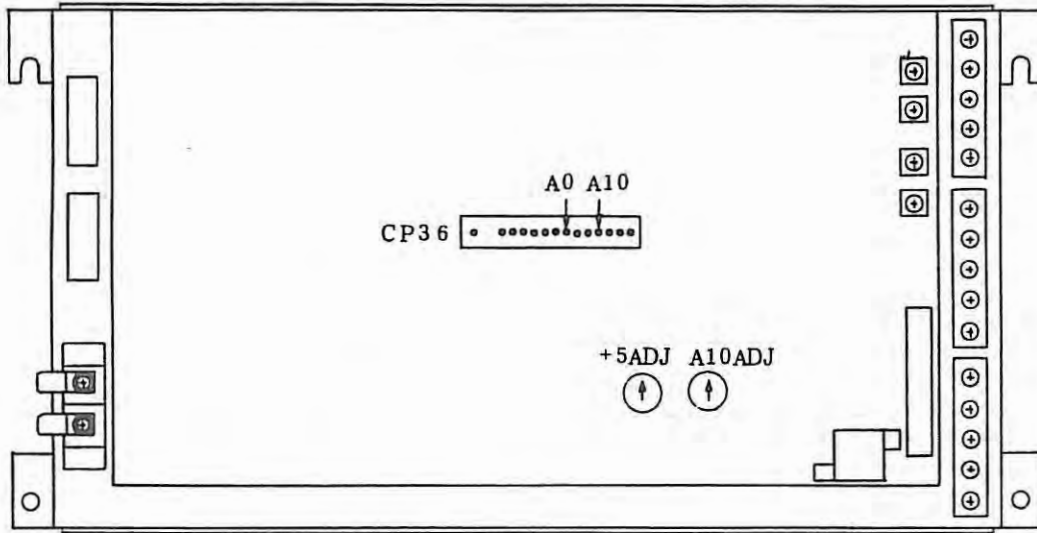

(1) Adjustment of nominal voltage

Measure the voltage between A10 and A0 in the connector CP36 with a digital voltmeter and confirm that it is 10.00V. When it is out of 10.00V, adjust it with the variable resistor A10ADJ. The voltage increases by rotating A10ADJ in the clockwise direction (↻).

(2) Adjustment of +5V output voltage

The +5V output voltage is adjusted by the variable resistor +5ADJ. The voltage increases by rotating +5ADJ in the clockwise direction (↻).

3. Voltage Monitor Circuit

Each output voltage and auxiliary power supply voltages are always monitored. If an abnormality is detected, the EN signal turns off, an alarm signal is issued to the input unit and the power is turned off.

Abnormality detection level and major causes of abnormality occurrence in the voltage monitor circuit are explained in the table 3.1.

Each voltage monitor circuit has a short-circuit plug S1 ~ S7, which determine the abnormality detection effective or not. Normally all plugs S1 to S7 are inserted (All are effective). If any of plugs S1 to S7 are removed, the corresponding voltage monitor circuits become ineffective.

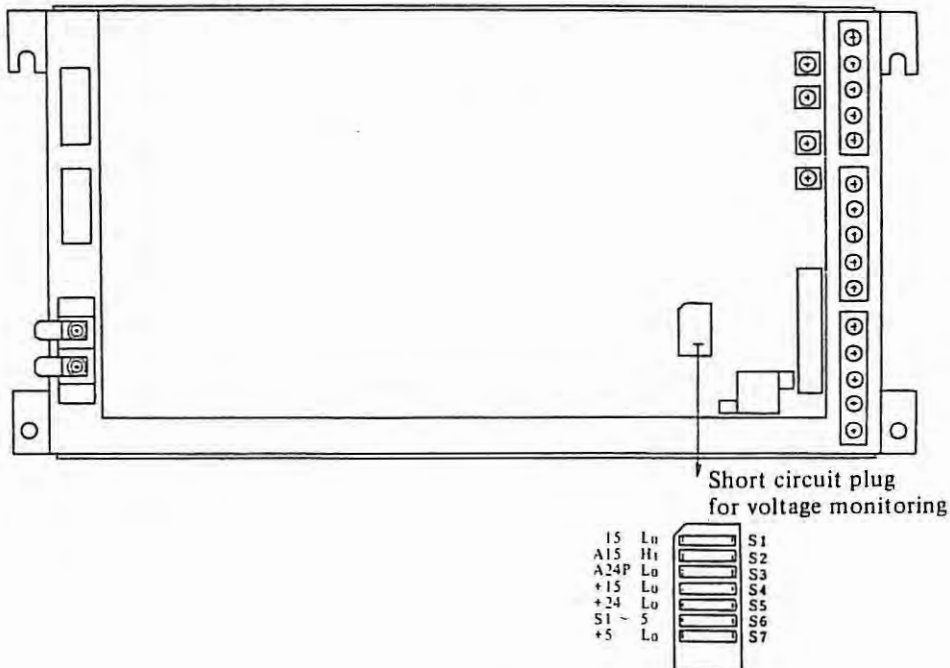

Table 3.1

Voltage monitor circuit and abnormality detection level (Absolute value)		Major causes of abnormality				Symbols of the shorting plugs	
		Actuation of OVP and OCL	Rectifier and control	Primary circuit	External conditions		
+5V	Less than 97%	+5V circuit OVP actuation +5V circuit OCL actuation Primary circuit OCL actuation	Switching stop due to A15 voltage drop Trouble of D11 ~ D12 Trouble of +5V control circuit	Trouble of power switch circuit Blow out of AF11 ~ AF12	Input AC voltage drop	S7	
+24V	Less than 19.2 to 20.5V	+24V circuit OVP actuation +24V circuit OCL actuation Primary circuit OCL actuation	Switching stop due to A15 voltage drop Trouble of DS12 Trouble of +5V and +24V control circuit			S5	S6 (= S1 ~ S5)
+15V	Less than 12.9 to 13.7V	+15V and +24V circuits OVP actuation +15V and +24V circuits OCL actuation	Trouble of RG33 Trouble of D45 and D46	S4			
-15V	Less than -11.6 ~ -13.5V	-15V circuit OVP actuation -15V circuit OCL actuation	Trouble of RG32 Trouble of D33 and D34 Trouble of DS31	S1			
A24P (Auxiliary power supply)	Less than 16.5 ~ 17.5V	—	Trouble of DS31	S3			
A15 (Auxiliary power supply)	More than 16.8 ~ 17.8V	—	Trouble of RG31 Trouble of D31	S2			

OVP: Over voltage protecting function
OCL: Over current limiting function

Removing of S6 is equivalent to removing all S1 to S5.

4. OVP and OCL functions

Each circuit is provided with the OVP and OCL functions, which operate at levels as in the table. When the OVP operates, the output terminal thyristor turns on, the output shorts and the over voltage is absorbed. When the OCL operates, the output voltage drops according to the degree of over current. So both OVP and OCL become error causes in voltage monitor circuits.

	OVP operating level (Absolute value)	OCL operating level
+5V	6.0 ~ 6.5V	28 ~ 30A
+24V	29 ~ 34V	5 ~ 6A
+15V	16 ~ 19V	Approx 1.5A
-15V	16 ~ 19V	Approx 2A
Primary circuit	—	5.4 ~ 5.7A

5. LEDs (LD31, LD32)

The printed circuit board contains two light emitting diodes of LD31 and LD32.

LD31 lights while OCL function of primary circuit is operating. LD32 lights when the alarm signal output is issued to the input unit.

LD31 may light temporarily when turning on power owing to the actuation current.

When LD32 lights on, AL Relay operate and ALM lights on.

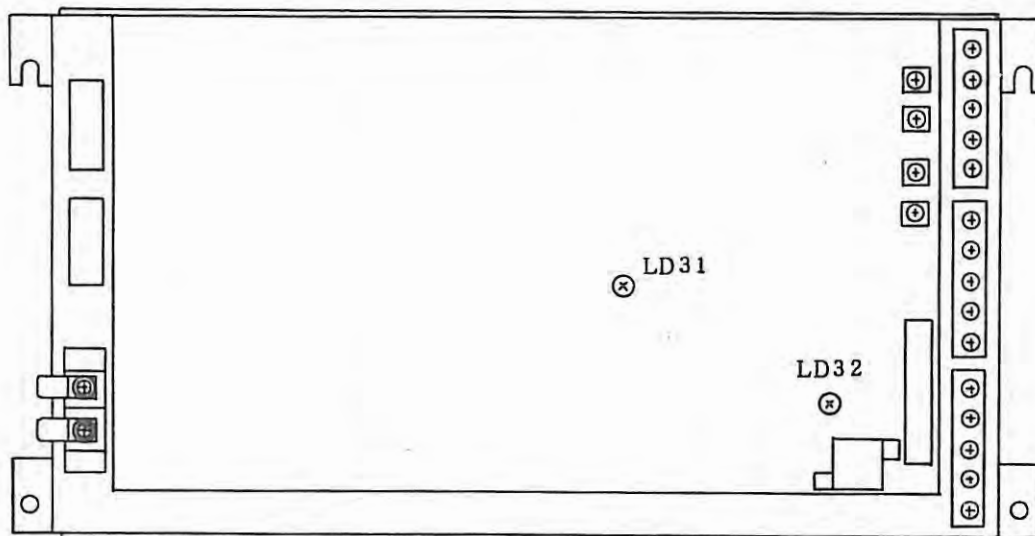

6. Replacing the Printed Circuit Board

- (1) Turn off the power and remove the cover  which is fixed with four plus screws.
- (2) Remove the connections at the connector CP31 ~ 35.
Also, when there are the cables connected at the terminals +15S, -15S, ALA, ALB, etc, remove them.
- (3) Remove the printed circuit board (A20B-0007-0330) which is fixed with four bolts and two screws and mount the new one.

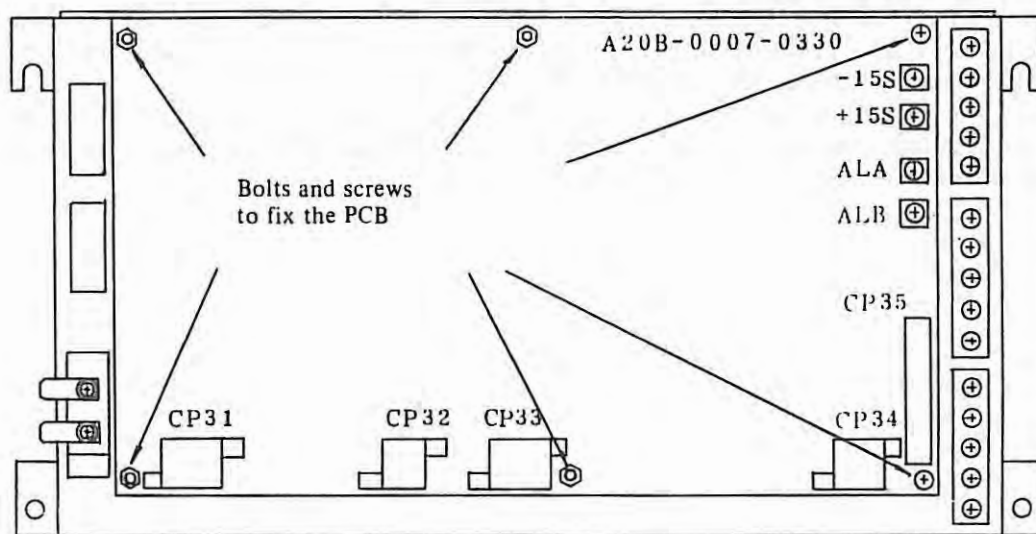
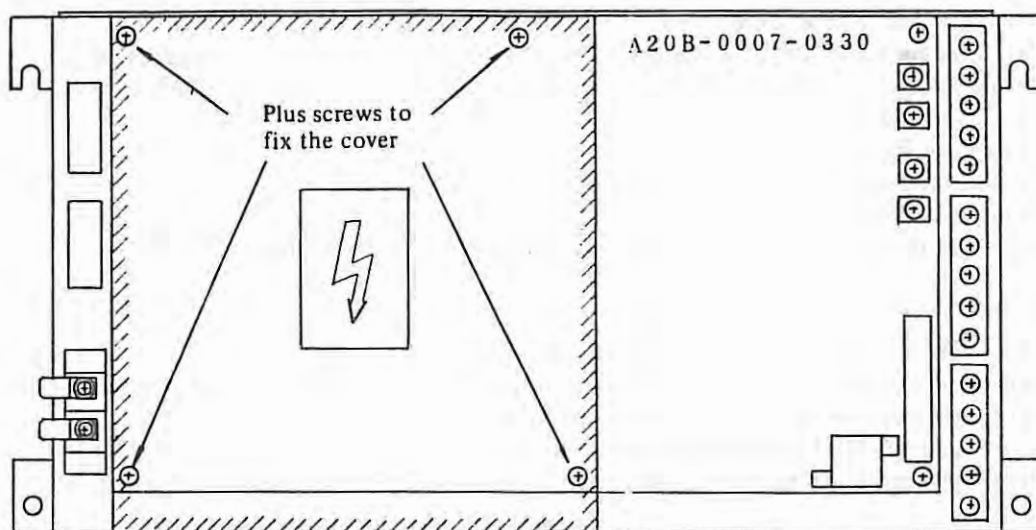

- (4) Connect the connectors CP31 ~ 35.
Connect the cables to the terminals +15S, -15S, ALT and ALB, if these cables exist.
- (5) Turn on the power and confirm the following items.
 - ① Measure the voltage between A10 and A0 at the checking terminal CP36 with a digital voltmeter. And confirm that it is 10.00V. If it is not 10.00V, adjust it with a variable resistor A10ADJ.
 - ② Measure the +5V output voltage. If it is not +5V, adjust it with a variable resistor +5ADJ. (When the measuring point and adjusting value for +5V are regurated, conform them.)
 - ③ Measure the followings:
 - +24V output voltage
 - +15V output voltage
 - 15V output voltage
 Confirm that they are within the allowable range.
- (6) Turn off the power and mount the cover.

7. Causes of fuse blowout and trouble-shooting

The power stabilizer unit contains fuses F11 and F12 at the input terminal.
The trouble-shooting when these fuses blow out is mentioned in the followings:
The following items are considered the causes of blown out of these fuses.

- (1) Short-circuit of surge absorber VS11
VS11 is mounted behind the F11 and F12 and is used to absorb the surge voltage between the input lines. When a large surge voltage is applied or when an excessive voltage is applied constantly, VS11 shorts and F11 and 12 are blown out.
- (2) Diode stack DS11 shorts
- (3) Switching transistors Q49 and 50 short between C and E.
- (4) Diodes D71 and D72 short.
- (5) Contact of the wiring and/or parts of the primary circuit with the cabinet.

Trouble shooting

- (1) Remove the cover and PCB referring to the items 6-(1) ~ (3).
- (2) Disconnect the DS11 faston terminal. Thus because VS11 and DS11 are separated from other circuit, check them for continuity with a tester whether they short or not.
- (3) If VS11 and DS11 are normal, check Q49 ~ 50 and D71 ~ 72 in the printed circuit board.
- (4) Check the continuity between primary circuit and frame to check whether they short when there are no faulty parts.
- (5) After replacing faulty circuit parts, if any, and correcting contacts with cabinet, restore all the connections removed for checking.
- (6) Turn on the power after replacing fuses to check whether the causes of fuse blown out have been removed. Because F11 and F12 are UL-designated parts, their wires cannot be replaced like general alarm fuses. Their ordering number is A60L-0001-0101#P450H.
- (7) Even when VS11 shorts and you don't have spare, operation can be started without VS11, but you must get a spare as fast as possible (Specially, under the condition where the surge voltage is generated frequently.) The ordering number of VS11 is A50L-8001-0067#391.

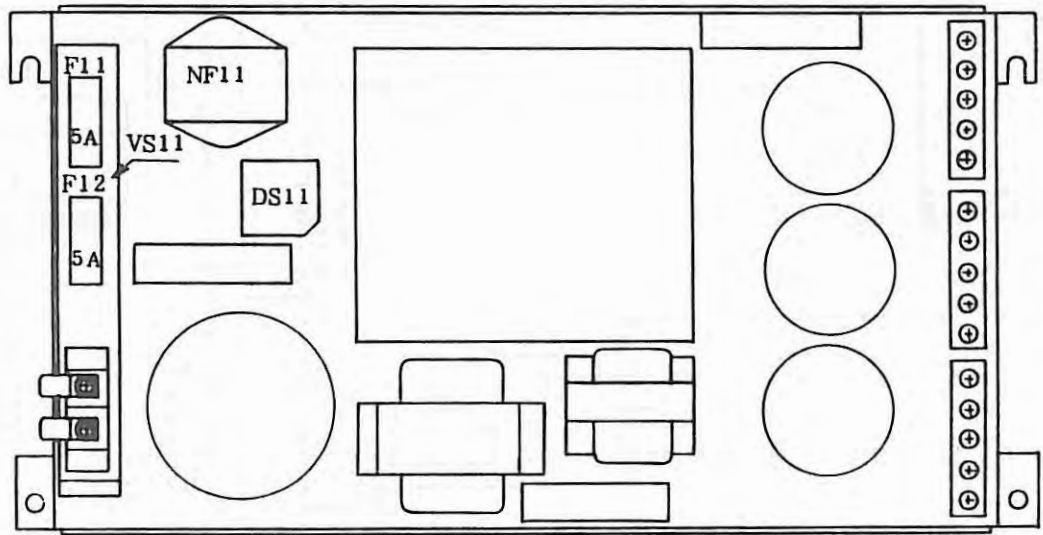
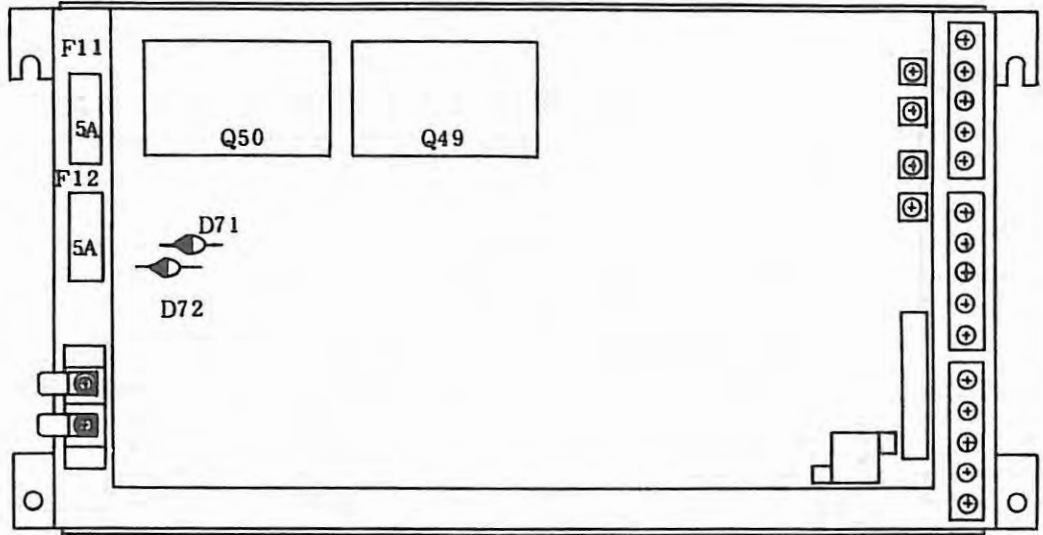

With PCB unit removed

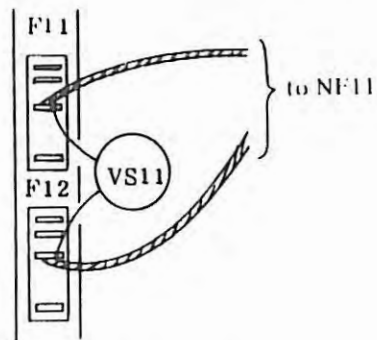

VS11 is mounted behind F11 ~ 12 as shown above.

8. Block Diagram and Time Chart

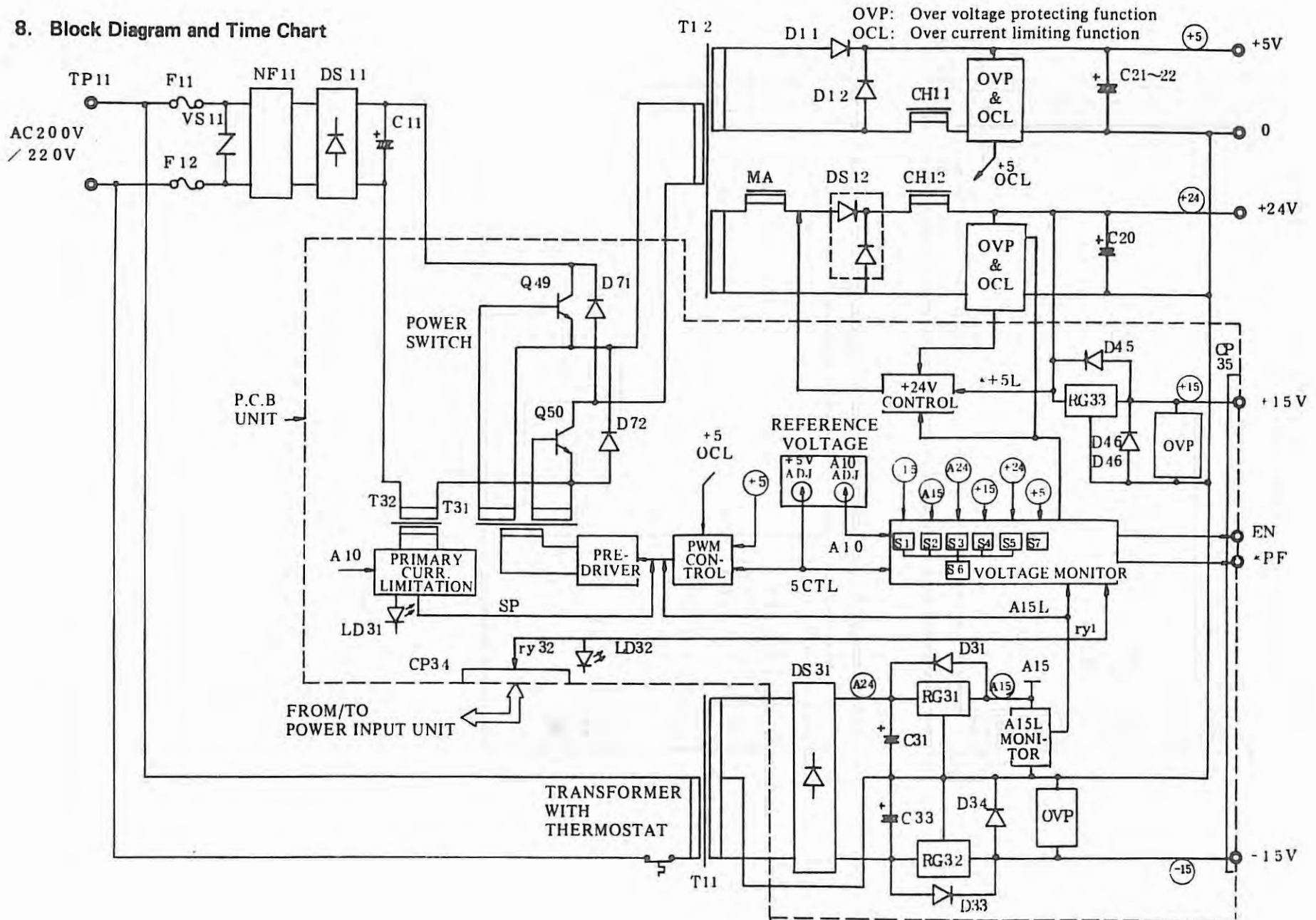

Timing of ON and OFF

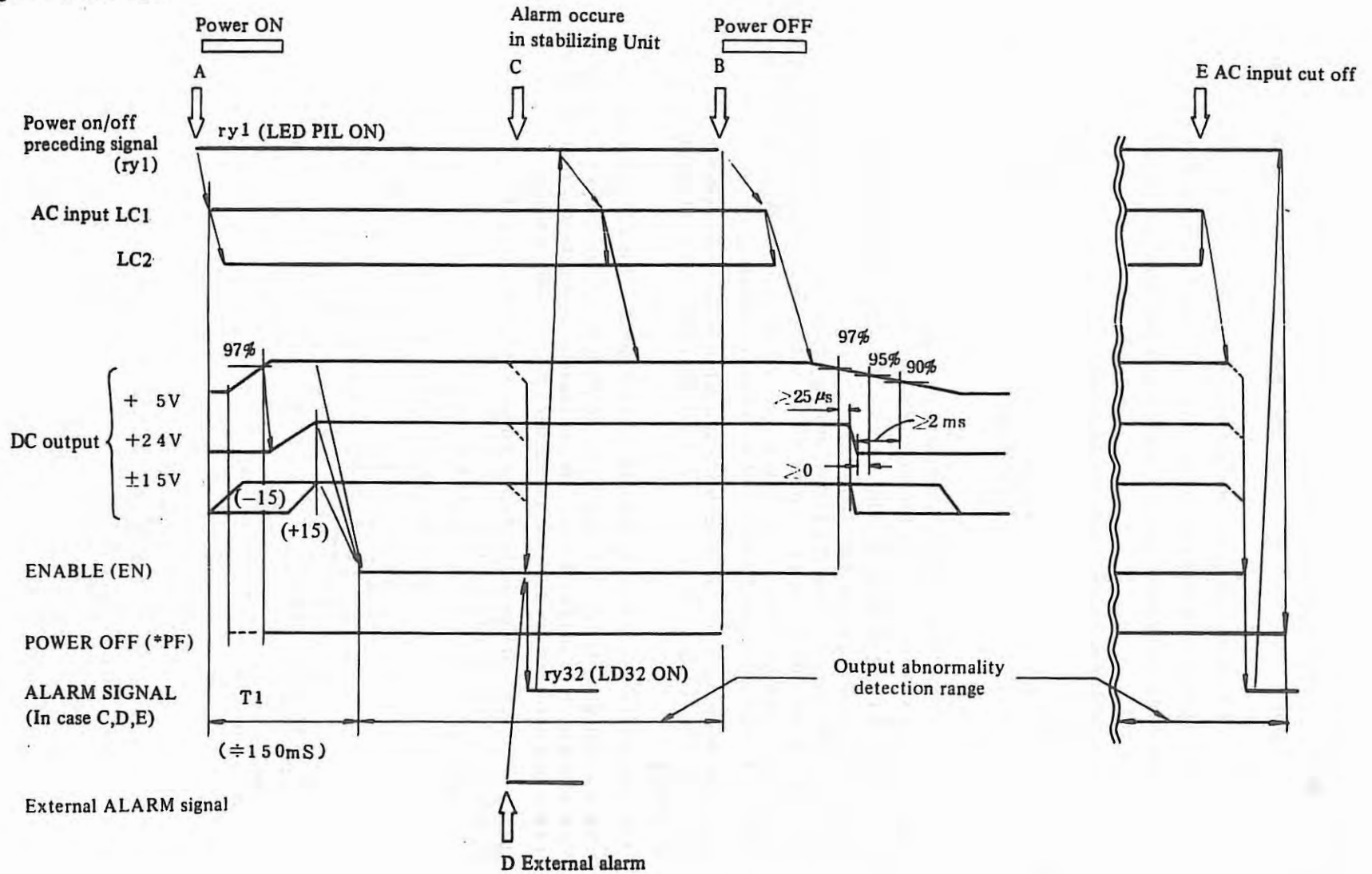

- C: Abnormality generation in the power stabilizer unit
 - D: External alarm generation
 - E: Abnormality detection due to cutting off the AC input
- } Alarm signal issuance (ry 32)

9. Power input unit

(1) There are following four kinds of power input units.

They are classified into two types of for free standing type cabinet and for built-in and unbundled type cabinets.

- 1 A14B-0061-B101 (Free standing type and built-in type 2, servo fuse: less than 30A, domestic use)
- 2 A14B-0061-B102 (Free standing type and built-in type 2, servo fuse: less than 30A, export use)
- 3 A14B-0061-B104 (Free standing type and built-in type 2, servo fuse: less than 40A, for both domestic and export uses.)
- 4 A14B-0061-B103 (Built-in type 1 and unbundled type)

Fig. 9.1 shows the connection diagram on power supply for the free standing cabinet and built-in type 2 cabinet. Fig. 9.2 shows the connection diagram on power supply for the built-in type 1 and unbundled type cabinets. The export use input for free standing type cabinet is provided with a MULTI-TAP TRANSFORMER.

(2) The PCB (A20B-0007-0340) in the power input unit is common for all input units.

The maintenance procedure on this PCB is mentioned below.

- ① Two LEDs of PIL and ALM are provided with this PCB. PIL (Green LED) lights while the power is supplied to the power input terminal board TP1.
ALM (Red LED) lights when this PCB receives an alarm signal from the power stabilizer unit. When ALM lights, NC line contactors LC1 and LC2 turn OFF. NC power cannot be turned on under this condition. To reset this condition power supply must be once cut off or the POWER OFF button (Either NC POWER OFF button or external POWER OFF button) must be pushed.
- ② Even when NC power is off, the power has been supplied to the circuit before the line contactors LC1 (and LC2) while PL1 lights. When you touch some units inside the power input unit, confirm that PIL is not lighting.
- ③ Check the voltage for relays in the PCB unit between (0) and (E). 21 to 22V is normal.
- ④ When it is desired not to cut off the power with an alarm at trouble-shooting by ALM lighting, connect check pins between P1 and P2. However, the time taken for trouble-shooting must be as short as possible and you must disconnect the check pins immediately after the trouble shooting.
- ⑤ The fuse F3 (0.32A) will blow out by short-circuiting of parts within the PCB.
Replace the fuse after trouble-shooting.
The ordering number of F3 is A60L-0001-0046#0.32.

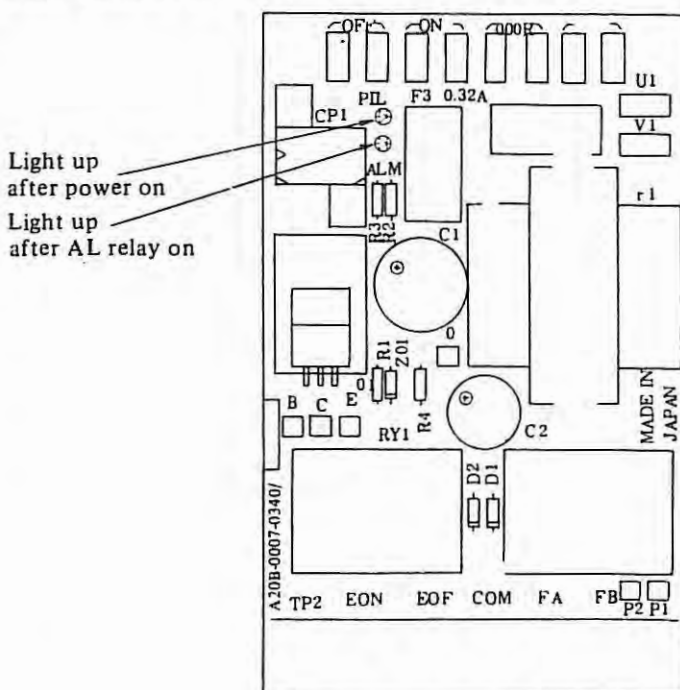

Power input unit PCB (A20B-0007-0340)

A20B-0007-0330

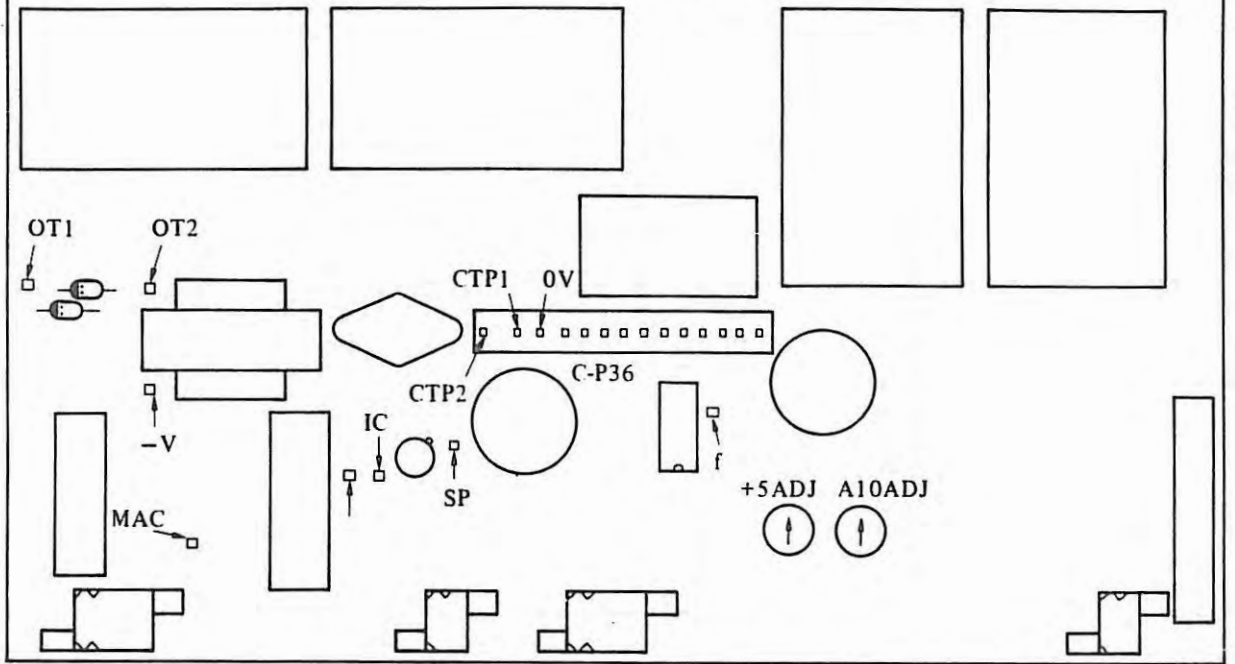

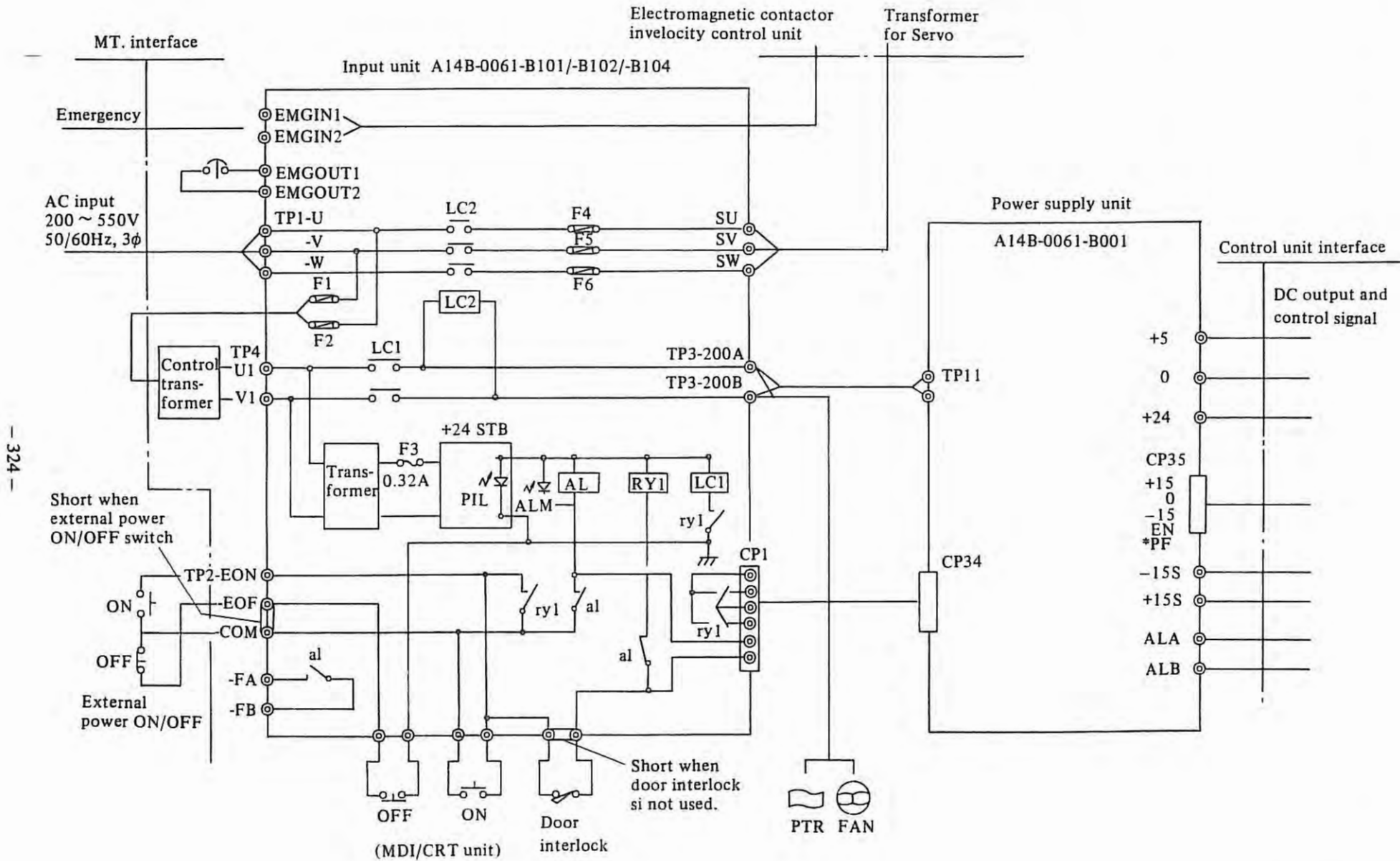

Fig. 1 Connection Diagram on Power Supply (For self-standing type cabinet and built-in type 2 cabinet)

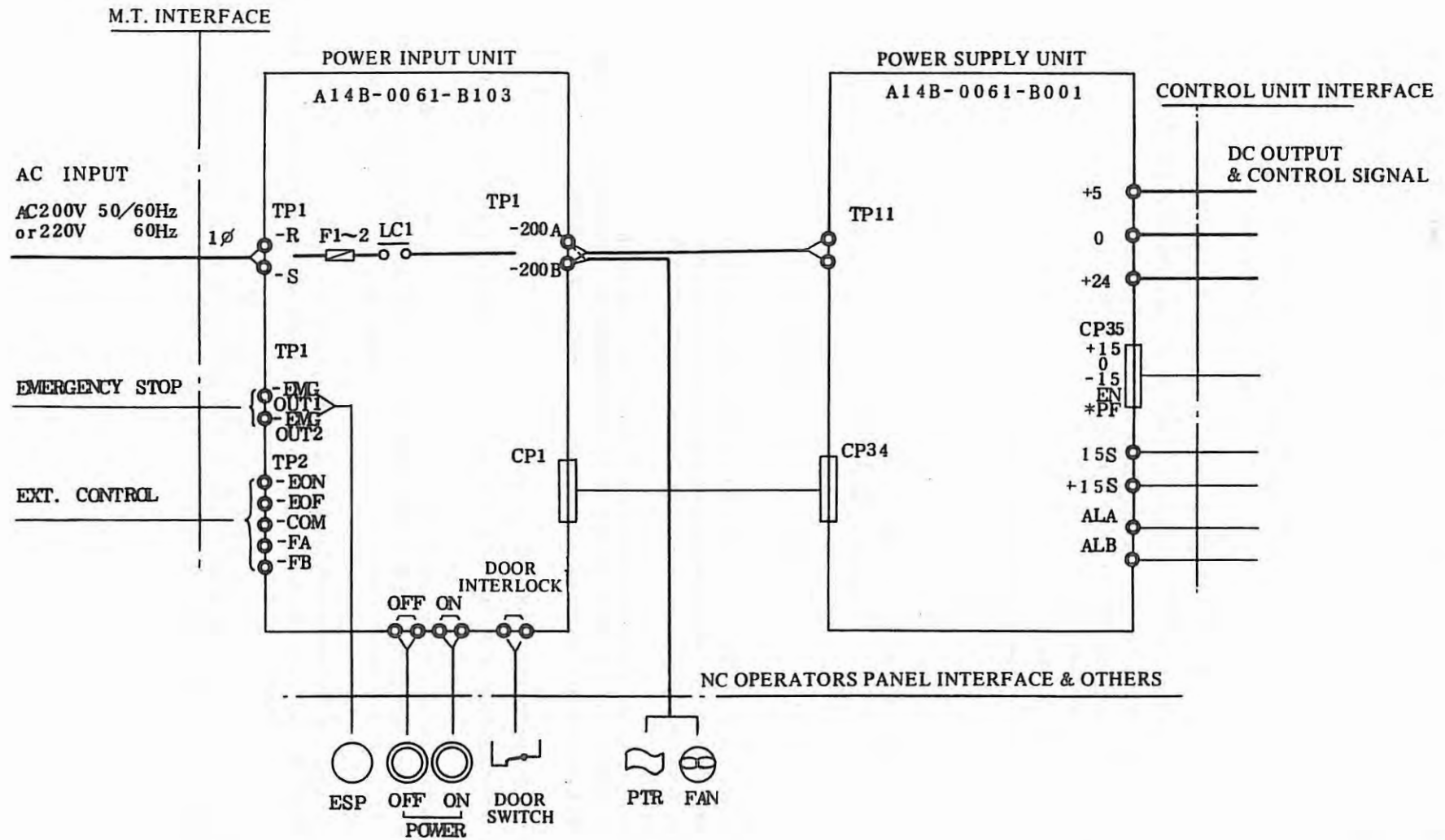
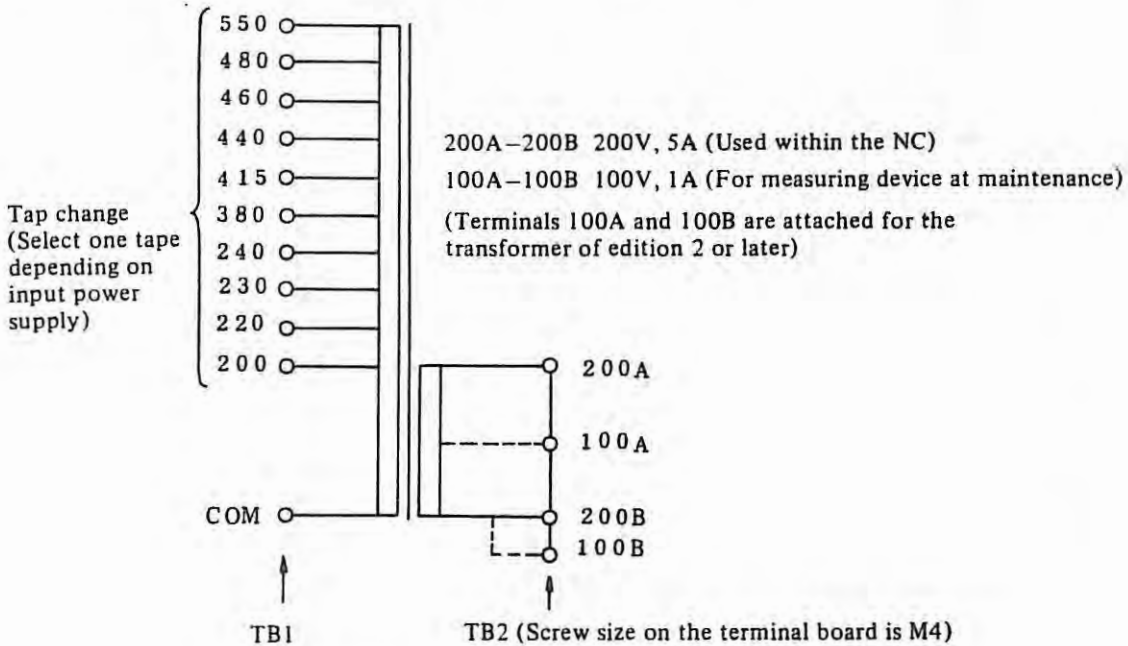

Fig. 2 Connection Diagram on Power Supply (Built-in type 1 cabinet and Unbundled type cabinet)

10. Control Unit Power Transformer

A control unit power transformer (A80L-0001-0176) is required when the input power supply is other than AC 200V, 50Hz, 60Hz and AC 220V, 60Hz.

This transformer has taps for AC 200/220/230/240/380/415/440/460/480/550V on the primary side (MULTI-TAP TRANSFORMER). Select one tap depending on input power voltage.



An output between 100A and 100B is used only for measuring device at maintenance. This output must not be used for a long time. Also, because this output does not have any protective means such as fuses, even when used for measuring device, you must carefully examine whether the measuring device has the short-circuit or whether the load current does not exceed 1A.

Moreover, when you touch on the terminals such as TB1, TB2, etc, you should touch after turning off the main switch of the magnetics cabinet. (You can confirm the main switch ON and OFF by the PIL lamp in the power input unit. PIL lights while the main switch is ON, but extinguishes while that is OFF.)

11. Waveforms under operations of each unit

The standard waveforms under operations of each unit in the power supply circuits are mentioned in the followings.

Notes: 1. These waveforms are used to check whether the power supply circuits are operating normally or not.

2. Checking of these waveforms must be performed by a person who attended a maintenance course of FANUC NC school or who have been participating in the maintenance of the electric devices for more than 2 years.

3. When checking waveforms, the oscilloscope must be floated from the grounding.

4. Never observe the primary and secondary signal waveforms simultaneously in a two channels oscilloscope because the primary side signal is floated from the grounding.

If observed simultaneously, the power supply circuit may be damaged.

5. When observing the primary side signal, because the high voltage is applied to the parts and the oscilloscope is influenced by high voltages, be careful not to touch on parts and oscilloscope.

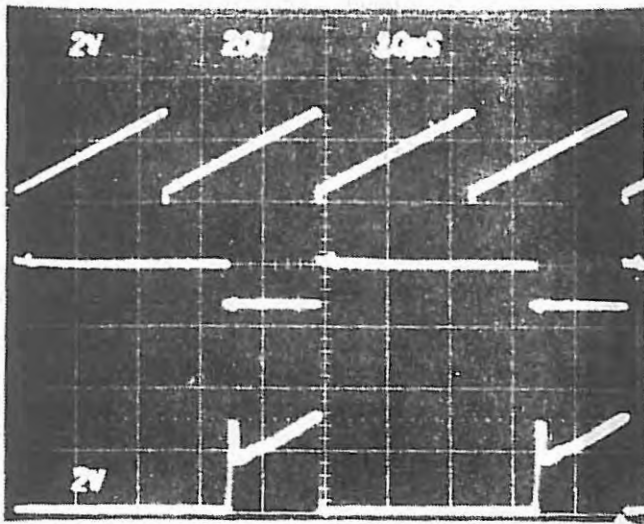

Input: 200V 50Hz
 Load: Rated load +5, 23A
 +24, 4A
 +15, 0.7A
 -15, 0.7A

f (2V/div)

--0V

CTP1 (2V/div)

Time scale: 10µs/div

--0V

CTP2 (20V/div)

--0V

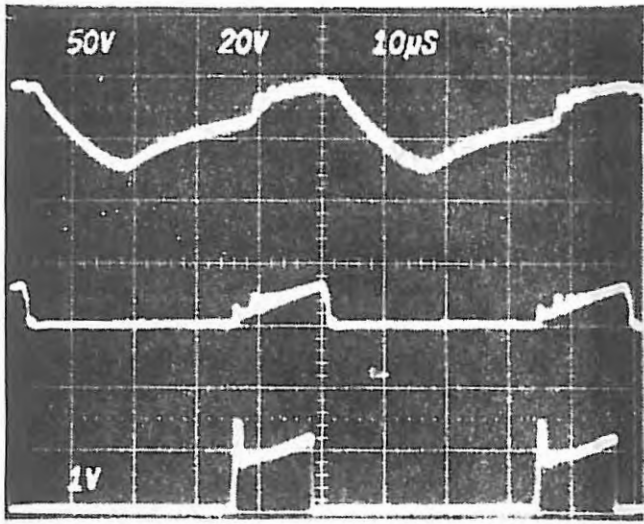

--0V

MAC (50V/div)

IC (1V/div)

--0V

CTP2 (20V/div)

--0V

Primary circuit current limit operates for the voltage more than approx. 1.8V.

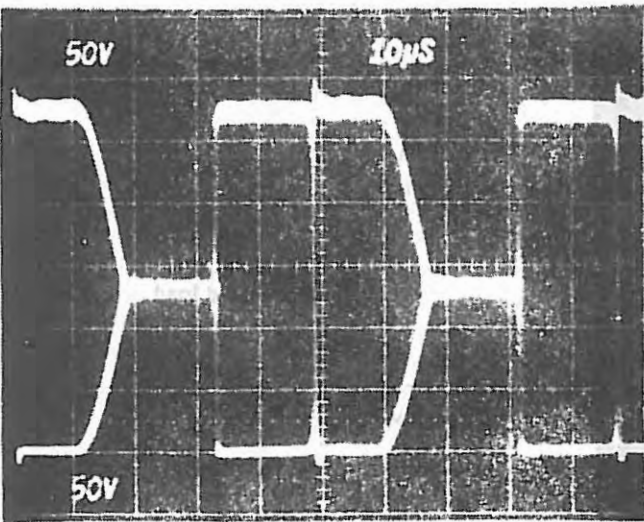

OT1 - (-V)
 (50V/div)

OT2 - (-V)
 (50V/div)

--0V

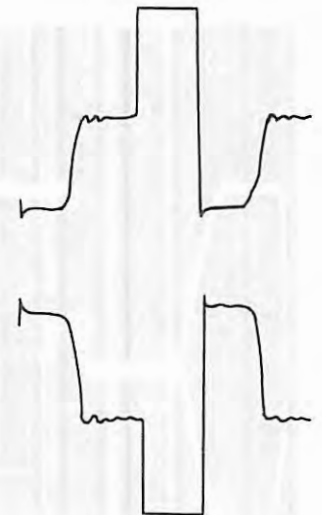

T = 45 ~ 50µs

Input: 200V, 50Hz
 Load: Light board +5, 10A
 +24, 1A
 +15, 0.1A
 -15, 0.1A

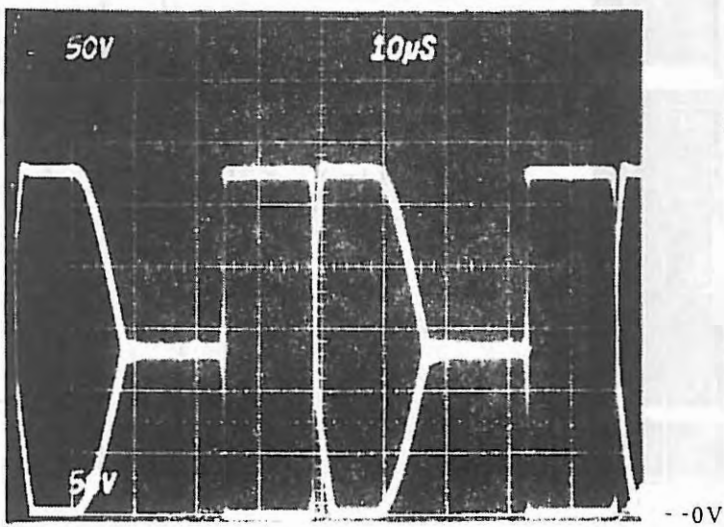
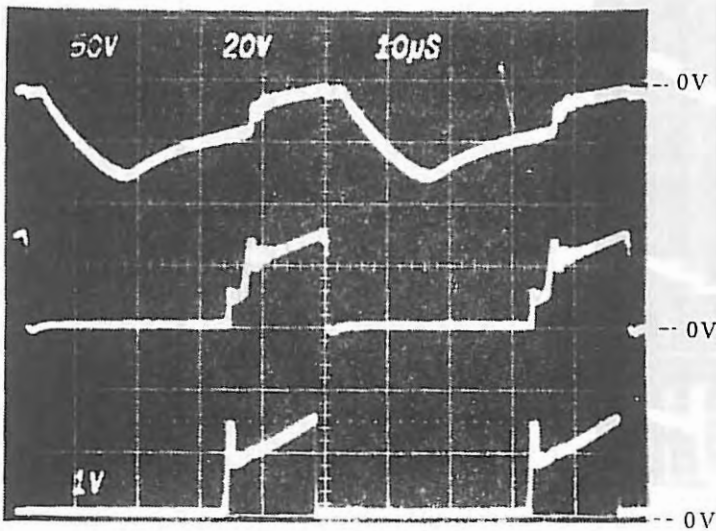
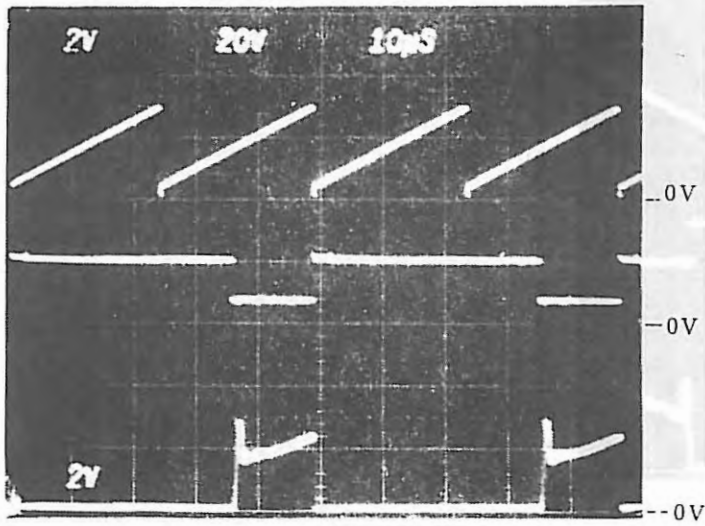

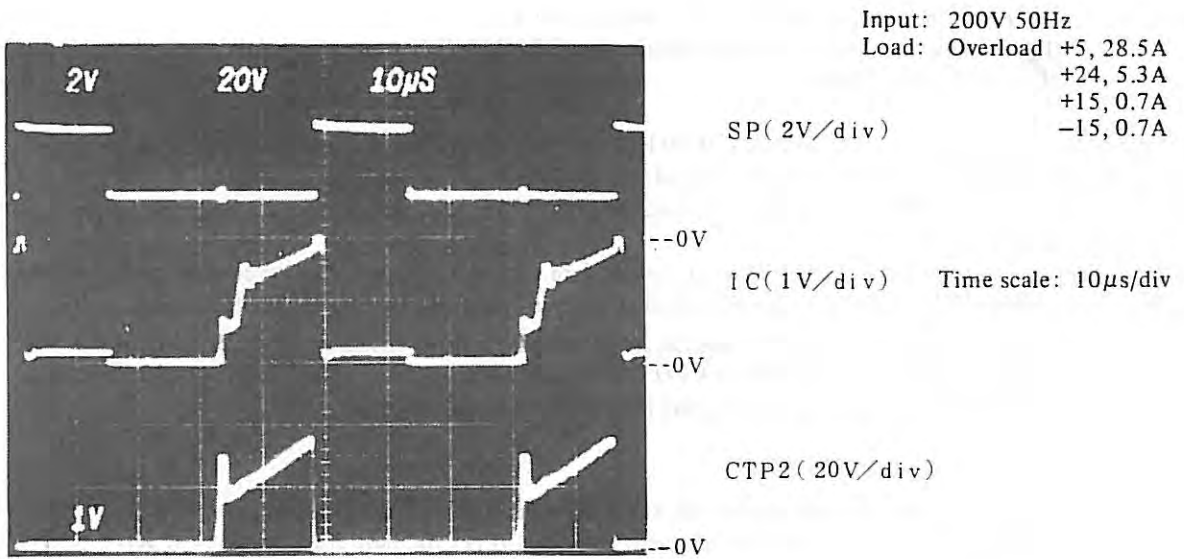

The waveform above shows that when the primary circuit current limitation is operating because of the overload of +5 and +24.

The part of the IC waveform indicated by the sign (↔) in the figure below is generated due to the current which flows from R99 to D56 to R98 and to 97 because of output of M32 becoming High level.

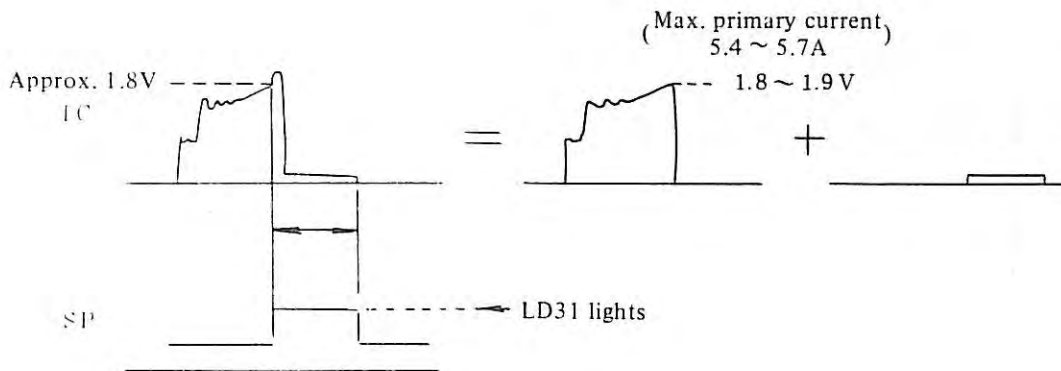

Appendix 4 Adjustment method of velocity control unit (Individual Adjustment Applicable for FANUC DC motor models 0, 5, 10, 20, 30, 10H, 20H and 30H)

Set the power frequency selector switch (50/60 Hz) on the velocity control unit PCB to the input power frequency at installing the NC unit. The velocity control unit becomes ready to operate after this.

The velocity control unit PCB can be applied to some different kinds of motor models by changing strap lines and by adjusting variable resistors.

If the machine does not operate normally with the standard setting, adjust the velocity control unit by setting the variable resistor on the PCB referring to the individual adjustment which is described in the followings.

(Note) The velocity control unit for high inertia series motor (6-phase thyristor drive) is described in this section. Please refer to FANUC DC SERVO UNIT maintenance manual (B-53265E) about maintenance of velocity control unit midium inertia series motor (PWM transistor drive).

Individual Setting

General machine tools operate normally by the standard setting. But if the machine tool does not operate normally by the standard setting, the individual setting is required to get the best characteristics of servo system depending on the characteristics of the machine tool.

1. Method

Adjust the variable resistors on the velocity control unit PCB observing the motor current which is measured on the both ends of motor current detect resistor.

Refer to the followings for detail.

Notes 1 Generally an adjustment for the part of the servo system tends to reduce the performance of the other part of the servo system. So the adjustment should be done taking this into consideration.

2 The motor current can also be observed at CH11. The output voltage at CH11 is 3.3 times that of detect resistor voltage. The waveforms include some noises (short pulses) but they are not abnormal.

3 All waveform in this section is shown on 50Hz.

Stopped stage 1

Figures 1, 2 and 3 can be observed with units for models 0, 5, 10, 20 and 30. In contrast, Figures 4 and 5 can be observed with units for models 0_L and 5_L (with choke).

Usable waveform

Model waveform

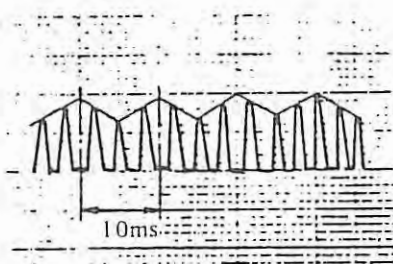

Fig. 1

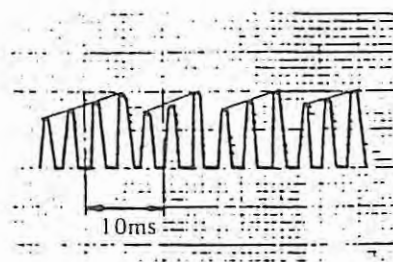

Fig. 2

Adjustment 1

Adjustment 2

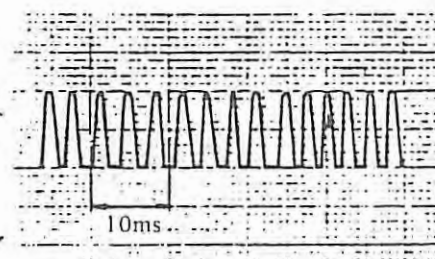

Fig. 3

Usable waveform

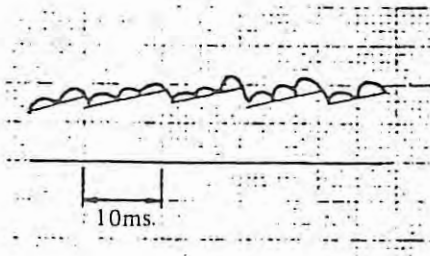

Fig. 4

Model waveform

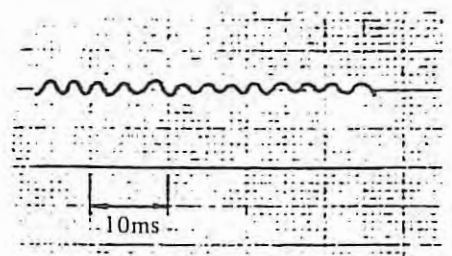

Fig. 5

Adjustment 3

In case of standard setting, the waveforms shown in Figures 1, 2 and 4 usually appear. This is because the distortion of waveform and variation on phase difference exist in the input power supply.

In most machines the variation of waveform in such a degree does not effect the abnormal operation of machine tool. So, the arrangements to Figure 3 are not necessarily required.

However, because even such a degree of variation will cause the vibration or noise on some machine tools, waveforms can be amended toward figure 3 in the following manner.

Adjustment 1, 2, 3

RV10A ~ C shall be rotated by half scale to a scale so that the peaks of waveforms may be unified.

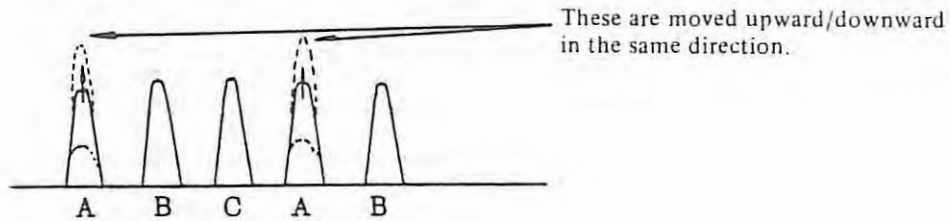

RV11A ~ C shall be rotated by half scale to a scale so that peaks of waveforms may be unified.

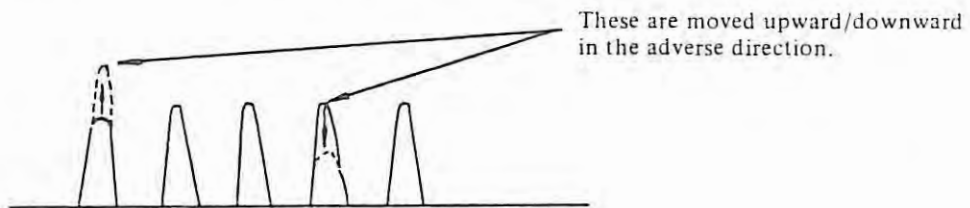

Stopped stage 2

These are the waveforms of axes on which load torque is little.

Usabel waveforms

Unusable waveforms

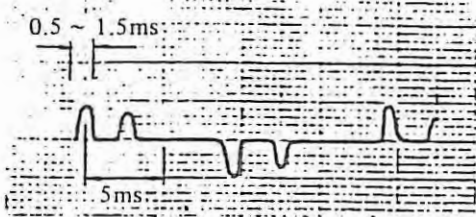

Fig. 6

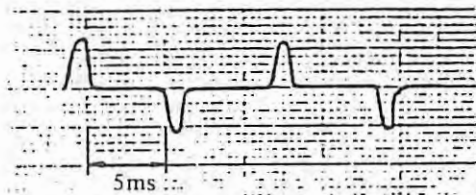

Fig. 7

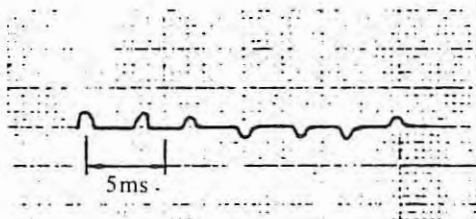

Fig. 8

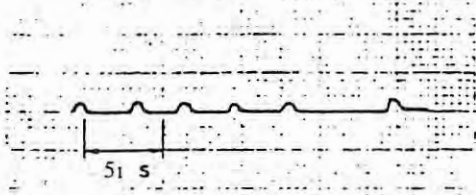

Fig. 9

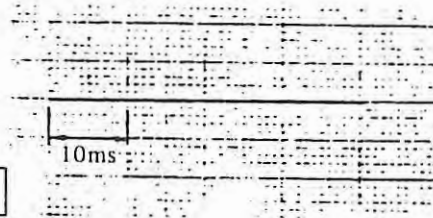

Fig. 10

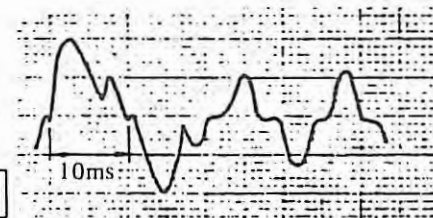

Fig. 11

Adjustment 4

Adjustment 4

This is because of too small dither. So, RV3 shall be rotated clockwise by half scale to one scale. When adequate waveform does not appear in spite of such operation, the following points may be considered.

- (1) Phase rotation of input power supply is faulty.
- (2) "SERVO OFF" is effective.

Note: Adjustment 4 shall be made so that waveforms shown in Figures 6 to 9 may appear.

Adjustment 5

Adjustment 5

This is because of too large dither. It is caused from erroneous setting of 50/60Hz switch. It will be amended if RV3 is rotated counterclockwise. If adequate waveform does not appear in spite of such operation, the following points may be considered.

- (1) Oscillation is generated because setting of RV1 is too large.
- (2) Erroneous setting of S1 ~ 9.
- (3) Erroneous connections between NC and Motor.

Note: Adjustment 5 shall be made so that waveforms shown in Figures 6 to 9 may appear.

Stopped stage 3

These are the waveforms which appear when trouble happens.

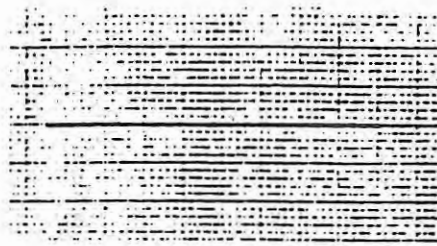

Fig. 12 Unusable waveform

Research 1

- 1) Phase rotation of input power supply is incorrect.
- 2) Servo off is highered.
(Enable is not highered in the velocity control unit)
- 3) Waveforms in printed circuit board shall be checked individually.

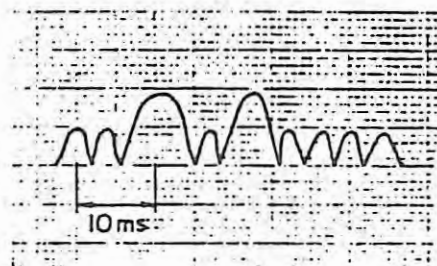

Fig. 13 Unusable waveform

Research 2

- 1) Phase rotation of input power supply is incorrect.
- 2) This phenomenon happens also when gain is highered excessively. So, RV1 shall be rotated counterclockwise a little.
- 3) When load is larged and current limiter is applied, this phenomenon may happen because gain of current limiter is highered excessively. So RV8 shall be rotated counterclockwise by approximately one scale.
- 4) Waveforms in printed circuit board shall be checked individually.

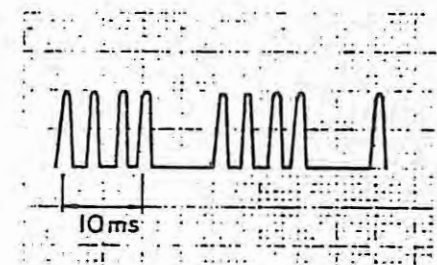

Fig. 14 Unusable waveform

Research 3

- 1) Firing pulse is not applied to the gate of one thyristor among 7 thyristors.

Note: When load torque on the machine is little, waveform shown in Figure 14 may appear. If waveforms are unified every 3.3 m sec. when rotation is made with low speed, the system is normal.

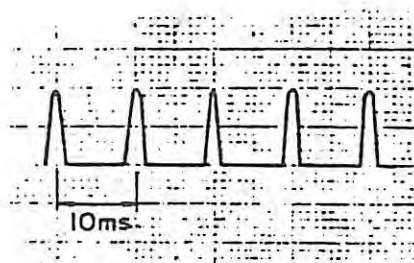

Fig. 15 Unusable waveform

Research 4

- 1) One phase among 3 phases of input power supply does not exist.
- 2) One of main fuses in velocity control unit is blown.

Note: When load torque on the machine is little, waveform shown in Figure 15 may appear. If waveforms are unified every 3.3 m sec. when rotation is made with low speed, the system is normal.

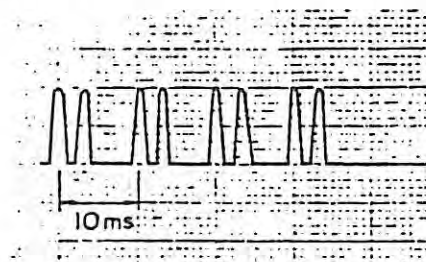

Fig. 16 Unusable waveform

Research 5

- 1) When obstacle occurs on 1 phase among 3-phase control circuits in the printed circuit board, the waveform shown in Figure 16 appears.

During travel

These are observed when a constant revolution is made in the unit for MODELS 10, 20, 30, 10H, 20H and 30H.

Usable waveform

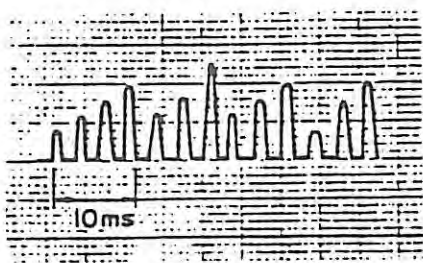

Fig. 17

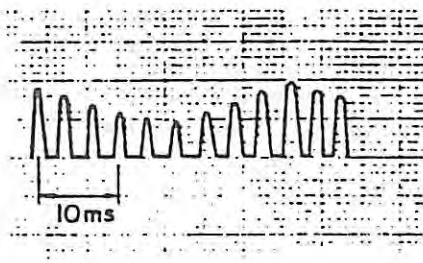

Fig. 18

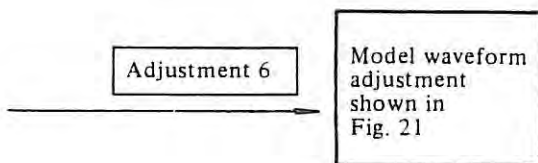



Fig. 19

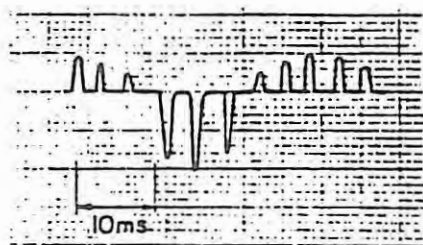

Fig. 20

Note: In adjustment 6, waveforms shown in Figures 17 ~ 20 shall be adjusted to the waveform described in Figure 21.

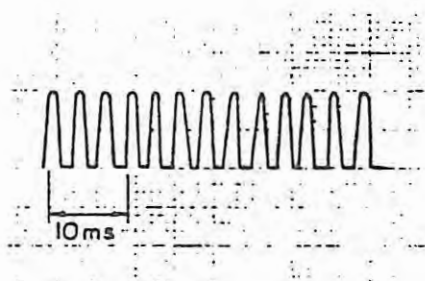

Fig. 21 Model waveform

Adjustment 7



Fig. 22 Unusable waveform

Adjustment 6

Too high gain causes the swell of waveform at about 30Hz. So, RV1 shall be rotated counterclockwise a little.

Adjustment 7

Too low gain causes the swell of waveform at about 5Hz. So, RV1 shall be rotated clockwise a little.

During travel

These are observed when a constant revolution is made in the unit for Model 0L, 5L.

Usable waveform

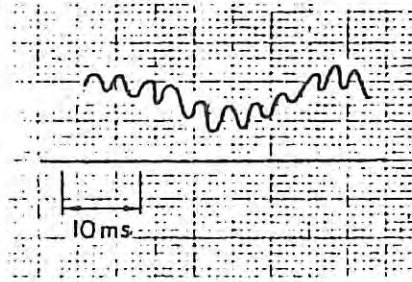

Fig. 23

Adjustment 8

Model waveform

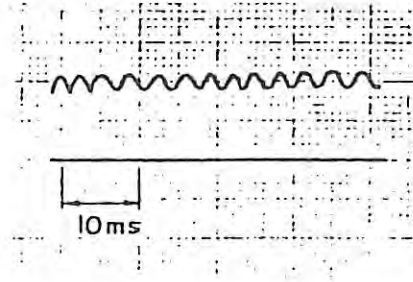

Fig. 24

Adjustment 9

Unusable waveform

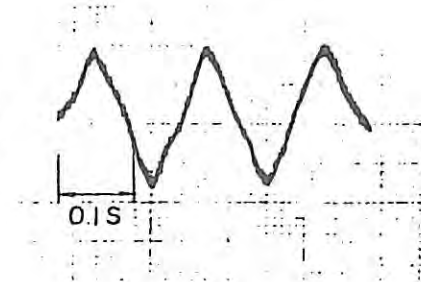

Fig. 25

Adjustment 8

Too high gain causes the swell of waveform at about 30Hz. So, RV1 shall be rotated counterclockwise a little.

Adjustment 9

Too low gain causes the swell of waveform at about 5Hz. So, RV1 shall be rotated clockwise a little.

During acceleration or deceleration

This shows the case when acceleration/deceleration circuit of numerical control is linear. In case of servo with choke in $0_L, 5_L$, the phenomena shown in the following figure appear.

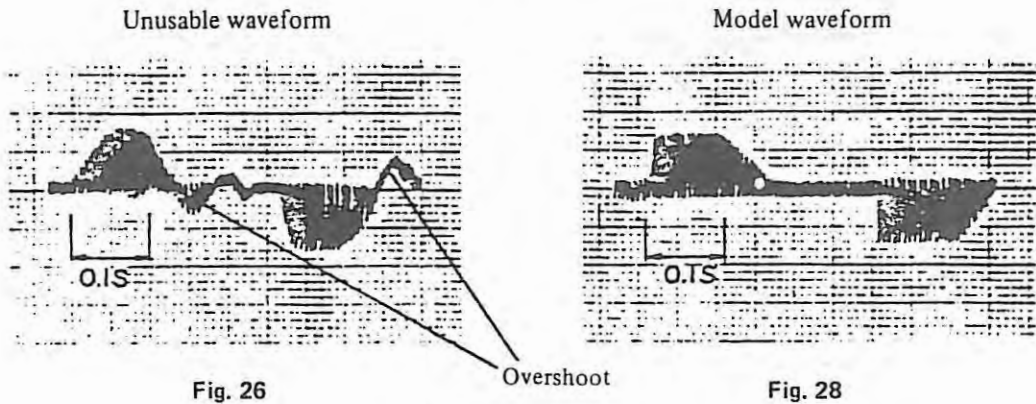

Fig. 26

Fig. 28

Adjustment 10 →

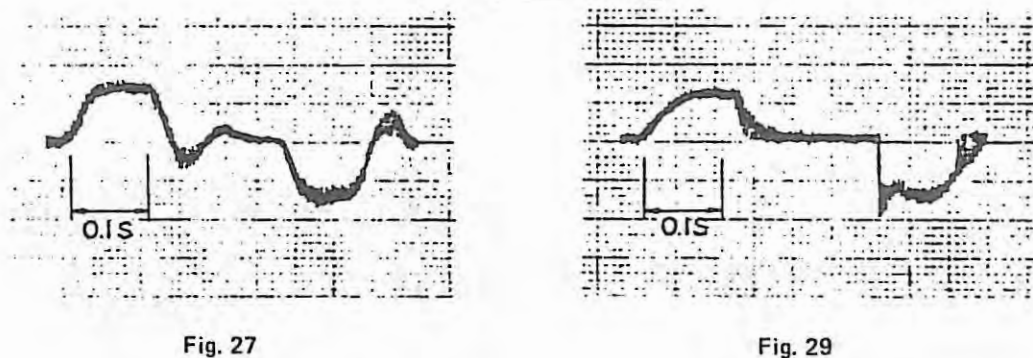

Fig. 27

Fig. 29

(In the case of DC servo motor models 0_L and 5_L)

Adjustment 10

If gain is low, the current waveform overshoots and, the position also overshoots. So, RV1 shall be rotated clockwise a little. If overshooting happens even after RV1 is rotated rightward, position gain shall be lowered to reduce overshooting.

However, if position gain is lowered on 1 axis only, the roundness will be worse when circular cutting is made. So, such gain adjustment shall also be made on the other axis.

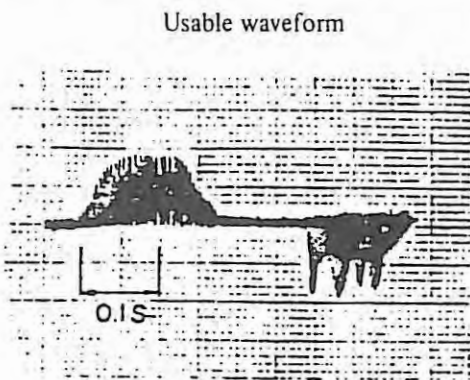

Fig. 30

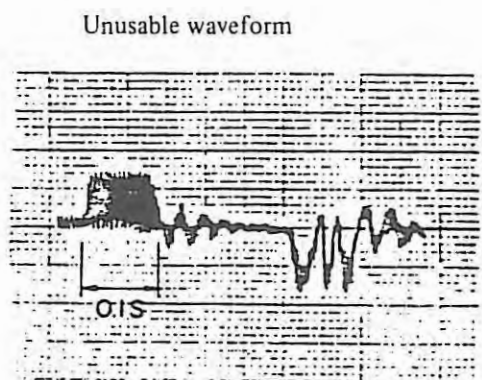

Fig. 32

To model waveform See Figs. 28 and 29 ← Adjustment 11

To model waveform See Figs. 28 and 29 ← Adjustment 12

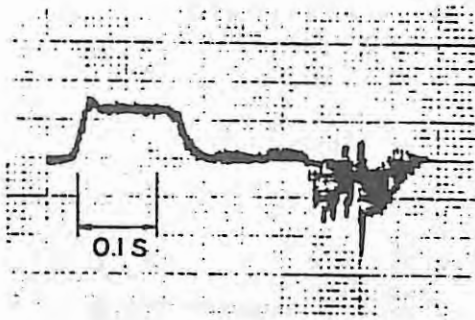

Fig. 31

Adjustment 11

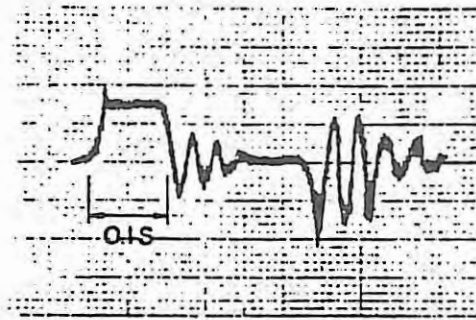

Fig. 33

Adjustment 12



Adjustments 11 and 12

If gain is high, the current waveform will tend to oscillate. So, RV1 shall be rotated counterclockwise a little.

During acceleration/deceleration

When acceleration/deceleration circuit of numerical control is linear.

Model waveform

Unusable waveform



Fig. 34

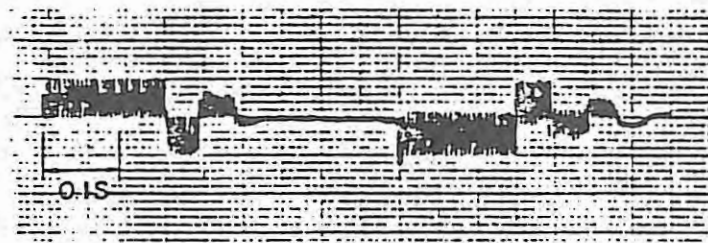

Fig. 36

Adjustment 13

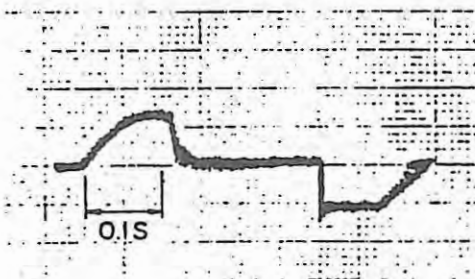

Fig. 35



Fig. 37

Adjustment 13

Current limiter function is incorporated in the velocity control unit. So, overshooting will happen as shown in Figure 36 and 37 if the current is limited lower than the current which is required to accelerate or decelerate. Overshoot of position will also happen.

So, RV9 which limits current shall be rotated clockwise so that the waveform may be similarized as Figures 34 and 35.

Appendix 5 Parts specification of velocity control unit

5.1 For H series servo unit

(1) Velocity control unit for model 0, 5

A06B-6045-H001, 2

With power supply

A06B-6045-H001 (A06B-6045-C001)

Without power supply

A06B-6045-H002 (A06B-6045-C002)

Symbol	Name	Specification	Remark
PCB 1	Printed circuit board	H001; A20B-0007-0360 H002; A20B-0007-0361	
PCB 2	Printed circuit board	A20B-0007-0370	FANUC Spec.
MCC	Magnetic contactor	A58L-0001-0134/15N	FANUC Spec.
MOI	Thermal relay	A58L-0001-0135/14	FANUC Spec.
CDR	Resistor	A40L-0001-0091/20BR050K	0.05 Ω \pm 10% 20W
DBR	Resistor	A40L-0001-0091/20BR330K	0.33 Ω \pm 10% 20W
F4 ~ 6	Fuse	A60L-0001-0118	
TM1, 2	Thyristor module	A50L-5000-0025	FANUC Spec.

(2) Velocity control unit for model 10, 20, 30, 10H

A60B-6045-H005, 6

With power supply

A06B-6045-H005 (A06B-6045-C005)

Without power supply

A06B-6045-H006 (A06B-6045-C006)

Symbol	Name	Specification	Remark
PCB 1	Printed circuit board	H005; A20B-0007-0360 H006; A20B-0007-0361	
PCB 2	Printed circuit board	A20B-0007-0380	
MCC	Magnetic contactor	A58L-0001-0134/20N	FANUC Spec.
MOL	Thermal relay	A58L-0001-0135/24	
CDR	Resistor	A40L-0001-0091/40BR010K	0.01 Ω \pm 10% 40W
DBR	Resistor	A40L-0001-0091/40BR330K	0.33 Ω \pm 10% 40W
F1 ~ 3	Fuse	A60L-0001-0036/PC1-30	UTSUNOMIYA PC1-30
F4 ~ 6	Fuse	S. FAB250/420A-P413	DAITO TSUSHIN P413
TM1, 2	Thyristor module	A50L-5000-0017	FANUC Spec.

(3) Velocity control unit for model 20H, 30H

Power Transformer

Name			Specification	Motor		
				X	Y	Z
For 200/220V	Common	Trans. A	A80L-0001-0079	10, 20, 30	10, 20, 30	10, 20, 30
		Trans. B	A80L-0001-0080	0, 5		10, 20, 30
		Trans. C	A80L-0001-0081	5, 10	5, 10	5, 10
		Trans. D	A80L-0001-0082	0		5, 10
		Trans. E	A80L-0001-0099	0		0
		Trans. F	A80L-0001-0110	0	0	0
		Trans. H	A80L-0001-0193	5, 10		5, 10
	Indi- vidual	Trans. Q	A80L-0001-0057	10kVA 200/220V 20H, 30H		
		Trans. G	A80L-0001-0192	20, 30		
For 380 420 460 480 550	Common	Trans. AE	A80L-0001-0083	10, 20, 30	10, 20, 30	10, 20, 30
		Trans. BE	A80L-0001-0084	0, 5		10, 20, 30
		Trans. CE	A80L-0001-0088	5, 10	5, 10	5, 10
		Trans. DE	A80L-0001-0089	0		5, 10
		Trans. EE	A80L-0001-0100	0		0
		Trans. FE	A80L-0001-0111	0		0
	Indi- vidual	Trans. QE1	A80L-0001-0059	10kVA 200/480V 20H, 30H		
		Trans. GE	A80L-0001-0207	20, 30		
		Trans. QE2	A80L-0001-0061	10kVA 200/550V 20H, 30H		

5.2 For M series servo unit

(1) MODEL 00M velocity control unit

A06B-6047-H001

Symbol	Name	Specification
PWB	Printed Circuit Board	A20B-0009-0320
MCC	Magnetic Contactor	A58L-0001-0158
MOL	Thermal Relay	A58L-0001-0148/5
NFB1, 2	Circuit Breaker	A60L-0001-0143/15A
RM	Resistor Module	A40L-0001-0103/B
Q1 ~ Q4	Transistor	A50L-0001-0092
DS	Diode Module	A50L-2001-0134
C1	Capacitor	A42L-0001-0095/102
ZNR	Surge Absorber	A50L-2001-0139

(2) MODEL 0M, 5M velocity control unit

A06B-6047-H002

Symbol	Name	Specification
PWB	Printed Circuit Board	A20B-0009-0320
MCC	Magnetic Contactor	A58L-0001-0151/15N
MOL	Thermal Relay	A58L-0001-0148/6
NFB1, 2	Circuit Breaker	A60L-0001-0143/15A
RM	Resistor Module	A40L-0001-0103/A
DCR	Discharging Resistor	A40L-0001-0114/A
TM1, 2	Transistor Module	A50L-0001-0091
Q1	Discharging Transistor	A50L-0001-0092
DS	Diode Module	A50L-2001-0134
D	Diode	A50L-2001-0135
C1	Capacitor	A42L-0001-0095/121
C2	Capacitor	A42L-0001-0095/102
ZNR	Surge Absorber	A50L-2001-0139

(3) **MODEL 10M, 20M velocity control unit**

A06B-6047-H003

A06B-6047-H040

Symbol	Name	Specification
PWB	Printed Circuit Board	A20B-0009-0320
MCC	Magnetic Contactor	A58L-0001-0151/15N
MOL	Thermal Relay	A58L-0001-0148/12
NFB1, 2	Circuit Braker	A60L-0001-0143/15A
RM	Resistor Module	A40L-0001-0115/A
DCR	Discharging Resistor	A40L-0001-0114/A
TM1, 2	Transistor Module	A50L-0001-0091
Q1	Discharging Transistor	A50L-0001-0092
DS	Diode Module	A50L-2001-0134
D	Diode	A50L-2001-0135
C1	Capacitor	A42L-0001-0095/121
C2, C3	Capacitor	A42L-0001-0095/102
ZNR	Surge Absorber	A50L-2001-0139

(4) **MODEL 30M velocity control unit**

A06B-6047-H004

A06B-6047-H041

Symbol	Name	Specification
PWB	Printed Circuit Board	A20B-0009-0320
MCC	Magnetic Contactor	A58L-0001-0151/15N
MOL	Thermal Relay	A58L-0001-0148/18
NFB1, 2	Circuit Braker	A60L-0001-0143/15A
RM	Resistor Module	A40L-0001-0115/B
DCR	Discharging Register	A40L-0001-0114/A
TM1 ~ 4	Transistor Module	A50L-0001-0091
Q1	Discharging Transistor	A50L-0001-0092
DS	Diode Module	A50L-2001-0134
D	Diode	A50L-2001-0135
C1	Capacitor	A42L-0001-0095/121
C2, 3	Capacitor	A42L-0001-0095/102
ZNR	Surge Absorber	A50L-2001-0139

(5) Motors and transformers for each axis

1st axis	2nd axis	3rd axis	Power supply transformer	Remarks
Model 00M, 0M	Model 00M, 0M	Model 00M, 0M	Transformer MA (MAE) (1.5 KVA)	Model 00M uses transformer output terminals 34, 35, and 36. Model 0M, 5M uses terminals 31, 32, and 33.
Model 00M, 0M	Model 5M			
Model 00M	Model 00M	Model 0M, 5M		
Model 0M, 5M	Model 0M, 5M	Model 5M	Transformer MB (MBE) (2.5KVA)	
Model 0M, 5M 10M	Model 10M			
Model 0M, 5M	Model 20M			
Model 20M, 30M				
Model 0M, 5M	Model 0M, 5M	Model 10M		
Model 0M, 5M, 10M, 20M 30M	Model 20M, 30M		Transformer MC (MCE) (5KVA)	
Model 0M, 5M, 10M, 20M, 30M	Model 0M, 5M, 10M, 20M, 30M	Model 10M, 20M 30M		
Model 30MH				

Appendix 6 Maintenance for DC servo motor

1. Outline

Proper maintenance inspection, such as check of the brush, is necessary to insure continued satisfactory operation of the DC servo motor used for driving the NC machine tool.

It is recommended that the concrete maintenance plan be made, referring to this manual, on the basis of the operating environment and operating condition in order to perform the proper maintenance inspection.

2. Reception and Storage

Immediately upon receipt of the DC servo motor, check the following items.

- Whether the DC servo motor is exactly the specified one (check the type, gear ratio and such).
- Whether there is any mechanical damage sustained in transit or not.
- Whether the rotating part can be normally turned by hand.
- In the case of the DC servo motor with brake, whether the brake is normal.
- Whether there is any loosened screw or play.

Every DC servo motor undergoes strict inspection before shipment, therefore any special receipt inspection may not be required as a rule. If the receipt inspection is particularly needed, however, it is advisable to refer to the specifications regarding the wiring of DC servo motor and detector, current, and voltage so as to make the inspection without any mistake. Don't leave the received DC servo motor outdoors, but preserve it indoors as soon as possible. Avoid storing it in the place with an extremely high or low humidity, a radical change of temperature, and dust.

If the DC servo motor is to be stored for more than one year, the brush should be removed from the DC motor. Because if the brush is left contacting the same place of the commulotor for a long time, rusting and corrosion can take place from that place, which may cause poor commutation and noise.

3. Mounting

Note the following points when mounting the DC servo motor.

- 1) The place where the DC servo motor is mounted should be so structured that check and replacement of the brush can easily be made. As the brush must be checked periodically, the structure which facilitates the check work is inevitably required.
- 2) In the case of the DC servo motor with a heat pipe (with a fan motor), design the structure of the mounting place so as to easily check and clean the cooler.
- 3) The water-proof structure of the DC servo motor is not so strict. If cutting oil, lubricating oil, etc. penetrate into the inside of the DC servo motor, these may cause poor insulation, short-circuit of the coil, defective commutator surface due to poor commutation, or abnormal wear of the brush. Therefore, due care should be taken so that the motor body will be kept away from such liquids as cutting oil and so on.

If the DC servo motor body may be dashed with such liquids as cutting oil and so on, use the DC motor of perfect water proof structure (available by optional specification). Even this type of DC servo motor, however, the extent of water-proof is that of the drip-proof motor, consequently the motor should not be used in a liquid, or should not be used at the place where a large amount of liquid splashes on the motor.

- 4) When mounting the DC servo motor on the gear box where liquid lubrication is performed, use the DC servo motor with oil seal on the output shaft. If the lip of the oil seal is always exposed to oil, there is a possibility that the oil may penetrate little by little into the inside of the motor in the course of a long time. Therefore the height of the oil level must be lower than the oil seal lip. When the DC servo motor is mounted with the output shaft upward, mount another oil seal than the one on the motor shaft so as to make the structure where the oil which passed through the first oil seal can directly flow outside.

The oil seals used for the respective DC servo motors are listed in the following.

- The DC servo motors equipped with the oil seal as the standard parts.

Motor model	Type of oil seal
Model 0, 5, 0L, 5L, 0M, 5M	AB 1017F0 (SB type)
Model 00M	AC 0382AO (SC type)

- The DC servo motors having no oil seal as the standard parts. If the oil seal is necessary, the oil seal flange should be specially specified, or the oil seal should be furnished at the machine side.

Motor model	Type of oil seal (In the case of oil seal flange)
Model 10, 20, 30, 10L 10H, 20H, 30H, 10M, 20M, 30M, 30MH	AC 2057A0 (SC type)

The oil seals used for the DC servo motors are the products of JAPAN OIL SEAL INDUSTRY Co., Ltd.

- 5) The DC servo motor is coupled with the load through the direct coupling, gears, timing belt or such. In any case the force exerted on the motor shaft must not exceed the values shown in the following table, therefore due care should be taken for the operating condition, mounting method, and mounting accuracy.

Motor model	Permissible radial load	Permissible axial load
Model 00M	25kg	8kg
Model 0, 5, 0L, 5L, 0M and 5M	70kg	20kg
Model 10, 20, 30, 10L, 10H, 20H, 30H, 10M, 20M, 30M, 30MH	450kg	130kg

- The values of permissible radial loads are the ones when the load is imposed on the end of the shaft.

The values in this table indicate the maximum permissible loads which are the sum of the constant force always exerted on the shaft owing to the mounting method (e.g., the force given by the tension of the belt when the belt coupling is used) and the force generated by the load torque (e.g., the force transmitted from the gear face).

- 6) Make the wiring between the DC servo motor and the control circuit without any mistake, just as specified in the specifications. (See the connection diagram of the machine.) A mistake made in the wiring may cause runaway or abnormal oscillation and may give damage to the motor or the machine. When the DC servo motor is run by the open loop, the relations between the signals at the respective terminals and the rotating direction are as follows.
- i) Motor power line terminals (A1 and A2).
When the positive voltage is applied to terminal A1, the DC servo motor turns clockwise when viewed from the output shaft.
 - ii) Tachometer generator terminals (G1 and G2)
When the motor rotates clockwise when viewed from the shaft, the positive voltage generates on the G1 side.
 - iii) Resolver terminals (S1, S3; S2, S4; R1, R2)
When the excitation is made by applying Cosin across terminals S1 and S3 and by applying Sin across terminals S2 and S4, thus the motor is turned clockwise, the phase of output of R1 and R2 changes to positive.
For M series.
Resolver terminals (S1, S3; S2, S4; R1, R3)
When the excitation is made by applying Cosin across terminals S1 and D3 and by applying Sin across terminals S2 and S4, thus the motor is turned clockwise, the phase of output of R1 and R3 changes to negative.
 - iv) Pulse coder terminals (A, \bar{A} ; B, \bar{B} ; Z, \bar{Z})
When the DC motor turns clockwise when viewed from the shaft, the rectangle wave whose phase leads 90° from that of the rectangle wave on terminal B, is outputted from A. The signals at terminals \bar{A} and \bar{B} have phases respectively inverse to those of A and B.

When the wiring is completed, measure the insulation between the power line and the motor frame before turning on the power. The measurement should be made with a 500V megger on a multi-tester. Further, check the insulation between the signal lines and the motor frame with a multi-tester. Be sure not to use a megger especially for measuring the insulation of the signal lines for the pulse coder.

4. Maintenance and Cleaning

4.1 Check and cleaning of motor brush

Check and clean the motor brush in the way explained in the following. If the motor brush is abnormally worn because of forgetting the check, the motor can be damaged as the result, therefore, be sure to check the motor brush.

- 1) Periodic check should be made at the intervals listed in the following as the standard.
 - In the case of a general machine tool (lathe, milling machine, machining center, or such) Every one year.
 - In the case of a machine tool with a high frequency of acceleration/deceleration (turret punch press or such) Every two months.

However, it is recommended that the check interval be determined judging the actual wear situation of the motor brush.

- 2) Confirm that the power supply to the DC servo motor (machine) is OFF. Immediately after the DC servo motor has been operated, the brush may be hot. In such a case, make the check after the brush is completely cooled.
- 3) Remove the brush cap, as shown in Fig. 4.1.1, using a screwdriver which fits to the slot.
- 4) After taking out the brush completely, measure (visually) the length of the brush (see Fig. 4.1.2). If the length of the remaining brush is shorter than 10mm (5mm in the case of Model 00), the brush cannot be used any more. Taking this fact into consideration, make a judgement as to whether the brush can be used until the next check time, and if necessary, replace the brush with a new one.
- 5) Check the brush very carefully. If any deep groove or scar is found on the contact surface of the brush or if any mark of arcing is perceived on the brush spring, replace the brush with a new one. In this case, check the brush occasionally for about a month after the replacement, and if the same situation happens during this period, contact our nearest service station.
- 6) Blow off the brush dust in every brush holder with compressed air (factory air), and the brush dust will come out through another brush holder. Before using the compressed air, confirm that the air does not contain iron dust or a large amount of moisture.
- 7) After the check, put back the brush and tighten the brush cap fully. In this case, be careful that sometimes the brush spring is caught in between the conducting metal and brush holder and the brush cap cannot go as far as the depth.

Confirm that all the brush caps are tighten into the respective brush holders to almost the same level. When putting the brush into the brush holder, sometimes the brush cannot smoothly slide due to the brush dust which adhered to the inside surface of the brush holder. In such a case, clean the inside surface of the brush holder with the tip of a screwdriver. (Take care not to scratch the commutator surface.)

- 8) When replacing the brush, use just the same brush (in the quality, shape, etc.) as the existing one. After replacement of the brush, run the DC servo motor without load for a while to fit the brush surface to the commutator surface.

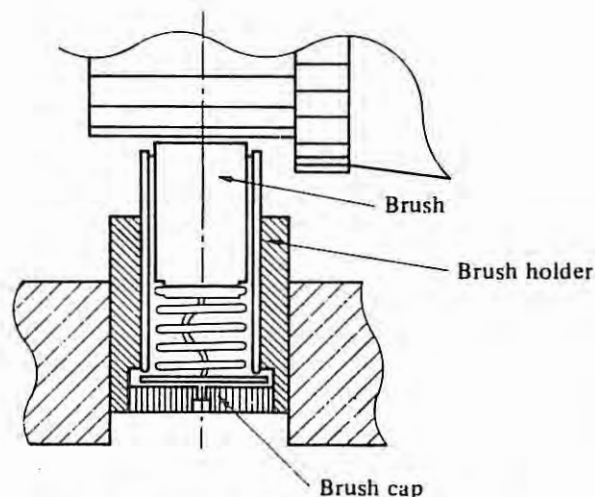
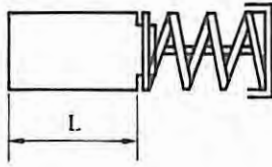

Fig. 4 (a) Structure of brush holder



Motor model	Length of new brush	Usable length
Model 00, 00M	10mm	5mm
Model 0, 5, 0L, 5L, 0M, 5M 10, 20, 30, 10L, 10M 20M, 30M, 30MH	19mm	10mm

(Motor model with H are the same as these)

Fig. 4 (b) Brush length

4.2 Cleaning of heat-pipe cooling section (In the case of MODEL 10H, 20H, 30H, 10L, 60H and 30MH)

A large amount of dust accumulated on the net and fin of the heat-pipe cooling section lowers the capability of the heat pipe, and causes troubles due to the generated heat.

- (1) When dust is accumulated on the net, which disturbs the ventilation, remove the net and clean it.
- (2) When a large amount of dust is accumulated on the fin (made up of many aluminum discs), clean the fin by blowing compressed air (factory air) to it. If the dust cannot be removed in this way, remove it with a thin rod or something like that.
- (3) Since the dirtiness at the cooling section is largely dependent on the environment conditions, the frequency of periodic cleaning should be properly determined according to the operating environment.

(Periodic check at every six months is the standard.)

4.3 Replacing method for pulse coder

(1) Replacing process

- (a) Remove M4 + screw.
- (b) Retighten the terminal G1, G2, G3, R1, R2, S1, S2, S3, S4 on the terminal box.
When use the cannot connector, remove the line A, B, C, D, E, F, G, H, J, K, N, P, T.
- (c) Remove the pulse coder.
- (d) Mount the new pulse coder and tighten M4 screw.

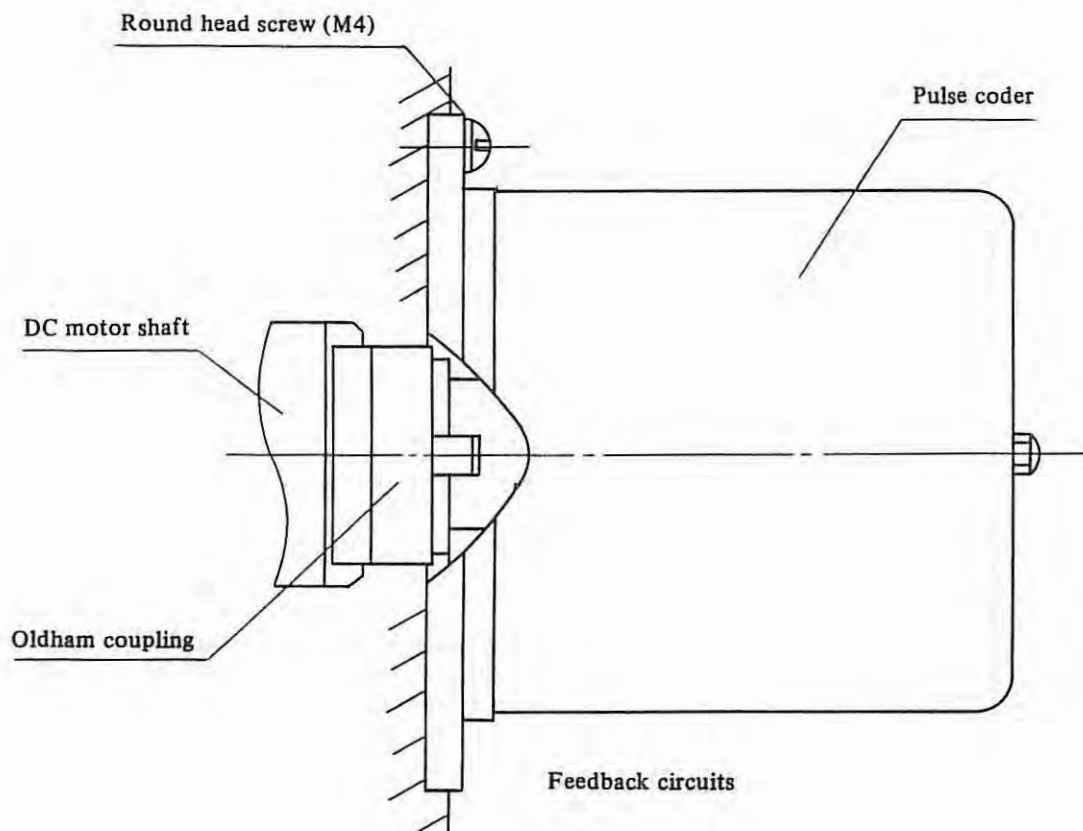

Wiring

Signal	Color	Cannon connector
A	B	A
\bar{A}	B and W	D
B	BI	B
\bar{B}	BI and W	E
Z	G	F
\bar{Z}	G and W	G
0V	Gr, Gr and W	N, P, T
5V	R and W	C, J, K

W: White B: Black BI: Blue G: Green R: Red Gr: Gray

4.4 Check of tachogenerator

The tachometer generators currently used for the DC servo motors are roughly divided into two types. In one type the tachometer generator is contained in a case as a unit, and in the other type the tachometer generator of pancake type is directly mounted on the motor shaft. In the case of the pancake-type tachometer generator, it can be cleaned without disassembling it by blowing compressed air from outside. Check the tachometer generator if any such troubles as described in the following is found.

4.4-1 Troubles caused by defective tachogenerator

When the tachometer generator is defective, the phenomena which appear on the run of the DC servo motor and machine are as follow. If any of these phenomena is found, clean the tachometer generator following the work procedures explained in the next paragraph.

- 1) Movement of machine wobbles at rapid traverse.

In most cases the vibration period is one time or two times per one turn of the motor.

- 2) The fuse of the servo unit which controls the DC servo motor blows at rapid traverse with vibration or a great shock.

As can be understand from these, the typical troubles caused by the defective tachometer generator distinctly appear when the motor is running at a high speed.

It can be considered that in most cases these troubles are caused by the defective at the brush contact of the tachometer generator. The characteristic of the tachometer generator which has been used for a long time will sometimes be degraded by the influence of the brush dust. The actual aspects of this kind of troubles are as follows.

- 1) Adjacent commutator segments are short-circuited one another by the brush dust.

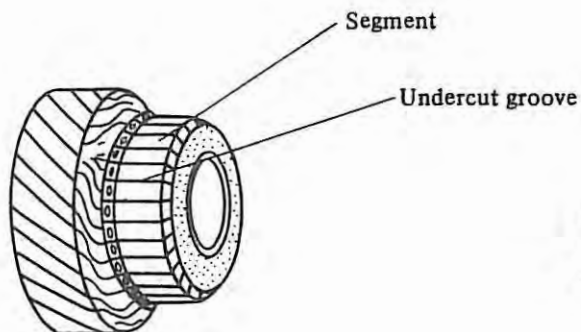

The commutator's segments are shorted when brush carbon dust has accumulated in the undercut groove.

Commutator surface

- 2) The brush cannot slide smoothly in the brush holder due to the brush dust, thereby the contact between the brush and commutator is unstable.
- 3) The contact resistance is increased due to a carbon film which thickly adheres to the commutator surface, as a result the ripple in the output increases.
- 4) The contact resistance is increased due to oil, such as cutting oil, which adheres on the commutator surface, as a result the ripple in the output increases.

The above-mentioned four examples are the typical defectives, and the troubles caused by these defectives can be removed by cleaning the tachometer generator. However, in the case of the defective described in 4) if a large amount of oil penetrates into the tachometer generator, the oil cannot be perfectly removed without disassembling and cleaning the tachometer generator. In such a case, therefore, clean the tachometer generator temporarily and replace it with a new one without leaving a long period.

4.4-2 Check and cleaning of tachometer generator (Contained in a case as a unit)

This work can be done by anyone provided he performs the disassembling, cleaning, and re-assembling following the procedures explained below. Avoid rough handling, and proceed the work calmly and slowly, strictly keeping the instructions.

Things to be prepared:

- Phillips screwdriver (small-sized) For M2 to M4
 - Slotted screwdriver (small-sized) For M2 to M4
 - Compressed air (pressure 3 to 5kg/cm²) From an air-compressor with air drying unit.
 - Writing brush (with very soft hair).
 - Clean dry cloth A couple of sheets.
 - Allen hex-type wrench For M6 (Model 10, 20, and 30)
For M4 (Model 0L and 5L)
- 1) Turn off the power so that the DC servo motor can never run. Remove the rear cover of the DC servo motor.
 - 2) Check the mounting place and its surrounding first. Clean the outside of the tachometer generator and its surrounding.
 - 3) Wash your hand with soap to completely remove oil and dirt. Wipe off the outside of the tachometer generator once again with clean dry cloth.
 - 4) See Fig. 4.4-2 (a). Remove three screws (26), and then the cover (7).

Remove the dirt.

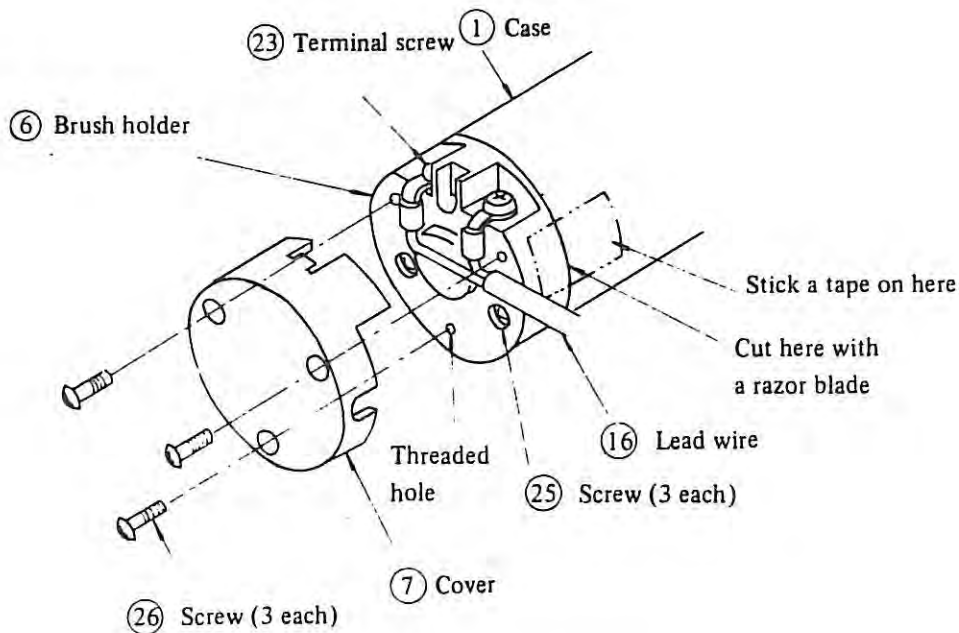

Fig. 4.4-2 (a) Cover disassembly

- 5) Check the main of the tachometer generator. Two screws (23) on the terminals of the lead wire (16), three threaded holes for screws (26), and the heads of three screws (25) can be seen. Don't loosen the three screws (25) now although if these screws are loosened, the green molded resin part of the brush holder (6) can be turned. Since this section is adjusted and set at the optimum position at our factory, it must be set at just the same position at reassembly. For this, the next procedure must be done before loosening the screw (25).
- 6) Matchmark between the case (1) and brush holder (6). As shown in Fig. 4.4-2 (a) stick a tape between the case (1) and brush holder (6) (Cellophane tape can be used. But stick it securely so that it can never come off during the work.), and cut the tape with a razor blade at the joint between the case and brush holder in order to make the separated tape the matchmark. Or make a matchmark in another proper way.
- 7) See Fig. 4.4-2 (b) Loosen three screws (25). At that time the brush holder is usually pushed out by the brush spring, therefore, hold the brush holder with hand and take out only the three screws (25). Thereby the brush holder unit (6) is ready to be removed. When the fitting portion (approx. 2mm) comes out, remove the brush holder unit slowly checking the two brushes (10) in it. If the brush side faces downward in this case, the brushes and brush springs (11) will fall down and sometimes will be lost. Therefore, remove the brush holder unit in the way that the brush side naturally comes upward as shown in Fig. 4.4-2 (b).

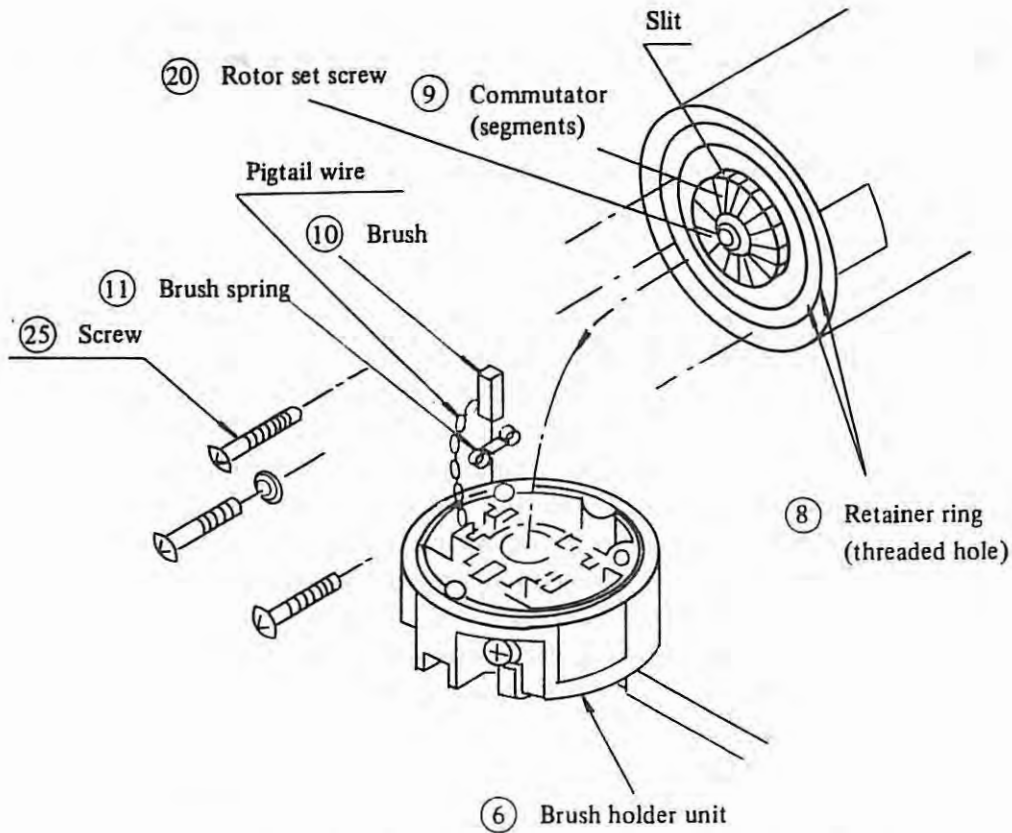

Fig. 4.4-2 (b) Disassembly of brush holder unit

- 8) Check the removed brush holder unit (6).
The two brushes (10) are pushed out by the brush springs (11). A thin pigtail wire (stranded copper wire) is attached to the side of the brush (10), and is connected to the lead wire terminal screw. If the brush did not come out yet, push it in a bit and it will come out. Pull out the brushes (10) and then taken out the brush spring (11). Since the brush spring is free in the hole, it can easily be taken out using a pin or something like that.
Check the brushes and brush springs. As these are very important parts, don't handle them roughly and don't make any scratch or deformation on them.
- 9) Cleaning of brush holder unit.
Blow off the brush dust in the brush holder with dry compressed air of 3 to 5kg/cm² using an air gun about 30cm apart from the brush holder. Don't use the air which is directly conducted from an air compressor to an air gun because it generally contains oiliness and moisture and will always cause some defectives of the tachometer generator. If the air through an air dry unit is not available, clean the brush holder with a writing hair brush (very soft one) which is used for writing Japanese calligraphy.
Don't expand the brush spring. Carefully clean particularly the sides of the brush and the brush holder hole in which the brush slides.
The brush can be used until its length becomes 4mm. If the brush length is shorter than 4mm, replace the tachometer generator with a new one.
- 10) Cleaning of commutator.
See the tachometer generator body. The commutator (9) which is radially slitted into 19 segments is set by a rotor set screw (20) in the middle. And three threaded holes for the previously removed three screws (25) can also be seen. The part with these threaded holes is called the retainer ring (8), and revolves. The commutator surface and the slits are most important here.

Clean this portion by blowing compressed air to the portion or with a thin writing brush in the way explained previously. Don't touch your hand to the commutator surface. Carefully clean the grooves of the slits in particular.

These are the procedures of disassembly and cleaning for maintenance, thereby most of the defectives can be remedied. However, if disassembly is made especially because some abnormality is found, add the following procedures.

Softly wipe the commutator surface in the radial direction from the inside to the outside with clean and soft but not nappy cloth which is slightly wet with alcohol.

Clean the inside of the slits by inserting a piece of paper about 0.3mm thick. The end of paper will become nappy in the course of the cleaning, in such a case, cut the nappy part with scissors. Don't use any other thing than paper for the cleaning. Measure the resistance (in terms of DC) between the adjacent segments 19 times in order with an ohmmeter. It will be $33 \pm 10\%$ or so. When the measured resistance is extremely small, some foreign matter remains in the slit, therefore clean the slot once again with the paper. Conversely if the resistance is extremely high, the coil is open between the segments, and this defective cannot be repaired by the user.

In order not to scratch the brush sliding surface of the commutator, apply the test lead tips of the ohmmeter to the other portion of the commutator surface.

11) Assembly [Fig. 4.4-2 (a), (b)]

Put the brush springs (11) into the brush holder (6). Be sure not to put them in inversely (Note).

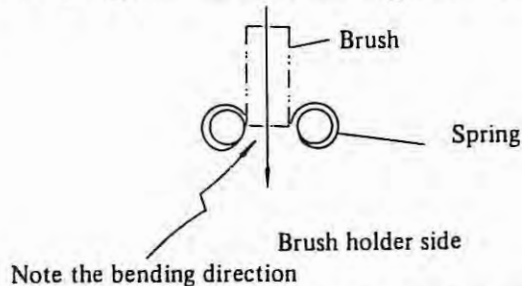

Put the brush on the brush spring. The position where the brush is to be put in can be determined referring to the pigtail wire. Try a couple of pushes to see if the brush can slide smoothly. Confirm the positions of the three threaded holes on the retainer ring (8). Mount the brush holder unit (6) to fit the positions of the threaded holes.

At that time bring the brush holder unit close to the main body in a slant, and mount it on the main body checking that the brushes are touched to the commutator surface and then gradually pushed in. Check the movement of the brushes a couple of times.

Then place the three screws (25). If the positions of the screws and the threaded holes are not fit, find the threaded holes, rotating the brush holder unit. When the screws are almost screwed in, completely align the matchmark of tape made at disassembling by carefully rotating the brush holder unit, then tighten the screws. Take off the matchmark tape. Put the cover (7) on the main body and the work is completed.

Note: If the direction of the spring is inverse, the brush will not go in when lightly pushed by finger. Note that the spring may be broken down if the brush is forcibly pushed in.

4.4-3 Cleaning of tachometer generator (In the case of pancake-type tachometer generator built in motor shaft)

Although there are some differences between the pancake-type tachometer generator according to the types of DC servo motors, basically they are built in the motor as shown in Fig. 4.4.3-3. Clean the brush and commutator in the procedures explained in the following.

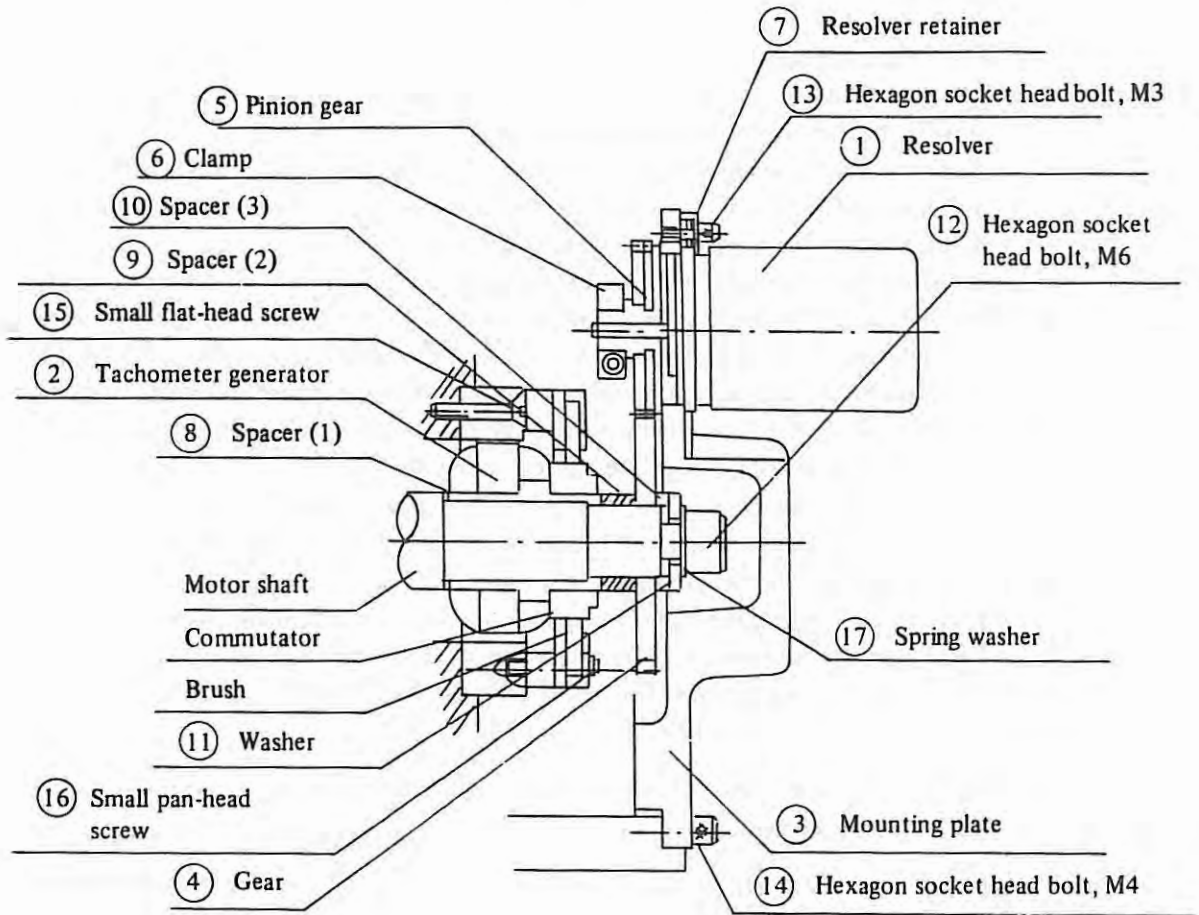

Fig. 4.4-3 Pancake-type tachometer generator mounting diagram

1) **In the case of DC servo motor without resolver.**

When a resolver is not built in the DC servo motor, the brush and commutator can be seen by removing only the rear cover because the mounting plate (3) and gear (4) do not exist. In this case cleaning of the commutator can be performed after removing only the rear cover of the motor, therefore, perform the cleaning in the following procedures.

- (1) Blow dry air to the commutator surface. Most of the defectives caused by the brush dust can be remedied by this.

Loosen the hexagon socket head bolt, M6 (12) which fixes the rotor of the tachometer generator in order to remove the brush dust in the segment grooves under the brushes, thereby the rotor can be freely rotated by hand.

Blow dry air to the segment grooves, slowly rotating the rotor by hand. If the rotor is pulled toward the front in this case, the brush may sometimes be broken by being pushed by the commutator riser, therefore do the work very carefully.

If the trouble cannot be remedied by this work, perform further the following cleaning.

- (2) Remove the brush holder after removing two small pan-head screws (16), check whether the movement of the brush is smooth. If the brush is caught, remove the brush dust adhering to the brush guide section, and burr, etc. with a thin screwdriver or something like that.
- (3) Take out the motor, and carefully remove the dust in the segment grooves. Then check the resistance between every one of the adjacent segments.

When the measured resistance is 20 to 30 over the whole circumference, it is normal. If any measured resistance is extremely high (e.g., several hundred ohms), the winding is open somewhere between the segments.

In such a case, replace the tachometer generator with a new one. If any measured resistance lower than 20 is found, there is a short circuit between the segments, therefore clean further the segment grooves. The cleaning should be made with a piece of rather thick paper (Don't use any metal piece).

- (4) When the commutator surface is covered with a thick carbon film, wipe it off using a piece of cloth wet with alcohol.
- (5) If the commutator surface is rough, the tachometer generator cannot be used any more, therefore replace it with a new one.
- (6) To reassemble the tachometer generator, reverse the disassembly and removal procedures. At assembling the brush holder if it is mounted as it is, the brush will be hit by the side of the commutator and will be broken. Push in the brush to the depth with the point of an automatic pencil or something like that, thus the spring pushes the side of the brush, and the brush stays at the depth. Then mount the brush holder in this state. By pushing the brush at its back, the brush comes out again to contact the commutator. Precisely align the matchmark between the brush holder and the magnet before tightening the mounting screws of the brush holder. Set the brush holder at the position where the length of the protrusions of the four brushes from the brush holder look almost even (concentrically).

If the alignment is not precise, there is a possibility that the ripple may increase.

The matchmark is already made to indicate the optimum positions of the rotor, magnet, and brush holder so as to minimize the ripple by perfect alignment of the three parts. Therefore, avoid replacing only one of the parts with a new one, instead replace the whole tachometer generator with a new one. However, replacement of the brushes is feasible.

If one of the parts should be replaced from some unavoidable reason, remove the DC servo motor from the machine and make it free running, then set the parts to the optimum position so as to minimize the ripple from the tachometer generator, observing the ripple with a synchroscope.

2) Cleaning of the tachogenerator

The tachogenerator using a multipolar resolver is mounted on the DC servo motor as illustrated in Figure 4.3.4.

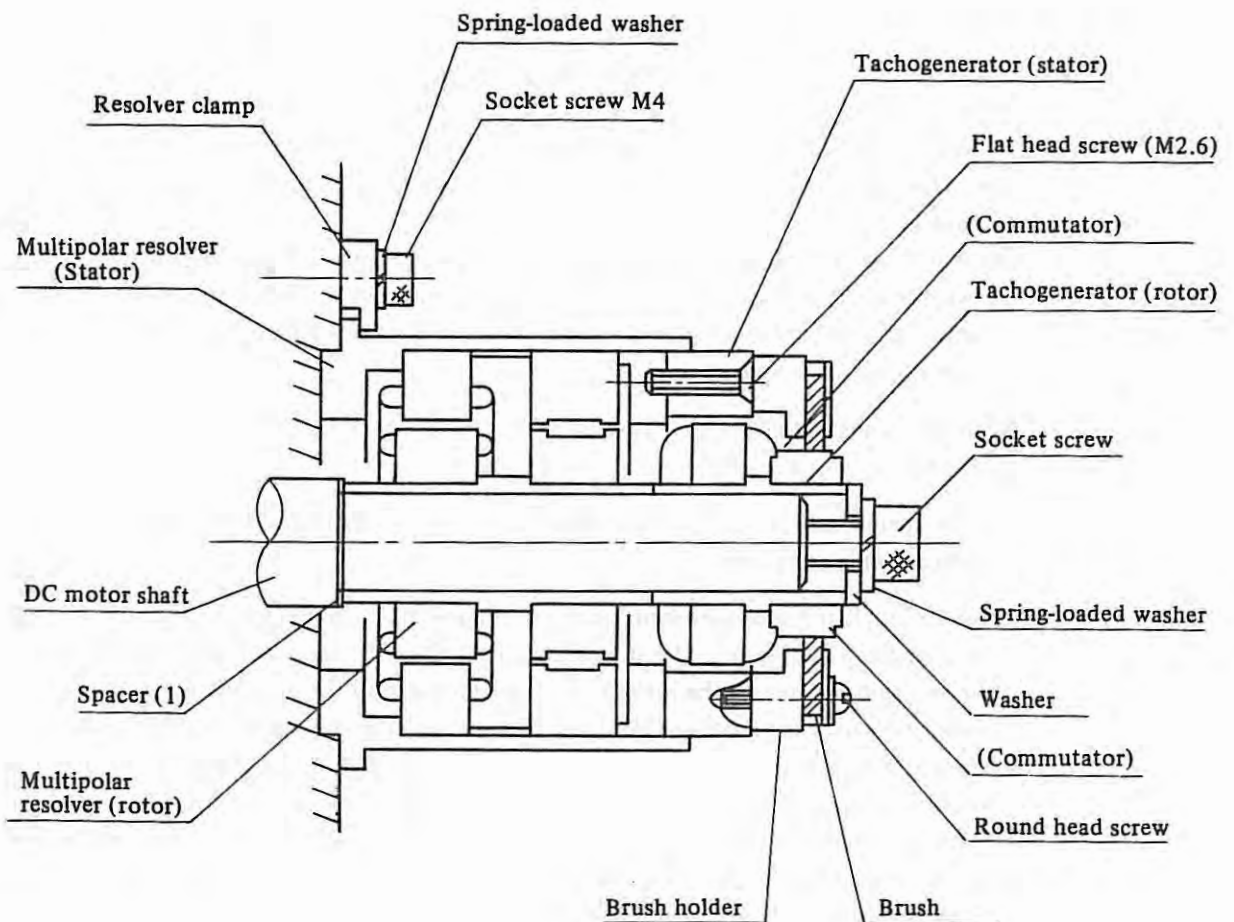

Fig. 4.3.4 Pancake-type tachogenerator

The tachogenerator not using a multipolar resolver is basically equal to that using a multipolar resolver except that a spacer mechanism (instead of the multipolar resolver) is included in the tachogenerator.

The back cover should only be removed from the DC servo motor when the tachogenerator is cleaned. Be especially careful of the group of lead wires (to the cannon connector fixed at the back cover from detectors) when the back cover is removed from the DC servo motor.

The retaining ring of the cannon connector should be removed from the back cover so that loose connections in the connector can be avoided when the tachogenerator is cleaned.

- (1) Blow dry air to the commutator surface. Most of the defectives caused by the brush dust can be remedied by this. Blow dry air to the tachogenerator with rot. If the trouble cannot be remedied by this work, perform further the following cleaning.
- (2) Remove the brush holder after removing two small pan-head screws 16, check whether the movement of the brush is smooth. If the brush is caught, remove the brush dust adhering to the brush guide section, and burr, etc. with a thin screwdriver or something like that.
- (3) Take out the motor, and carefully remove the dust in the segment grooves. Then check the resistance between every one of the adjacent segments. When the measured resistance is 20 to 30 over the whole circumference, it is normal. If any measured resistance is extremely high (e.g., several hundred ohms), the winding is open somewhere between the segments.

In such a case, replace the tachogenerator with a new one. If any measured resistance lower than 20 is found, there is a short circuit between the segments, therefore clean further the segment grooves. The cleaning should be made with a piece of rather thick paper (Don't use any metal piece).

- (4) When the commutator surface is covered with a thick carbon film, wipe it off using a piece of cloth wet with alcohol.
- (5) If the commutator surface is rough, the tachogenerator cannot be used any more, therefore replace it with a new one.
- (6) To reassemble the tachogenerator, reverse the disassembly and removal procedures.

At assembling the brush holder if it is mounted as it is, the brush will be hit by the side of the commutator and will be broken. Push in the brush to the depth with the point of an automatic pencil or something like that, thus the spring pushes the side of the brush, and the brush stays at the depth. Then mount the brush holder in this state. By pushing the brush at its back, the brush comes out again to contact the commutator. Precisely align the matchmark between the brush holder and the magnet before tightening the mounting screws of the brush holder. Set the brush holder at the position where the length of the protrusions of the four brushes from the brush holder look almost even (concentrically).

If the alignment is not precise, there is a possibility that the ripple may increase. The matchmark is already made to indicate the optimum positions of the rotor, magnet, and brush holder so as to minimize the ripple by perfect alignment of the three parts. Therefore, avoid replacing only one of the parts with a new one, instead replace the whole tachogenerator with a new one. However, replacement of the brushes is feasible. If one of the parts should be replaced from some unavoidable reason, remove the DC servo motor from the machine and make it free running, then set the parts to the optimum position so as to minimize the ripple from the tachogenerator, observing the ripple with a synchroscope.

3) In the case of DC servo motor with a resolver.

- (1) In the case of a DC servo motor with a resolver, the commutator of the tachometer generator can be seen through the opening of the mounting plate (3), therefore clean the commutator by blowing dry air to it through the opening. In order to blow dry air to all over the circumference of the commutator, rotate the commutator by means of manual feed from the NC or of a command for an extremely low speed.
Carefully perform this work making the power ready to be immediately turned off in case any unexpected oscillation generates.
- (2) If the trouble cannot be removed by this work, it is necessary to clean the commutator after removing the resolver and gear. Perform the cleaning in the following procedures. However, if unclear points or any points where you feel diffident for the work remain after reading this manual, contact our office.
- (3) Remove the hexagon socket head bolt M4 (14). Then the mounting plate (3) can be removed with the resolver.
- (4) Remove the hexagon socket head bolt M6 (12), then the washer and spacer.
- (5) Remove the gear (4) using a pulley puller or the something like this. Be careful not to make any scratch on the gear teeth surface in this case. In case any scratch is made by the puller catching the teeth surface, replace the gear with a new one.
- (6) The procedures hereafter are the same as those for the DC servo motor without resolver. Proceed the work following the description of the previous paragraph.
- (7) Note the following points at reassembly.
 - Since the fitting between the gear (4) and the shaft is tight, mount the gear onto the shaft lightly hammering the gear. When the gear goes in as far as about its thickness, insert the spacer (3) (10) between the gear and the bolt (12) and tighten the bolt until the rotor of the tachometer generator is completely fixed. If the tightening is weak, there is a possibility that the gear and the tachometer generator slip each other, therefore tighten the bolt firmly.
 - When replacing the mounting plate (3), it is safer to do it after once removing the resolver. (Because if pushing the mounting plate into the rabbet and making engagement of the gears are done at the same time, it is feared that the resolver shaft may be bent or that the gear may be damaged by forcibly pushing in the mounting plate without complete engagement of the gears.)
 - When mounting the resolver in the case where the minilash gear (two pieces of gears are united together into one) is equipped, make engagement of one piece of the gear, then twist the other piece to fully one side with the point of an automatic pencil (the point of pencil which is protruded) or some thin point like that, then back the gear piece about two teeth from that position and make engagement of the gear piece.
 - In the case of the machine for which the zero point is determined by making the grid point of the resolver, the readjustment of the zero return position becomes necessary when this work is done.

4.5 Check of resolver gear

When the resolver gear wears out or drops out, it causes run-away of the machine. To prevent this, check it in one year checking period or thereabout, and when burrs are found out on the tooth face or the tooth is cracked, replace it.

5. Cautions

(1) Brake

The brake which is built in the DC servo motor is the spring set brake of non-excitation type which operates on 100V AC power line. As the brake operates on AC power, the connection of the lead wires must be changed according to the frequency of power line.

If the wiring is wrong, there is a possibility that the coil may be burned down or chattering is generated at absorption of the moving magnet core. Therefore confirm the wiring before turning on power. When the brake is needed to be temporarily released at installation of the machine, turn the knob of manual release fully clockwise. And after the work is finished, turn the knob fully counterclockwise to restore the state where the brake is applied at turning off the power. Immediately after this state is restored by means of the manual release knob, sometimes the brake disc is not normally pushed, consequently the brake torque becomes low. In such a case, try turning on and off the power several times to remove the trouble.

(2) DC motor with pulse coder.

Since a disc made of glass is used in the pulse coder, avoid giving such extremely great shocks as hammering the DC motor and so on. As for the DC servo motor, there are not particular points to be periodically checked except the maintenance described in paragraph 4. In the event that the DC servo motor does not work normally, contact the FUJITSU FANUC Office. In general, avoid disassembling the motor or such work.

6. Spare Parts

As the spare parts, at least one set of motor brushes should always be kept for each DC servo motor.

Motor model	Length of new brush	Usable length	Specification of brush	Number of spare brushes per set
00	10mm	5mm	A290-0631-V001	2
00M			A290-0632-V001	2
0, 5, 0L, 5L	19mm	10mm	A290-0601-V001	4
0M, 5M			A290-0641-V001	4
10, 20, 30			A290-0601-V001	8
10M, 20M, 30M			A290-0651-V001	4
10L			A290-0601-V001	12

Appendix 7 Maintenance for Character Display Unit

(1) Adjustment

In general, an adjustment of character display is not required. However, for the adjustment of brightness and contrast when required, variable resistors are provided in the side panel of display unit with an indication as shown brightness (B) and contrast (C). Perform the adjustment of these two resistors. (Refer to Fig. 1. 1)

(Note 1) The display unit, being applied a high voltage of 10 to 11 kV, should be taken care when the power is ON.

(Note 2) In the case when a signal cable is disconnected, picture face becomes fully white.

Brightness (BRIGHT)

Brightness of the full portion of picture can be adjusted, and the adjustment must be normally made in such manner with the back-ground darkened when displaying the character.

- Raster (scanning line) is made not visible in the background for the contrast at maximum. (with the character becoming brightest)
- Raster must be made not visible in the background for the contrast at minimum. (with the character becoming darkest)
- Being affected by a condition of peripheral brightness, the raster must be made not visible when becoming dark.

And for the operation of above adjustment, which is made for providing a better contrast, a trick of the work is to adjust the brightness immediately before the raster is seen.

Contrast (CONTRAST)

- The contrast, a difference of brightness, becomes an adjustment of character brightness, because the back-ground has been made to zero brightness by the above described adjustment.

Make adjustment to easy-to-see brightness. Care should be taken not to excessively raise the contrast that may deform a figure of the character.

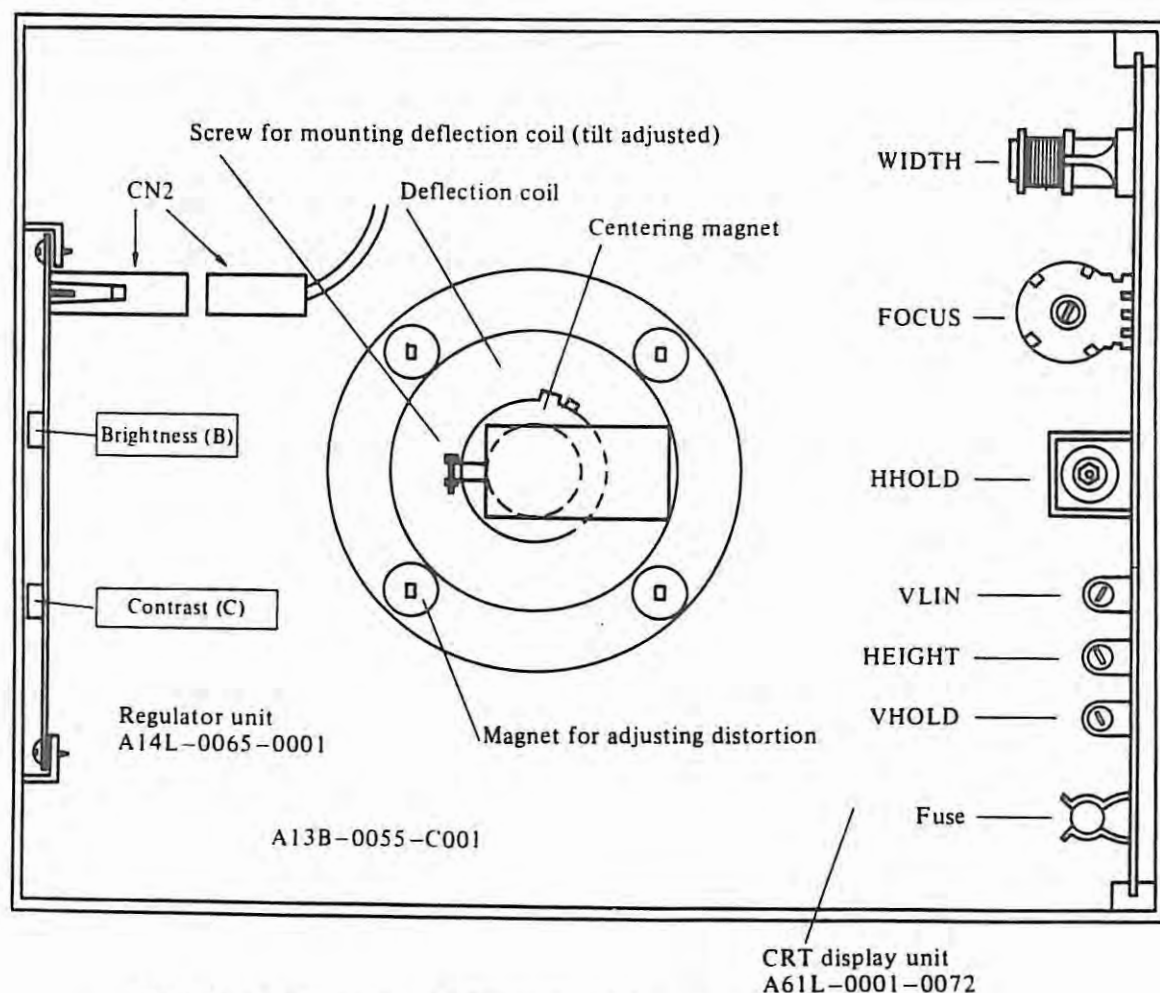

Fig. 1. 1 Adjustment point (when as viewed from rear of the display unit)

(2) Particular adjustment

For repairing defects of the picture, flowing, distorted, tilted, etc., the following adjustment points are provided in the CRT display unit side. The adjustment is normally not required but becomes necessary after the replacement of CRT and deflection coil and the like.

(a) Picture distortion and position adjustment

The adjustment must be made by a distortion adjusting magnet, centering magnet, and the screw for mounting deflection coil.

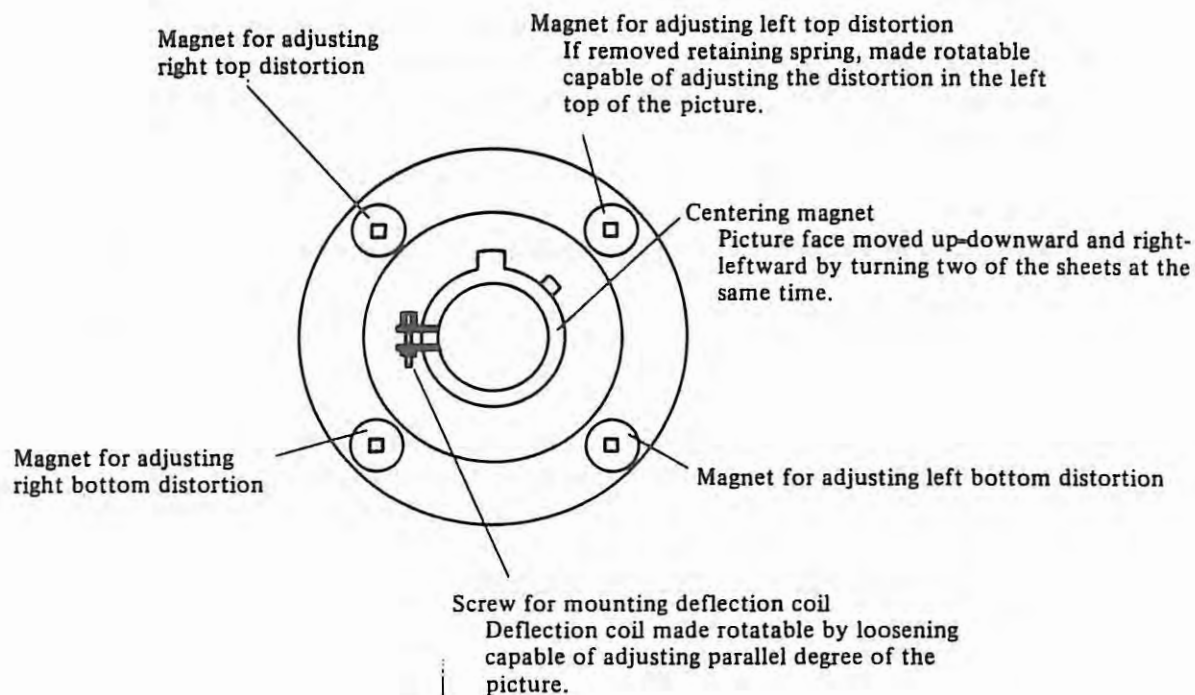

Fig. 1.2 (Deflection coil when as viewed from the rear of CRT)

- (b) Adjustment of synchronization, focus, linearity, etc.
Adjustment must be made by a use of variable resistor, coil, etc. on PCB in the CRT display unit.

WIDTH Size of the picture horizontally changed.

FOCUS Character made clearer.

H. HOLD Horizontal synchronization to stop right-left flowing of the picture.

V. LIN Vertical linearity. Capable of vertically equalizing size of character in top and bottom stage.

HEIGHT Vertical amplitude to vertically change a size of picture.

V. HOLD Vertical synchronization to stop up-downward flowing of the picture.

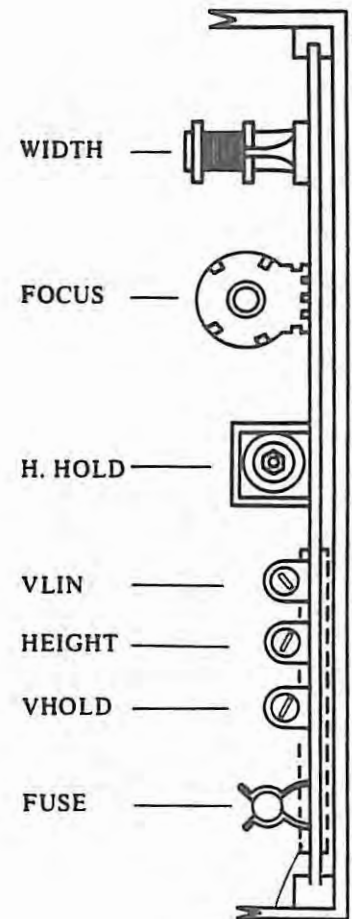

Edge connector

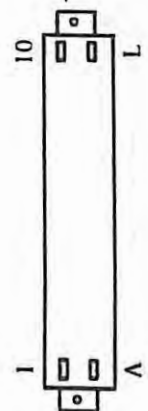

- (c) Fuse
The fuse for CRT display unit power source
1.6A 125V Rush durable type

Fig. 1.3

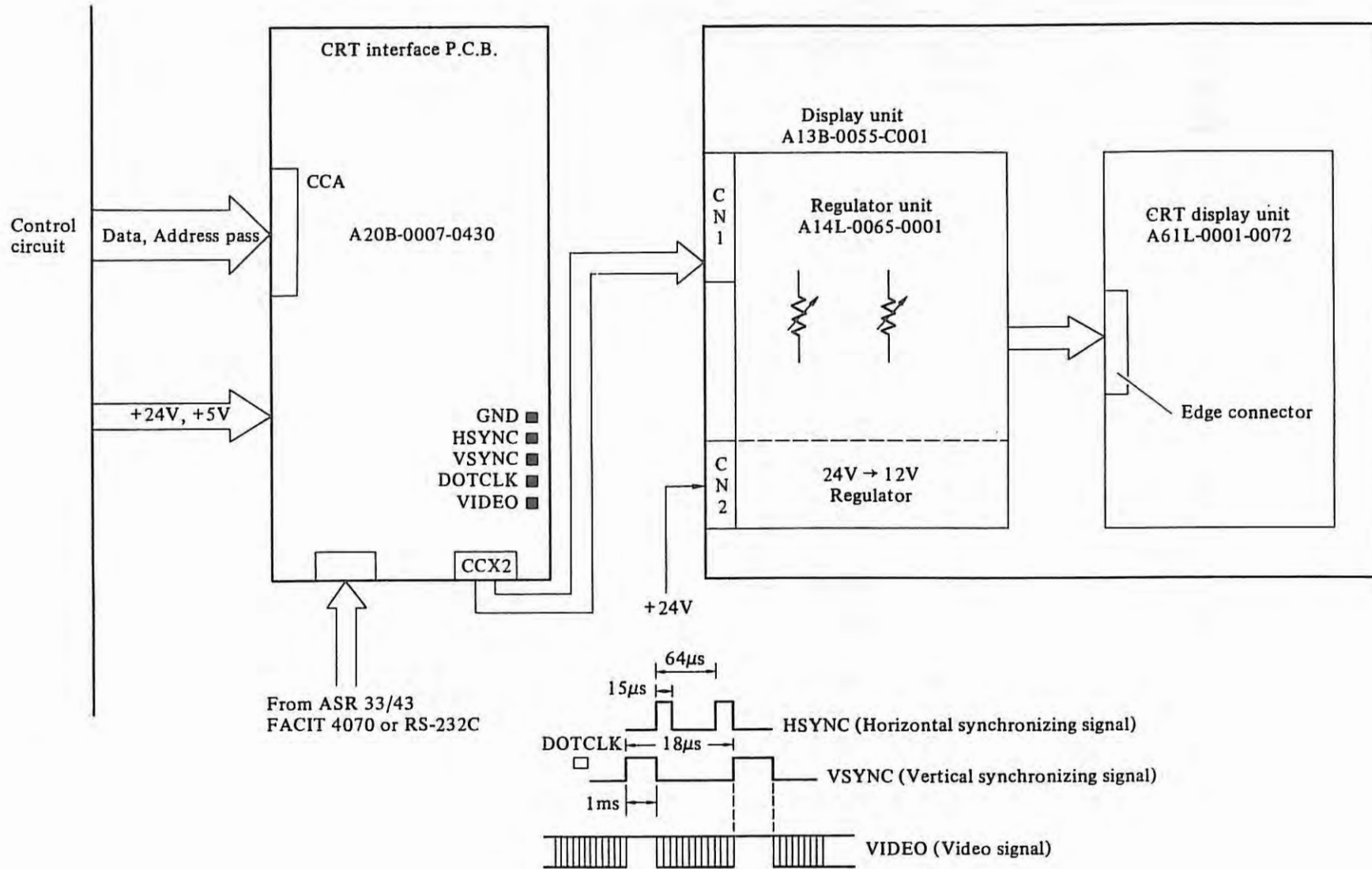
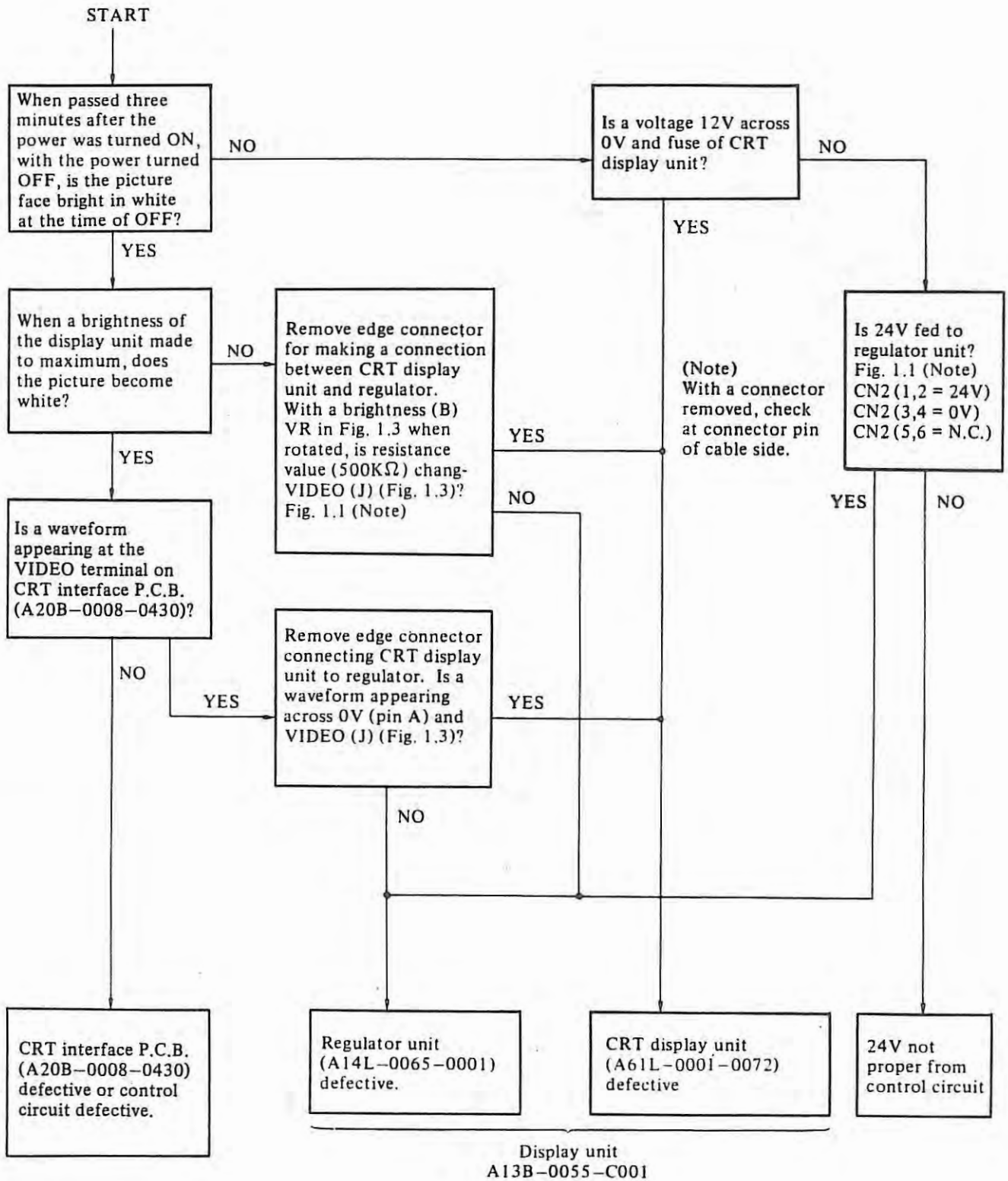

Fig. 1.4 Block diagram of character display

(3) Flow chart of trouble shooting

(a) Not displayed



(b) Flowing the picture

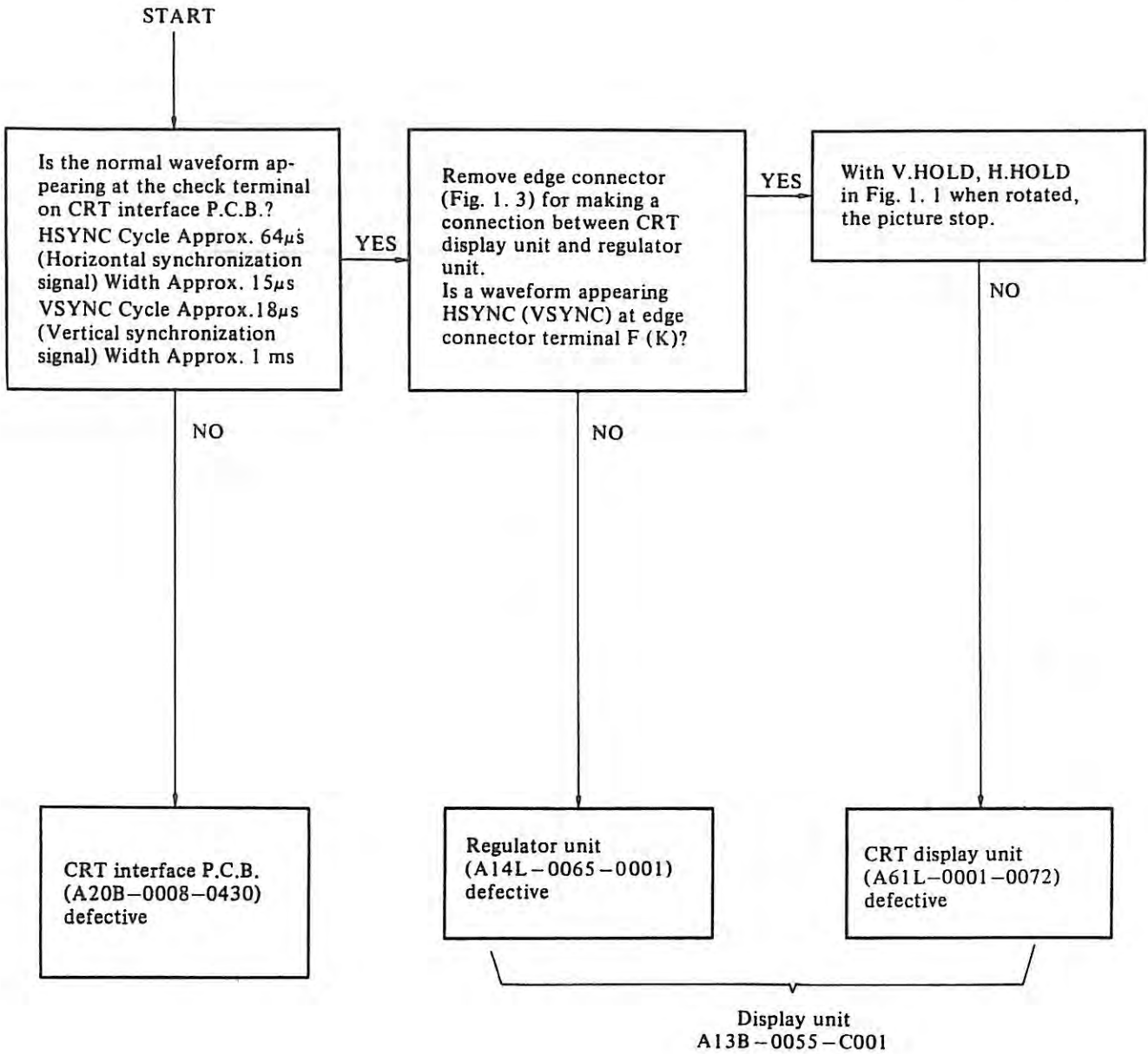

Appendix 8 Operation Table

Classification	Function	Key SW	Parameter Enable Switch	Mode Switch	Page	Operation
Clear	Bubble Memory All Clear		○	Power ON	-	[0] + [DELETE]
	Clearing Parameter		○	Power ON	-	[CAN] + [DELETE]
	Clearing Stored Program			Power ON	-	[RESET] + [DELETE]
Data Input from Tape	Parameter		○	Emergency Sw. ON	PARAM	[P] → -9999 → [READ]
	Offset value			TAPE	-	[START]
	Program Input	○		EDIT	-	[0] → Program No. → [READ]
	Add Program	○		EDIT	-	[0] → [CAN] → [READ]
	Many Program Registration	○		EDIT	-	[0] → -9999 → [READ]
Data Input from MDI	Parameter		○	MDI	PARAM	[N] → Parameter No. → [INPUT] → [P] Data → [INPUT] → * * Parameter Enable Switch OFF → [RESET]
	Offset value			ANY mode (without EDIT)	OFSET	(NOTE) [N] → Offset No. → [INPUT] ⊕ $\begin{matrix} \text{M} \\ \text{T} \end{matrix}$ → Offset Data → [INPUT]
	Setting Data	○		MDI	SET	CURSOR to set No. → [P] Data → [INPUT]
Tape Punch	Parameter			EDIT	PARAM	[P] → -9999 → [PUNCH] (NOTE)
	Offset value			EDIT	OFSET	[P] → -9999 → [PUNCH] ⊕ $\begin{matrix} \text{M} (6M): \text{P} \\ \text{T} (6T): \text{X}, \text{Z}, \text{R}, \text{T} \end{matrix}$
	Pitch Error Compensation			EDIT	PARAM	[P] → -9998 → [PUNCH]
	All Program			EDIT	-	[0] → -9999 → [PUNCH] [U], [W]
	One Program			EDIT	-	[0] → Program No. → [PUNCH]

Classification	Function	Key SW	Parameter Enable Switch	Mode Switch	Page	Operation
Searchh	Program No. Search (MEMORY mode only)			EDIT	PRGRM 1	<input type="button" value="O"/> → Program No. → <input type="button" value="↓"/> (CURSOR)
					PRGRM 2	<input type="button" value="O"/> → <input type="button" value="CAN"/> → <input type="button" value="↓"/> (CURSOR)
	Sequence No. Search (MEMORY mode only)			MEMORY	PRGRM	Program No. Search → <input type="button" value="N"/> → Sequence No. Search → * * <input type="button" value="↓"/> (CURSOR)
	Sequence No. Search (Tape mode)			TAPE	PRGRM	<input type="button" value="N"/> → Sequence No. → <input type="button" value="↓"/> (CURSOR)
	Address word search			EDIT	PRGRM	Searching Address and Data Input → <input type="button" value="↓"/> (CURSOR)
	Address search			EDIT	PRGRM	Searching Address → <input type="button" value="↓"/> (CURSOR)
Program Editing	Deletion of all Program	<input type="radio"/>		EDIT	PRGRM	<input type="button" value="O"/> → -9999 → <input type="button" value="DELETE"/>
	Deletion of a program	<input type="radio"/>		EDIT	PRGRM	<input type="button" value="O"/> → Program No. → <input type="button" value="DELETE"/>
	Deletion of several Blocks	<input type="radio"/>		EDIT	PRGRM	<input type="button" value="N"/> → Sequence No. → <input type="button" value="DELETE"/>
	Deletion of a Block	<input type="radio"/>		EDIT	PRGRM	Search the Block to be Deleted → <input type="button" value="EOB"/> → <input type="button" value="DELETE"/>
	Deletion of a word	<input type="radio"/>		EDIT	PRGRM	Search the word to be Deleted → <input type="button" value="DELETE"/>
	Alternation of a word	<input type="radio"/>		EDIT	PRGRM	Search the word to be Altered → Address → Data → <input type="button" value="ALTER"/>
	Insertion of a word	<input type="radio"/>		EDIT	PRGRM	Search the word before the place in the program → Address → * * Data → <input type="button" value="INSRT"/>
	Arrangement of Memory	<input type="radio"/>		EDIT	(PRGRM)	<input type="button" value="C"/> → <input type="button" value="ORIGIN"/>
Comparison	Comparison in Memory with Tape			EDIT	(PRGRM)	<input type="button" value="/"/> → <input type="button" value="READ"/>
	Comparison from Current position			EDIT	(PRGRM)	<input type="button" value="EOB"/> → <input type="button" value="READ"/>

Classification	Function		Key SW	Parameter Enable Switch	Mode Switch	Page	Operation
Bubble cassette	Heading of file	Heading of cassette			EDIT mode	PRGRM	<input type="text" value="N"/> → 0 (Zero) → <input type="text" value="INPUT"/>
		Next file			EDIT mode	PRGRM	<input type="text" value="N"/> → 9999 → <input type="text" value="INPUT"/>
		Automatic heading of next file			EDIT mode	PRGRM	<input type="text" value="N"/> → 9998 → <input type="text" value="INPUT"/> (Modal)
		File No. designation			EDIT mode	PRGRM	<input type="text" value="N"/> → File No. → <input type="text" value="INPUT"/>
	Deletion of file		○		EDIT mode	PRGRM	<input type="text" value="N"/> → File No. (k) → <input type="text" value="START"/> File No. (k + 1) ~ n → k ~ (n - 1)
	Output of one program				EDIT mode	PRGRM	<input type="text" value="O"/> → Program No. → <input type="text" value="PUNCH"/>
	Output of all programs				EDIT mode	PRGRM	<input type="text" value="O"/> → -9999 → <input type="text" value="PUNCH"/>
	Loading of programs				EDIT mode	—	Heading of file → <input type="text" value="O"/> → -9999 → <input type="text" value="READ"/>
	Output of offset data				EDIT mode	OFSET	<input type="text" value="P"/> → -9999 → <input type="text" value="PUNCH"/>
	Input of offset data				EDIT mode	—	Heading of file → <input type="text" value="O"/> → Program No. → <input type="text" value="READ"/> → Program execution
	Output of parameters				EDIT mode	PARAM	<input type="text" value="P"/> → -9999 → <input type="text" value="PUNCH"/>
Input of parameters			○	Emergency stop ON	PARAM	Heading of file → <input type="text" value="P"/> → -9999 → <input type="text" value="READ"/>	

Appendix 9 Tape Code Used for Programming

ISO code									EIA code									Meaning
Character	8	7	6	5	4	3	2	1	Character	8	7	6	5	4	3	2	1	
0			○	○	○				0			○		○				Numeral 0
1	○		○	○	○	○		○	1					○			○	" 1
2	○		○	○	○	○	○		2					○			○	" 2
3			○	○	○	○	○	○	3				○	○			○	" 3
4	○		○	○	○	○	○		4					○	○			" 4
5			○	○	○	○	○	○	5				○	○	○		○	" 5
6			○	○	○	○	○	○	6				○	○	○	○		" 6
7	○		○	○	○	○	○	○	7					○	○	○	○	" 7
8	○		○	○	○	○	○	○	8					○	○			" 8
9			○	○	○	○	○	○	9				○	○	○		○	" 9
A		○				○		○	a		○	○		○			○	Address A
B		○				○		○	b		○	○		○			○	" B
C	○	○				○		○	c		○	○	○		○		○	" C
D		○				○	○		d		○	○		○	○			" D
E	○	○				○	○	○	e		○	○	○	○	○		○	" E
F	○	○				○	○	○	f		○	○	○	○	○		○	" F
G		○				○	○	○	g			○	○	○	○	○	○	" G
H		○			○	○			h		○	○		○	○			" H
I	○	○			○	○		○	i		○	○	○	○	○		○	" I
J	○	○			○	○		○	j		○		○	○			○	" J
K		○			○	○	○	○	k		○		○	○			○	" K
L	○	○			○	○	○	○	l		○		○	○	○		○	" L
M		○			○	○	○	○	m		○		○	○			○	" M
N		○			○	○	○	○	n		○		○	○			○	" N
O	○	○			○	○	○	○	o		○			○	○		○	Not used at significant data zone in ISO code. Assumed as address 0 at EIA code.
P		○		○	○				p		○		○	○	○	○	○	Address P
Q	○	○			○	○		○	q		○		○	○	○			" Q
R	○	○			○	○		○	r		○		○	○			○	" R
S		○		○	○	○	○	○	s			○	○	○	○		○	" S
T	○	○			○	○		○	t			○		○	○		○	" T
U		○			○	○		○	u			○	○	○	○			" U
V		○			○	○	○	○	v			○		○	○		○	" V
W	○	○			○	○	○	○	w			○		○	○	○		" W
X	○	○			○	○	○	○	x			○	○	○	○	○	○	" X
Y		○			○	○	○	○	y			○	○	○	○			" Y
Z		○			○	○	○	○	z			○	○	○	○		○	" Z
DEL	○	○	○	○	○	○	○	○	Del		○	○	○	○	○	○	○	* Delete (cancel erroneous hole)
NUL						○			Blank					○				* No holes. Not used at significant data zone in EIA code.
BS	○				○	○			BS			○		○	○		○	* Back space
HT					○	○		○	Tab			○	○	○	○	○	○	* Tabulator
LF or NL					○	○		○	CR or EOB	○					○			End of block
CR	○				○	○		○										* Carriage return
SP	○		○			○			SP				○	○				* Space
%	○		○			○		○	ER					○	○		○	Absolute rewind stop
(○		○	○			(2-4-5)					○	○	○	○	Control out (start of comment)
)	○				○	○		○	(2-4-7)					○	○	○	○	Control in (end of comment)
+			○		○	○		○	+			○	○	○	○			* Plus sign
-			○		○	○		○	-			○		○				- Minus sign
:			○		○	○		○										Assumed as program number in ISO code.
/	○		○		○	○		○	/			○	○	○			○	Optional block skip
.			○		○	○		○	.			○	○	○	○		○	Decimal point
#	○		○			○		○										* Sharp
\$			○			○		○										* Dollar symbol
&	○		○			○		○	&				○	○	○	○		* Ampersand
'			○			○		○										* Apostrophe
*	○		○			○		○										* Asterisk
,	○		○			○		○	,			○	○	○	○		○	* Comma
;	○		○			○		○	;									* Semicolon
<			○			○		○										* Left angle bracket
=	○		○			○		○	=									* Equal mark
>	○		○			○		○	>									* Right angle bracket
?			○			○		○	?									* Question mark
@	○	○				○			@									* Commercial at mark
"			○			○			"									* Quotation mark

- (Note 1) The codes with asterisk are read in the tape memory only when it is in the comment section. They are ignored in other significant information sections.
- (Note 2) The codes with question mark are read in tape memory only when it is in comment. They generate an alarm if used in other significant information sections.
- (Note 3) With a user macro option attached, in addition, the following codes can be used in significant information.
- (,), #, *, =, E in ISO
() & , codes by parameter setting
- (Note 4) Codes not included in this table and with correct parity are always ignored.
- (Note 5) The code without correct parity generate a TH alarm. But it is ignored in a comment section and the TH alarm is not generated.
- (Note 6) A character with all eight holes punched is allowed in either ELA or ISO codes, however it will be ignored in either codes. Additionally in EIA this code will be read, but as parity error (TH) alarm.

Appendix 10 G Function Table

The following G codes are available.

Standard G code	Special G code	Special G code C	Group	Function	Basic/Option
G00	G00	G00	01	Positioning	B
G01	G01	G01		Linear interpolation	B
G02	G02	G02		Circular interpolation CW	B
G03	G03	G03		Circular interpolation CCW	B
G04	G04	G04	00	Dwell	B
G10	G10	G10		Offset value setting	O
G20	G20	G70	06	Inch data input	O
G21	G21	G71		Metric data input	O
G22	G22	G22	04	Stored stroke limit ON	O
G23	G23	G23		Stored stroke limit OFF	O
G27	G27	G27	00	Reference point return check	O
G28	G28	G28		Return to reference point	O
G29	G29	G29		Return from reference point	O
G30	G30	G30		Return to 2nd reference point	O
G31	G31	G31		Skip cutting	O
G32	G33	G33	01	Thread cutting	B
G34	G34	G34		Variable lead thread cutting	O
G36	G36	G36	00	Automatic tool compensation X	O
G37	G37	G37		Automatic tool compensation Z	O
G40	G40	G40	07	Tool nose radius compensation cancel	O
G41	G41	G41		Tool nose radius compensation left	O
G42	G42	G42		Tool nose radius compensation right	O
G50	G92	G92	00	Programming of absolute zero point Maximum spindle speed setting	B, O
G65	G65	G65	00	User macro simple calling	O
G66	G66	G66	12	User macro modal calling	O
G67	G67	G67		User macro modal call cancellation	O
G68	G68	G68	13	Mirror image for double turrets ON	O
G69	G69	G69		Mirror image for double turrets OFF	O
G70	G70	G72	00	Finishing cycle	O
G71	G71	G73		Stock removal in turning	O
G72	G72	G74		Stock removal in facing	O
G73	G73	G75		Pattern repeating	O
G74	G74	G76		Peck drilling in Z axis	O
G75	G75	G77		Grooving in X axis	O
G76	G76	G78		Thread cutting cycle	O
G90	G77	G20		01	Cutting cycle A
G92	G78	G21	Thread cutting cycle		O
G94	G79	G24	Cutting cycle B		O
G96	G96	G96	02	Constant surface speed control	O
G97	G97	G97		Constant surface speed control cancel	O
G98	G94	G94	05	Per minute feed	B
G99	G95	G95		Per revolution feed	B
-	G90	G90	03	Absolute programming	B
-	G91	G91		Incremental programming	B

B: Basic O: Option

- (Note 1) The G codes marked with are initial G codes in each group. That is, when the power is turned on or when the reset button is pressed under the status in which the system parameter by which resetting initializes G code is effective, those G codes are set. On G22 and G23, G22 is selected after the power is turned on. After resetting, G22 or G23 either of them which is effective before resetting is effected.
For G00 and G01, G98 and G99, or G90 and G91, either of them is selected for the initial G codes by setting of parameters (G00, G98, G90).
For G20 and G21, either of them which exists before cutting power or pressing the reset button is selected.
- (Note 2) The G codes in the group 00 are not modal. They are effective only in the block in which they are commanded.
- (Note 3) An alarm occurs when a G code not listed in the above table is commanded (No. 010). When an optional G code not contained in the control is specified, an alarm occurs, (No. 010). However, G60 and G61 are ignored.
- (Note 4) A number of G codes can be commanded in a block even if they do not belong to the same group. When a number of G codes of the same group are specified, the G code specified later is effective.
- (Note 5) A G code from each group is displayed.

Appendix 11 Table of Range of Command Value

		Address	Input in mm Output in mm	Input in inch Output in mm	Input in mm Output in inch	Input in inch Output in inch
Least input increment			0.001 mm	0.0001 inch	0.001 mm	0.0001 inch
Maximum stroke (distance from the reference point)			±99999.999 mm	±99999.999 mm	±3937.078 inch	±9999.9999 inch
Maximum programmable dimension		X, Z U, W I, K, R	±99999.999 mm	±3937.0078 inch	±99999.999 mm	±9999.9999 inch
At cutting feed rate override 100%	Feed per minute	F	1 ~ 15000 mm/min	0.01 ~ 600.00 inch/min	1 ~ 15000 mm/min	0.01 ~ 600.00 inch/min
	Feed per revolution		0.01 ~ 500.00 mm/rev	0.0001 ~ 50.0000 inch/rev	0.01 ~ 500.00 mm/rev	0.0001 ~ 50.0000 inch/rev
At cutting feed rate 1/10 (parameter setting)	Feed per minute	F	0.1 ~ 15000.0 mm/min	0.01 ~ 600.00 inch/min	0.1 ~ 15000.0 mm/min	0.01 ~ 600.00 inch/min
	Feed per revolution		0.001 ~ 500.000 mm/rev	0.0001 ~ 50.0000 inch/rev	0.001 ~ 500.000 mm/rev	0.0001 ~ 50.0000 inch/rev
Rapid traverse rate (Separate of for each axis)			30 ~ 15000 mm/min	30 ~ 15000 mm/min	3.0 ~ 600.0 inch/min	3.0 ~ 600.0 inch/min
Upper limit of value of cutting feed rate			6 ~ 15000 mm/min	6 ~ 15000 mm/min	0.6 ~ 600.0 inch/min	0.6 ~ 600.0 inch/min
Manual rapid traverse rate						
Fo						
Manual jog feed rate			1 ~ 2000 mm/min	0.04 ~ 78.7 inch/min	0.5 ~ 1016 mm/min	0.02 ~ 40 inch/min
Thread lead	F code	F	0.01 ~ 500.00 mm	0.0001 ~ 50.0000 inch	0.01 ~ 500.00 mm	0.0001 ~ 50.0000 inch
	E code	E	0.0001 ~ 500.0000 mm	0.000001 ~ 9.999999 inch	0.0001 ~ 500.0000 mm	0.000001 ~ 9.999999 inch
Thread cutting 1/10 (parameter setting)	F code	F	0.001 ~ 500.000 mm/rev	0.0001 ~ 50.0000 inch/rev	0.001 ~ 500.000 mm/rev	0.0001 ~ 50.0000 inch/rev
	E code	E	0.00001 ~ 99.99999 mm	0.000001 ~ 9.999999 inch	0.00001 ~ 99.99999 mm	0.000001 ~ 9.999999 inch
Maximum revolutions of spindle			5000 rpm	5000 rpm	5000 rpm	5000 rpm
Coordinate value of 2nd reference point (distance from reference point)			0 ~ ±99999.999 mm	0 ~ ±99999.999 mm	0 ~ ±3937.0078 inch	0 ~ ±9999.9999 inch
Tool offset amount			0 ~ ±999.999 mm	0 ~ ±99.9999 inch	0 ~ ±999.999 mm	0 ~ ±99.9999 inch
Minimum value in incremental feed			0.001 mm	0.0001 inch	0.001 mm	0.0001 inch

	Address	Input in mm Output in mm	Input in inch Output in mm	Input in mm Output in inch	Input in inch Output in inch
Backlash compensation amount		0 ~ 0.255 mm	0 ~ 0.255 mm	0 ~ 0.0255 inch	0 ~ 0.0255 inch
Area of stored stroke limit (value from reference point)		±99999.999 mm	±99999.999 mm	±3937.0078 inch	±9999.9999 inch
Dwell		0 ~ 99999.999 sec	0 ~ 99999.999 sec	0 ~ 99999.999 sec	0 ~ 99999.999 sec
Program number	: (ISO) 0 (EIA)	1 ~ 9999	Same as left	"	"
Sequence number	N	1 ~ 9999	Same as left	"	"
Preparatory function	G	0 ~ 99	Same as left	"	"
Spindle function	S	0 ~ 9999	Same as left	"	"
Tool function	T	0 ~ 9932	Same as left	"	"
Miscellaneous function	M	0 ~ 99	Same as left	"	"
Designation of program number	P, Q	1 ~ 9999	Same as left	"	"
Repeat time	L	1 ~ 9999	Same as left	"	"
Parameter	Angle	A	0 ~ 64	Same as left	"
	Cutting depth.	D, I, K	Same as coordinate value	Same as left	"
	Cutting time	D	1 ~ 9999	Same as left	"

Appendix 12 Status at Turning Power on and at Reset

○: The status is not changed or the movement is continued.

x: The status is canceled or the movement is interrupted.

	Item	At turning power on	At reset
Setting data	Offset value	○	○
	Data SETTING	Initial value (INCH/MM setting is not changed)	○
	Parameter	○	○
Data	Program in the memory	○	○
	Content in the buffer	x	x
	Display of the sequence number	x	○
	One-shot G code	x	x
	Mordal G code	Initial code (G20/G21 is not changed.)	No change (However, it can be changed by parameter setting) G22 and G23 are not changed.
	F function	Zero	It is not changed However, it can be changed by parameter setting)
	S, T, M function	x	○
Address L (Repetitive count)	x	x	
Coordinate system	Work coordinate value	Zero	○
Executing movement	Movement	x	x
	Dwell	x	x
	Sending of M, S or T code	x	x
	Tool offset	x	x
	Tool nose radius compensation	x	x
	Memorization of called subprogram number	x	x (Note 1)
	Rewind	x	x
Display	Alarm (ALM)	If there is no alarm, displays	Same as left
	LABEL SKIP (LSK)	Displays	In MDI mode, ○ In other modes, displays
	BUFFER	It is displayed	In MDI mode, ○ In other modes, displays
	BUFFER	It is displayed	In MDI mode, ○ In other modes, displays

	Item	At turning power on	At reset
Outputs signals	Reference point return lamp.	x	○ (x in emergency stop)
	S and T code	x	○
	M code	x	x
	M, S and T strobe signal	x	x
	Spindle revolution signal (S-12 bit/S analog signal)	○	○
	NC ready signal	ON	○
	Servo ready signal	ON (Other than servo alarm)	ON (Other than servo alarm)
	CYCLE START lamp	x	x
	FEED HOLD lamp	x	x

(Note 1) When the NC is reset during the subprogram execution, the control returns to the start of the main program. The subprogram cannot be executed from the middle of it.

Appendix 13 Bubble memory initialize

1 Introduction

When one of the following alarms occurs in FANUC SYSTEM 6, it suggests that a great error has occurred. The bubble memory must be initialized according to the following operational procedure.

Number	Contents
901	No Marker error occurs when power is turned on.
905	No Marker error occurs.
906	Many Defect Loop error occurs.

Note: Bubble memory initialize is to clear all contents of a bubble memory and rewrite data of the marker bit, defect loop, etc. in the bubble memory.

2 Operational procedure

(1) Record defect loop data.

Defect loop data of the bubble memory is indicated on its PCB. Read this according to the following procedure.

- i) Power off the NC.
- ii) Remove the bubble memory PCB from the NC master PCB.

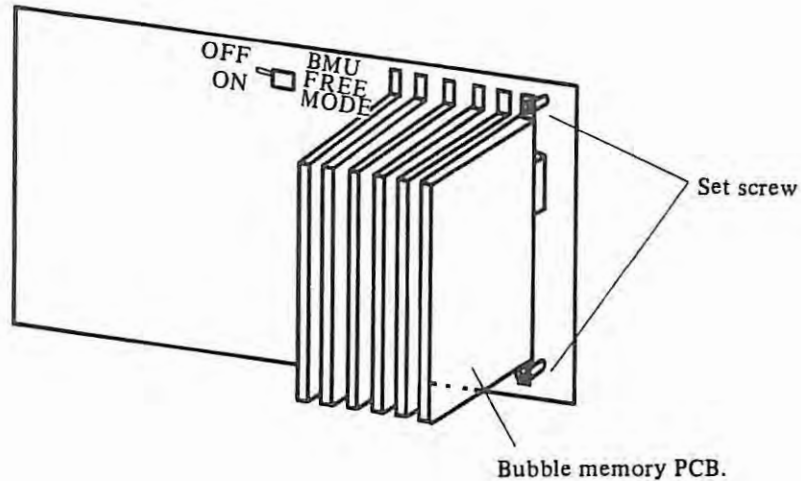

- iii) Read defect loop data indicated on the bubble memory PCB.
 a) Defect loop data is indicated in the following location.

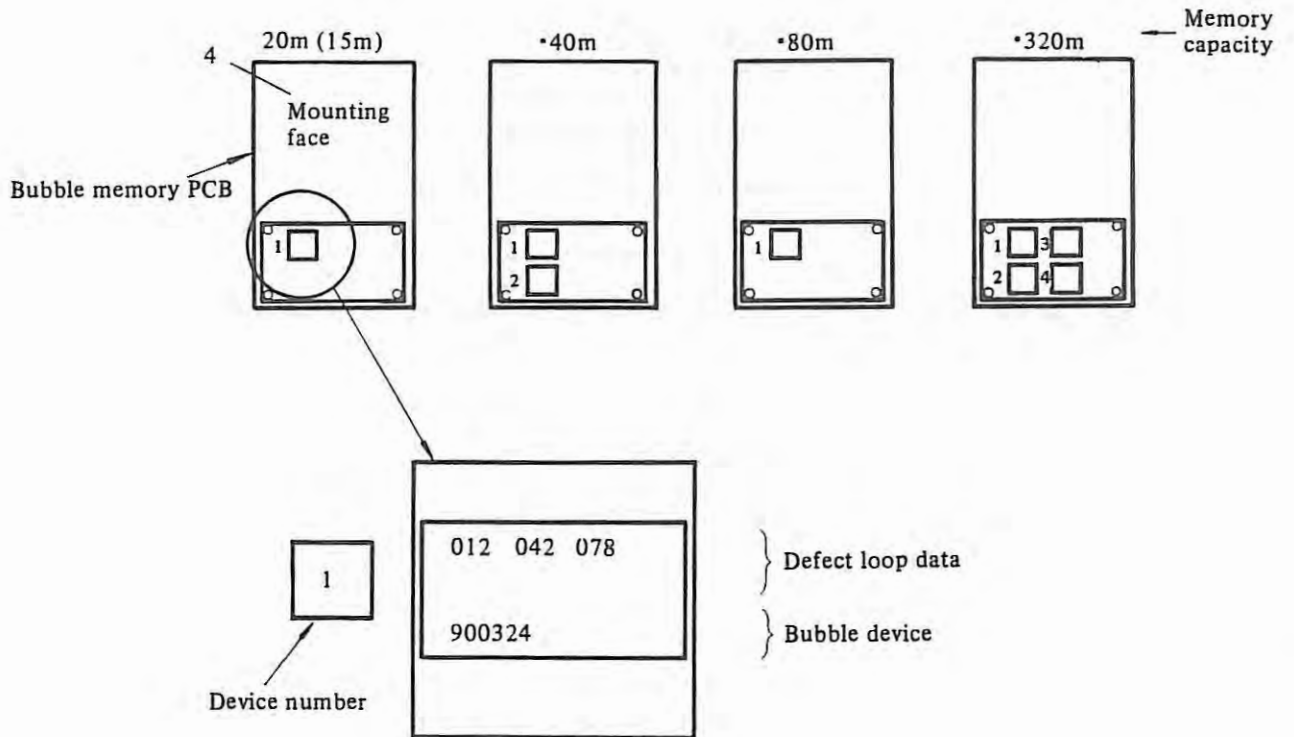

- (Note 1) The number of defect loops is indefinite and differs from device to device.
 (Note 2) The number of devices differs as below, according to the memory capacity.

Memory capacity	Device number
20m (15m)	1
40m	2
80m	1
320m	4

- (2) Bubble initialize according to the following procedure, using the MDI & CRT unit.
- i) Mount the bubble memory PCB on the master PCB, with power OFF.
 - ii) Power ON while pressing buttons and . Then the following screen will be displayed.

```

IL-MODE
1. TAPE
2. MEMORY
3. ENPANE
4. BUBBLE
5. PC-LOAD
6. RAM TEST
  
```

iii) Press button **4** . Then the following screen will be displayed.

```
BUBBLE INITIALIZE
*FUNCTION KEY
1: WRITE BY TAPE
2: WRITE BY MANUAL
3: DISPLAY LOOP-DATA
ORIGIN: RETURN TO IL-MODE
```

iv) Press button **2** . Then the following screen will be displayed. (Proceed to v) when switch BMU is ON.)

```
BUBBLE INITIALIZE
MAKE BMU-SWITCH ON
```

(Note 1) When button **1** is pressed in screen iii), bubble initialize can be performed by tape. But usually, perform it on the MDI & CRT unit.

(Note 2) When button **3** is pressed in screen iii) in a state no bubble-associated alarm has occurred, the screen proceeds to iv). Set switch BMU ON. Then the bubble defect loop will be displayed on the screen ((screen vi) is displayed.)

v) Set the master PCB switch BMU ON. Then the following screen will be displayed.

```
BUBBLE INITIALIZE
DEVICE 1

INPUT =

INPUT: INPUT LOOP DATA
DELET: CLEAR ALL DATA
START: WRITE BUBBLE
```

vi) Key in defect loop data of DEVICE1 by DATA keys and press button **INPUT** . Repeat the above operation for two or more of defect loop data.

(When keyed-in defect loop data has an error, press button **DELET**. Then all keyed-in defect loop data will be cleared. After that, enter it again.)

After defect loop data of DEVICE1 has been entered, press button **START**. Then defect loop data will be written in DEVICE1 (taking tens of seconds).

When the data is not written correctly, the following screen is displayed.

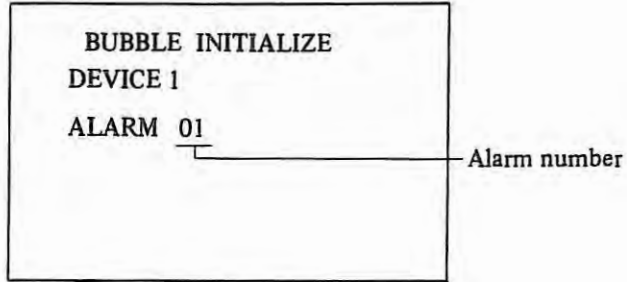

When it is written correctly, if DEVICE2, 3, and/or 4 is present, the screen proceeds to v). Enter defect loop data as in vi). When all DEVICES have been entered with, the screen will be displayed as below. Collate the entered data with the screen to make sure that the data has been written correctly. If it is erroneous, press button RESET. Then the screen will go back to iii). Repeat the operation from iv).

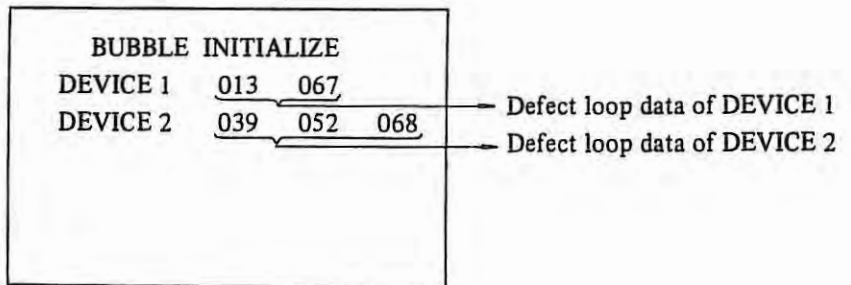

vii) Set switch BMU OFF and turn power OFF. Then turn power ON again and enter parameters again.

Power ON with pressing - and

Bubble initialize operational procedure

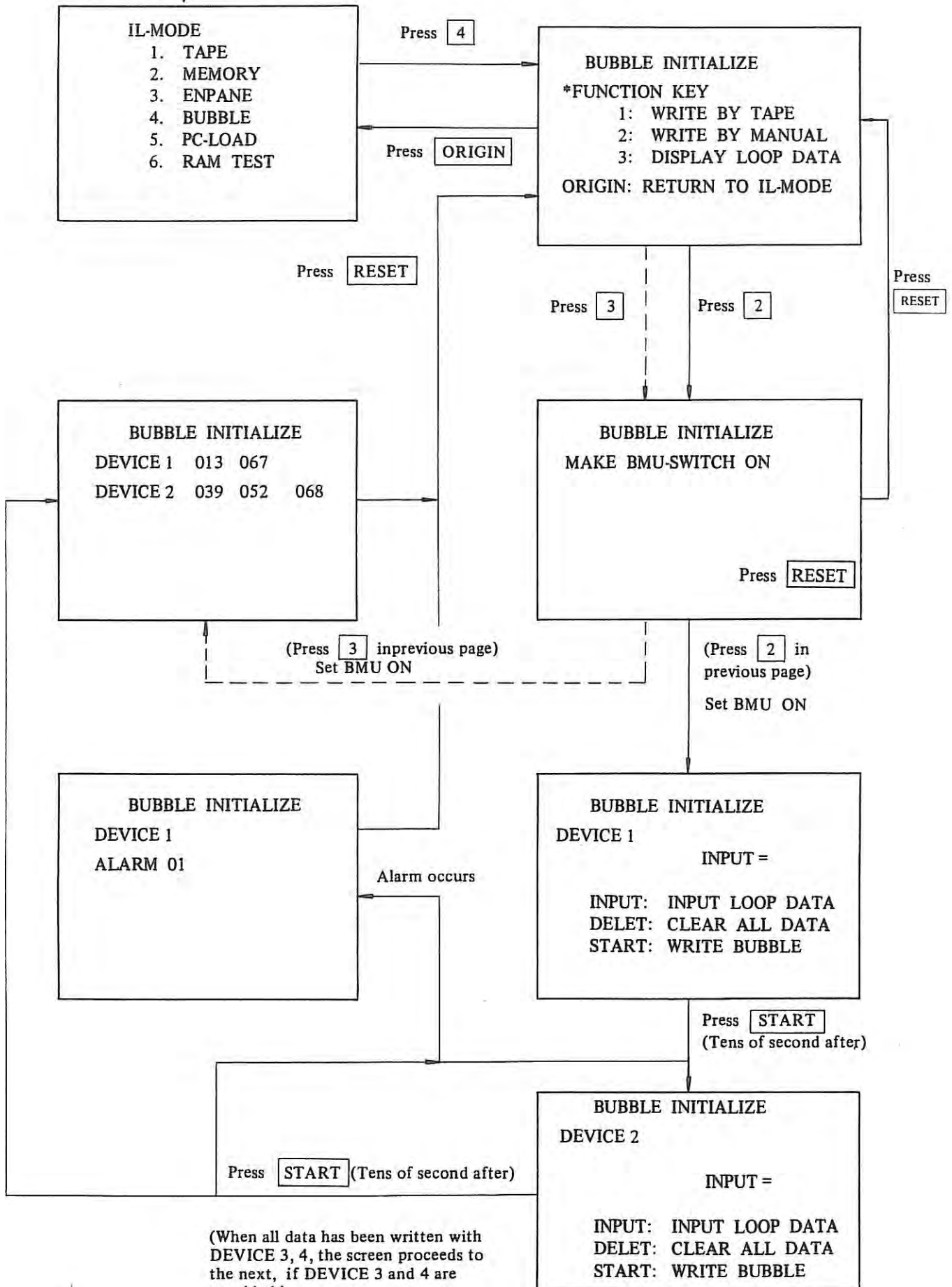

(3) List of Alarms

Alarms mentioned below are sometimes displayed on the screen during bubble memory initialize operation. Then bubble memories must be replaced. Please inform FANUC Service Center.

Number	Contents
01	Bubble device input signal is abnormal.
03	Defect loop data cannot be written in bubble.
04	Defect loop data cannot be read out of bubble.
05	Written-in defect loop data does not equal read-out data.
06	No data can be read out of bubble.
07	Bubble is not cleared.
08	Data cannot be written in bubble.
09	Marker has not been written correctly.
10	Defect loop data tape has no % (ER) at its end.

Appendix 14 RAM test

1 Introduction

When a RAM-associated alarm occurs, RAM testing displays the faulty RAM on the LED on the master PCB. Whether or not a RAM is normal, can also be diagnosed in IL-Mode after the power is turned on.

2 Operation

2.1 An alarm has occurred.

- i) Check LED master PCB display first of all. For the alarm sometimes is not displayed on the CRT screen, because of use of RAM. (See Fig. 1.)
- ii) Press the START button. The RAM test will begin.
 - o RAMs are under test (which takes approx. two seconds.)

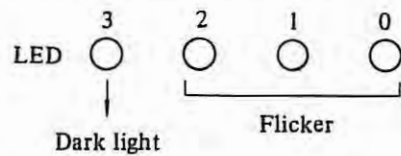

- o Faulty RAMs have been detected.

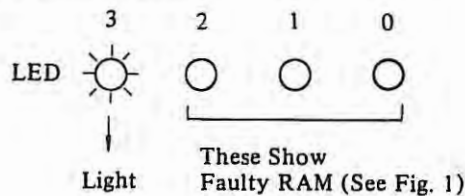

Press the START button. RAM test will continue.

- o Faulty RAMs have not been detected.

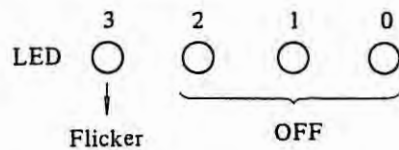

Press the START button. The test will be conducted again from the beginning of the RAMs.

- iii) Do not operate for purposes other than RAM test, until the power is turned off.

2.2 RAM test is to be conducted after the power is turned on.

- i) Power on while pressing the and buttons. The following screen will be displayed.

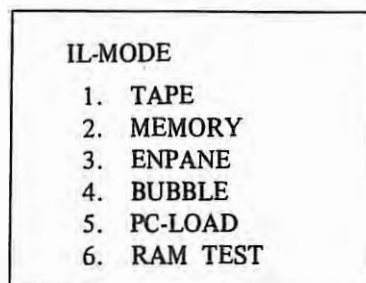

ii) Press the **6** DATA key. The LEDs will flicker.

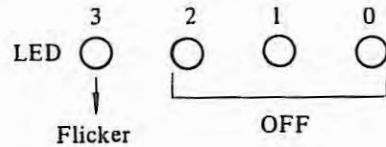

iii) Press the **START** button. The sequence will enter into 2.1, ii

iv) Press the **RESET** button. The sequence will be an ordinary software one.

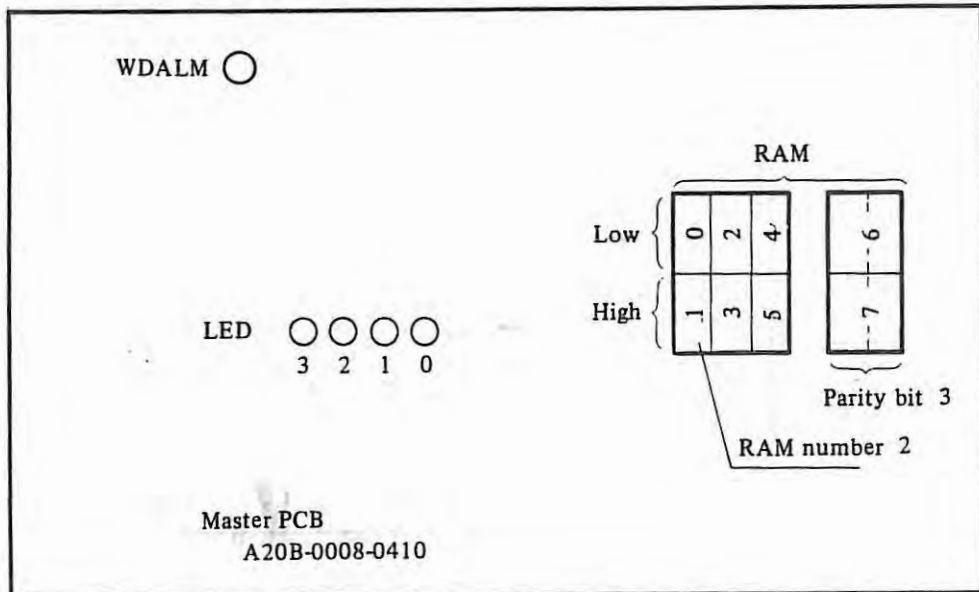

WDALM lights	Watch Dog alarm occurs.
LED ○ ○ ○ ○ 3 2 1 0	Alarm contents
x x x x	Normal
x x x ○	Slave Ready is OFF.
x x ○ x	Alarms 900-999 occur (except 910, 911).
x ○ x x	RAM parity alarm occurs. (Note)
○ x x x	RAM test shows RAM 0 to be faulty.
○ x x ○	RAM test shows RAM 1 to be faulty.
○ x ○ x	RAM test shows RAM 2 to be faulty.
○ x ○ ○	RAM test shows RAM 3 to be faulty.
○ ○ x x	RAM test shows RAM 4 to be faulty.
○ ○ x ○	RAM test shows RAM 5 to be faulty.
○ ○ ○ x	RAM test shows RAM 6 to be faulty.
○ ○ ○ ○	RAM test shows RAM 7 to be faulty.
□ x x x Flickering	RAM Test Wait or RAM Test End

○ ON
x OFF

Fig. 1

Appendix 15 Lubrication oil of tape reader

PROPERTY OF ROCOL OIL (ROCOL ASO)

Appearance		Black Fluid
Specific Gravity	15/4°C	0.91
Reaction		Neuter
Flash Point	°C	196
Viscosity (cst)	38.7°C	100
	98.9°C	9.5
Viscosity Index		75
Pour Point	°C	Below -25
Total Acid Value	mg KOH/Gr	0.02
Residual Carbon	Wt%	0.14
Corrosion, Cu 100°C for 3Hr		pass
Base oil		Mineral oil
SAE Viscosity Standard		SAE #30
Pressure Prrof Test (four-ball tester)	kg/cm ²	4.5
Ditto Abrasion	mm	1.07

PROPERTY OF ROCOL PASTE (ROCOL A.S.P.)

Appearance		Black
Specific Gravity		1.43
Miscibility	60W/25°C	280 ~ 300
Dropping point	°C	more than 70
Volatile matter 100°C X24Hr	Wt%	0.40
Corrosion, Cu		> Ia
Waterproof	38°C X1Hr	Wt% 4.35
Oxidation Stability	100°C X100Hr	kg/cm ² 0.80
Pressure Proof test (four-bäll tester)	kg/cm ²	9.0
Ditto Abrasion	mm	1.45

Base oil of ROCOL PASTE (ROCOL ASP)

Viscosity	100°F	45 ~ 55 cst
	210°F	6 ~ 7 cst
Flash Point	°C	192
Pour Point	°C	-37.5

PROPERTY OF LAUNA-OIL

Item	Brand No.	Launa-20	Launa-40	Launa-100
	Reaction		neuter	neuter
Specific Gravity 15/4°C		0.8993	0.9095	0.9081
Flash Point °C		173	211	216
Viscosity cst	@30°C	20.65	36.70	108.2
	@50°C	10.44	17.04	42.75
	@100°F	15.50	26.46	73.22
	@210°F	3.54	5.06	9.66
Viscosity Index		124	134	117
Pour Point °C		-32	-40	-40
Volatile Matter	wt% 98°C for 5Hr	0.04	0.03	0.02
Color Union		1 ½ (-)	1 ½ (-)	1 ½
Total Acied Value mg KOH/g		0.21	0.20	0.10
Corrosion, Cu 100°C for 3Hr		1A	1A	1A
Friction Value		0.14	0.13	0.14
Rust Preventing Characteristics h		24 up	24 up	24 up
Thermal Stability 140°C for 6Hr		pass	pass	pass
Angle of Contact 30°C for 24Hr		11.4	16.4	18.2

Appendix 16 Displaying and setting PC-related signals and data

1. PC screen selection (for both PC-A and PC-B)

To output the PC screen, press the MDI or CRT PARAM key. If the screen is not output, press the key again. The following will be displayed at the top of the screen.

PC PARAMETER 01 :			
NO.	DATA	NO.	DATA



2. PC screen format

2.1 For PC-A

Only one data item is displayed on a single screen.

2.2 For PC-B



A single data item or 20 data items can be displayed on a single screen.

- (1) When the PC screen is first selected, 20 data items are displayed.
- (2) To change to a single data item displayed at the upper left side of the screen, press the PAGE KEY  continuously for several seconds. Display a single data item for a quickly changing signal. Display a 20 data item screen to slow down screen changes.
- (3) To change back to the 20 data item display, hold down the PAGE key  for several seconds.

3. Signal display

To display signals (I/O signals, control relays, etc.), entered in the ladder diagram address table, on the CRT screen, perform the following operations.

3.1 For PC-A

- (1) Press the  key. 20 data items will be displayed on the CRT screen.
- (2) Press the  key.
- (3) Use the DATA key to set the address of the desired signal.
- (4) Press the  key. The data item whose address is input in (3) is displayed.

(Note) Signals in the address table can also be displayed on the PC-PARAMETER screen described in Section 1.

3.2 For PC-B

- (1) Press the PARAM key to output the PC screen. (Refer to Sections 1 and 2.)
- (2) Press the  key.
- (3) Use the DATA key to set the address of the desired signal.
- (4) Press the INPUT key. The data item whose address is input in (3) is displayed.

(Note) PC \rightleftharpoons NC and PC \rightleftharpoons MT signals can also be seen on the DIAGNOSE screen. Control relay and hold-type memory address signals can only be seen on the PC screen.

4. PC \rightarrow MT output signals

This function, using a RAM card as a PC memory, sets the output signals to the machine to "1"s or "0"s. It is effective only when the PC programmer is already connected to the RAM board. Operations described below are the same for both PC-A and PC-B.

- (1) First set the NC parameter DGNE (FS6T: Parameter Number 10 7th bit, FS6M: parameter number 11 7th bit) to "1".
- (2) Set the NC operation mode to MDI mode.
- (3) Stop PC execution. (This is done by the PC parameter.)
- (4) Display the screen that contains the address of the signal to be output. This operation is the same as Section 3.1.

- (5) Move the cursor to the address of the desired signal.
- (6) Press the ADDRESS key **[P]**.
- (7) Within the 8-bit signal for the specified address, set "1" in the bits for which output is to be "ON" and "0" in the other bits.
- (8) Press the INPUT key. The data set in (7) are output.

5. Setting the timer table

Number of timers and timer intervals to be set differ for PC-A and PC-B. (See the following table.)

Table 5.1

PC type	Timer number set by the program	Timer number set by MDI and CRT	Minimum interval setting	Maximum interval setting
PC-A	1, 2	1001, 1002	50 msec	3276.7 sec
	3 ~ 18	1003 ~ 1018	50 msec	12.7 sec
PC-B	1 ~ 8	1001 ~ 1008	50 msec	3276.7 sec
	9 ~ 40	1009 ~ 1040	8 msec	524.2 sec

(Note) Timer numbers set by MDI and CRT are formed by adding 1000 to timer numbers set by the program.

5.1 Timer Interval Table (for both PC-A and PC-B)

- (1) Select the PC screen. (Refer to Section 1.)
- (2) Press the **N** key.
- (3) Use the DATA key to set the timer number (number + 1000).
- (4) Press the INPUT key. The timer number is displayed in the NO. field of the screen, and the time interval is displayed in the DATA field. The time interval units are msec.

5.2 Setting the timer interval (for both PC-A and PC-B)

- (1) Set the NC operation mode to MDI mode.
- (2) Set the NC parameter write switch to ENABLE.

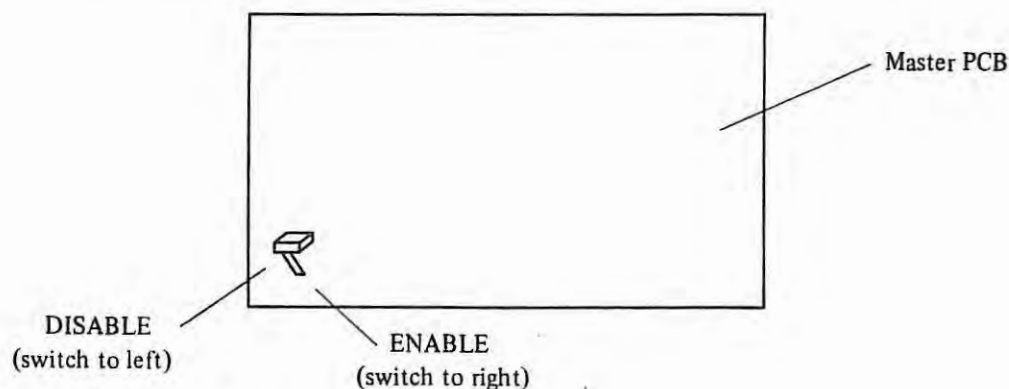

- (3) Select the PC screen. (Refer to Section 1.)
- (4) Press the **[N]** key.
- (5) Use the DATA key to set the timer number.
- (6) Press the INPUT key. The screen set in (5) is output.
- (7) If a 20 data item screen is displayed (for PC-B), move the cursor to the desired timer number.
- (8) Press the **[P]** key.
- (9) Use the DATA key to set the timer interval to an integral multiple of the minimum terval setting in Table 5.1. The fractional part is truncated.
- (10) Press the INPUT key. The specified interval is set for the specified timer number.

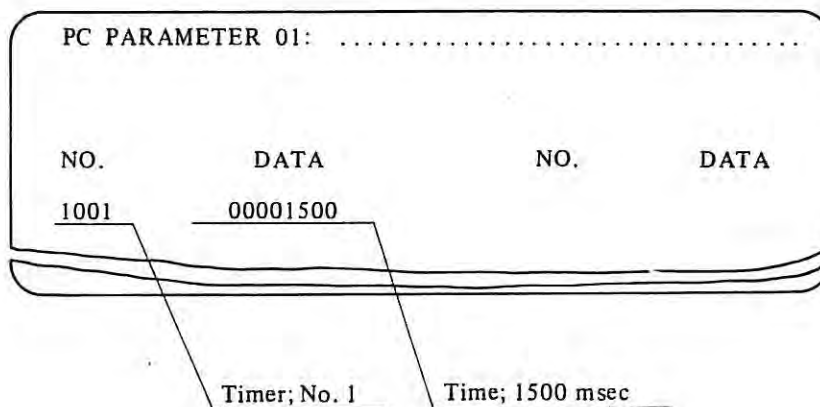

(11) Return the parameter set switch to DISABLE.

6. Setting and displaying the counter's preset value and integrated value

The following tables show numbers to specify in order to set and display intervals and counter numbers specified by the program.

For FANUC PC-MODEL A

Number to specify for CRT display Counter number specified by the program	Preset value		Integrated value	
	Decimal display	BCD bit pattern display	Decimal display	BCD bit pattern display
1	2001	596, 597	2101	604, 605
2	2002	598, 599	2102	606, 607

For FANUC PC-MODEL B

Number to specify for CRT display Counter number specified by the program	Preset value		Integrated value	
	Decimal display	BCD bit pattern display	Decimal display	BCD bit pattern display
1	2001	560, 561	2101	580, 581
2	2002	562, 563	2102	582, 583
3	2003	564, 565	2103	584, 585
4	2004	566, 567	2104	586, 587
5	2005	568, 569	2105	588, 589
6	2006	570, 571	2106	590, 591
7	2007	572, 573	2107	592, 593
8	2008	574, 575	2108	594, 595
9	2009	576, 577	2109	596, 597
10	2010	578, 579	2110	598, 599

(Note 1) Note that the number to specify in order to display the preset value is 2000 greater than the counter number specified by the program, and the number to specify in order to display the integrated value is 2100 greater than the counter number.

(Note 2) The number to specify in order to display the BCD bit pattern is the address number specified by the program.

6.1 Display

- (1) Press the PARAM key and output the PC screen. (Refer to Sections 1 and for details.)
- (2) Press the **N** key.
- (3) Use the DATA key to set the counter number (number + 2000).
- (4) Press the INPUT key. The counter number is displayed in the NO. field, and the preset value or integrated value is displayed in the DATA field.

6.2 Setting

- (1) Set the NC operation mode to MDI mode.
- (2) Turn the MEMORY PROTECT switch (machine operation panel) to OFF (KEY signal to "1").
- (3) Press the PARAM key and output the PC screen.
- (4) Press the **N** key.
- (5) Use the DATA key to set the counter number (number + 2000).
- (6) Press the INPUT key.
- (7) Press the **P** key.
- (8) Use the DATA key to set the desired numerical value.
- (9) Press the INPUT key. The numerical value set in (8) is set in the specified counter number.
- (10) Turn the MEMORY PROTECT switch (machine operation panel) to ON (Key signal to "0").

7. Setting and displaying the keep relay, sequence control section parameter, and table control data

7.1 Display

These data are displayed by specifying the address used by the program as described in Section 3 "Signal display".

7.2 Setting

The setting method is the same as described for the timer in Section 5. However, specify the bit pattern. The following table shows the correspondence between the address used in the program and the number to specify for the setting.

Address specified by the program		Number specified for CRT display
PC-A	PC-B	
600	600	3001
601	601	3002
602	602	3003
603	603	3004
	604	3005
	605	3006
	606	3007
	607	3008
	608	3009
	609	3010
	610	3011
	611	3012
	612	3013
	613	3014

8. Setting and displaying the data table

The data table is generally used to store random ATC pot and tool number correspondence tables.

8.1 Clearing the data table

- (1) Set the NC operation mode to MDI mode.
- (2) Turn the MEMORY PROTECT switch (machine operation panel) to OFF (KEY signal to "1").
- (3) Press the **PARAM** key and output the PC screen.
- (4) Press the **N** key.
- (5) Use the **DATA** key to set 4999.
- (6) Press the **INPUT** key.
- (7) Press the **P** key.
- (8) Use the **DATA** key to set 9999.
- (9) Press the **INPUT** key. The above operations clear the entire data table to zeros.
- (10) Turn the MEMORY PROTECT switch (machine operation panel) to ON (KEY signal to "0").

8.2 Setting and displaying operations

These operations are the same as the ones in Section 6 "Setting and displaying the counter". However, the number to specify for CRT display is 4000 greater than the number in the table. The following table shows these numbers.

	Number specified on MDI & CRT	Number in the table	Address
PC-A	4000	0	608
	4001	1	609
	⋮	⋮	⋮
	4030	30	638
PC-B For BCD 2 digits	4000	0	614
	4001	1	615
	⋮	⋮	⋮
	4009	99	713
PC-B For BCD 4 digits	4000	0	614, 615
		1	616, 617
	⋮	⋮	⋮
	4060	60	734, 735

8.3 Special display

By specifying NO. 4998 on the PC screen, the data table DISP data and contents of number "0" in the table are

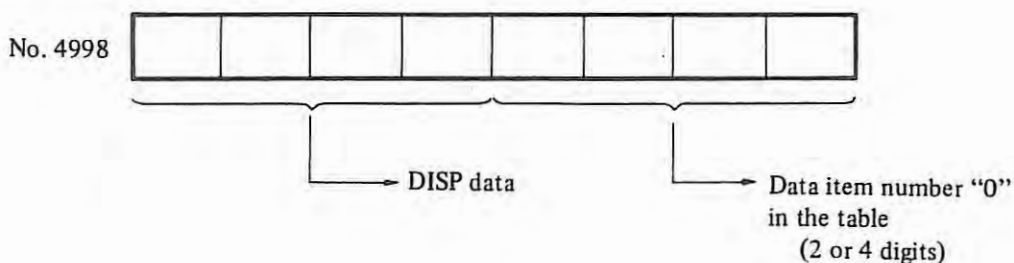

Appendix 17 Fuse specifications

Location	Symbol	Rate (A)	Specification	Remarks
Input unit	F1, F2	10	A60L-0001-0036 #PC1-10	
			A60L-0001-0042 #JG1-10	
	F3	0.32	A60L-0001-0046 #0.32	
	F4 ~ 6	15	A60L-0001-0036 #PC1-15	Value depends on transformer specification
		20	A60L-0001-0036 #PC1-20	
		30	A60L-0001-0036 #PC1-30	
	F7 ~ 9	40	A60L-0001-0042 #JG1-40	
Stabilizing unit	F11, F12	5	A50L-0001-0101 #P450H	
Velocity control unit (H series)	F7 ~ F9	1	A60L-0001-0046 #1.0	On the firing PCB. For X axis, 4th axis
	F1 ~ 3	15	A60L-0001-0118	For DC motor model 0.5
		30	A60L-0001-0036 #PC1-30	For DC motor model 10, 20, 30, 10H
		40	A60L-0001-0036 #PC1-40	For DC motor model 20H, 30H
	F4~F6	1.3	SFab250 402A P413	For DC motor model 10, 20, 30, 10H, 20H, 30H

Each unit uses same symbol (F1). So please take care of each symbol.

Revision Record

FANUC SYSTEM 6T MODEL B MAINTENANCE MANUAL (B-52245E)

04	'82 11	<ol style="list-style-type: none"> 1. Adding Bubble memory PCB A87L-0001-0084 ~ 0086. 2. Adding MDI keyboard PCB A20B-0007-540. 3. Adding connection unit A20B-0008-0540. 4. Adding stabilizing unit A14B-0061-B002. 5. Adding the explanation of M series servo unit. 6. Adding the alarm 417, 427, 701, 907 ~ 909, 912. 7. Adding the DGN No. 124, 715. 8. Adding the explanation of 3000 ppr pulse coder. 9. Adding the parameter CLSI (No. 20), FMT No. 24), CKIM (No. 26), No. 315, PCFBK (No. 316), No. 336, No. 337, No. 363, No. 364, No. 387. 			
03	'81 10	Setting and adjustment of DC servo unit (M series), trouble shooting of reference point return, and correction of error.			
02	'81 5	Correction of error. Addition of item trouble shooting, and setting, parameter and trouble shooting for resolver or inductosyn.			
01	'80 11		04	'82 11	<ol style="list-style-type: none"> 10. Adding the setting and adjustment of AC spindle servo unit. 11. Adding the operation of bubble cassette. 12. Correction of error.
Edition	Date	Contents	Edition	Date	Contents