

2. Block Diagram

6MBP20JB060

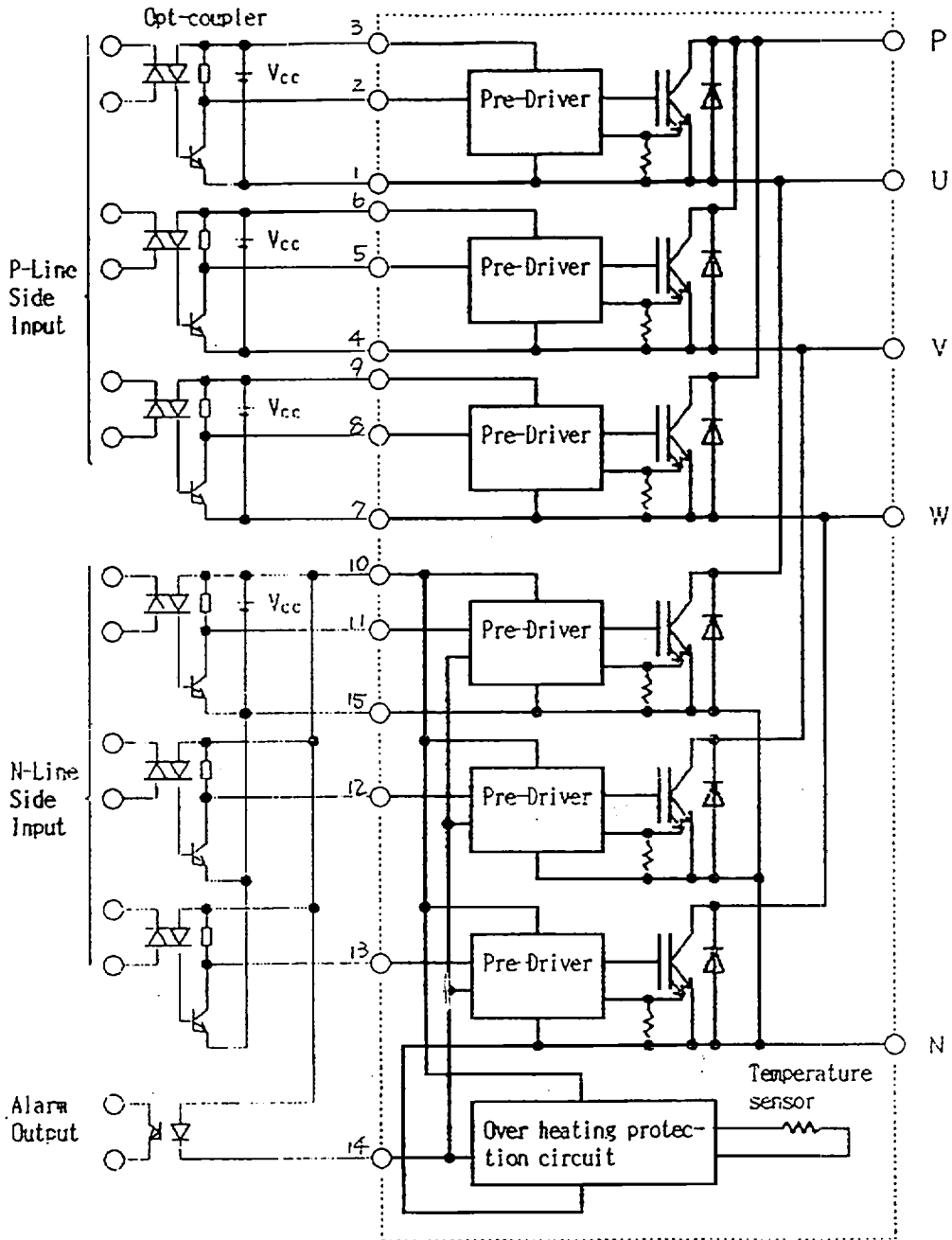

This material and the information herein is the property of Fuji Electric Co., Ltd. They shall be neither reproduced, copied, lent, or disclosed in any way whatsoever for the use of any third party nor used for the manufacturing purposes without the express written consent of Fuji Electric Co., Ltd.

- Pre-Drivers include following functions
- ① Short Circuit Protection Circuit
 - ② Amplifier for Driver
 - ③ Under Voltage Lockout Circuit
 - ④ Over current Protection Circuit

	DATE	NAME	APPROVED
DRAWN	- -		
CHECKED	- -		
REVISIONS			

Fuji Electric Co., Ltd.

DWG. NO.

MS6M0065

2/1

✓	✓
✓	✓
✓	✓

3. Absolute Maximum Ratings (Tc=25°C)

Items	Symbols	Rated Values	Unit
DC Bus Voltage	V _{DC}	450	V
Collector Current	DC	I _C	20
	1ms	I _{CP}	40
	DC	-I _C	20
Collector Power Dissipation	One Transistor	P _C	50
Junction Temperature	T _J	150	°C
Input Voltage of Power Supply for Pre-Driver	V _{CC} ±1	20	V
Input Signal Voltage	V _{IN} ±2	V _{CC}	V
Alarm signal output Voltage	V _{ALM} ±3	V _{CC}	V
Alarm signal current	I _{ALM} ±4	20	mA
Storage Temperature	T _{STG}	-40~125	°C
Isolation Voltage (Case-Terminal)	V _{ISO} ±5	AC2000	V
Mounting Screw Torque (M4)	—	1.7 ±6	N·m

- * 1 : V_{CC} shall be applied to the input Voltage between terminal No③ and ①, ⑥ and ④, ⑨ and ⑦, ⑩ and ⑮.
- * 2 : V_{IN} shall be applied to the input Voltage to terminal No②, ⑤, ⑧, ⑪, ⑫, and ⑬.
- * 3 : V_{ALM} shall be applied to the Voltage between terminal No⑭ and ⑮.
- * 4 : I_{ALM} shall be applied to the input current to terminal No⑬.
- * 5 : 50Hz/60Hz sine wave 1 minute.
- * 6 : Recommendable Value : 1.3 ~ 1.7 N·m

4. Electrical Characteristics

4.1 Electrical Characteristics of Power Circuit (Tj=25°C, V_{CC}=15V)

Items	Symbols	Conditions	Min.	Typ.	Max.	Unit
Collector Current at OFF Signal Input	I _{CES}	T _J = 25°C V _{CE} =600V	—	—	1.0	mA
Collector-Emitter Saturation Voltage	V _{CE(sat)}	I _C = 20A	—	—	2.5	V
Forward Voltage of FWD	V _F (-I _C)	-I _C = 20A	—	—	③3.0	V

This material and the information herein is the property of Fuji Electric Co., Ltd. They shall be neither reproduced, copied, lent, or disclosed in any way whatsoever for the use of any third party nor used for the manufacturing purposes without the express written consent of Fuji Electric Co., Ltd.

REVISIONS			
CHECKED	- -		
DRAWN	- -		

DATE	NAME	APPROVED

Fuji Electric Co., Ltd.

DWG. NO. **MS6M0065** 3/1

3/1	3/1	3/1
-----	-----	-----

4.2 Electrical Characteristics of Control Circuit (Tj=25°C, Vcc=15V)

Items	Symbols	Conditions	Min.	Typ.	Max.	Unit
Operating Power Supply Voltage Range of Pre-Driver	V _{cc}	Recommendable Value	13	15	17	V
Power Supply Current of P-Line Side Pre-driver (One Unit)	I _{ccp}		—	—	12	mA
Power Supply Current of N-Line Side Three Pre-Drivers and Protection Circuits	I _{ccn}		—	—	40	mA

Over Heating Protective Section (Vcc=15V)

Items	Symbols	Conditions	Min.	Typ.	Max.	Unit
Over Heating Protection Temperature Level	T _{OH}	—	90	95	100	°C
Hysterisis	T _H	—	—	10	—	°C

Over Current Protective Section (Tj=25°C, Vcc=15V)

Items	Symbols	Conditions	Min.	Typ.	Max.	Unit
Over Current Protection Level	I _{oc}	— #7 Fig.1	23			A

Short Circuit Protective Section (Tj=25°C, Vcc=15V)

Items	Symbols	Conditions	Min.	Typ.	Max.	Unit
Short Circuit Protection Level	V _{sc}	— #8 Fig.2	—		400	V

Alarm Signal Output Section (Tj=25°C, Vcc=15V)

Items	Symbols	Conditions	Min.	Typ.	Max.	Unit
Alarm Signal Hold Time	t _{ALM}	— #9 Fig.3	100	—	—	μs

Under Voltage Lockout Section (Tj=25°C, Vcc=15V)

Items	Symbols	Conditions	Min.	Typ.	Max.	Unit
Under Voltage Protection Level	V _{cc}	—	11.0	12	12.5	V
Hysterisis	V _H	—	0.2	—	—	V

This material and the information herein is the property of Fuji Electric Co., Ltd. They shall be neither reproduced, copied, lent, or disclosed in any way whatsoever for the use of any third party nor used for the manufacturing purposes without the express written consent of Fuji Electric Co., Ltd.

REVISIONS			

DATE	NAME	APPROVED	Fuji Electric Co.,Ltd	
DRAWN				
CHECKED			DWG.NO.	MS6M0065
				4/7

5. Dynamic Characteristics ($T_j=25^\circ\text{C}$, $V_{cc}=15\text{V}$)

Items	Symbols	Conditions	Min.	Typ.	Max.	Unit
Switching Time	t_{on}	$I_c = 20\text{A}$ $V_{DC} = 300\text{V}$ $V_{to} = 0\text{V}$ *10 Fig 4	—	—	2.0	μs
	t_{off}		—	—	3.0	μs
	t_r		—	—	0.5	μs

6. Thermal Characteristics

Items		Symbols	Min.	Typ.	Max.	Unit
Junction to Case Thermal Resistance	IGBT	$R_{th(j-c)}$	—	—	2.5	$^\circ\text{C/W}$
	FWD	$R_{th(j-c)}$	—	—	4.0	$^\circ\text{C/W}$
Case to Fin Thermal Resistance with Compound		$R_{th(c-f)}$	—	0.05	—	$^\circ\text{C/W}$

This material and the information herein is the property of Fuji Electric Co., Ltd. They shall be neither reproduced, copied, lent, or disclosed in any way whatsoever for the use of any third party nor used for the manufacturing purposes without the express written consent of Fuji Electric Co., Ltd.

a)	
b)	
REVISIONS	

DATE	NAME	APPROVED
- -		
- -		

Fuji Electric Co., Ltd.				
DWG. NO.	MS6M0065			
	5/7			
	<table border="1"> <tr><td>A</td></tr> <tr><td>B</td></tr> <tr><td>C</td></tr> </table>	A	B	C
A				
B				
C				

*.9 Fig.3 Alarm Signal Output Logic

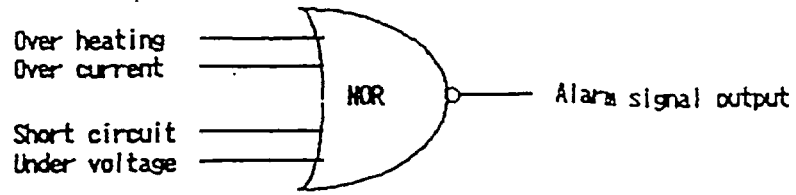

*10 Fig.4 Switching Time Test

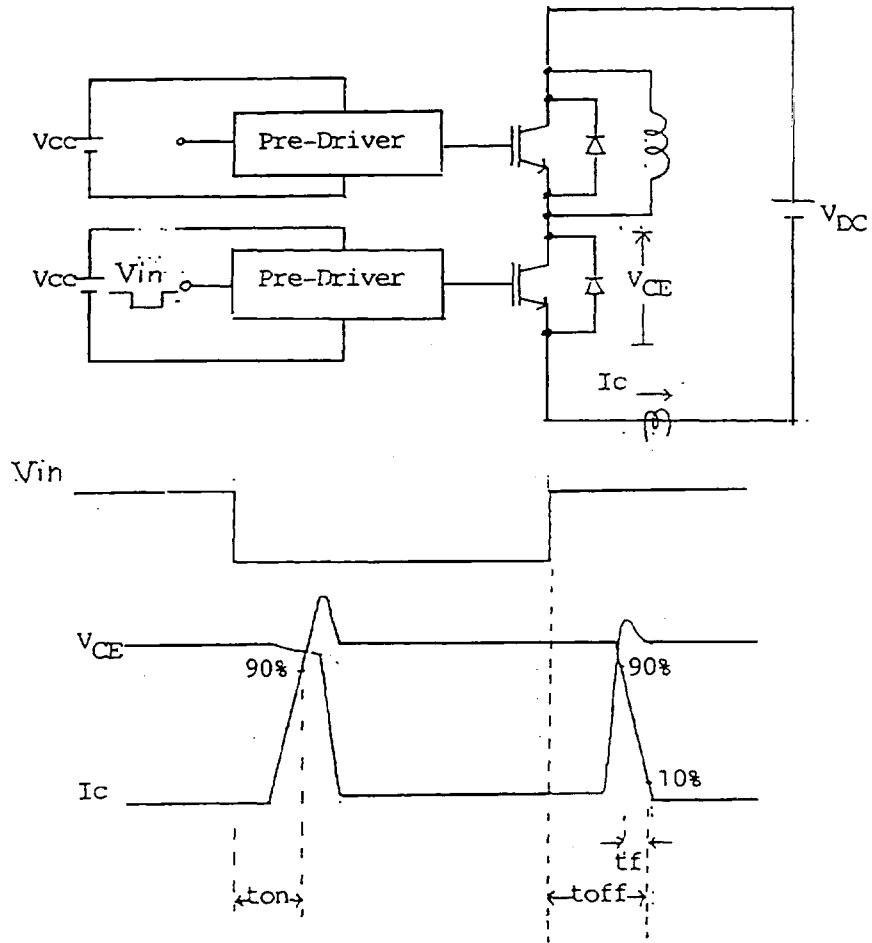

This material and the information herein is the property of Fuji Electric Co., Ltd. They shall be neither reproduced, copied, lent, or disclosed in any way whatsoever for the use of any third party nor used for the manufacturing purposes without the express written consent of Fuji Electric Co., Ltd.

REVISIONS			

	DATE	NAME	APPROVED	Fuji Electric Co., Ltd.	
DRAWN	- -			DWG. NO.	MS6M0065
CHECKED	- -				