

Target Specification of 1MBI300S-120

1. Outline Drawing (Unit : mm)

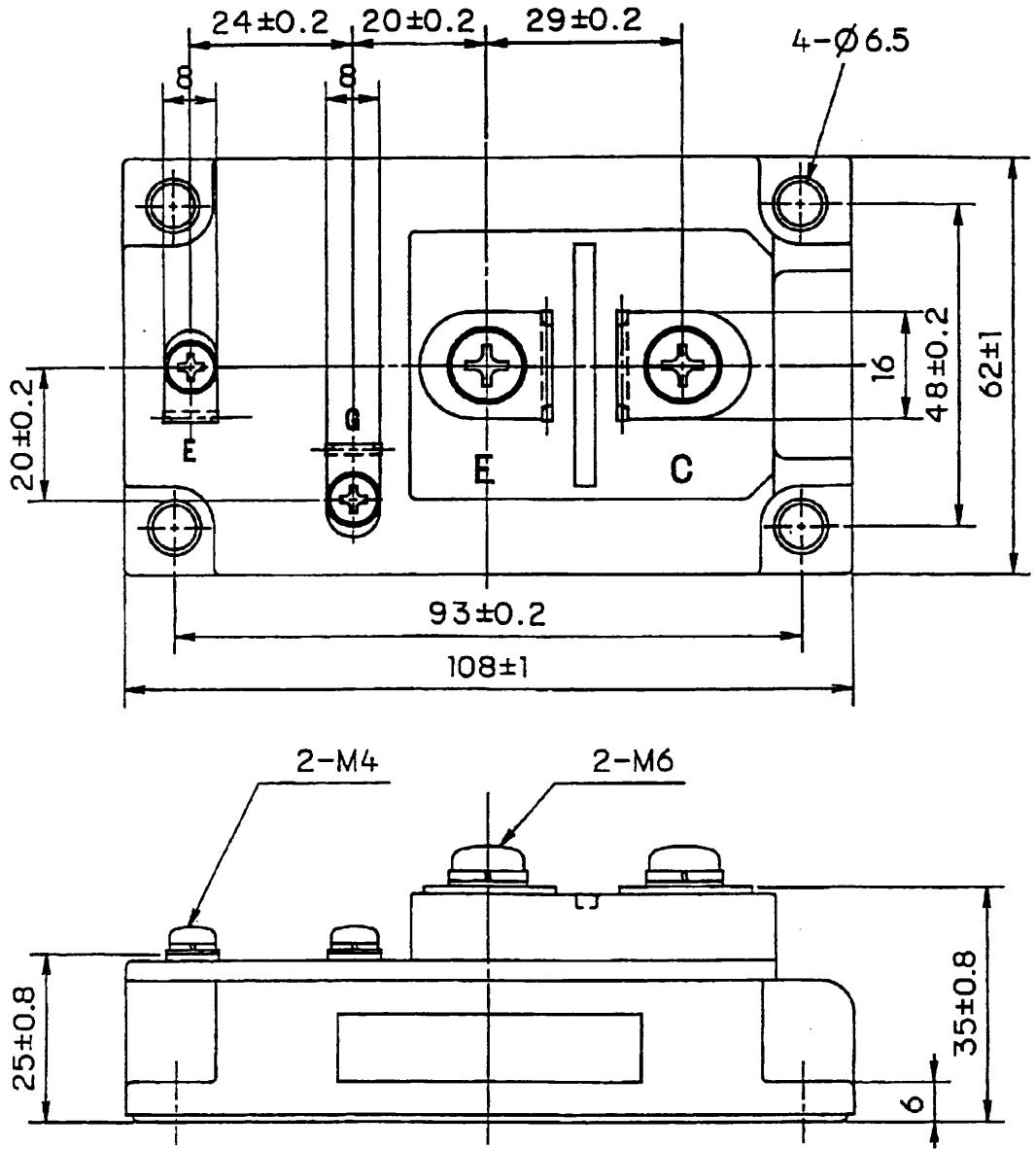

2. Equivalent circuit

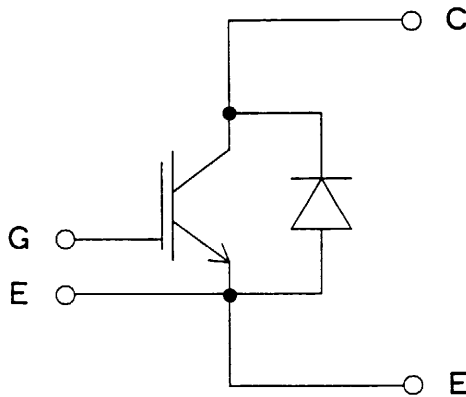

This material and the information herein is the property of Fuji Electric Co. Ltd. They shall be neither reproduced, copied, lent, or disclosed in any way whatsoever for the use of any third party nor used for the manufacturing purposes without the express written consent of Fuji Electric Co., Ltd.

DATE	NAME	APPROVED	Fuji Electric Co., Ltd.
DRAWN Feb -11 -99	N. Arikawa		DWG. NO. MT5F 9782 1/5
CHECKED Feb.-11 -99	S. Miyazaki	T. Miyazaki	
REVISIONS			

3. Absolute Maximum Ratings (at Tc= 25°C unless otherwise specified)

Items	Symbols	Conditions	Maximum Ratings		Units
Collector-Emitter voltage	VCES		1200		V
Gate-Emitter voltage	VGES		±20		V
Collector current	Ic	Continuous	Tc=25°C	400	A
			Tc=80°C	300	
	Ic pulse	1ms	Tc=25°C	800	
			Tc=80°C	600	
			-Ic	300	
-Ic pulse	1ms	600			
Collector Power Dissipation	Pc	1 device	1900		W
Junction temperature	Tj		150		°C
Storage temperature	Tstg		-40~+125		°C
Isolation voltage ^(*1)	Viso	AC : 1min.	2500		V
Screw Torque	Mounting ^(*2)		3.5		N · m
	Terminals ^(*3)		4.5		
	Terminals ^(*4)		1.7		

(*1) All terminals should be connected together when isolation test will be done.

(*2) Recommendable Value : 2.5~3.5 N · m (M5) or (M6)

(*3) Recommendable Value : 3.5~4.5 N · m (M6)

(*4) Recommendable Value : 1.3~1.7 N · m (M4)

4. Electrical characteristics (at Tj= 25°C unless otherwise specified)

Items	Symbols	Conditions	Characteristics			Units
			min.	typ.	Max.	
Zero gate voltage Collector current	ICES	VGE = 0 V, VCE = 1200 V			4.0	mA
Gate-Emitter leakage current	IGES	VCE = 0 V, VGE = ±20 V			0.8	μA
Gate-Emitter threshold voltage	VGE(th)	VCE = 20 V, Ic = 300 mA	5.5	7.2	8.5	V
Collector-Emitter saturation voltage	VCE(sat)	VGE = 15 V Ic = 300 A	Tj = 25 °C	2.3	2.6	V
			Tj = 125 °C	2.8		
Input capacitance	Cies	VGE = 0 V		36000		pF
Output capacitance	Coes	VCE = 10 V		7500		
Reverse transfer capacitance	Cres	f = 1 MHz		6600		
Turn-on time	ton	Vcc = 600 V			1.2	μs
	tr	Ic = 300 A			0.6	
	tr(1)	VGE = ±15 V		0.1		
Turn-off time	toff	RG = 2.7 Ω			1.0	μs
	tf			0.08	0.3	
Forward on voltage	VF	IF = 300 A	Tj = 25 °C	2.5	3.3	V
			Tj = 125 °C	2.1		
Reverse recovery time	trr	IF = 300 A			0.35	μs

5. Thermal resistance characteristics

Items	Symbols	Conditions	Characteristics			Units
			min.	typ.	Max.	
Thermal resistance (1 device)	Rth(j-c)	IGBT			0.066	°C/W
		FWD			0.220	
Contact Thermal resistance	Rth(c-f)	with Thermal Compound ^(*)		0.0125		

* This is the value which is defined mounting on the additional cooling fin with thermal compound.

Note :

- This specification is only for technical considerations, and not for contract.
- This specification is subject to be changed without notices.

This material and the information herein is the property of Fuji Electric Co. Ltd. They shall be neither reproduced, copied, lent, or disclosed in any way whatsoever for the use of any third party nor used for the manufacturing purposes without the express written consent of Fuji Electric Co., Ltd.

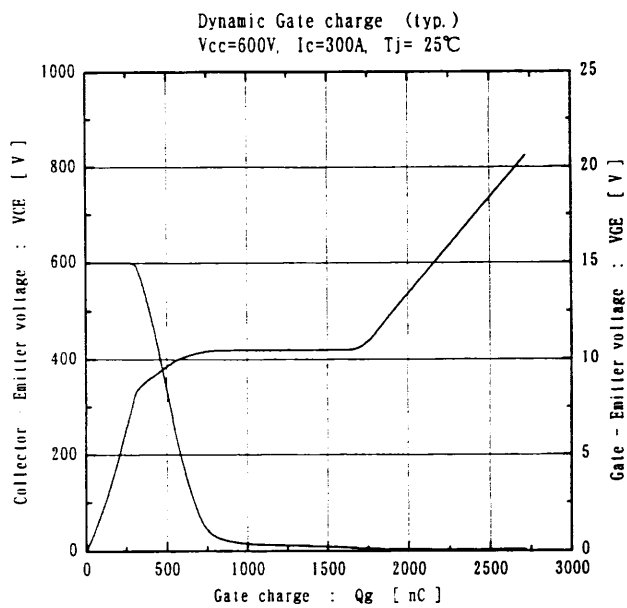
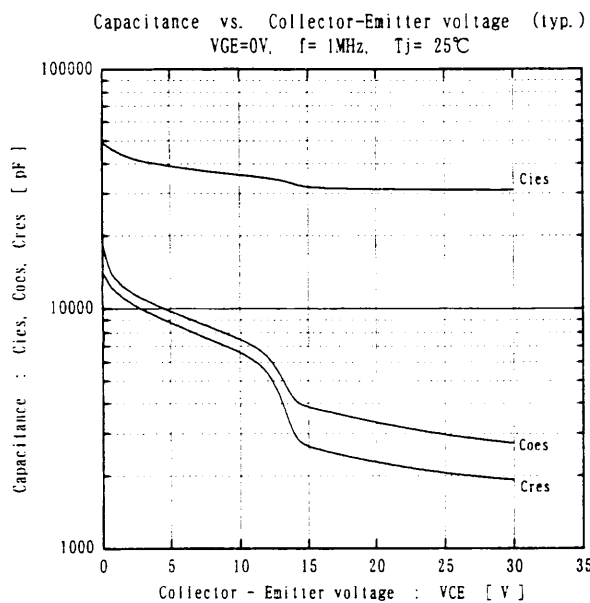
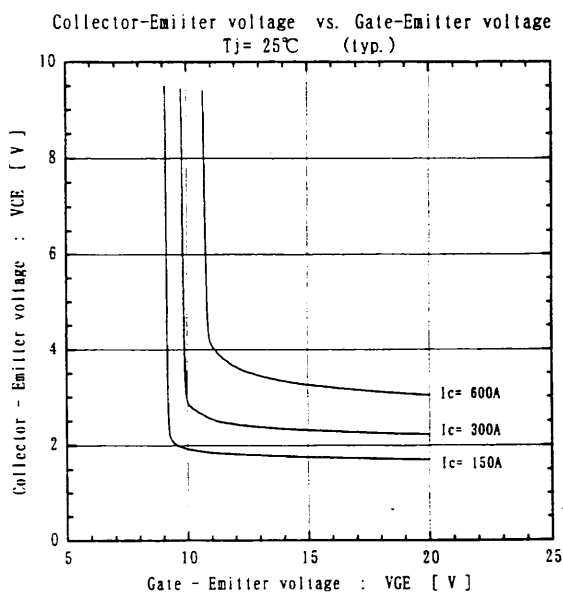
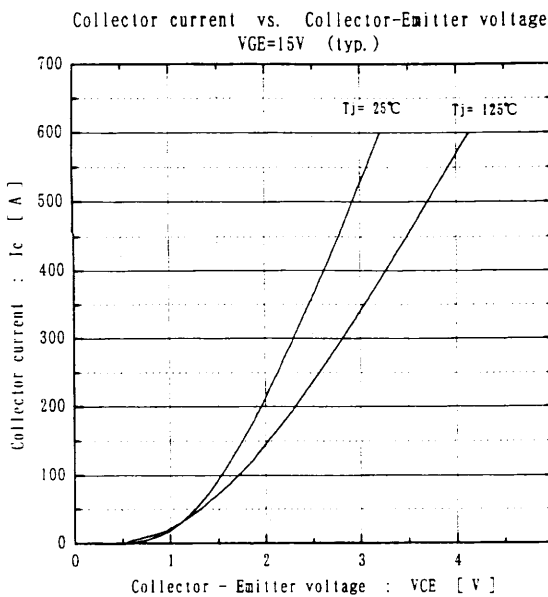
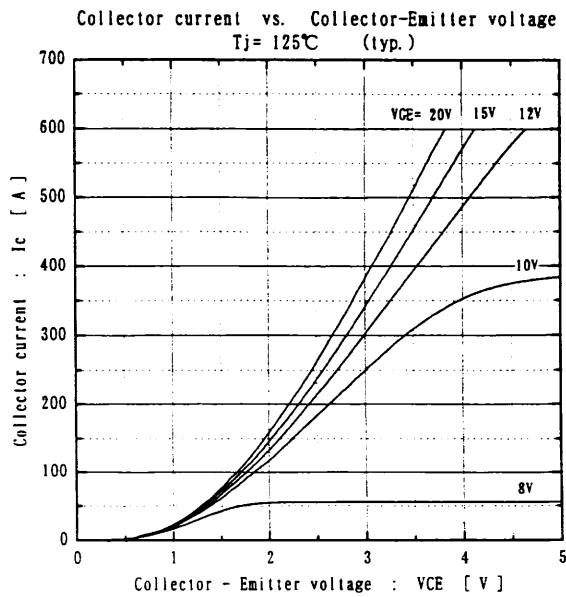
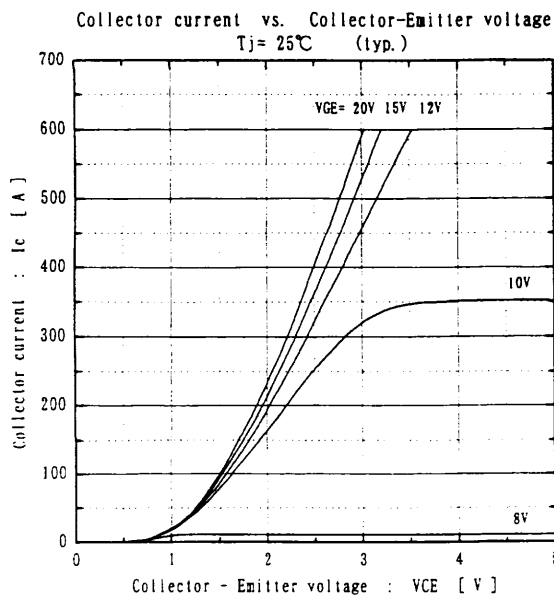

Fuji Electric Co., Ltd.

DWG. NO.

MT 5 F 9 7 8 2

3/5

REVISIONS

This material and the information herein is the property of Fuji Electric Co., Ltd. They shall be neither reproduced, copied, lent, or disclosed in any way whatsoever for the use of any third party nor used for the manufacturing purposes without the express written consent of Fuji Electric Co., Ltd.

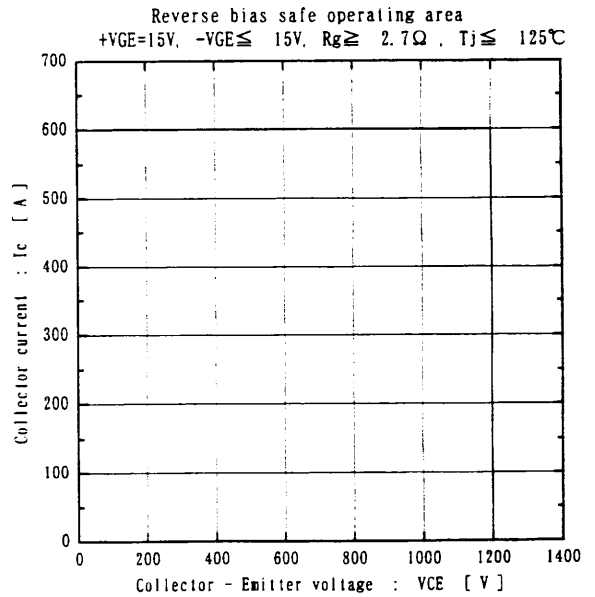
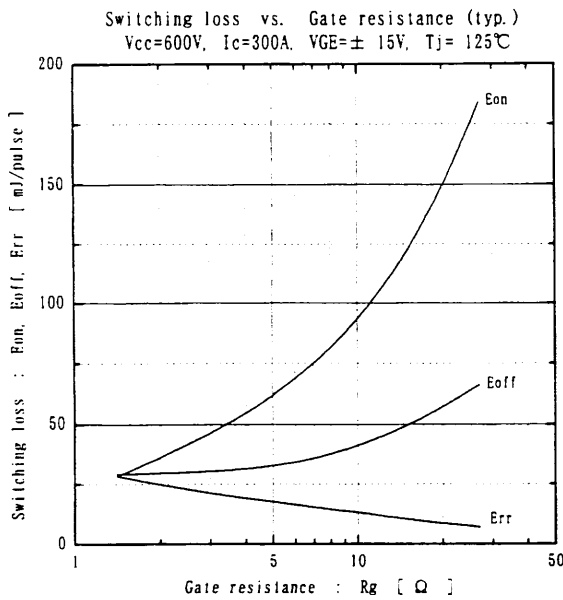
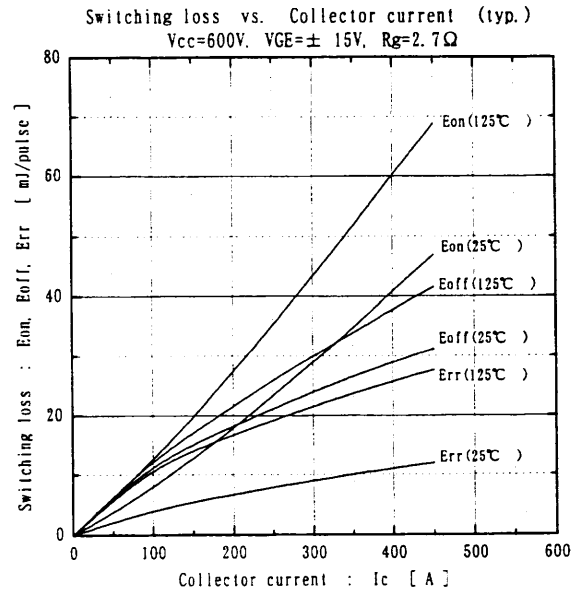
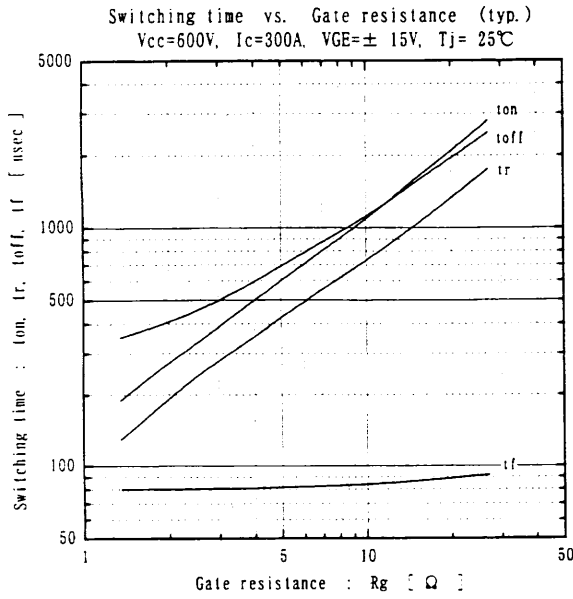
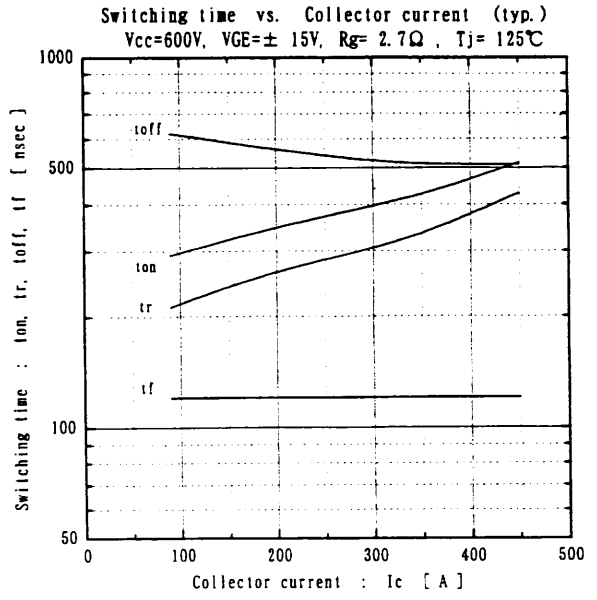
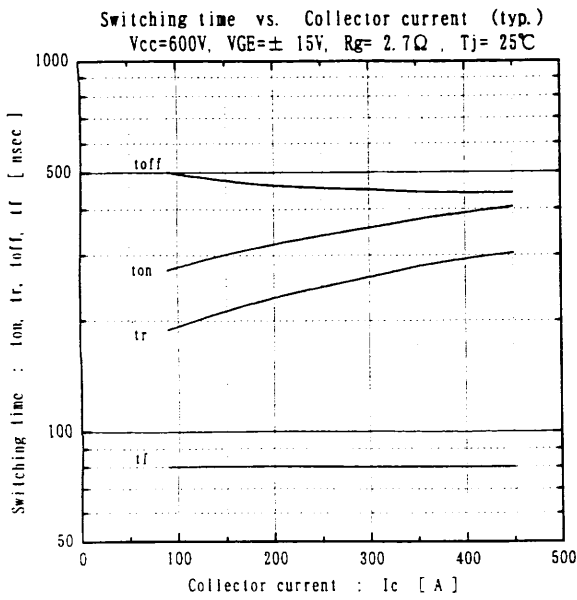

This material and the information herein is the property of Fuji Electric Co. Ltd. They shall be neither reproduced, copied, lent, or disclosed in any way whatsoever for the use of any third party nor used for the manufacturing purposes without the express written consent of Fuji Electric Co., Ltd.

Forward current vs. Forward on voltage (typ.)

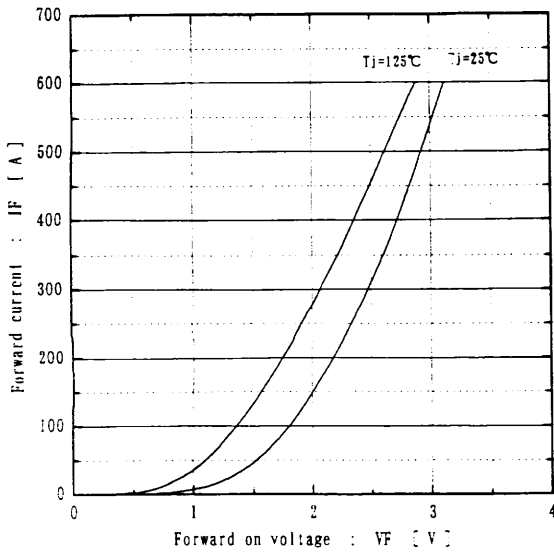

Reverse recovery characteristics (typ.)
Vcc=600V, VGE=±15V, Rg=2.7Ω

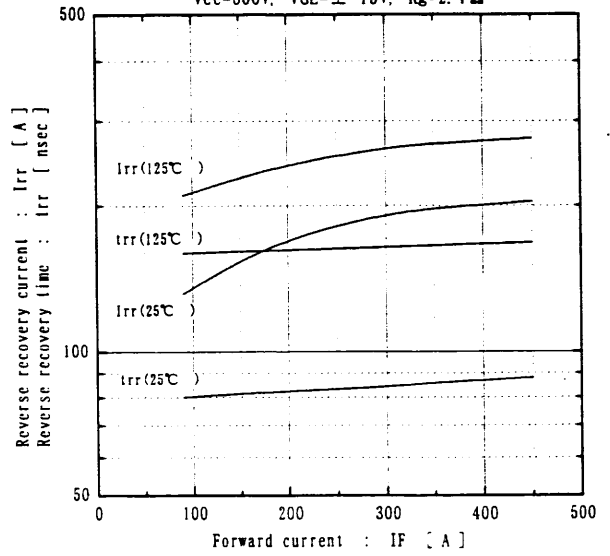

Transient thermal resistance

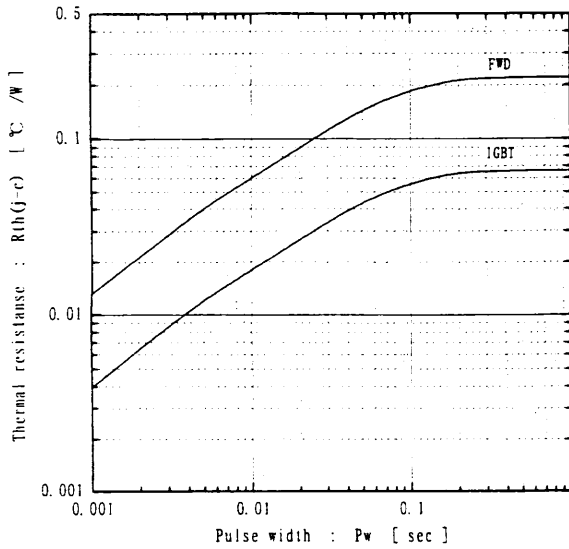

Definitions of switching time

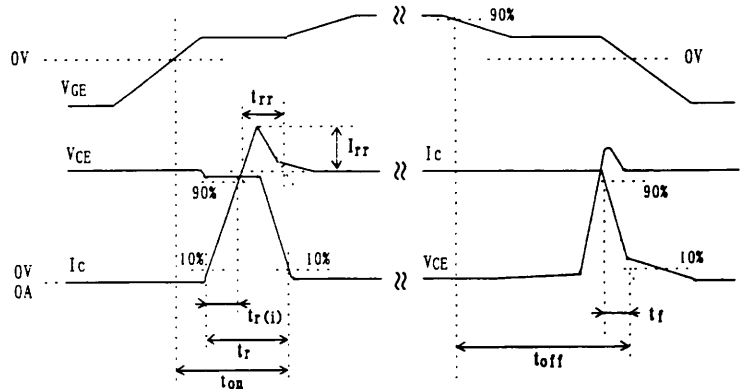
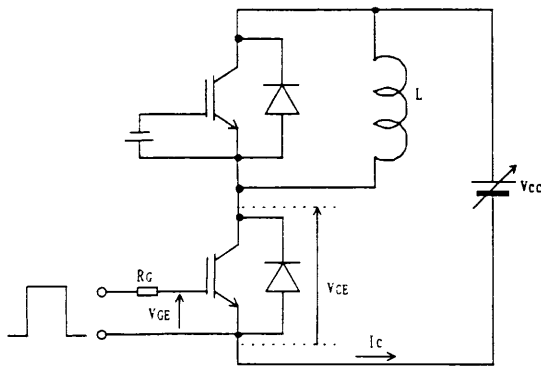

This material and the information herein is the property of Fuji Electric Co. Ltd. They shall be neither reproduced, copied, lent, or disclosed in any way whatsoever for the use of any third party nor used for the manufacturing purposes without the express written consent of Fuji Electric Co., Ltd.

REVISIONS

Fuji Electric Co., Ltd.

DWG. NO. MT5F 9782

5/5